

# USER MANUAL

**Glas** **Craft**  
DISPENSING EXCELLENCE

## MHII *Dispensing System*



**Glas** **Craft**  
DISPENSING EXCELLENCE

5845 WEST 82ND STREET  
INDIANAPOLIS, INDIANA  
46278 U.S.A.

Phone (317) 875-5592

Fax (317) 875-5456

Email [gcisales@glascraft.com](mailto:gcisales@glascraft.com)

Web [www.glascraft.com](http://www.glascraft.com)

CE  
CERTIFIED



# Table Of Contents

## Introduction

About This Manual.....	1
------------------------	---

## Parts & Illustrations

MH II System List / Options / Repair Parts Kits .....	2
System Specifications .....	3
22850-XX MH II System Console .....	4
22850-XX MH II System Assembly .....	6
22852-XX MH II Control Box Assembly .....	15
22852-XX MH II Schematic .....	20
22852-01 MH II Schematic .....	22
21835-00 Fluid Section Assembly .....	25
22075-00 Heat Exchanger Assembly .....	27
19524-01 Medium Pressure Hose Assembly .....	31
Typical System Layout .....	32
Typical System Hose Connections For 50 Ft. ....	33
Typical System Connections For 100-300 Ft. ....	34

## Safety

Urethane Safe Handling and Use of Foam Equipment .....	35
--	----

## Installation

Instructions .....	39
Optional Transfer Pump Installation / Air Dryer Kit .....	41
Electrical Connections .....	42
Hydraulic Pack .....	42

## Operation

Initial Start-up Procedures .....	43
Over Pressure System Protection .....	46
Over Pressure Problem Correction .....	47
System Shut Down .....	48
System Daily Start-Up .....	49

Limited Warranty Policy .....	51
-------------------------------	----

Notes .....	52
-------------	----

If You Have An Equipment Problem .....	56
--	----

For Your Reference .....	INSIDE BACK COVER
--------------------------	-------------------

# Introduction

## About This Manual

Before operating, maintaining or servicing any **GlasCraft** system, read and understand all of the technical and safety literature provided with **GlasCraft** products. If you do not have the proper or related manuals and safety literature for your **GlasCraft** system, contact your GlasCraft distributor or **GlasCraft, Inc.**

In this **GlasCraft** technical and safety publication, the following advisories will be provided where appropriate:

### NOTE

*Is information about the procedure in progress.*

### CAUTION

*Is imperative information about equipment protection.*

### WARNING

*Is imperative information about personal safety.*

The information in this document is intended only to indicate the components and their normal working relationship typical use. Each assembly should be directed by a **GlasCraft** distributor or made from the **GlasCraft** assembly instructions provided.

This manual provides information for the assembly, operation, maintenance and service of this **GlasCraft** product as used in a typical configuration. While it lists standard specifications and procedures, some deviations may be found.

In order to provide our users with the most up-to-date technology possible, we are constantly seeking to improve products. If technological change occurs after a product is on the market, we will implement that technology in future production and, if practical, make it available to current users as a retrofit, up-date or supplement. If you find some discrepancy between your unit and the available documentation, contact your **GlasCraft** distributor to resolve the difference. **GlasCraft, Inc.** reserves the right to change or modify this product as it deems necessary.

Careful study and continued use of this manual will provide a better understanding of the equipment and process, resulting in more efficient operation, longer trouble-free service and faster, easier troubleshooting.

# Parts & Illustrations

## MH II Dispensing System

25lbs.(12kg.)/min. Spray or Pour Dispensing System

---

### Includes

22850-XX	MH II Dispensing System
17254-XX	Probler Gun Assembly • W/ Round Spray Mixing Chamber
18006-01	Whip Hose Assembly
19524-01	Medium Pressure Heated Hose Assembly
17661-XX	Gun Service Kit
59934-04	Diocetyl Phthalate, 1 Qt.
GC-1267	System User Manual

---

### Options

22023-01	High Pressure Hose Assy., 50 Ft.
19524-01	Medium Pressure Hose Assy., 50 Ft.
22094-00	Required To Complete Hose Electrical Circuit when used with 18006-00 whip hose.

---

### Recommended Service Kits

17661-XX	Gun Service Kit
21063-00	Heat Exchanger Kit
21845-00	Pump Fluid Section Repair Kit

# System Specifications

Material Ratio:	1:1 (Fixed)
Material Viscosity:	200- 2000 Centipoise (Cps) At Operating Temperatures
Output:	.021 GPS .042 GPC
Operating Temperatures:	32° F ( 0° C ) - 190° (88 ° C )
Operating Psi:	3000 Psi. Max (Over Psi Switches Set)
Hoses:	2200 PSI. W/ 19524-01 2600 PSI. W/ 22024-01
Hydraulic Psi To Pumps:	2:1 Ratio 1000 PSI. Hydraulic PSI. 2000 PSI. Fluid PSI. Per Side.
Purging:	Automatic Pneumatic, Solvent-free, Constant
Electrical Requirements:	74 Amps @ 208/240 Vac, 50/60 Hz Single Phase 5 HP 35 Amps @ 208/240 Vac, 50/60 Hz Three Phase 5 HP 27 Amps @ 380 Vac, 50 Hz Three Phase 5 HP
Compressed Air Requirements:	15 Cfm @ 100 Psi 425 Liters @ 6.8 Bar
Max Hose Length:	310' X 3/8 I.d. Hose Includes 10' X 1/4 I.d. Heated Whip Hose
Shipping Weight:	950 Lbs
Overall Dimensions:	

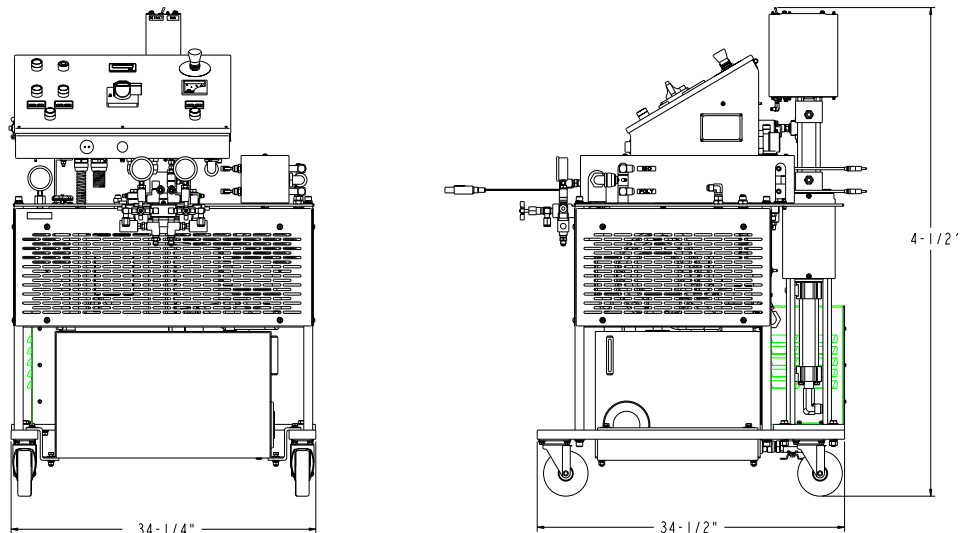

22850-XX MH System Console

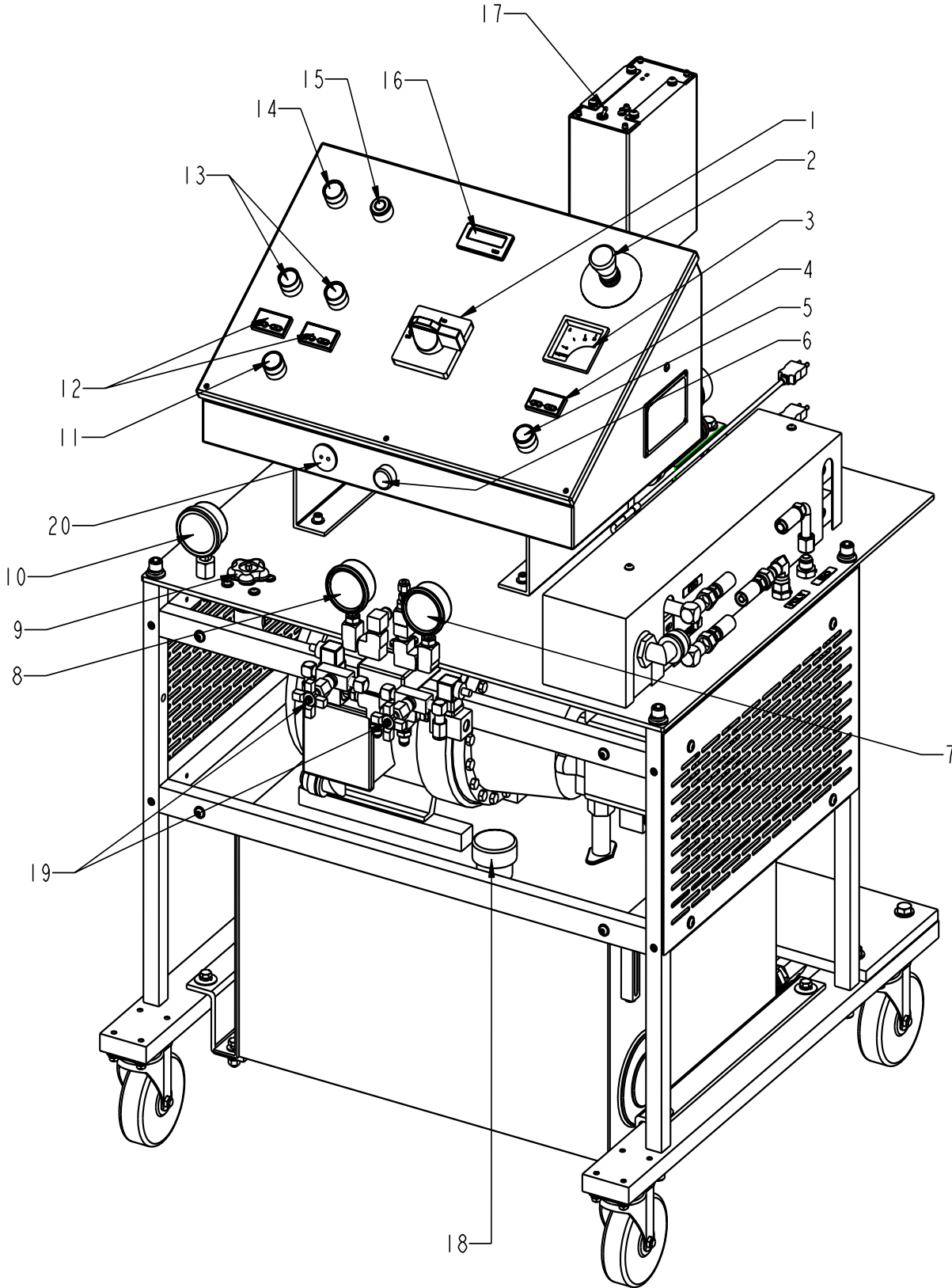

## 22850-XX MH System Console

1	MAIN POWER SWITCH	Controls power and door; handle must point 1 to energize power , handle must point to 0 to open control box door. White pilot indicates when lighted, that the main power is on.
2	EMERGENCY STOP PUSH BUTTON	To stop all functions, push down on red button. To reset, turn handle on push button. All functions will remain off until main power switch has been switched off and back on
3	AMMETER	An instrument for measuring amperes to the primary side of the hose's transformer.
4	HOSE TEMPERATURE CONTROLLER	Controls temperature of liquid inside the heated hoses. To set desired temperature, press the up or down button until you reach desired temperature From this point, the temperature control is completely automatic.
5	ON PUSH BUTTON	Powers the controller. It requires 10 seconds for the Controller to respond.
6	WHITE PILOT LIGHT	Indicates power on.
7	POLY PRESSURE GAUGE	Indicates material pressure.
8	ISO PRESSURE GAUGE	Indicates material pressure.
9	HYDRAULIC PRESSURE KNOB	Increases or decreases hydraulic pressure. Turn clockwise to increase pressure. Turn counter-clockwise to decrease pressure.
10	HYDRAULIC PRESSURE GAUGE	Indicates hydraulic pump pressure
11	ON PUSH BUTTON	Powers the controller. It requires 10 seconds for the Controller to respond.
12	ISO / POLY TEMPERATURE CONTROLLER	Controls temperature of liquid inside ISO heater. To set desired temperature, press the up or down button until you reach desired temperature. From this point, the temperature control is completely automatic.
13	OVER-PRESSURE RESET BUTTONS	When over-pressure is detected, the hydraulic power pack will be shut down, and will remain off until pressure is reduced and the push button is reset.
14	ON PUSH BUTTON	Power On To the hydraulic power pack.
15	OFF PUSH BUTTON	Power Off to the hydraulic power pack.
16	COUNTER	Counts pumps cycles. .042 GPC / .021 GPS
17	RETRACT SWITCH	Retracts pumps to the full down stroke position to protect pump shafts.
18	HYDRAULIC OIL FILL CAP	Remove cap to fill tank with <i>recommended</i> hydraulic oil.
19	ISO / POLY DUMP VALVES	Relieves pressure and material from ISO & POLY side.
20	HOSE THERMOCOUPLE OUTLET	Power outlet for hose thermocouple.

# 22850-XX MH II System Assembly

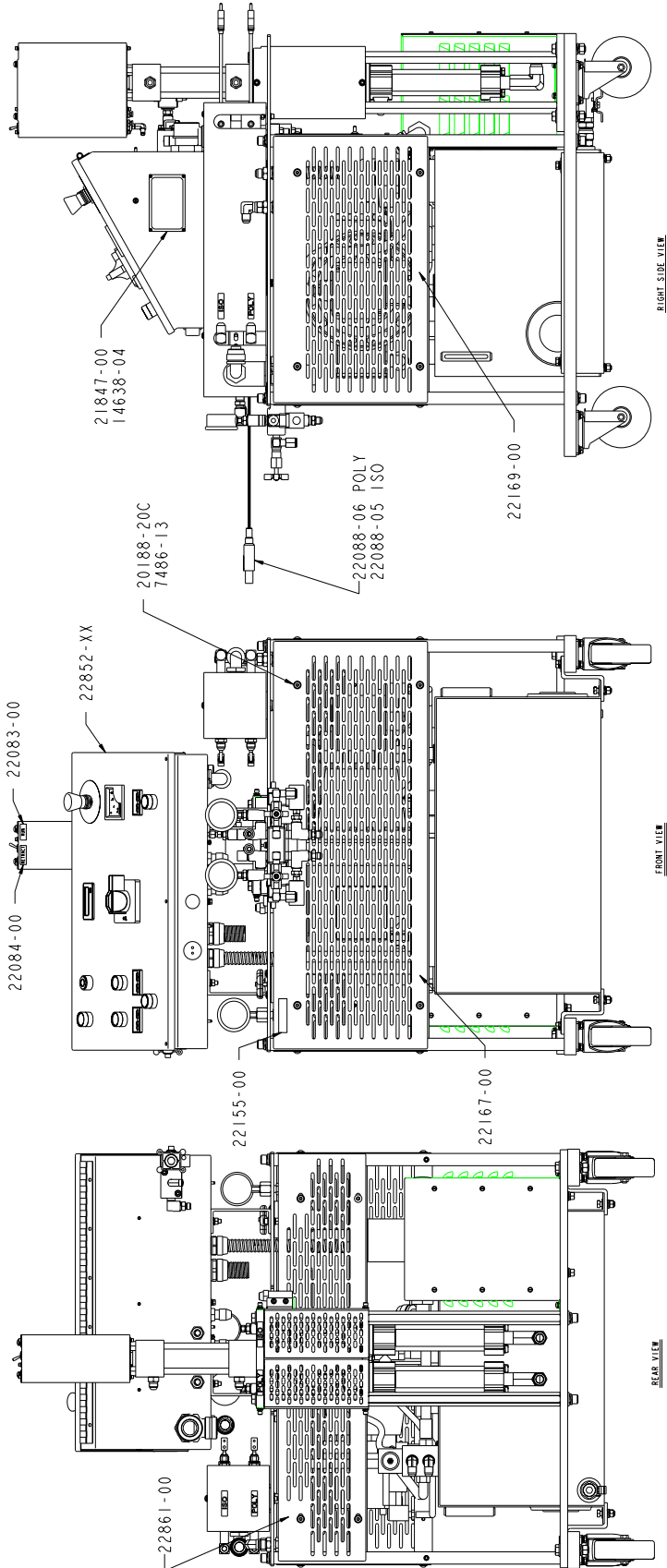

REVISION P

# 22850-XX MH II System Assembly

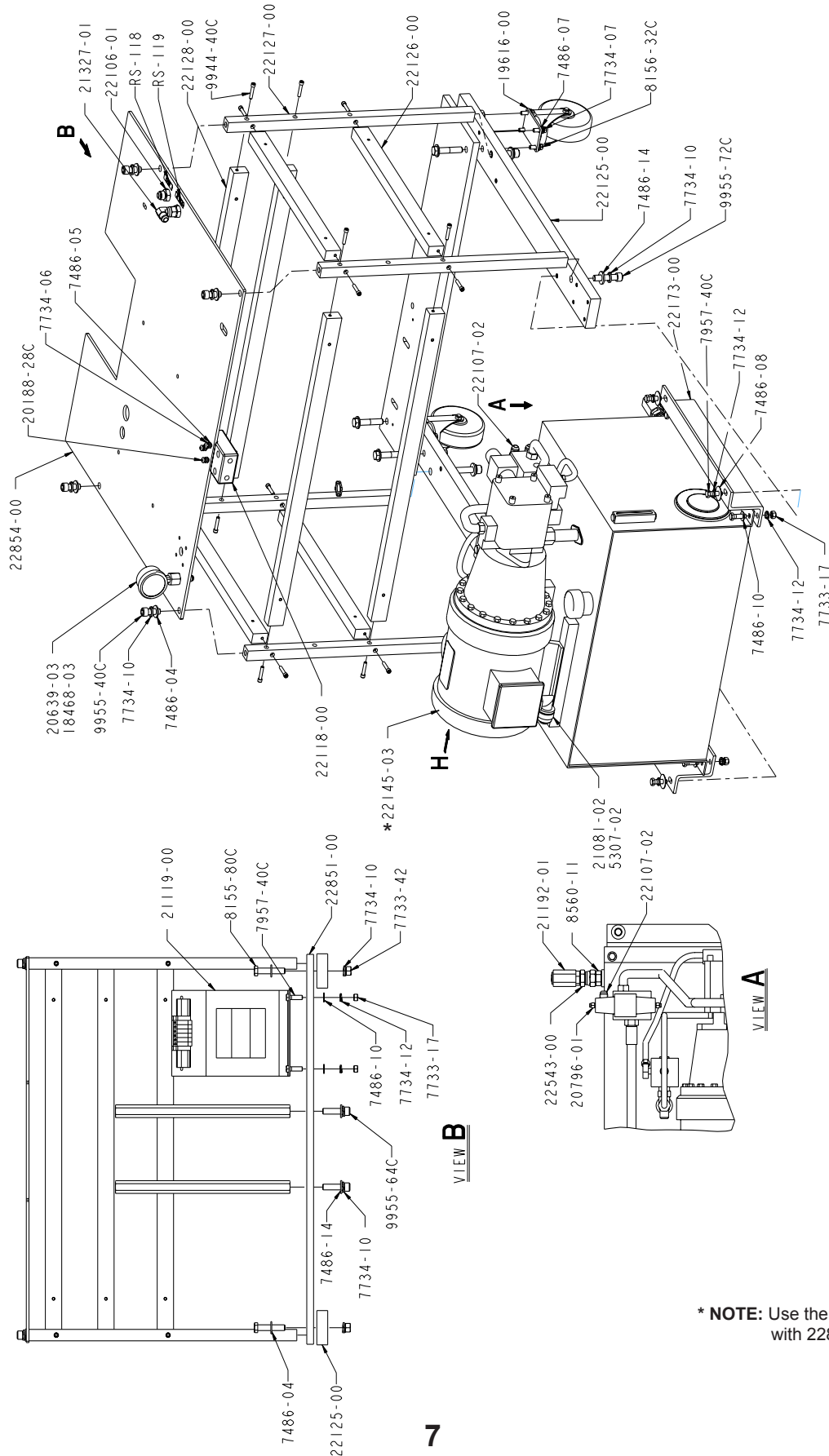

\* NOTE: Use the 22145-05 power pack with 22850-01.

**REVISION P**

# 22850-XX MH II System Assembly

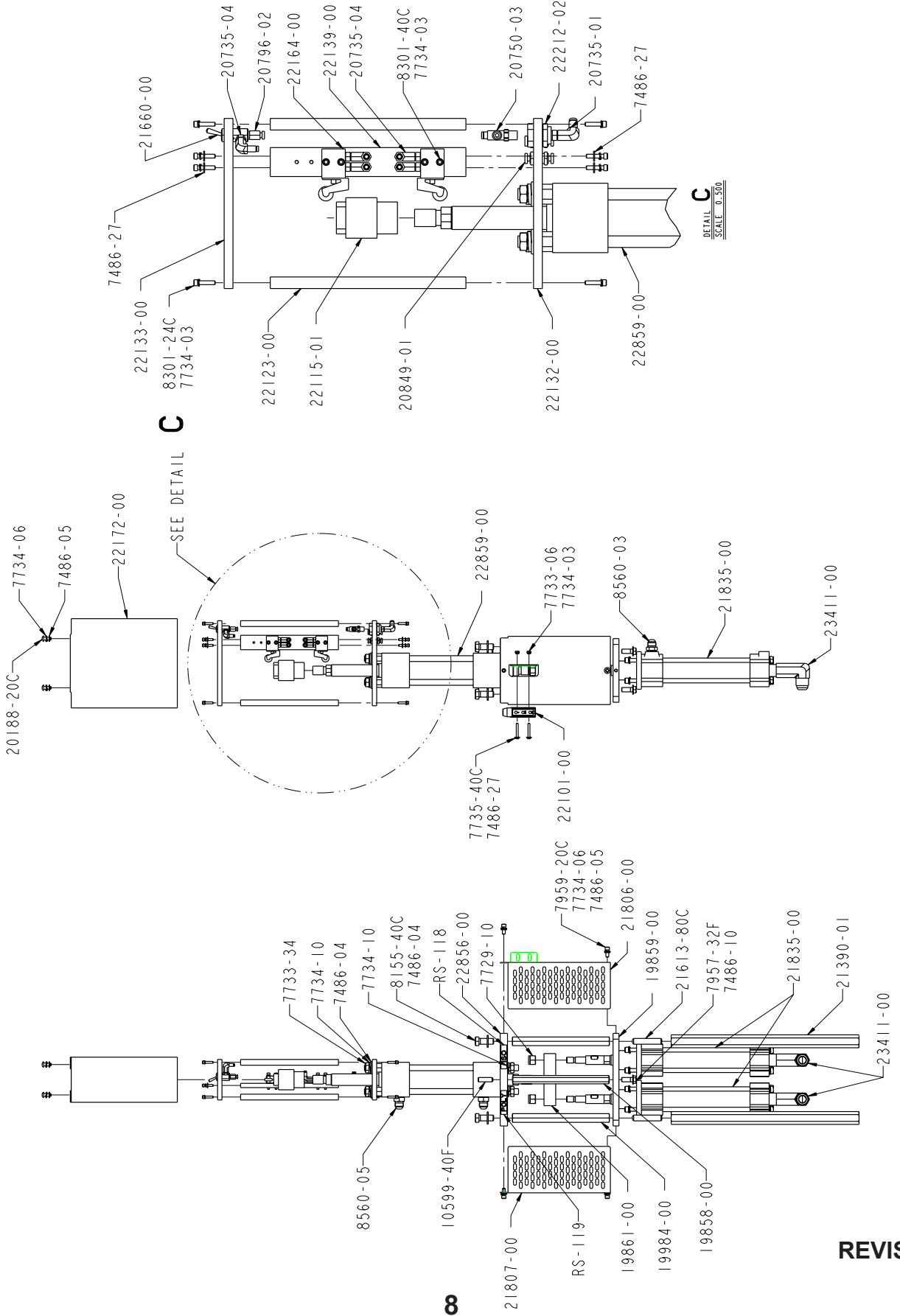

**C**

**C**  
DETAIL  
SCALE 0.500

SEE DETAIL

# 22850-XX MH II System Assembly

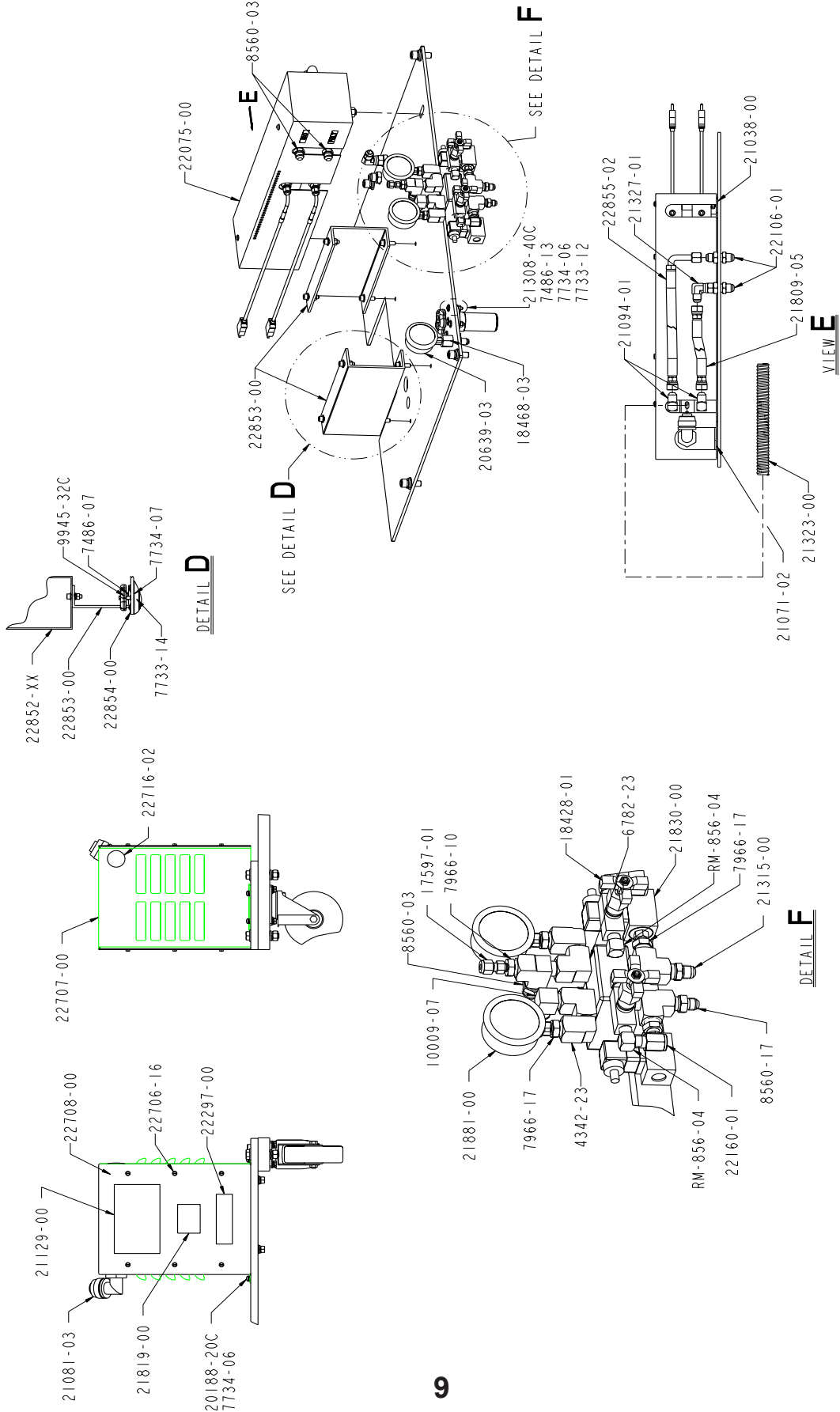

# 22850-XX MH II System Assembly

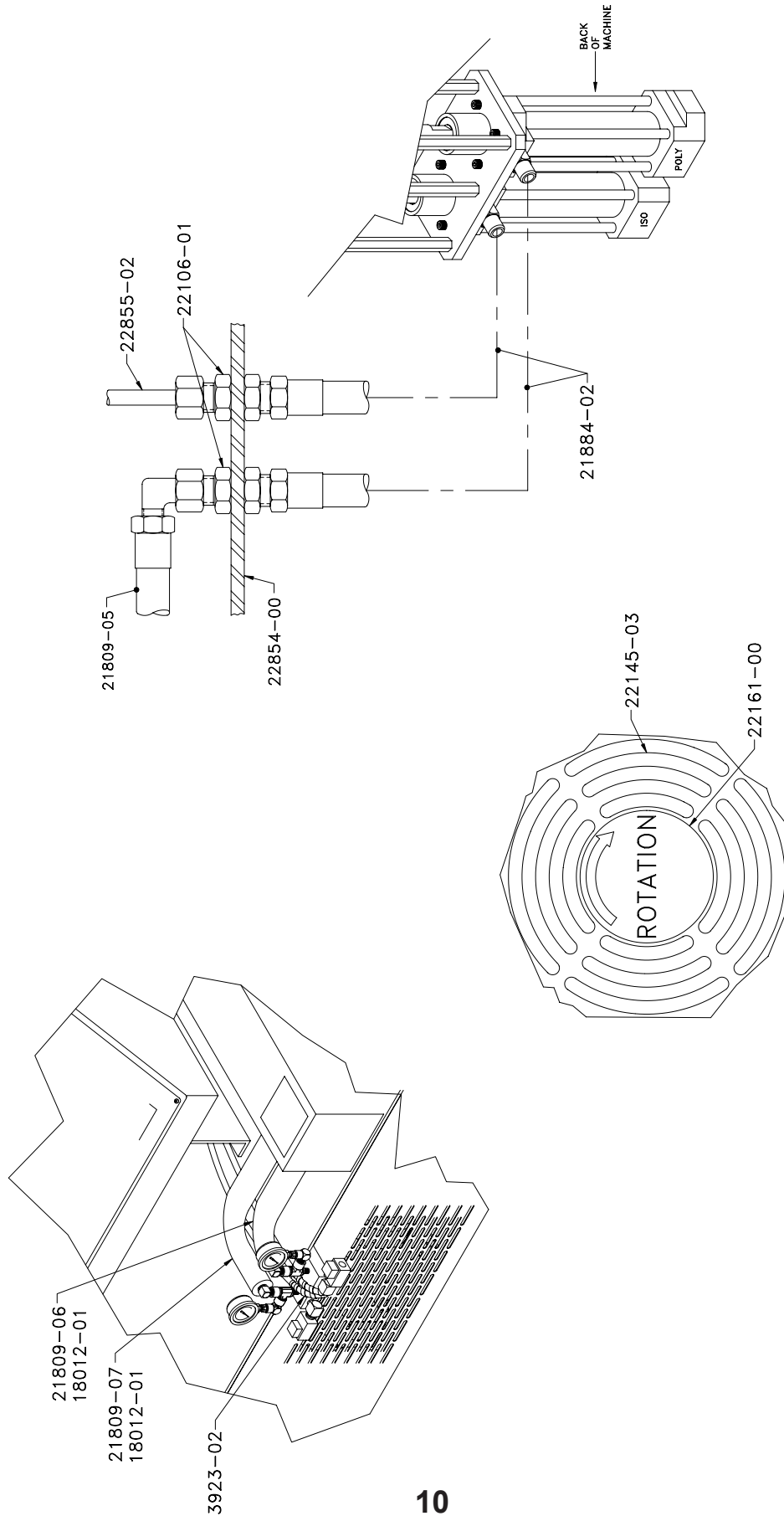

DETAIL H

REVISION P

# 22850-XX MH II System Assembly

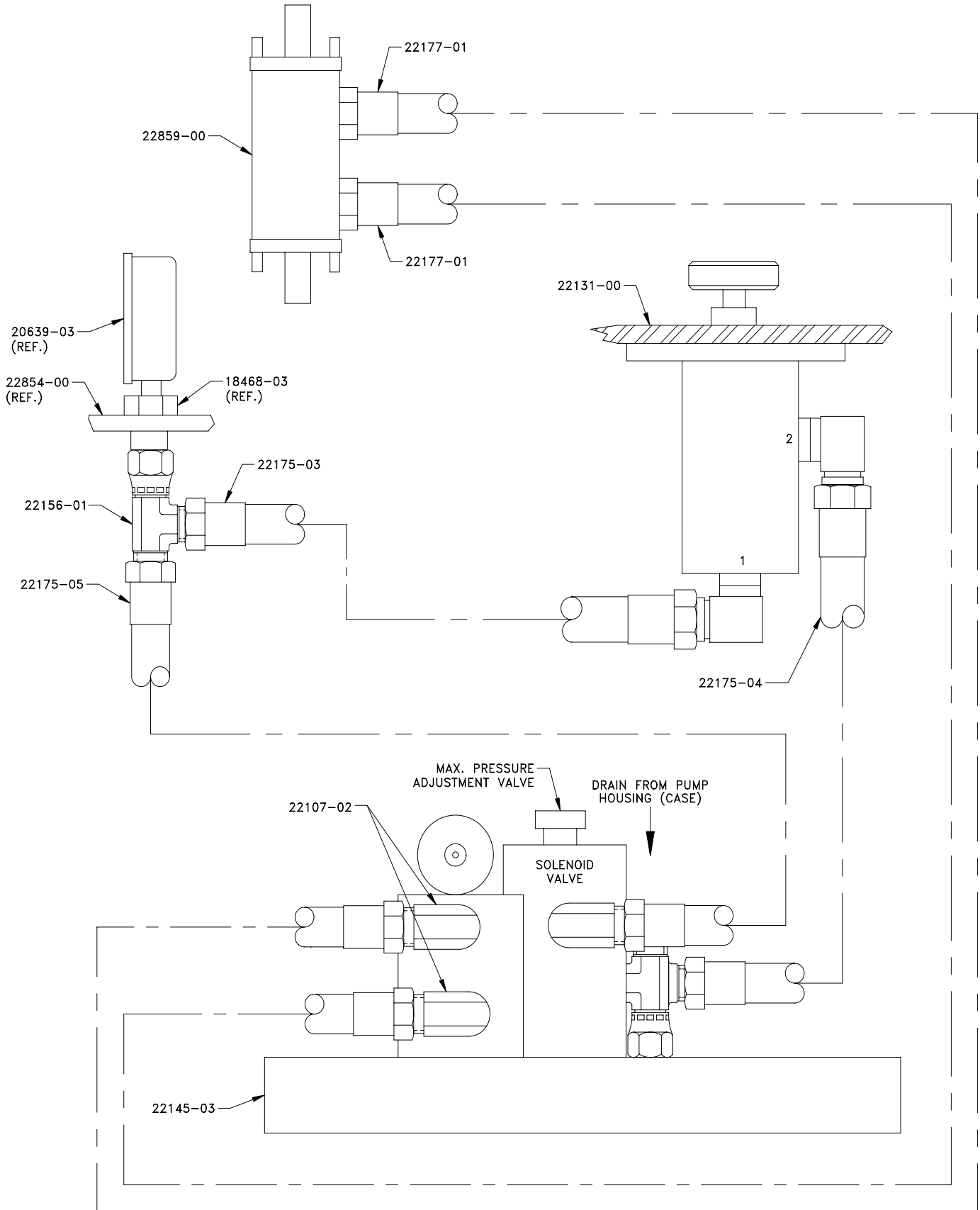

# 22850-XX MH II System Assembly

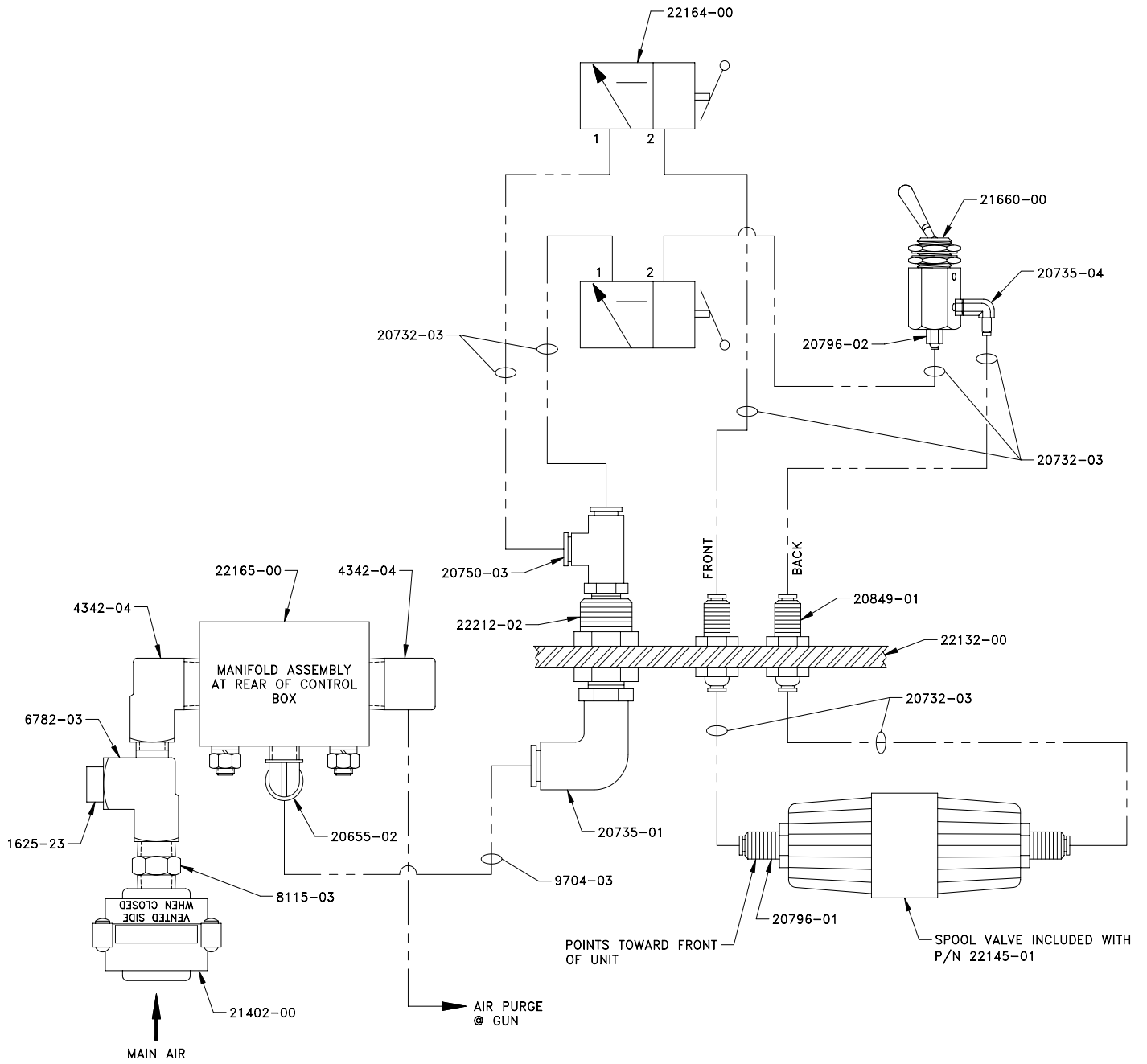

**REVISION P**

## 22850-XX MH II System Assembly Parts List

PART NUMBER	DESCRIPTION
RM-856-04	ELBOW FITTING
RS-118	ISO DECAL
RS-119	POLY DECAL
10009-04	ELBOW FITTING
10009-06	ELBOW FITTING
10009-07	ELBOW FITTING
10599-40F	SET SCREW
13424-03	CABLE TIE
14638-04	RIVET
17597-01	CONNECTOR FITTING
18012-01	HEATED HOSE COVER
18428-01	NEEDLE VALVE
18468-03	FITTING
19507-04	AIR HOSE ASSEMBLY
19616-00	SWIVEL CASTER
19858-00	AIR MOTOR STAND-OFF
19859-00	PUMP MOUNTING PLATE
19861-00	PUMP SADDLE
19984-00	AIR MOTOR STAND-OFF
20188-20C	SCREW
20188-28C	SCREW
20639-03	GAUGE
20732-03	TUBING
20735-01	ELBOW FITTING
20735-04	ELBOW FITTING
20750-03	SWIVEL TEE FITTING
20796-01	FITTING
20796-02	FITTING
20849-01	UNION BULKHEAD FITTING
21094-01	ELBOW FITTING
21119-00	TRANSFORMER
21129-00	TRANSFORMER DECAL
21308-40C	MACHINE SCREW
21315-00	CONNECTOR FITTING
21323-00	FLEXIBLE CONDUIT
21327-01	ELBOW FITTING
21390-01	AIR MOTOR STAND-OFF
21613-80C	SET SCREW
21660-00	2-WAY CONTROL VALVE
21806-00	LEFT GUARD
21807-00	RIGHT GUARD
21809-05	MATERIAL HOSE
21809-06	MATERIAL HOSE
21809-07	MATERIAL HOSE

PART NUMBER	DESCRIPTION
21819-00	LIVE WIRE DECAL
21835-00	PUMP ASSEMBLY
21847-00	CE PLATE
21881-00	PRESSURE GAUGE
21884-02	MATERIAL HOSE
22074-00	THERMOCOUPLE ASSEMBLY
22075-00	HEAT EXCHANGER ASSEMBLY
22083-00	RUN DECAL
22084-00	RETRACT DECAL
22088-05	ISO ELECTRIC PLUG ASSEMBLY
22088-06	POLY ELECTRIC PLUG ASSEMBLY
22105-00	(ISO) HEAT EXCHANGER ASSEMBLY
22101-00	ROLLER LIMIT SWITCH
22106-01	BULKHEAD FITTING
22107-02	ELBOW FITTING
22110-00	(POLY) HEAT EXCHANGER ASSEMBLY
22115-01	UPPER SHAFT CAM ADAPTER
22118-00	ISOLATION HOSE MOUNTING BLOCK
22123-00	CHANGEOVER STAND-OFF
22124-00	BOTTOM PUMP BRACKET
22125-00	MOUNTING PLATE
22126-00	SIDE FRAME SUPPORT
22127-00	VERTICAL FRAME SUPPORT
22128-00	FRONT FRAME SUPPORT
22132-00	BOTTOM CHANGEOVER PLATE
22133-00	TOP CHANGEOVER PLATE
22139-00	LIMIT SWITCH MOUNTING BRACKET
22145-03	HYDRAULIC MOTOR
22155-00	DECAL HYDRAULIC PRESSURE
22156-01	TEE FITTING
22160-01	CAP
22161-00	ROTATION DECAL
22164-00	DIRECTIONAL CONTROL VALVE
22167-00	FRONT HYDRAULIC MOTOR COVER
22169-00	SIDE HYDRAULIC MOTOR COVER
22172-00	COUNTER CHANGEOVER GUARD
22173-00	HYDRAULIC PUMP SUPPORT BRACKET
22175-03	MATERIAL HOSE
22175-04	MATERIAL HOSE
22175-05	MATERIAL HOSE
22177-01	MATERIAL HOSE
22212-02	BULKHEAD FITTING
22297-00	CONNECTION NOTICE DECAL
22543-00	SWIVEL FITTING

## 22850-XX MH II System Assembly Parts List

PART NUMBER	DESCRIPTION
22706-16	SCREW
22707-00	TRANSFORMER COVER
22716-02	HOLE PLUG
22851-00	BOTTOM BRACKET
22852-XX	CONTROL BOX ASSEMBLY
22853-00	CONTROL BOX SUPPORT
22854-00	MOUNTING PLATE
22855-02	MATERIAL HOSE
22856-00	MOUNTING PLATE
22859-00	HYDRAULIC CYLINDER
22861-00	REAR GUARD
23411-00	ELBOW FITTING
3795-00	TERMINAL RING LUG
3923-02	SPIRAL WRAP
4342-23	TEE PIPE FITTING
5307-02	CONDUIT NUT
6782-23	TEE FITTING
7208-02	WIRE NUT
7208-04	WIRE NUT
7486-04	FLAT WASHER
7486-05	FLAT WASHER
7486-07	FLAT WASHER
7486-08	FLAT WASHER
7486-10	LOCK WASHER
7486-13	FLAT WASHER
7486-14	FLAT WASHER
7486-27	FLAT WASHER
7729-10	NUT
7733-06	NUT
7733-12	NUT
7733-14	NUT
7733-17	NUT
7733-34	NUT
7733-42	NUT
7734-03	LOCK WASHER
7734-06	LOCK WASHER
7734-07	LOCK WASHER
7734-10	LOCK WASHER
7734-12	LOCK WASHER
7735-40C	SCREW
7957-40C	SCREW
7958-32C	SCREW
7957-32F	SCREW
7957-40F	SCREW
7959-20C	SCREW

PART NUMBER	DESCRIPTION
7966-10	PIPE FITTING
7966-17	PIPE FITTING
8155-40C	SCREW
8155-80C	SCREW
8156-32C	SCREW
8301-24C	SCREW
8301-40C	SCREW
8560-03	CONNECTOR FITTING
8560-05	CONNECTOR FITTING
8560-11	CONNECTOR FITTING
8560-17	CONNECTOR FITTING
8846-03	COPPER WIRE
9704-03	TUBING
9944-40C	SCREW
9945-32C	SCREW
9955-40C	SCREW
9955-64C	SCREW
9955-72C	SCREW

# 22852-XX MH II Control Box Assembly

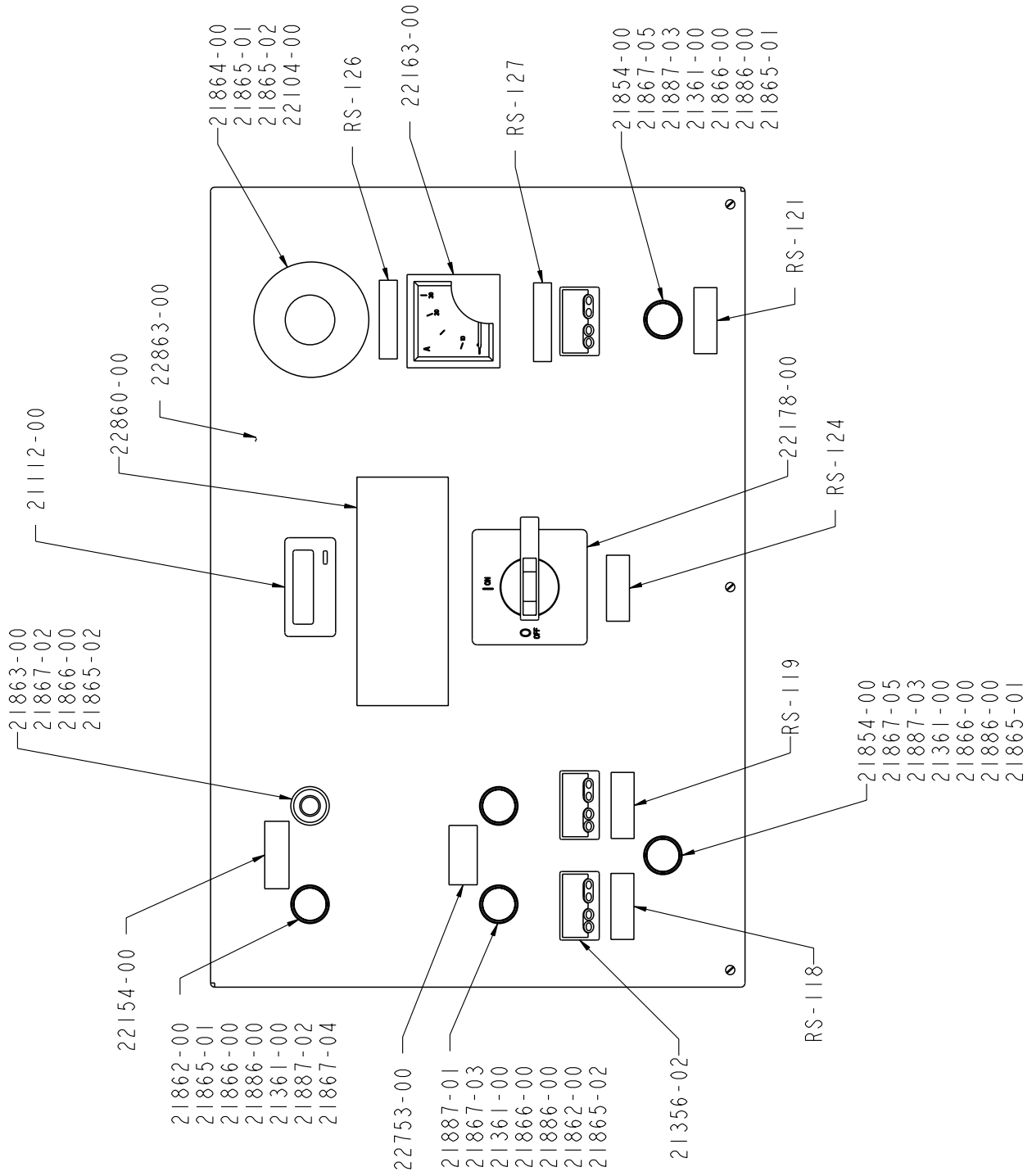

SECTION A-A

# 22852-XX MH II Control Box Assembly

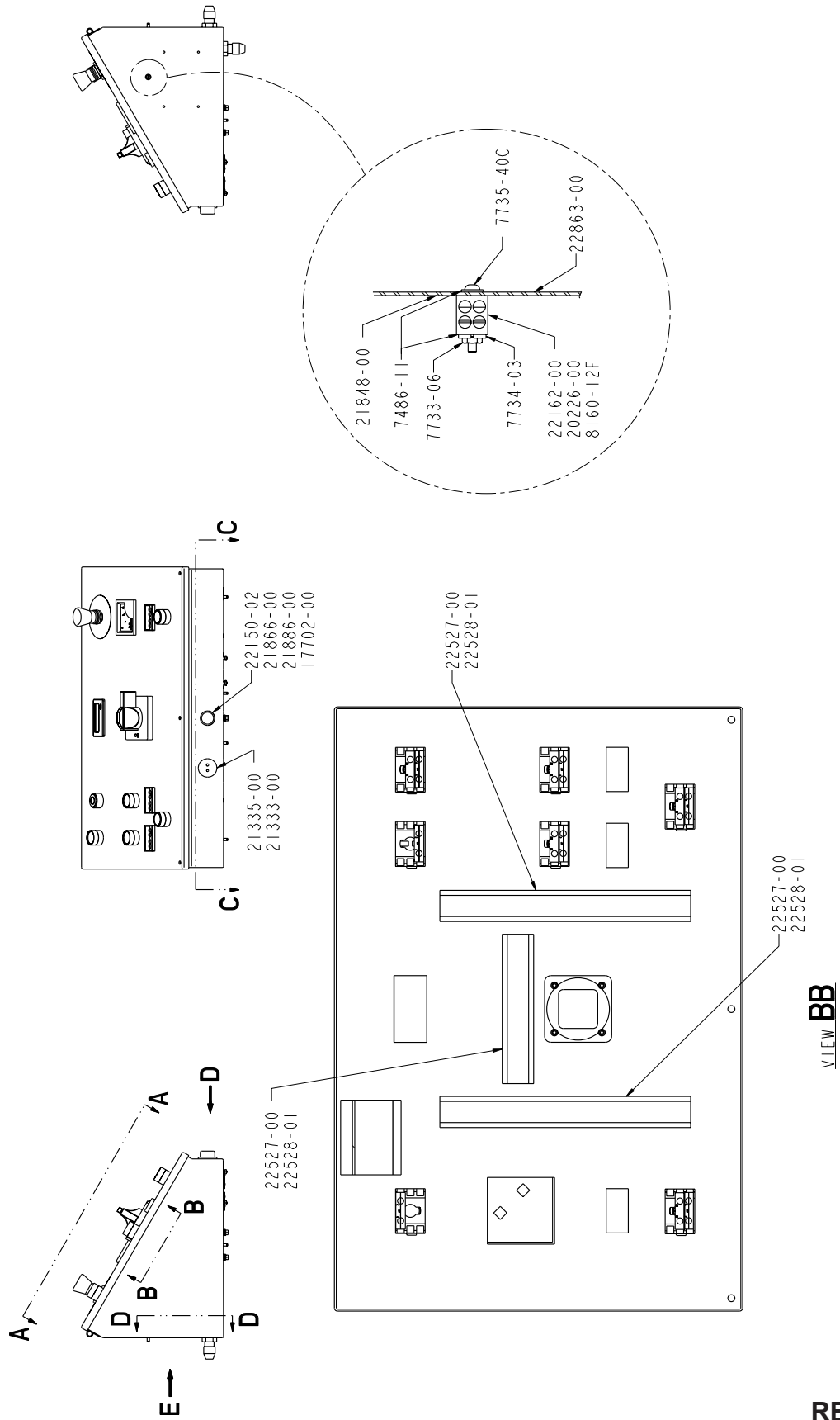

# 22852-XX MH II Control Box Assembly

GLAS-CRAFT P/N	PHASE	A	B	9
22852-02	220 V., 3-PHASE 5 HP., 60 HZ.	22171-01	22174-01	22157-00 (3 REQ'D) 22158-00 (6 REQ'D)
22852-03	380 V., 3-PHASE 5 HP., 50 HZ.	22171-02	22174-02	22157-00 22158-00 (2 REQ'D)
22852-01	220 V., 1 PHASE 5 HP., 60 HZ.	22171-03	22174-03	22157-00 (2 REQ'D) 22158-00 (4 REQ'D)

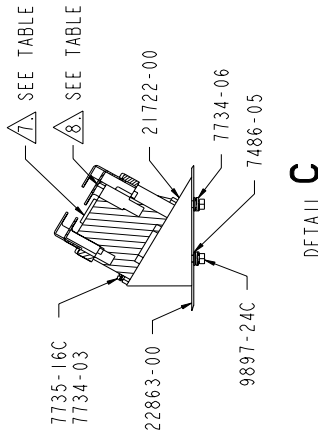
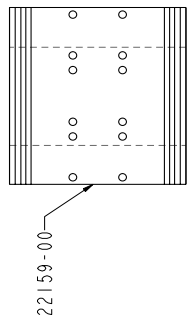
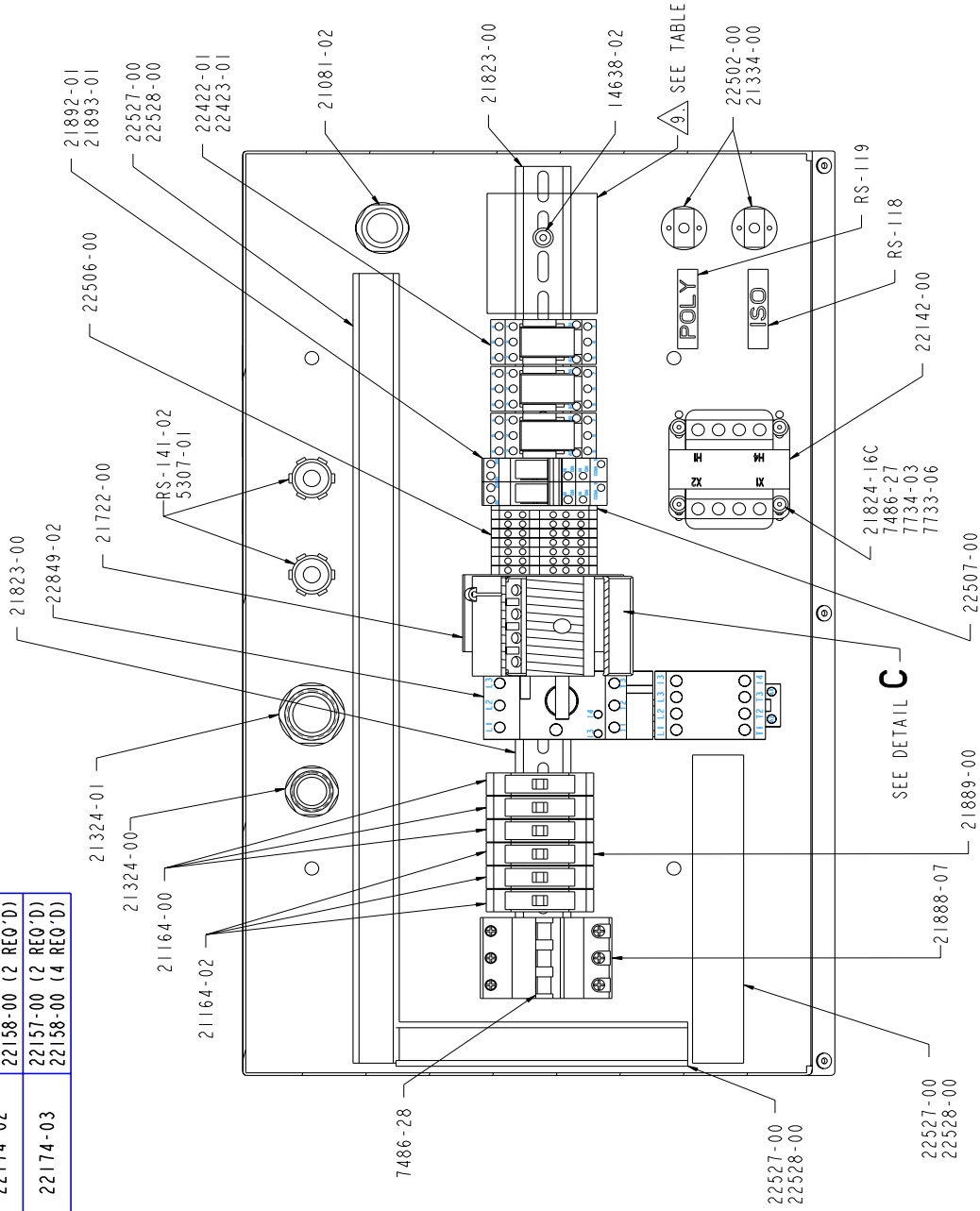

SECTION C-C

# 22852-XX MH II Control Box Assembly

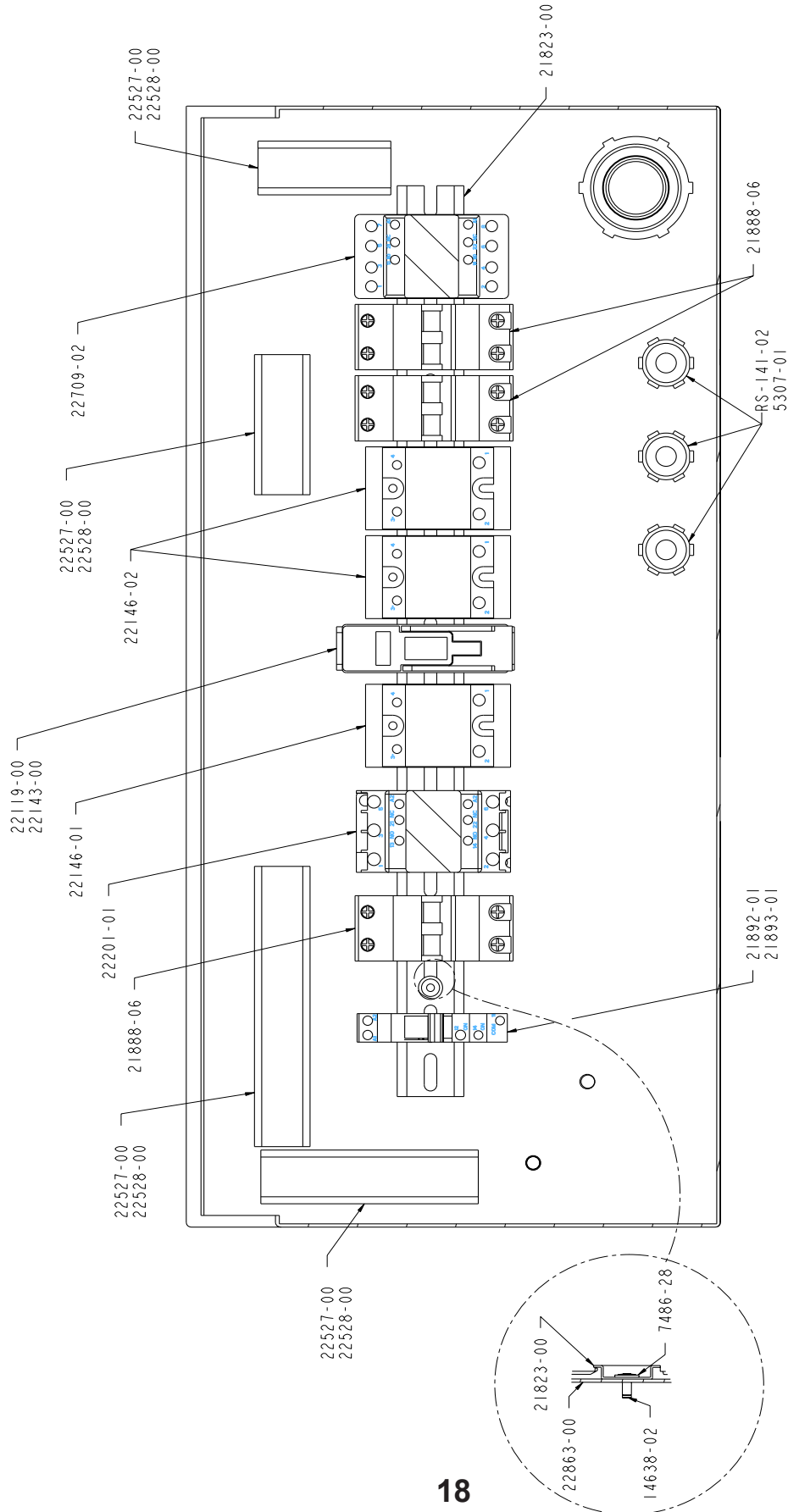

SECTION **D-D**

# 22852-XX MH II Control Box Assembly

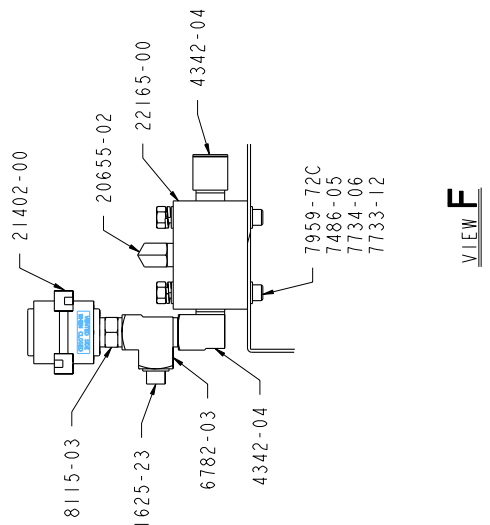
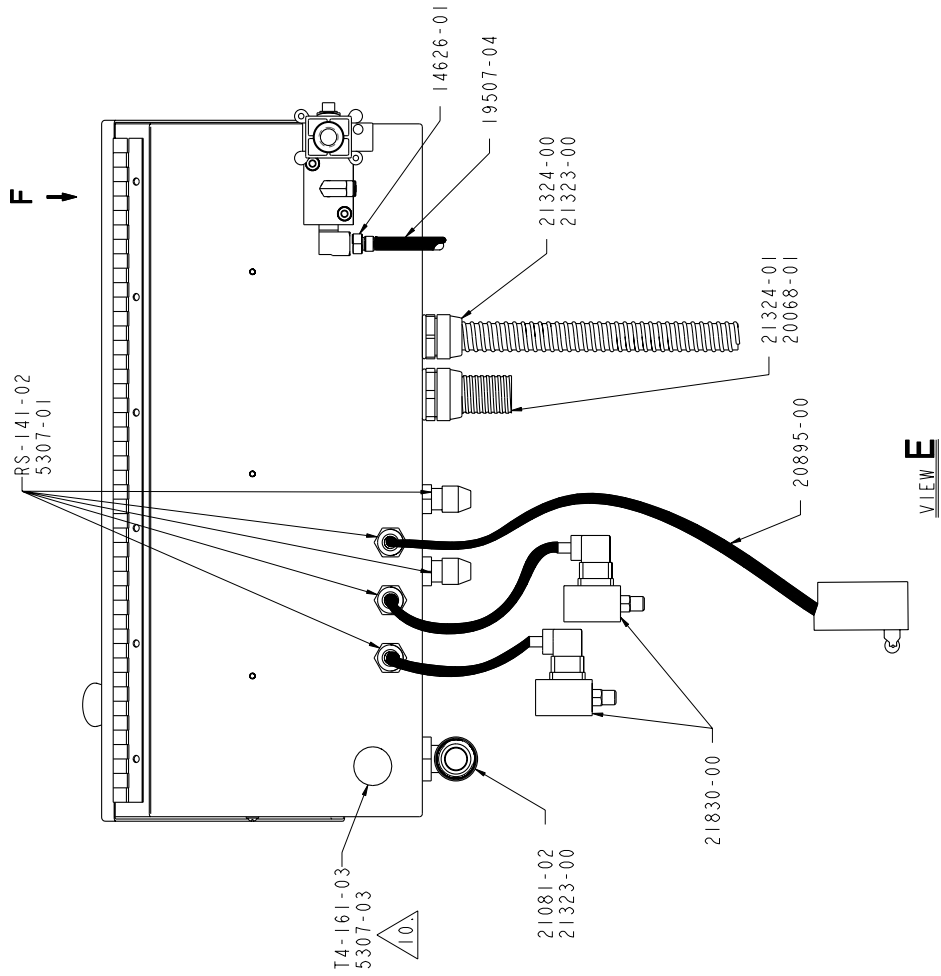

# 22852-XX MH II System Generic Ladder Schematic

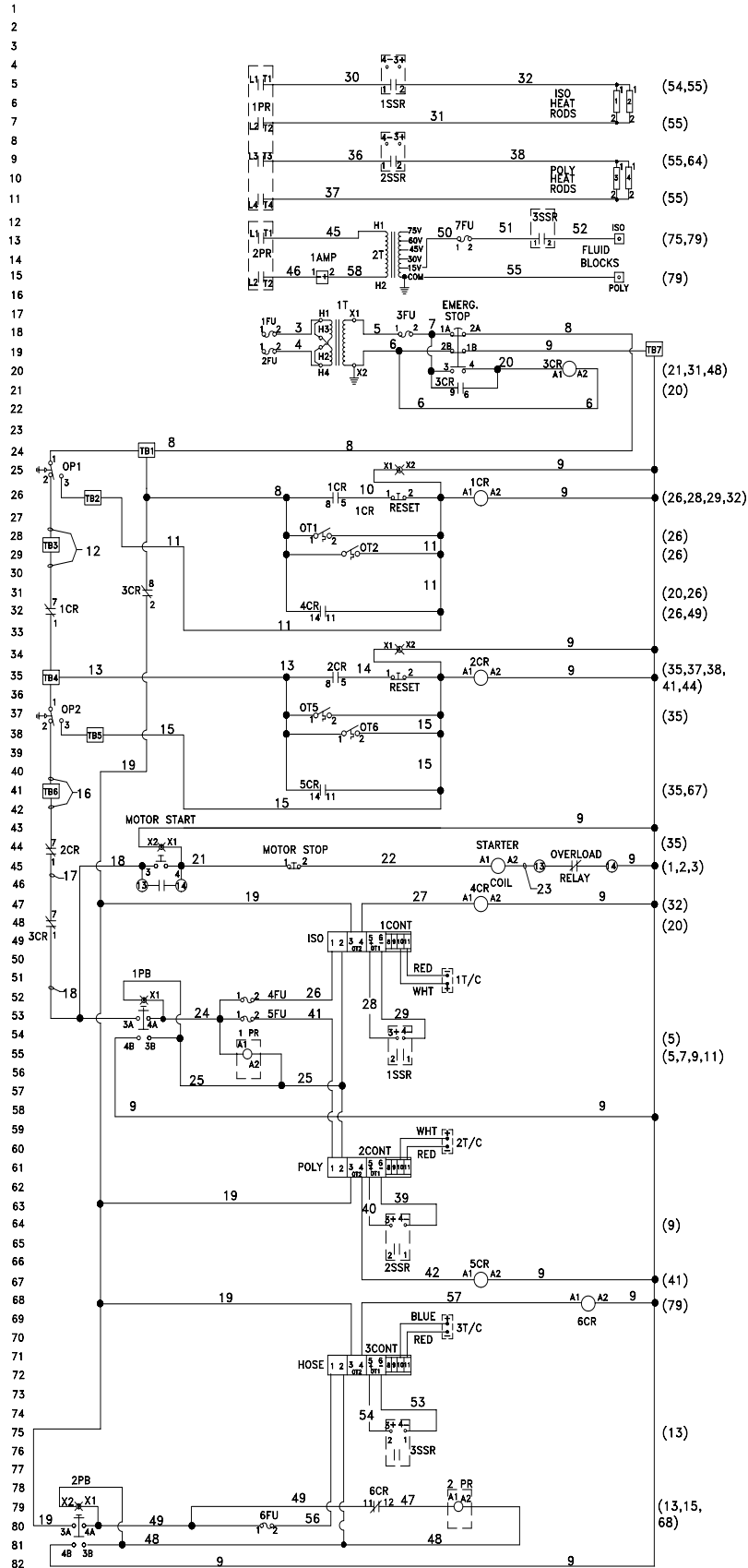

# 22852-XX MH II Control Box Assembly

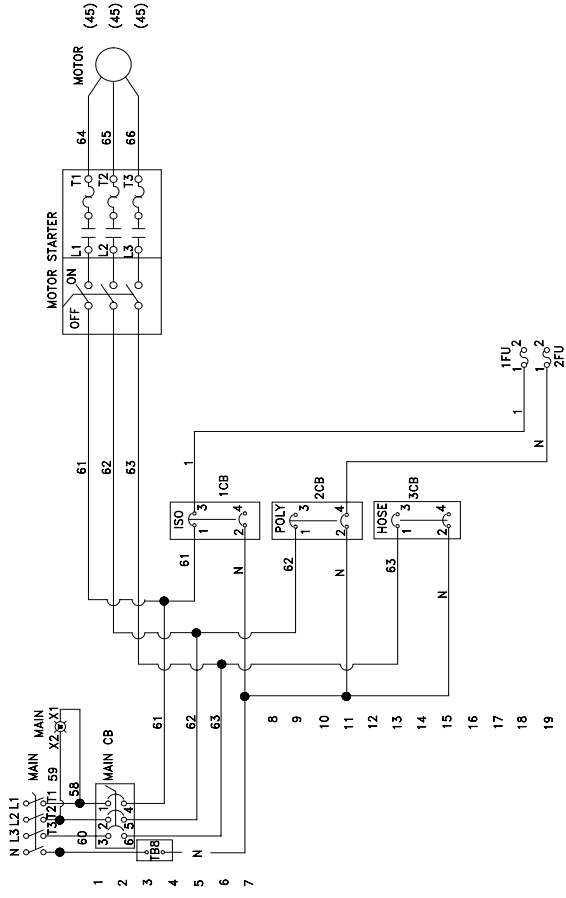

22852-03  
380V, 3-PHASE, 5HP, 50Hz

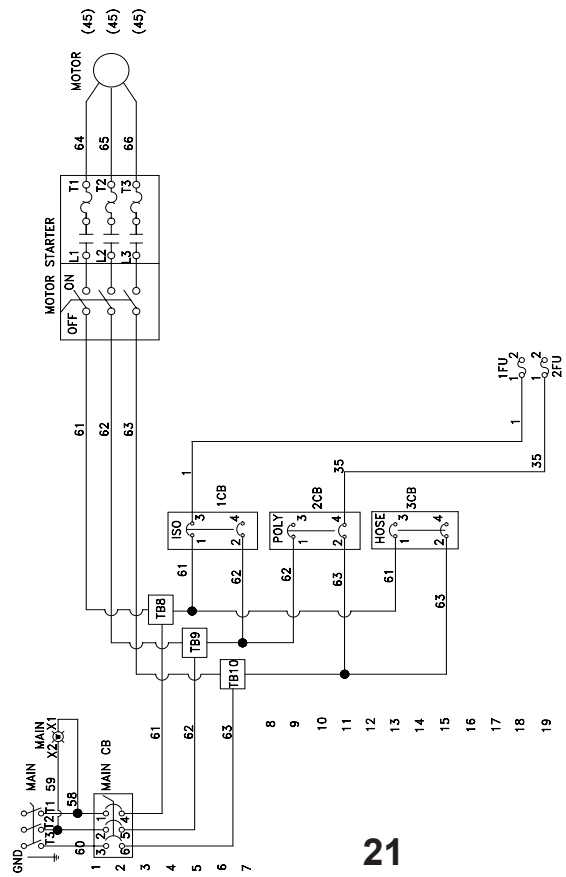

22852-02  
220V, 3-PHASE, 5HP, 60Hz

380V, 3-PHASE 380 VOLTS 50 HZ  
220V, 3-PHASE 220 VOLTS, 60 HZ

# 22852-01 MH II System Ladder Schematic

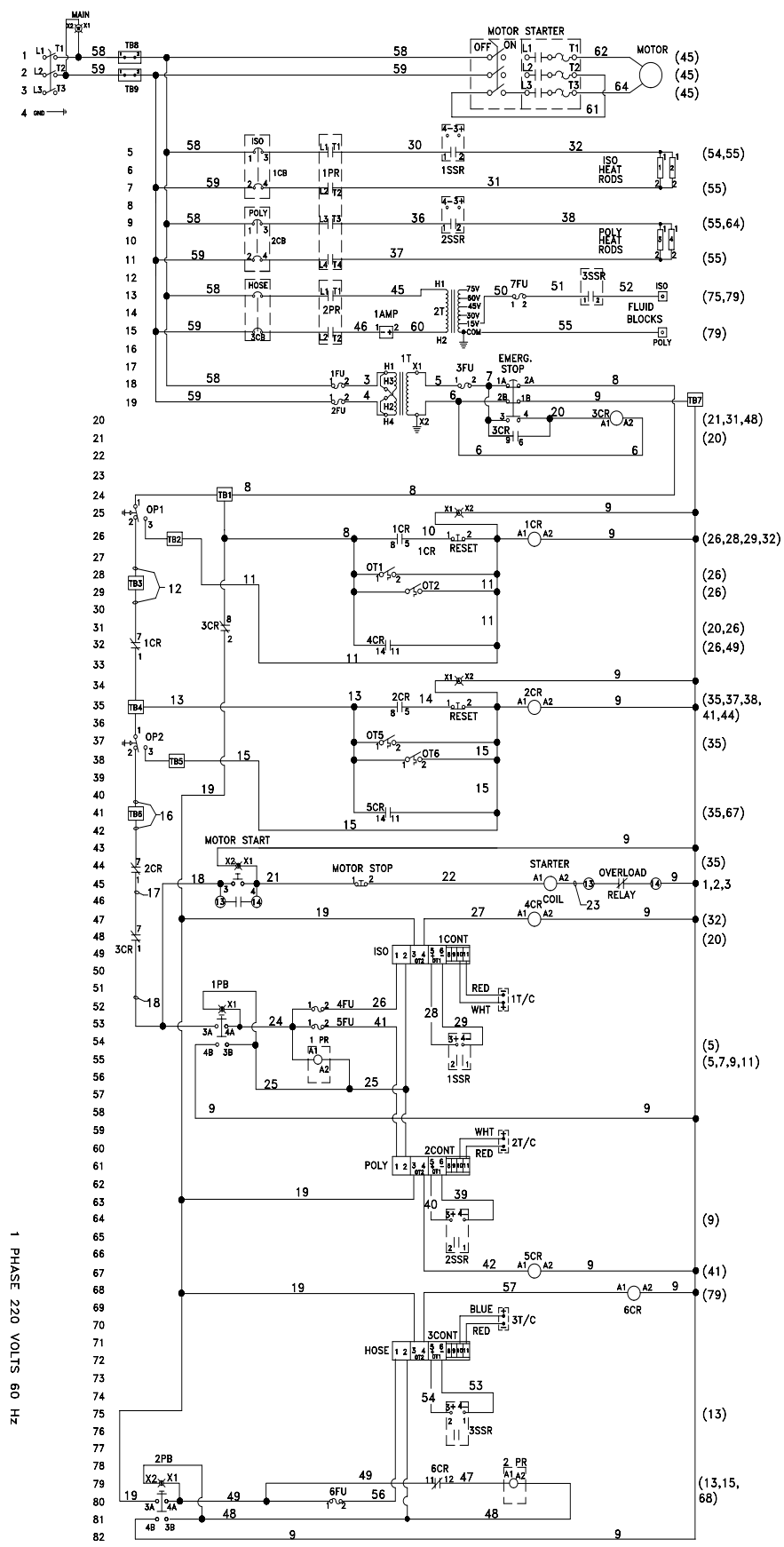

## 22852-XX MH II System Assembly Parts List

PART NUMBER	DESCRIPTION
RS-118	ISO DECAL
RS-119	POLY DECAL
RS-121	HOSE DECAL
RS-124	MAIN DECAL
RS-126	HOSE CURRENT DECAL
RS-127	HOSE CONTROL DECAL
RS-141-02	CORD GRIP
T4-161-03	CABLE RELIEF CONNECTOR
13424-01	CABLE TIE
14626-01	FITTING
14638-02	RIVET
1625-23	FITTING
17702-00	NEON PILOT LAMP
20068-01	FLEXIBLE CONDUIT
20226-00	SET SCREW
20655-02	ELBOW FITTING
20895-00	CABLE
21081-02	SWIVELLOK CONNECTOR
21110-00	#6 WIRE
21112-00	COUNTER
21150-00	TERMINAL LUG
21164-00	1/2 AMP FUSE
21164-02	2 AMP FUSE
21324-00	CONDUIT CONNECTOR
21324-01	CONDUIT CONNECTOR
21333-00	WIRE THERMOCOUPLE-GRADE
21334-00	WIRE THERMOCOUPLE-GRADE
21335-00	PANEL JACK
21356-02	MICROPROCESSOR CONTROLLER
21361-00	MINIATURE LAMP
21402-00	3/8NPT 3-WAY LOCKOUT VALVE
21722-00	MOUNTING BRACKET
21823-00	DIN RAIL
21824-16C	SCREW
21830-00	HIGH PRESSURE SWITCH
21848-00	PE DECAL
21854-00	LATCHED PUSH BUTTON
21862-00	MOMENTARY PUSH BUTTON
21863-00	PUSH BUTTON
21864-00	EMERGENCY PUSH BUTTON
21865-01	CONTACT BLOCK N.O.
21865-02	CONTACT BLOCK N.C.
21866-00	COUPLING PLATE

PART NUMBER	DESCRIPTION
21867-02	INSCRIPTION CAP BLACK
21867-03	INSCRIPTION CAP WHITE
21867-04	INSCRIPTION CAP WHITE
21867-05	INSCRIPTION CAP WHITE
21886-00	LAMP MOUNTING BLOCK
21887-01	YELLOW CAP
21887-02	OPAQUE CAP
21887-03	GREEN CAP
21888-06	CIRCUIT BREAKER
21888-07	CIRCUIT BREAKER
21889-00	FUSEHOLDER
21892-01	FINDER RELAY
21893-01	SOCKET RELAY
22104-00	EMERGENCY STOP DECAL
22119-00	63AMPS FUSE BLOCK
22142-00	TRANSFORMER BOX
22143-00	63AMP FUSE
22146-01	SOLID STATE RELAY
22146-02	SOLID STATE RELAY
22150-02	OPAQUE PILOT LIGHT
22154-00	HYDRAULIC POWER DECAL
22159-00	BLOCK COVER
22162-00	CONDUCTOR CONNECTOR
22163-00	30A AMMETER
22165-00	SPOOL VALVE MANIFOLD
22178-00	ON/OFF POWER SWITCH
22201-01	MECHANICAL CONNTACTOR
22422-01	3 POLE 10AMP RELAY
22423-01	RELAY SOCKET
22502-00	PANEL JACK
22506-00	2IN/2OUT TERMINAL
22507-00	TERMINAL END COVER
22527-00	WIRING DUCT COVER
22528-00	WIRING DUCT
22528-01	WIRING DUCT
22709-02	MECHANICAL CONNTACTOR
22753-00	OVERPRESSURE DECAL
22849-02	CIRCUIT CONNTROLER
22860-00	MH-2 DECAL
22863-00	MH-2 CONTROL BOX
3201	PLASTIC TONGUE RING

## 22852-XX MH II System Assembly Parts List

<b>PART NUMBER</b>	<b>DESCRIPTION</b>
3800-03	WIRE
3800-08	WIRE
4160-00	TERMINAL LUG RING
4342-04	ELBOW FITTING
5307-01	CONDUIT NUT
5307-03	CONDUIT NUT
6782-03	FITTING
7361-00	TERMINAL RING LUG
7486-05	FLAT WASHER
7486-11	FLAT WASHER
7486-27	FLAT WASHER
7486-28	FLAT WASHER
7733-06	HEX NUT
7733-12	HEX NUT
7734-03	LOCK WASHER
7734-06	LOCK WASHER
7735-40C	SCREW
7959-72C	SCREW
8115-03	FITTING
8160-12F	SCREW
8846-03	WIRE
8847-08	WIRE
9897-24C	SCREW

# 21835-00 Fluid Section Assembly

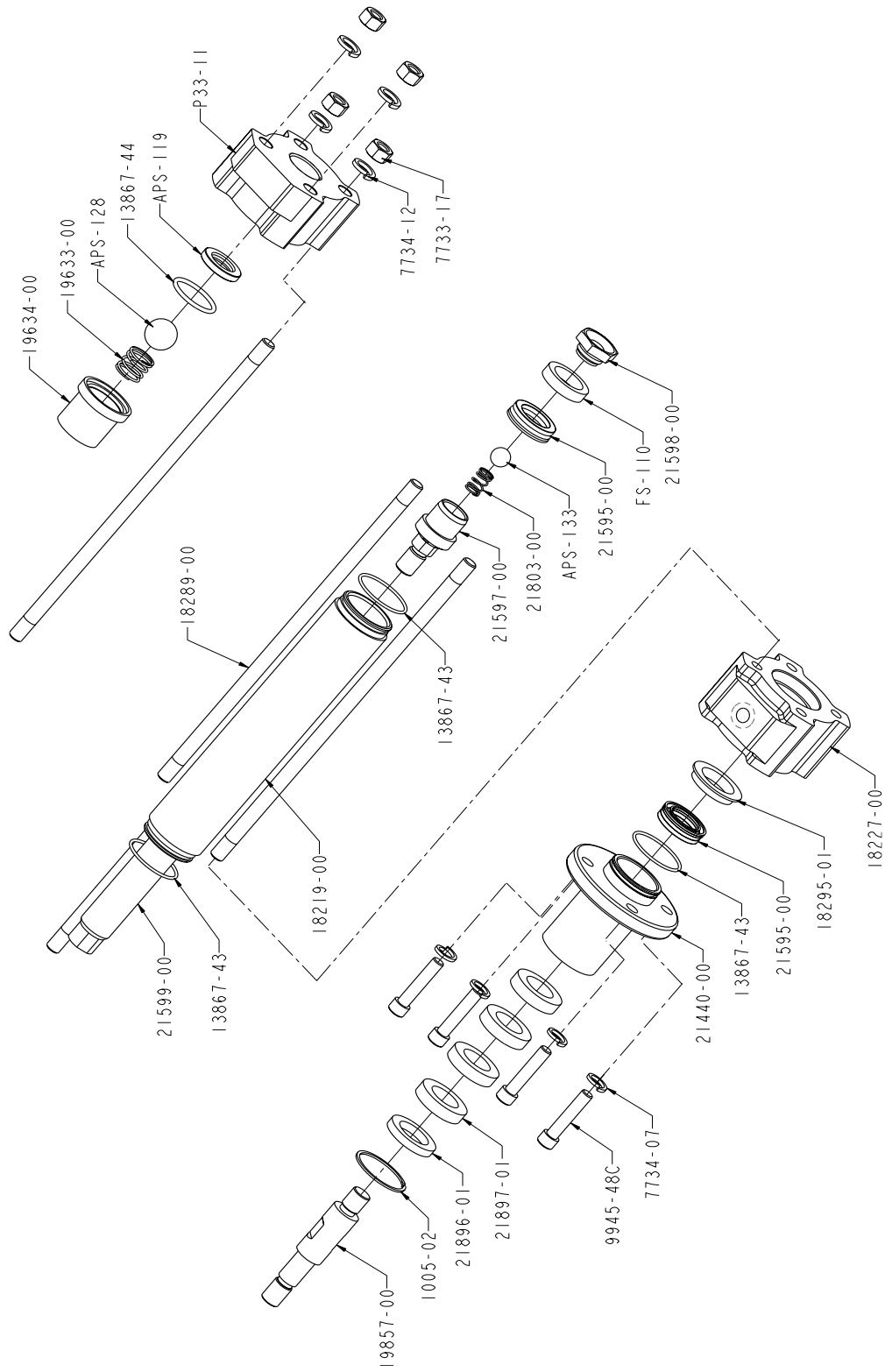

## 21835-00 Fluid Section Assembly Parts List

PART NUMBER	DESCRIPTION	QTY.
APS-119	FOOT VALVE SEAT	1
APS-128	CHROME BALL	1
APS-133	SST BALL	1
FS-110	NYLON PISTON GUIDE	1
P33-11	PUMP BASE	1
1005-02	SNAP RING	1
13867-43	O-RING	3
13867-44	O-RING	1
18219-00	PUMP CYLINDER	1
18227-00	AIRLESS PUMP HEAD	1
18289-00	PUMP TIE ROD	4
18295-01	SUPPORT WASHER	1
19633-00	COMPRESSION SPRING	1
19634-00	FOOT VALVE HOUSING	1
19857-00	PUMP SHAFT EXTENSION	1
21440-00	SOLVENT CUP ADAPTER	1
21595-00	PUMP SEAL	2
21597-00	TRANSFER HOUSING	1
21598-00	TRANSFER SEAT	1
21599-00	PUMP SHAFT	1
21803-00	COMPRESSION SPRING	1
21896-01	PACKING RETAINER	1
21897-01	FELT WIPER	4
7733-17	HEX NUT	4
7734-07	LOCK WASHER	4
7734-12	LOCK WASHER	4
9945-48C	SCREW	4

# 22075-00 Heat Exchanger Assembly

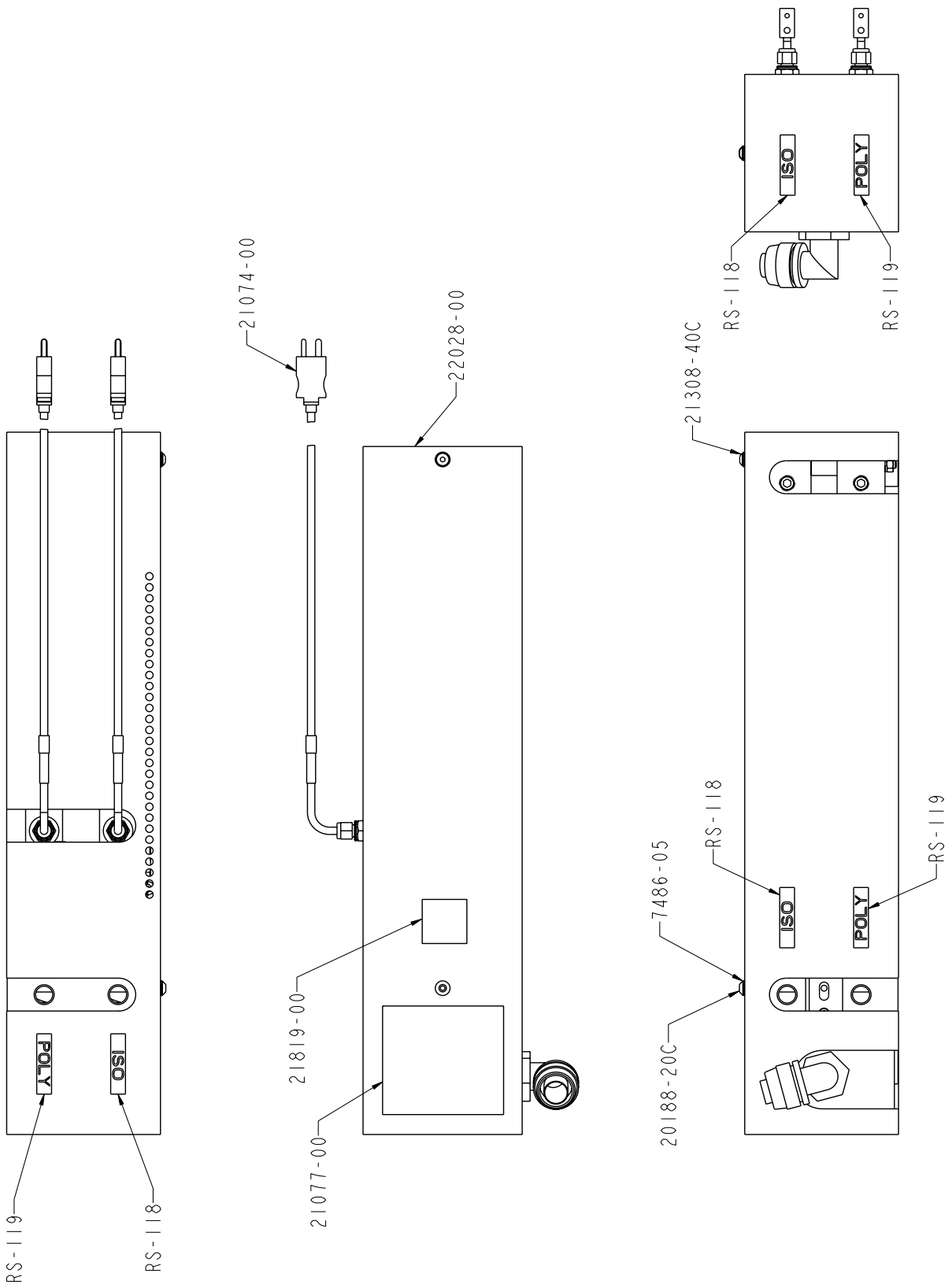

# 22075-00 Heat Exchanger Assembly

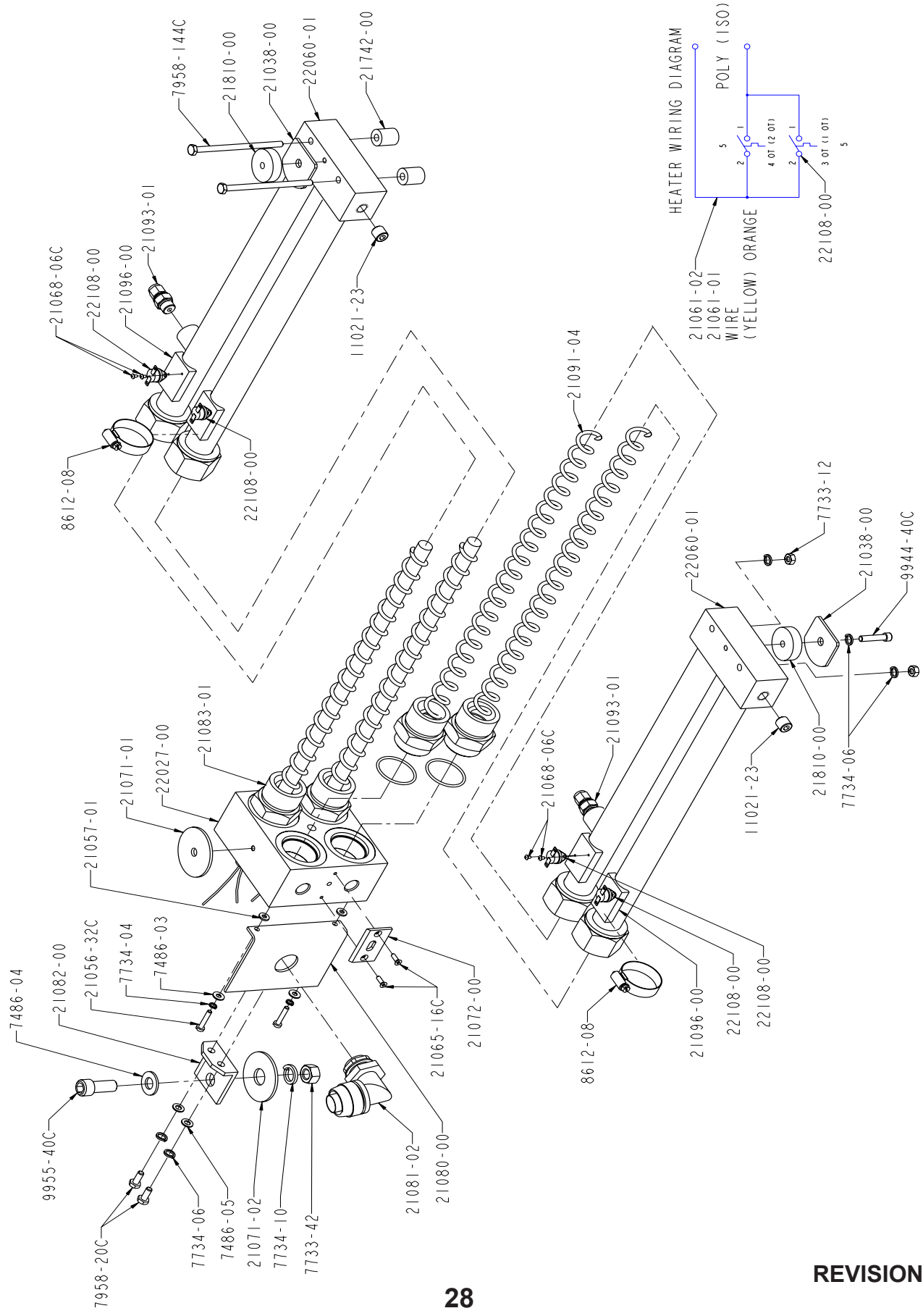

22075-00 Heat Exchanger Assembly

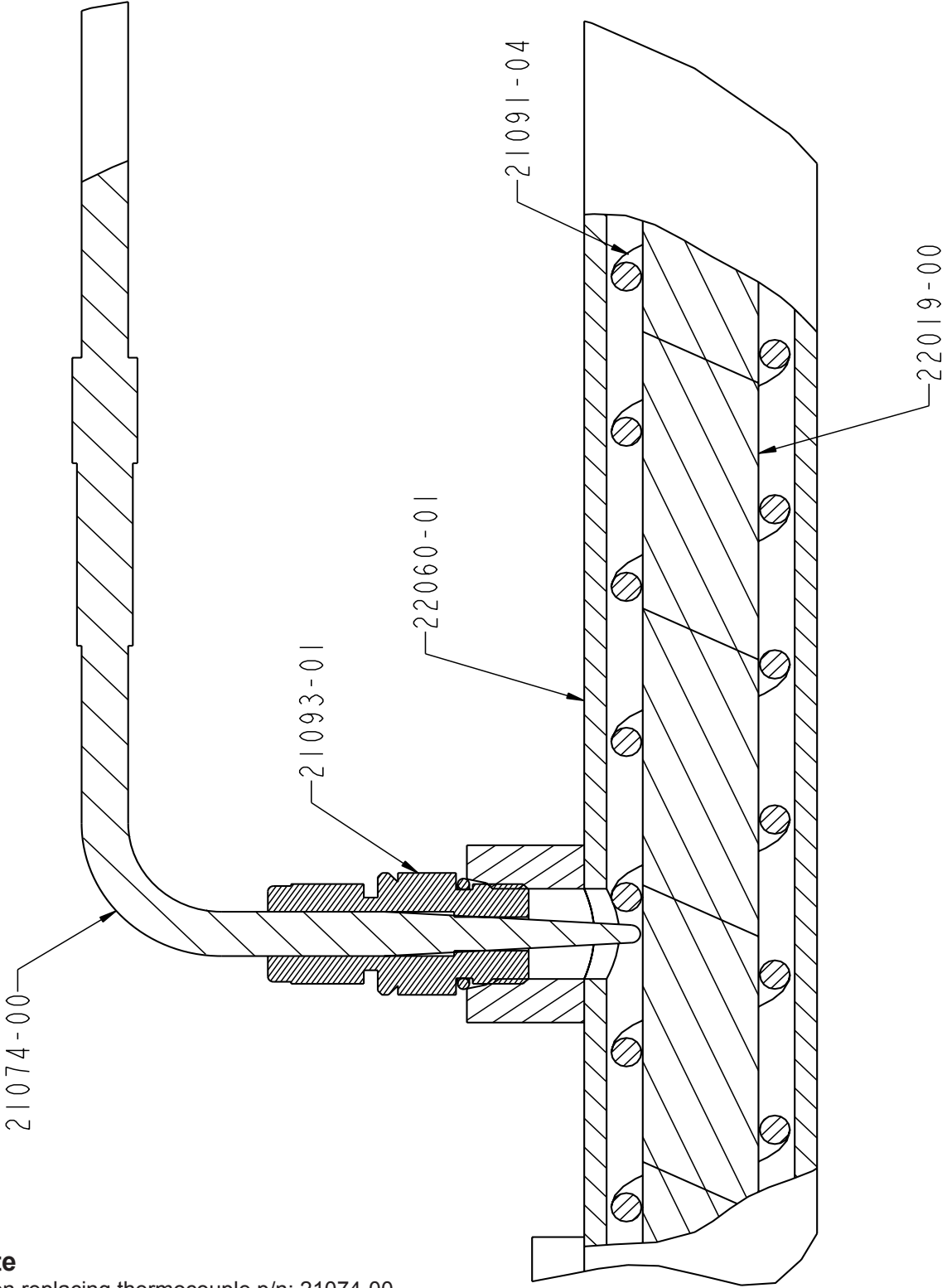

**Note**  
When replacing thermocouple p/n: 21074-00, use kit p/n: 21214-01. Be sure thermocouple is touching heater element before tightening.

## 22075-00 Heat Exchanger Assembly Parts List

PART NUMBER	DESCRIPTION	QTY.
RS-118	ISO DECAL	3
RS-119	POLY DECAL	3
11021-23	PIPE PLUG	2
20188-20C	SCREW	1
21038-00	HARD FIBER WASHER	2
21056-32C	SCREW	2
21057-01	GLASS FIBER WASHER	2
21061-01	WIRE	0
21061-02	WIRE	0
21065-16C	SCREW	2
21068-06C	SCREW	8
21071-01	HARD FIBER WASHER	1
21071-02	HARD FIBER WASHER	1
21072-00	INSULATOR PAD	1
21074-00	THERMOCOUPLE	2
21077-00	DANGER HIGH VOLTAGE DECAL	1
21080-00	MOUNTING BRACKET CONNECTOR	1
21081-02	SWIVELLOK CONNECTOR	1
21082-00	MOUNTING BRACKET	1
21091-04	TURBULATOR SPRING	4
21093-01	FITTING	2
21096-00	THERMOSTAT	4
21308-40C	SCREW	1
21742-00	END CAP SPACER	2
21810-00	COVER SPACER	2
21819-00	LIVE WIRE DECAL	1
22019-00	HEATER ELEMENT	4
22027-00	END PLATE	1
22028-00	HEATER COVER	1
22060-01	SENSOR TUBE ASSEMBLY	2
22108-00	OVERTEMP SWITCH	4
7486-03	FLAT WASHER	2
7486-04	FLAT WASHER	1
7486-05	FLAT WASHER	4
7733-12	HEX NUT	2
7733-42	HEX NUT	1
7734-04	LOCK WASHER	2
7734-06	LOCK WASHER	5
7734-10	LOCK WASHER	1
7958-144C	SCREW	2
7958-20C	SCREW	2
8612-08	HOSE CLAMP	4
9944-40C	SCREW,SHDC,SS,.250-20X	1
9955-40C	SCREW,SHDC,CS,.500-13X	1

# 19524-01 MH II Hose Assembly

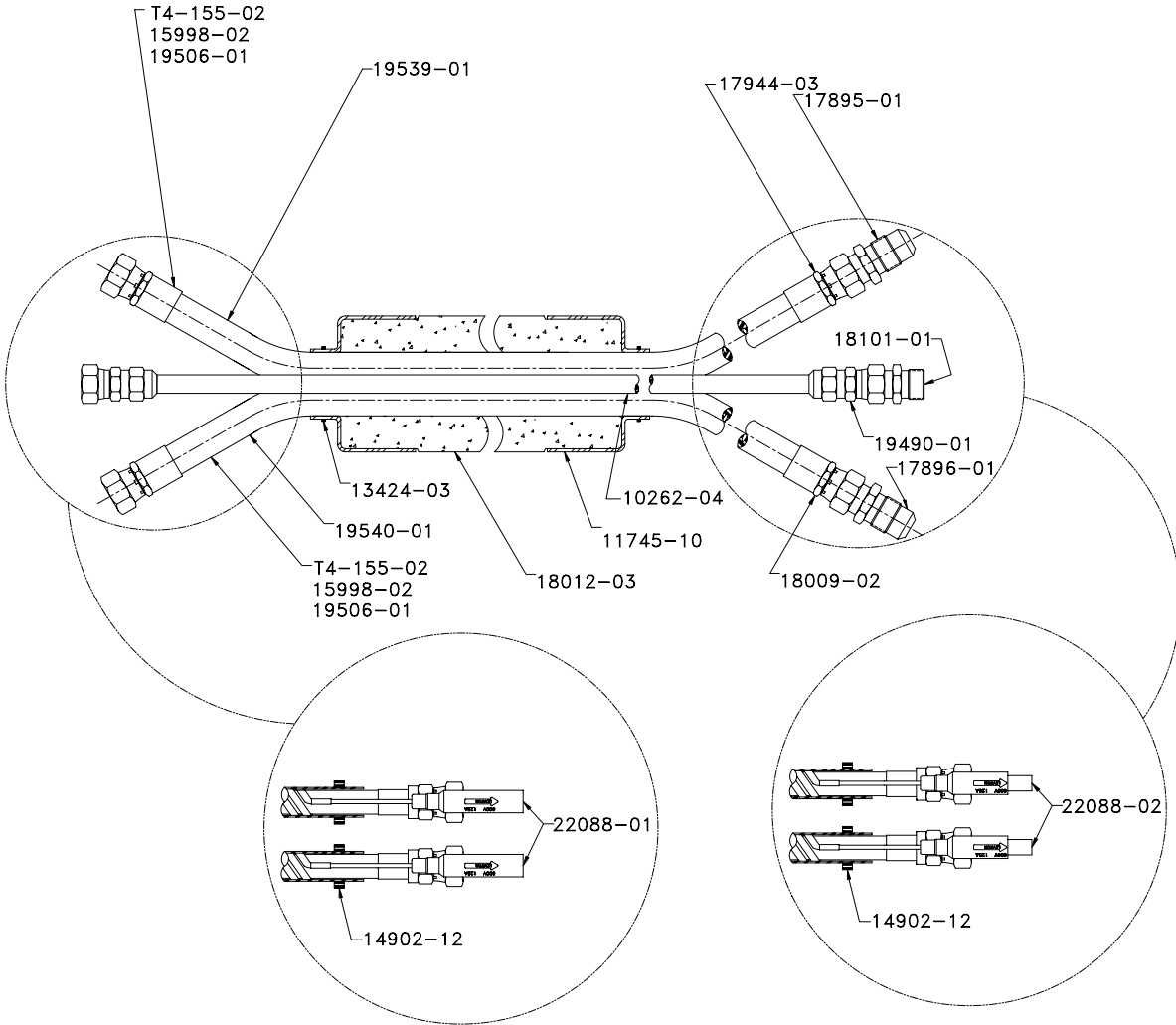

PART NUMBER	DESCRIPTION
T4-155-02	3/8 MATERIAL HOSE
10262-04	NYLON FLUID HOSE
11745-10	HEAT SHRINK TUBING SHRINK
13424-03	CABLE TIE
13424-05	CABLE TIE
14902-12	HOSE CLAMP
15998-02	NEOPRENE TUBING
17895-01	UNION FITTING
17896-01	UNION TUBE FITTING
17944-03	HOSE FITTING
18009-02	HOSE FITTING
18012-03	HEATED HOSE COVER
18101-01	ADAPTER FITTING
19490-01	HOSE FITTING
19506-01	COPPER STRIP
22088-01	MALE ELECTRIC PLUG ASSEMBLY
22088-02	FEMALE ELECTRIC PLUG ASSEMBLY
22089-00	BUTT CONNECTOR

# Typical System Layout Diagram

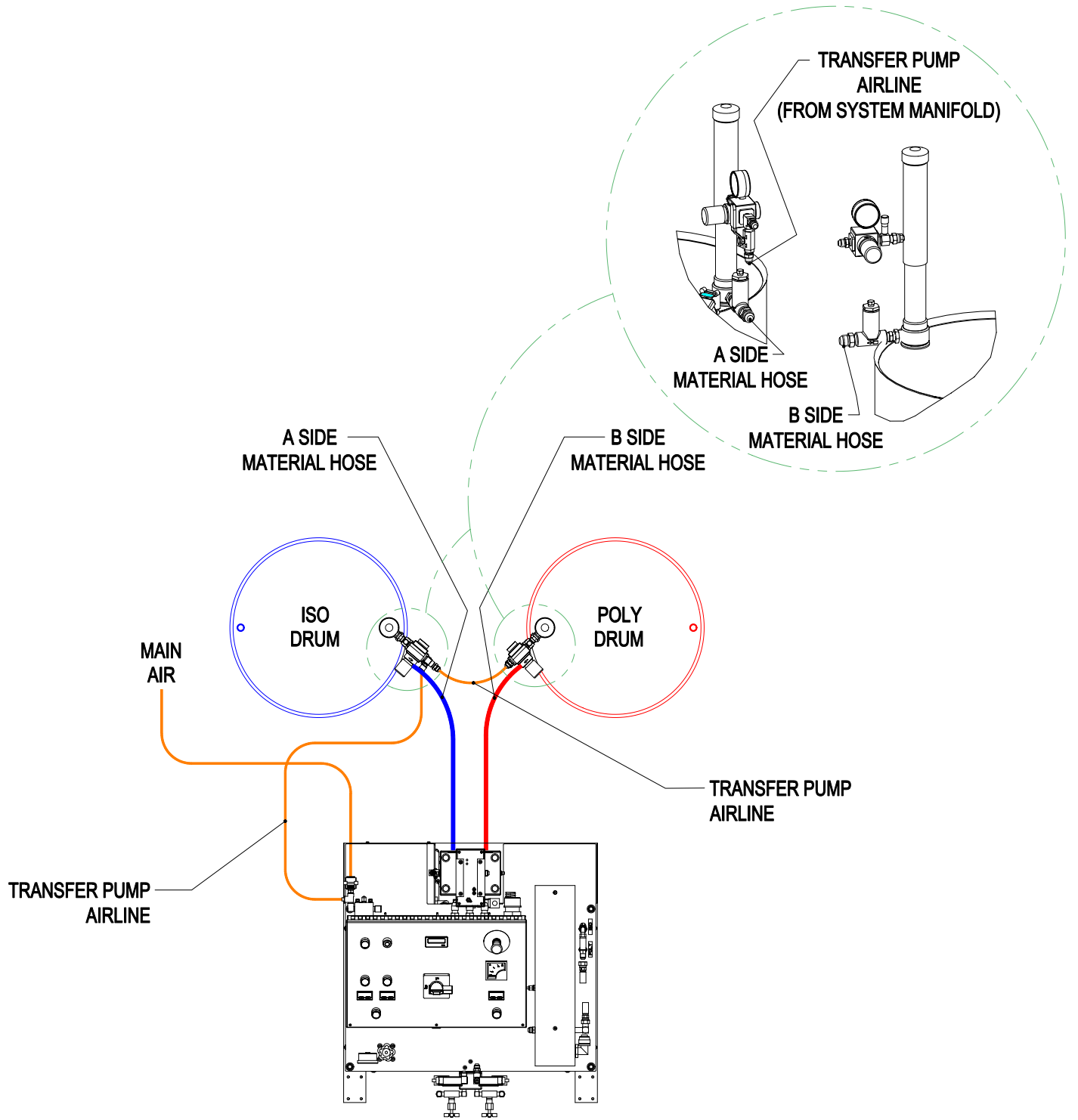

# Typical System Hose Connection 50 Ft. Application

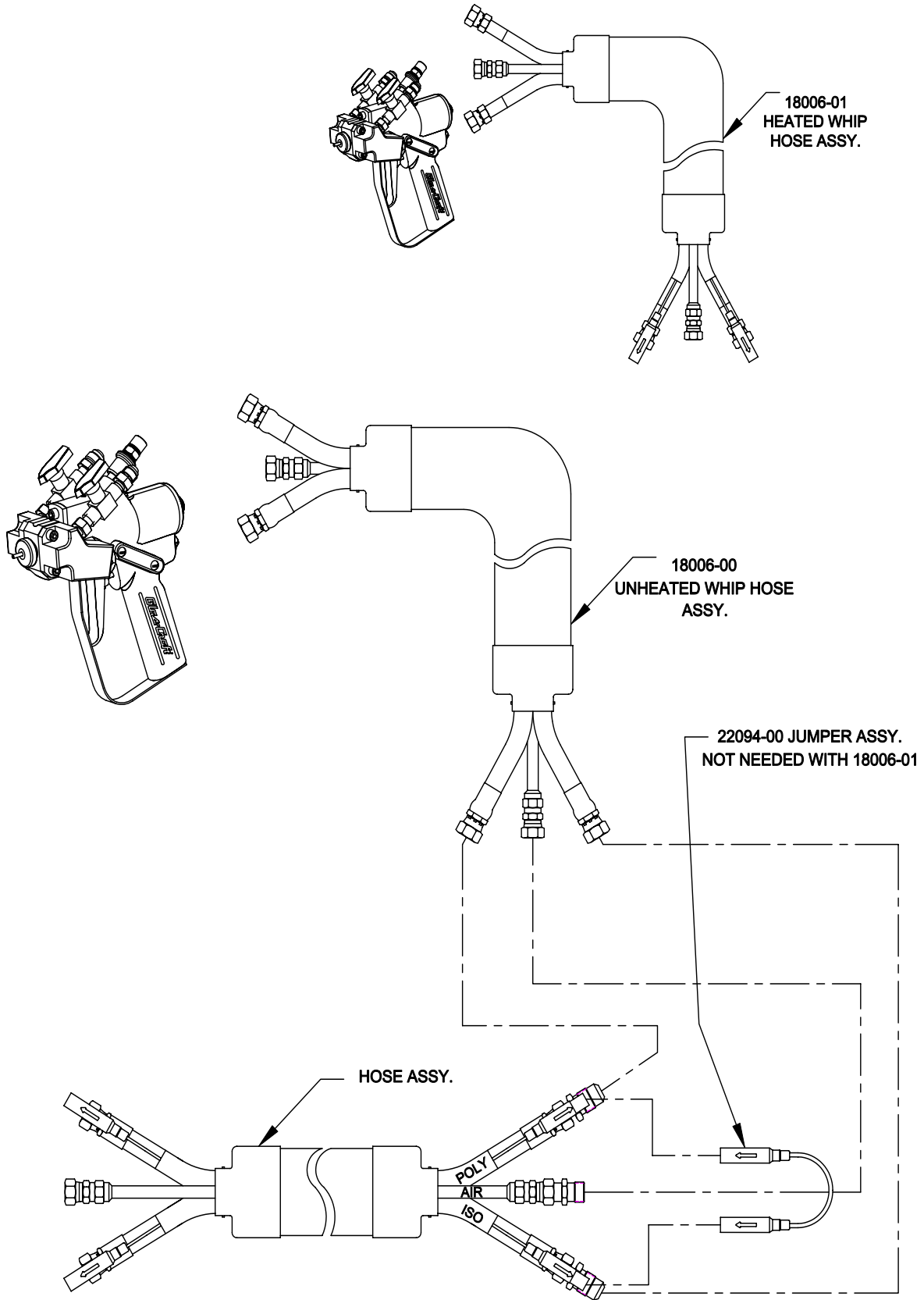

# Typical System Hose Connection 100-300 Ft. Applications

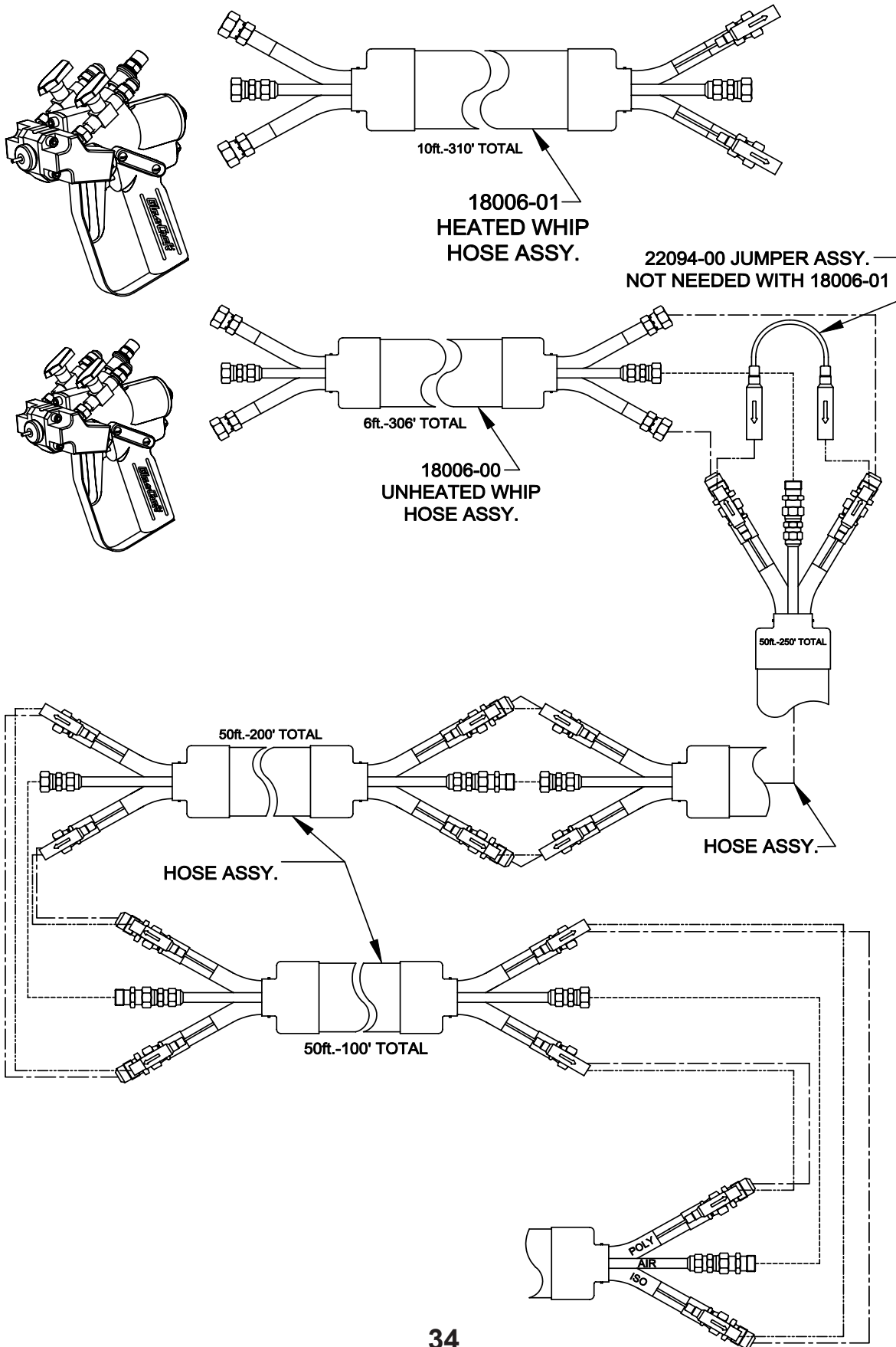

# Safety

## Safe Handling And Use Of Urethane Foam Equipment

### Introduction

Any tool, if used improperly, can be dangerous. Safety is ultimately the responsibility of those using the tool. In like manner, safe operation of polyester processes is the responsibility of those who use such processes and those who operate the equipment. This manual outlines procedures to be followed in conducting polyester operations safely.

All personnel involved in dispensing operations should read and understand this manual. It is most important that equipment operators, maintenance, and supervisory personnel understand the requirements for safe operation.

This manual cannot answer every circumstance; each user should examine his own operation, develop his own safety program and be assured that his equipment operators follow correct procedures. GlasCraft hopes that this manual is helpful to the user and recommends that the precautions in this manual be included in any such program.

Urethane foam systems are comprised of several different chemical compounds, some of which may be hazardous if improperly used.

### CAUTION

*Particular caution must be taken with respect to the vapors released during the use of urethane foam systems.*

Isocyanate compounds are used in urethane foaming operations. The medical history of persons who may be exposed to such isocyanates should be examined. It is recommended that individuals with a history of chronic respiratory ailments should avoid exposure to all isocyanates.

In addition to the manual, GlasCraft recommends that the user consult the regulations established under the Occupational Safety & Health Act (OSHA), particularly the following sections:

- 1910.94 Pertaining to ventilation.
- 1910.106 Pertaining to flammable liquids.
- 1910.107 Pertaining to spray finishing operations, particularly Paragraph (m)

Organic Peroxides and Dual Component Coatings. Local codes and authorities also have standards to be followed in the operation of your spraying equipment. Chemical manufacturer's recommendations should be obtained and considered. Your insurance carrier will be helpful in answering questions that arise in your development of safe procedures.

### Personnel Safety Equipment

GlasCraft recommends the following Personal Safety Equipment for conducting safe operations of the Polyester Systems:



GlasCraft recommends that the user consult the state and local regulations established for all Safety equipment listed.

### Operating Safely

In operating urethane foam equipment safely, user should make every effort to:

1. Handle chemicals safely.
2. Provide adequate ventilation.
3. Provide adequate safety equipment (gloves, respirators, safety glasses, protective clothing, etc.) for operators and all others working in areas where they may be exposed to the chemicals or their vapors.
4. Avoid operating equipment which has given any indication of malfunction.
5. Become fully acquainted with the equipment and chemicals used.

### Handling Chemicals Safely

Storage of polyisocyanates, diamines, and organic solvents should be isolated and restricted to specially constructed storage rooms. Store chemicals in original containers and according to manufacturer's recommendations listed on the container. Maximum ambient temperatures to which such chemicals should be exposed are specified by the manufacturer and MUST NOT be exceeded either in the storage area or in the spraying or pouring area.

## Safety

To avoid moisture contamination, do not open containers until ready for use. After use, the remaining material should be re-sealed in the original container and stored in areas away from moisture.

During clean-up of spilled isocyanate component, respirators, gloves and eye protection must be worn. Isocyanates which have been spilled can be controlled by covering them with dry sawdust and/or other absorbent, inert materials. Care should be taken to avoid skin contact. The absorbent material and the absorbed isocyanate should be collected promptly, placed in an open-top container, and treated with dilute solutions of ammonium hydroxide and/or alcohol. While being treated in this manner, the material should be in an adequately ventilated area. Clothing on which any material has been spilled should be removed immediately, and cleaned before being worn again.

### Clean-Up Solvents

#### **WARNING**

*A hazardous situation may be present in your pressurized fluid system!*

*Halogenated Hydrocarbon Solvents can cause an explosion when used with aluminum or galvanized components in a closed (pressurized) fluid system (pumps, heaters, filters, valves, spray guns, tanks, etc.).*

*The explosion could cause serious injury, death and/or substantial property damage.*

*Cleaning agents, coatings, paints, etc. may contain Halogenated Hydrocarbon Solvents.*

*Some GlasCraft spray equipment includes aluminum or galvanized components and will be affected by Halogenated Hydrocarbon Solvents.*

There are three key elements to the Halogenated Hydrocarbon (HHC) solvent hazard.

1. **The presence of HHC solvents.** 1,1,1-Trichloroethane and Methylene Chloride are the most common of these solvents. However, other HHC solvents are suspect if used; either as part of paint or adhesives formulation, or for clean-up or flushing.
2. **Aluminum or Galvanized Parts.** Most handling equipment contains these elements. In contact with these metals, HHC solvents could generate a corrosive reaction of a catalytic nature.

3. **Equipment capable of withstanding pressure.** When HHC solvents contact aluminum or galvanized parts inside a closed container, such as a pump, spray gun, or fluid handling system, the chemical reaction can, over time, result in a build-up of heat and pressure, which can reach explosive proportions.

When all three elements are present, the result can be an extremely violent explosion. The reaction can be sustained with very little aluminum or galvanized metal: any amount of aluminum is too much.

The reaction is unpredictable. Prior use of an HHC solvent without incident (corrosion or explosion) does NOT mean that such use is safe. These solvents can be dangerous alone (as a clean-up or flushing agent) or when used as a component of a coating material. There is no known inhibitor that is effective under all circumstances. Furthermore, the mixing of HHC solvents with other materials or solvents, such as MEK, alcohol, and toluene, may render the inhibitors ineffective.

The use of reclaimed solvents is particularly hazardous. Reclaimers may not add any inhibitors, or may add incorrect amounts of inhibitors, or may add improper types of inhibitors. Also, the possible presence of water in reclaimed solvents could feed the reaction.

Anodized or other oxide coatings cannot be relied upon to prevent the explosive reaction. Such coatings can be worn, cracked, scratched, or too thin to prevent contact. There is no known way to make oxide coatings or to employ aluminum alloys, which will safely prevent the chemical reaction under all circumstances.

Several solvent suppliers have recently begun promoting HHC solvents for use in coating systems. The increasing use of HHC solvents is increasing the risk. Because of their exemption from many State Implementation Plans as Volatile Organic Compounds (VOC's), their low flammability hazard, and their not being classified as toxic or carcinogenic substances, HHC solvents are very desirable in many respects.

## Safety

### WARNING

*If you are now using Halogenated Hydrocarbon solvents in pressurized fluid systems having aluminum or galvanized wetted parts,*

**IMMEDIATELY TAKE THE FOLLOWING STEPS:**

- *Empty system, shut-off, completely depressurize in accordance with equipment service instructions.*
- *Remove equipment from service, disassemble in accordance with equipment servicing instructions.*
- *Inspect all parts for corrosion and/or wear. Replace any damaged parts.*
- *Thoroughly clean all parts of the equipment with a non-halogenated solvent and reassemble in accordance with equipment servicing instructions.*
- *Flush equipment with non-halogenated solvent.*
- *Do NOT reuse equipment with HHC solvents or with materials containing such solvents.*
- *Material suppliers and/or container labels should be consulted to ensure that the solvents used are compatible with your equipment.*

### NOTE

*GlasCraft is aware of NO stabilizers available to prevent Halogenated Hydrocarbon solvents from reaction under all conditions with aluminum components in a closed fluid system.*

### TAKE IMMEDIATE ACTION...

*Halogenated Hydrocarbon solvents are dangerous when used with aluminum components in a closed fluid system.*

Consult your material supplier to determine whether your solvent or coating contains Halogenated Hydrocarbon Solvents.

GlasCraft recommends that you contact your solvent supplier regarding the best non-flammable clean-up solvent with the heat toxicity for your application.

If, however, you find it necessary to use flammable solvents, they must be kept in approved, electrically grounded containers.

Bulk solvent should be stored in a well-ventilated, separate building, 50 feet away from your main plant.

You should allow only enough solvent for one day's use in your laminating area.

"NO SMOKING" signs must be posted and observed in all areas of storage or where solvents and other flammable materials are used.

Adequate ventilation (as covered in OSHA Section 1910.94 and NFPA No. 91) is important wherever solvents are stored or used, to minimize, confine and exhaust the solvent vapors.

Solvents should be handled in accordance with OSHA Section 1910.106 and 1910.107.

### Toxicity of Chemicals

GlasCraft recommends that you consult OSHA Sections 1910.94, 1910.106, 1910.107 and NFPA No. 33, Chapter 14, and NFPA No. 91.

Contact your chemical supplier(s) and determine the toxicity of the various chemicals used, as well as the best methods to prevent injury, irritation and danger to personnel.

Also determine the best methods of first aid treatment for each chemical used in your plan

### First Aid

If chemicals containing isocyanate are splashed on the skin, they can produce ill effects. Steps to counteract such effects should be started immediately.

Apply Tincture of Green Soap, full strength, to the contaminated area. If Tincture of Green Soap is not immediately available, wash the exposed area repeatedly with soap and water. Soap and water is not as desirable as using Tincture of Green Soap because many isocyanate components are not easily dissolved in water. In addition, soap and water does not form a barrier to the isocyanate.

After approximately two to four minutes, wash off the Tincture of Green Soap with water. If there is still an indication of isocyanate present, repeat the application. If the isocyanate contamination is on the facial area, care must be taken to avoid getting the Tincture of Green Soap in the eyes.

If the person develops breathing difficulties, oxygen should be administered. Quite often the exposed person will experience residual effects such as coughing spells. **CONTACT PHYSICIAN IMMEDIATELY.**

### WARNING

*Contact a doctor immediately in the event of an injury and give him the information you have collected. If your information includes first aid instructions, administer first aid immediately while you are contacting the doctor.*

## Safety

If a person accidentally swallows isocyanate, large amounts of water should be swallowed immediately. Vomiting should then be induced by patient sticking his finger down his throat, or by swallowing large quantities of warm salt water or warm soapy water. After vomiting, more water should be taken to dilute isocyanate further. CONTACT PHYSICIAN IMMEDIATELY.

### Ventilation

#### **WARNING**

*Hazardous concentrations of some chemical vapors exist before they can be smelled. Chemical component suppliers should be contacted to determine at what concentrations the vapors of the chemicals they supply become dangerous, and the procedures and equipment needed to detect such dangerous concentrations. Such equipment should be obtained.*

*Adequate ventilation must be provided in any area where foam chemicals are sprayed or poured, and wherever the material containers are opened.*

In industrial applications, foaming operations should be restricted to specific areas, and proper ventilation should be provided in these areas to prevent chemical vapors from spreading. Spray foaming operations MUST be restricted to a spray booth where a minimum exhaust of 100 feet per minute at the face of the booth is provided. Special care should be taken to prevent unsuspecting personnel both inside and outside of the plant from being exposed to chemical vapors. The chemical vapors should be exhausted to atmosphere in such a manner and at a sufficiently low concentration that personnel outside the plant are not exposed to dangerous concentrations of chemical vapors. Refer to OSHA Standards, sub-part G, 1910.107 and particularly sub-section (m) for Federal standards. State and local authorities may have applicable statutes or regulations concerning ventilation.

In contractor applications (for example, at a construction site, inside building or other enclosed space), the forced ventilation normally provided is likely to be inadequate. These applications, therefore, usually REQUIRE the use of forced, fresh air respirators for all persons in the areas where foaming operations are conducted or where the chemical vapors are likely to spread.

In industrial and contractor applications, it is advisable to run frequent tests to determine the exact concentration of isocyanate vapor in the air. Industrial equipment is available for making such determinations. Your chemical supplier can recommend such equipment and procedures.

#### **Proper Safety Equipment**

All persons spraying or working in areas where forced air ventilation is not adequate to remove isocyanate vapors from the air MUST use an approved (U.S. Bureau of Mines) fresh air supplied respirator.

Respirators should be regularly inspected, cleaned and disinfected according to good practices. Records must be kept of the inspections. The user MUST have a medical clearance indicating that he can safely use a respirator.

Respirators must fit securely; beards prevent a tight seal around the face. Eye glasses have to be given special attention and contact lenses are prohibited.

Safety goggles, gloves and other protective devices are suggested for operators of foaming equipment. Refer to OSHA Standards, sub-part 1, 1910.132, 1910.133 and 1910.134 for Federal standards.

IF YOU HAVE ANY QUESTIONS REGARDING THE ABOVE PRECAUTIONS OR ANY SERVICE OR OPERATION PROCEDURES, CALL YOUR GLASCRAFT DISTRIBUTOR OR GLASCRAFT, INC.

#### **NOTICE**

*All statements, information and data given herein are believed to be accurate and reliable but are presented without guaranty, warranty or responsibility of any kind expressed or implied. The user should not assume that all safety measures are indicated or that other measures are not required.*

**GlasCraft**  
DISPENSING EXCELLENCE

5845 WEST 82nd STREET, SUITE 102  
INDIANAPOLIS, INDIANA 46278 U.S.A.

PHONE (317) 875-5592

FAX (317) 875-5456

# Installation

## Assembly Instructions

### NOTE

The GlasCraft System is factory assembled. If any questions arise concerning air or electrical connections, please refer to illustrations located in the forward portion of this User Manual or contact your GlasCraft distributor.

### Fluid Line Connection

The material hoses that bring Isocyanate and Polyol chemicals and the air from the machine to the gun should be connected as follows.

### Required Tools:

Opened - end wrenches - 5/8", 3/4", 13/16"

1. Lay hoses out straight.
2. Couple hoses together with supplied union fittings and tighten finger-tight.
3. a. Hold crimp fitting hex (3/4"), and union fitting together, allowing the hose to hold its natural line.  
b. Using the appropriate wrench (A-side 3/4" / B-side 13/16") tighten swivel fitting to union, not allowing crimp fitting or union to turn. Repeat on opposite side of union.

**This practice is required on all connection points.**

- 1) Hose @ machine
- 2) Hose @ gun
- 3) Adding additional hose sections

4. Plug hoses together, The TRU-FLOW hose plugs are a twist-lock design.
  - a. Push plugs together.
  - b. Twist to lock position.

**Once connections are made, tape connections well enough to keep plugs from coming undone, damaged, etc.**

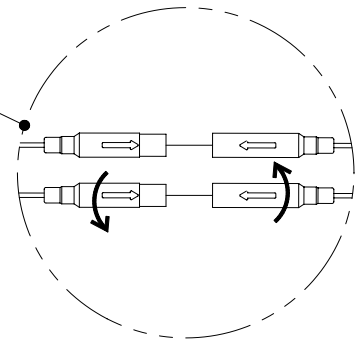
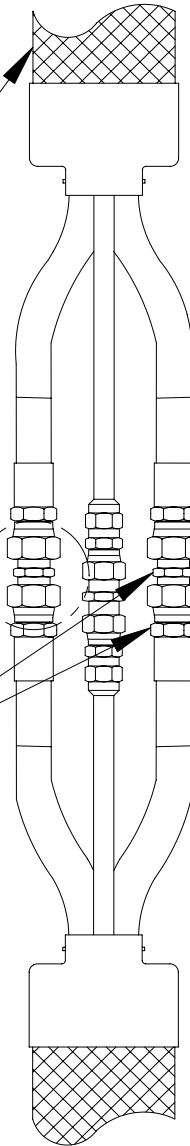

# Installation

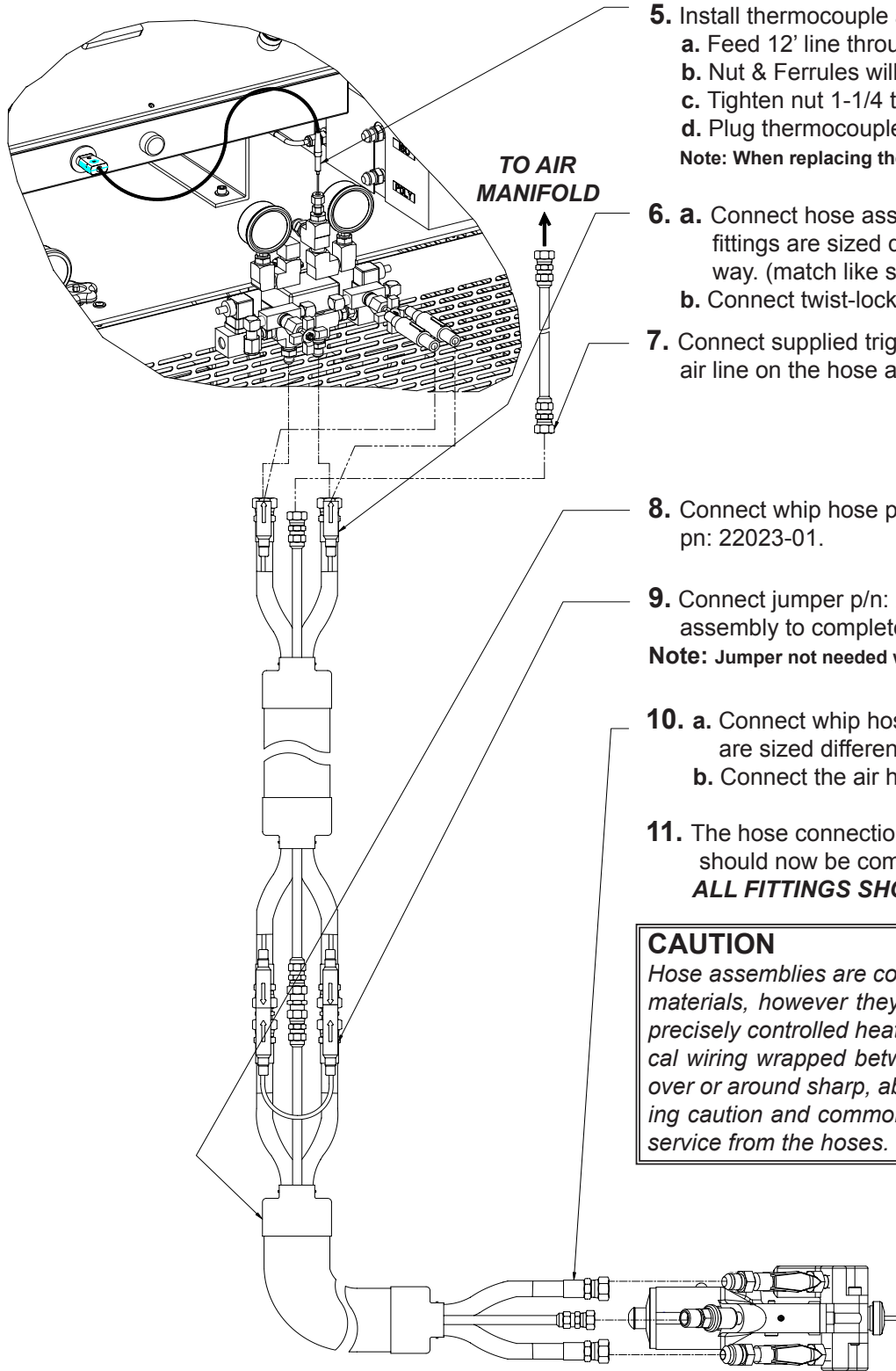

5. Install thermocouple at tee fitting.
  - a. Feed 12' line through hose.
  - b. Nut & Ferrules will lock into fitting.
  - c. Tighten nut 1-1/4 turns past finger tight.
  - d. Plug thermocouple into control box.

Note: When replacing thermocouple use kit p/n: 21214-01.
6.
  - a. Connect hose assembly to the front of the unit. The fittings are sized differently and will attach only one way. (match like sized fittings).
  - b. Connect twist-lock plugs. (see hose installation)
7. Connect supplied trigger air line to the air line on the hose assembly.
8. Connect whip hose p/n: 18006-00 to hose assembly, pn: 22023-01.
9. Connect jumper p/n: 22094-00 to plugs on hose assembly to complete circuit.

Note: Jumper not needed with 18006-01 heated whip hose.
10.
  - a. Connect whip hose assembly to gun. The fittings are sized differently and will attach only one way.
  - b. Connect the air hose to gun.
11. The hose connections between the unit and gun should now be complete.

**ALL FITTINGS SHOULD NOW BE TIGHT**

## CAUTION

Hose assemblies are constructed of durable, rugged materials, however they are not indestructible. To provide precisely controlled heated material, the hoses have electrical wiring wrapped between layers. Avoid dragging hoses over or around sharp, abrasive edges and corners. Exercising caution and common sense will give long, and reliable service from the hoses.

# Installation

## Optional Transfer Pump Installation

P/n: 17661-01

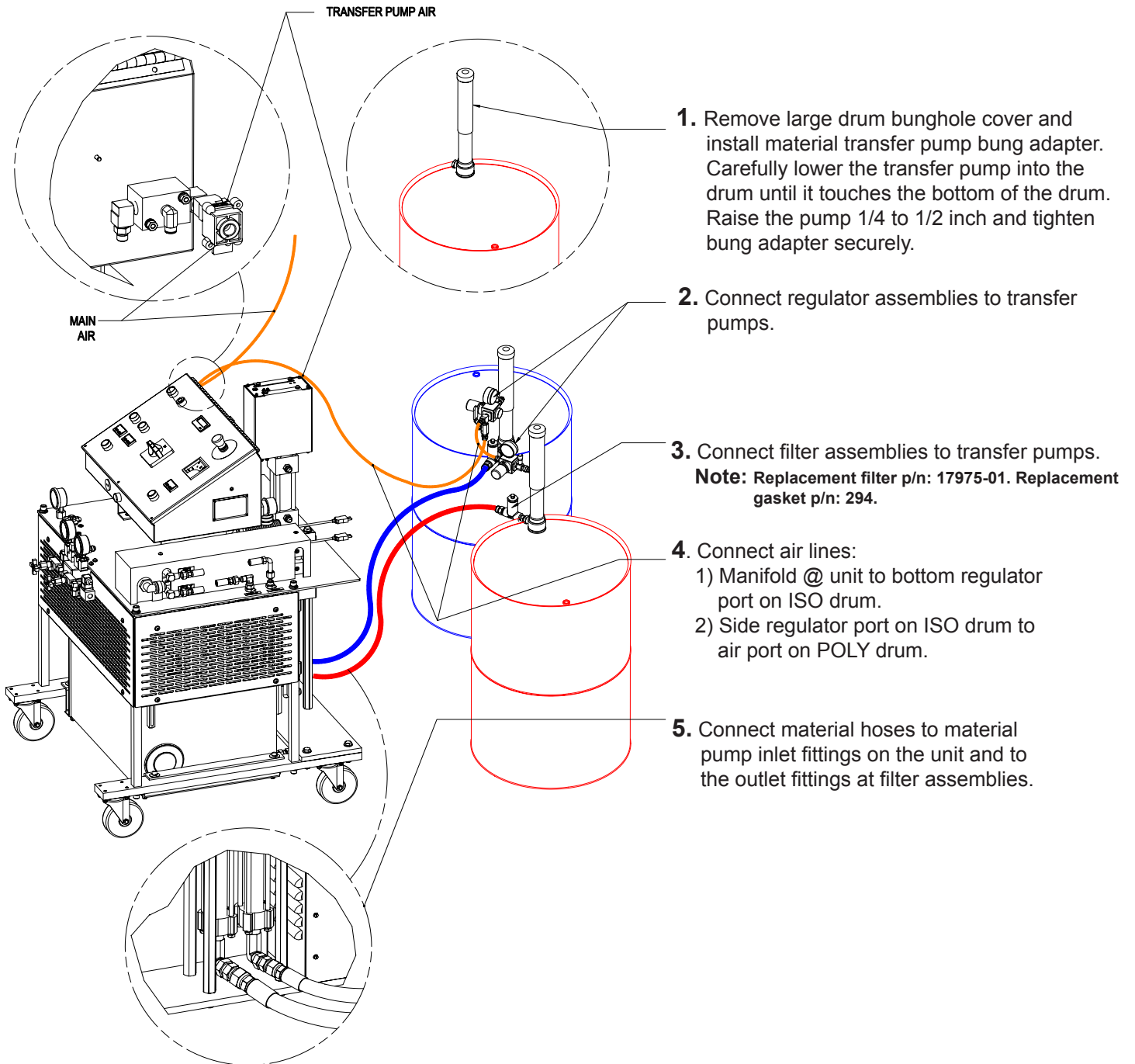

## Optional Air Dryer Kit

P/n: 23410-00 should be installed on the ISO material drum. Replacement cartridge pn: 23409-00.

# Installation

## Electrical Connections

### NOTE

*Electrical connections must be checked on a periodic basis.*

1. 200/208 volt single phase  
L1 L2 GROUND  
If the rotation is not correct, switch any two lead wires.
  
2. 200/240 volt three phase  
L1 L2 L3 GROUND  
If the rotation is not correct, switch any two lead wires.
  
3. 380 volt three phase  
L1 L2 L3 N GROUND  
If the rotation is not correct, switch any two lead wires.
  
4. The transformer can now be set for proper hose length.

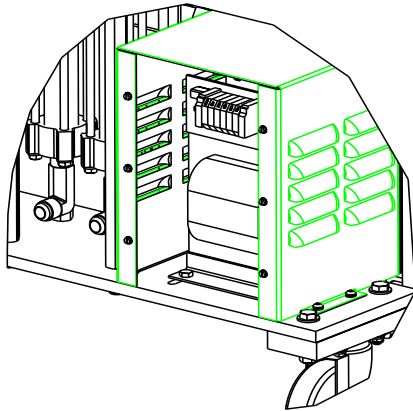

## Hydraulic Power Pack

The hydraulic pack tank is empty when shipped from GlasCraft. The tank **MUST** be filled before operation.

**Tank Capacity: 20 GAL. / 75.5 Liter**

Recommended Hydraulic Fluid: ISO grade 32, 46, or 68. Fluids containing anti-wear additives are recommended for optimum service life.

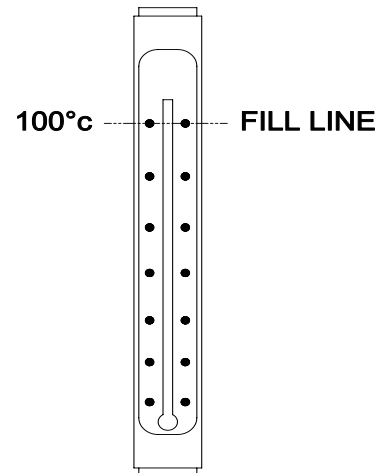
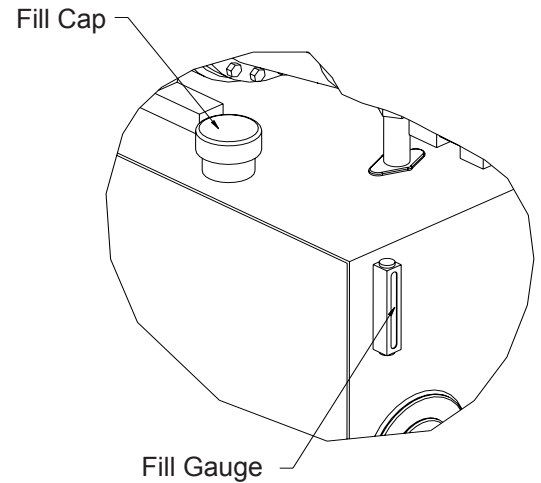

TRANSFORMER		
	PRIMARY	
H1		H2
COM	15V 30V 45V 60V 75V	
TO HOSE		
CONNECTIONS	HOSE LENGTH	
	15V	50 FT
	30V	100 FT
COM	45V	150 FT
(DO NOT	60V	200 FT
MOVE)	60V	250 FT
	75V	300 FT

# Operation

## WARNING

Never leave machine unattended while system power is on or system is running.

System running is defined as: preheat cycle of the hose heat, primary heaters, or any pump operation.

Machine operators must be familiar with the component functions and operation of the machine.

## Pre-Operation Check List

- A. Check that all fittings are securely tight.
- B. Check electrical hook-up (qualified electrician recommended).
- C. Main power switch on Control Box should be switched to OFF position.

## WARNING

Do not place any part of the body in the path of the material spray.

Do not point the gun at or near other personnel.

Do not look into the Mixing Chamber orifice at any time.

Because of the hazardous materials used in this equipment, it is recommended that the operator use an air mask, goggles, protective clothing, and other safety equipment as prescribed by current regulations, recommendations of the chemical suppliers, and the laws in the area where the equipment is being used.

## Initial Start-Up Procedure

With all material and air lines connected and power cable attached, the system is now ready for start-up.

## Filling The System

1. The system is now ready to be filled with material. With transfer pumps in place, adjust regulators on transfer pumps to 30-50 psi or until the pumps begin cycling, once the pumps begin loading up (cycle rate slows or stops) increase transfer pump air pressure to 100 psi. to fill the system.

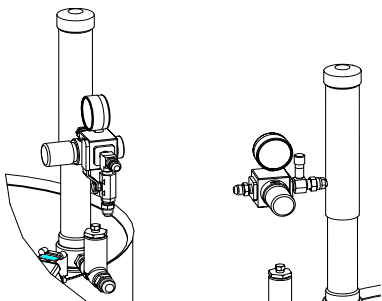

If the transfer pumps can not move material adequately enough to properly prime the system it may be necessary to start the hydraulic power pack.

- a. Ensure hydraulic pressure knob is turned completely **counter clockwise**.

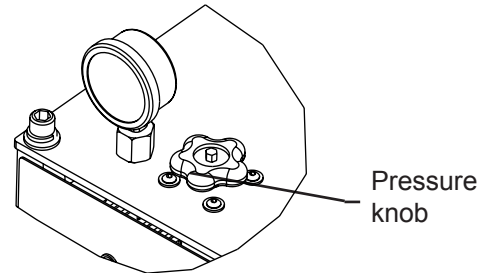

- b. Main air should be on to system manifold.

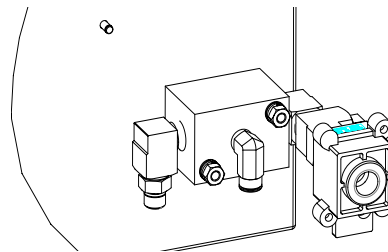

- c. Turn on hydraulic power pack.

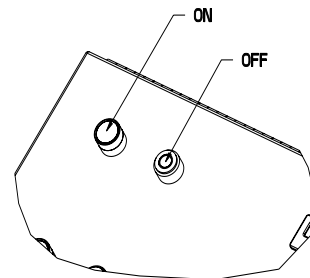

- d. Flip retract switch to "run" position.

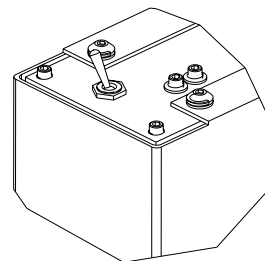

The pumps will begin cycling to completely prime the system

## Operation

2. Remove ISO & POLY side blocks from gun.  
**MAKE SURE VALVES ARE OFF!**

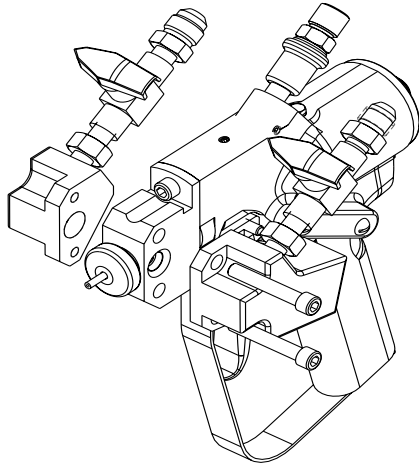

### PROBLER

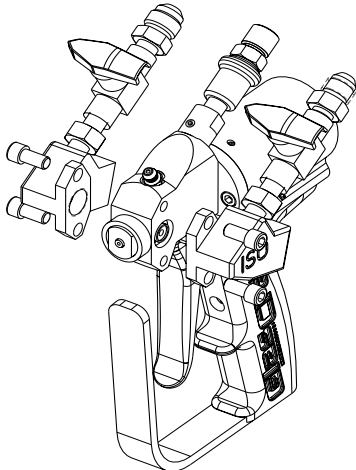

### PROBLER P2

3. Place separate clean containers under each individual side block. Slowly open material valves (black arrow forward) on each side block to allow trapped air to escape the hose and material to flow into the containers until all air is purged from the material system.

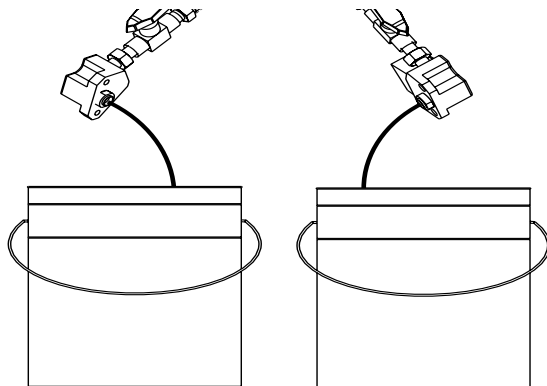

### NOTE

Remember to dispense one to two gallons of material to clear the system of grease and plasticizer that was used during factory testing.

4. Close manual material valves. Material pressure gauges should now register approximately equal pressure.
5. Dispose of waste material properly and in accordance with chemical suppliers instructions and local, state and federal regulations.

### NOTE

Before re-assembling Side Blocks, lubrication can be applied by dabbing a white lithium grease into holes inside of Gun Front Housing and wiping grease over Side-Block Seals. Grease will purge itself when air valve is turned on at Gun and Gun is triggered.

6. Clean and lubricate Side Blocks and Seals thoroughly and re-assemble on Gun. Make certain that Side Block Screws are tighten securely.
7. Refer to material manufacturers operating instructions for proper preparation of material, i.e, mixers, etc.
8. Turn main power Switch to ON position.

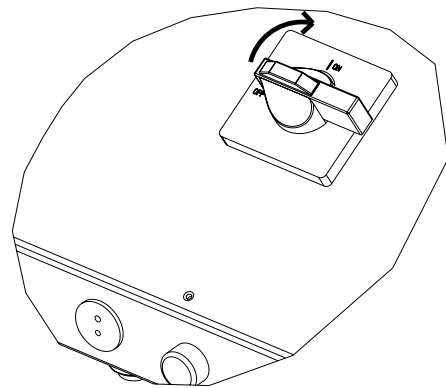

# Operation

9. Turn on hose control:
- Push in the green button.
  - Press either up or down arrow buttons on the controller until desired temperature setting is achieved.

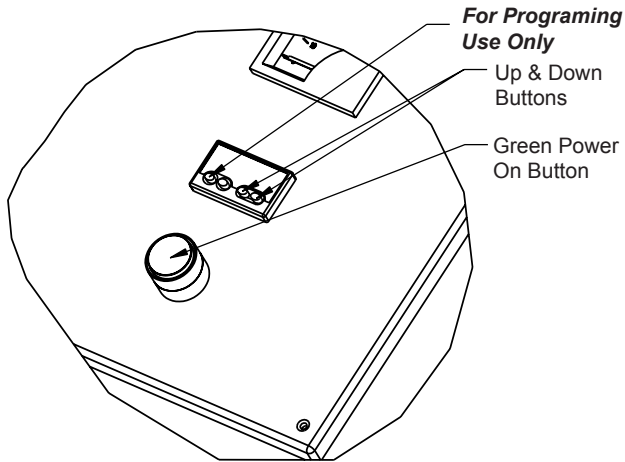

10. Turn on the ISO & POLY Heaters.

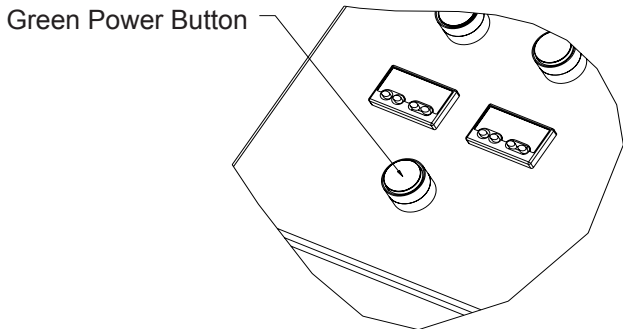

### NOTE

Turn transfer pump air regulator on slowly. Pumps should cycle slowly until hoses are full of material.

### WARNING

Straighten hose out flat, to avoid uneven heating and damage to internal wiring of the hose assembly.

11. Turn on Hydraulic Power Pack

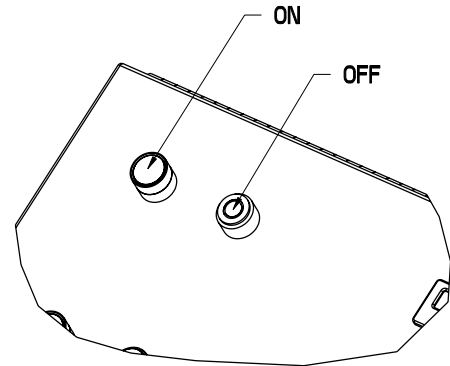

### NOTE

Allow enough time for hose to warm up (approximately 30 minutes). Remember that the heated hose does not have a delta rating. The heated hose's function is to maintain the heat generated by the primary heaters during system operation, and preheat material during initial start-up. The hose should be set to maintain a temperature close to the set point of the primary heaters.

### NOTE

To see the actual temperature of the liquid in the hose, push the blue button once and release. The actual temperature will then be displayed for 10 seconds.

12. Adjust temperature to desired setting. ISO and POLY controllers function exactly the same as the hose controller.

### NOTE

Allow enough time for the material to be heated (approximately 3-5 minutes).

13. Slowly adjust Hydraulic PRESSURE KNOB **clockwise** on the system to desired pressure.

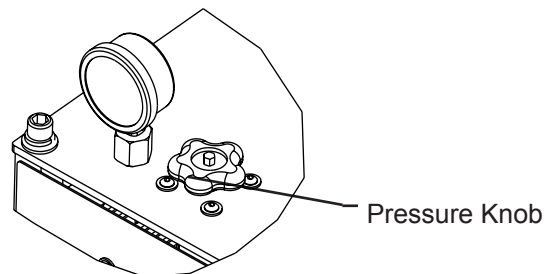

## Operation

14. Turn purge air and material valves ON at the gun.

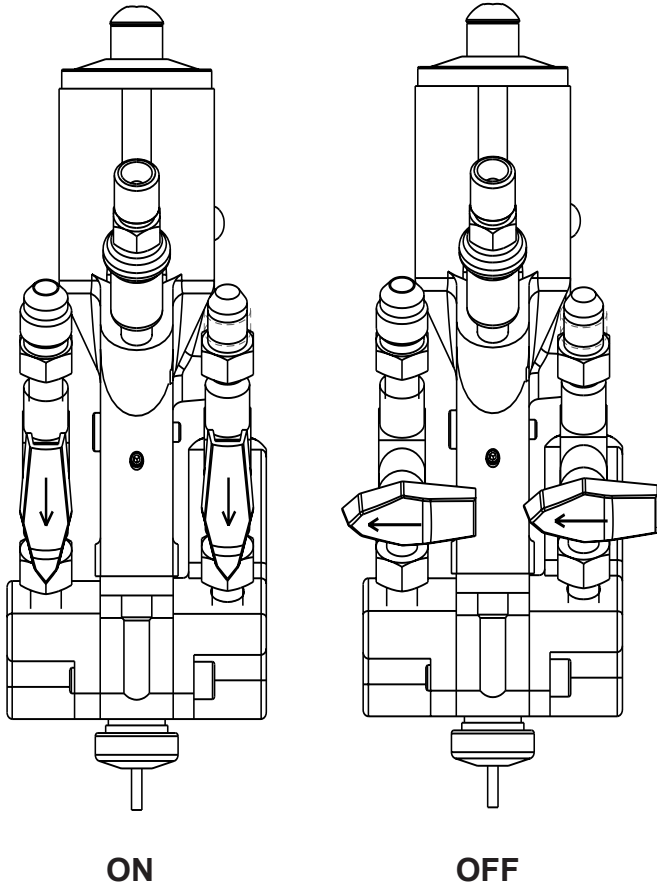

15. If one side registers considerably more pressure than the other side, go to the high pressure side and bleed off some pressure by slightly opening the manual material valve on the side block over the container. Bleed pressure until both sides are approximately the same pressure.

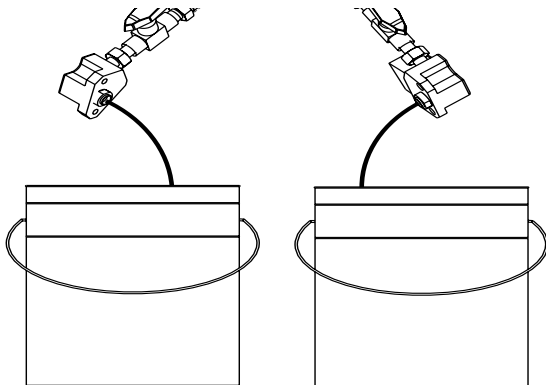

### WARNING

Material will dispense at high pressure. follow all safety precautions

16. Relieve any excess pressure by triggering the gun.

### NOTE

The Emergency Stop Switch is located on the top right side of the Box Panel, when depressed, it will shut down the power and activate the Air Dump Valve. To reset, turn handle on push button.

17. The system is now ready for operation.

### Over Pressure System Protection

The system incorporates monitors for high pressure monitoring. These monitoring devices will prevent the system from continued operation if high pressure situations develop.

There are pressure sensors located on each proportioning pump. The high pressure sensor is located at the outbound of the fluid section.

The high pressure monitoring sensor will engage if fluid pressure increases above 3200 psi.

If a high pressure situation develops, the sensor will detect this and immediately engage the hold-in circuit.

This will disengage power to the machine and it will stop cycling. It will also turn the heater off.

On the control box panel, there are two yellow lighted push buttons marked over pressure. One of these push buttons will be illuminated after the monitoring sensor engages, indicating where the problem is located (ISO or Poly).

Over Pressure Resets

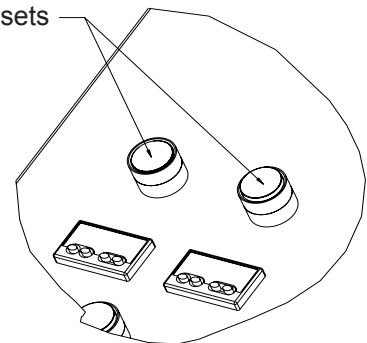

## Operation

In an over pressure situation, the system will remain shut down until it is manually reset.

At this point, it is necessary to determine if the problem is an over pressure situation.

When the sensor engages, the system will be frozen, giving you the pressure readings at the time the problem was detected.

Inspect the fluid pressure gauges, in an over pressure situation, one of the fluid pressure gauges will be significantly higher than the other gauge.

### WARNING

*When main power to unit is on, the console will have wires that are live. Disconnect or turn off main power source before opening console to make any repairs.*

### WARNING

*Before performing any repairs on the system, ALL AIR and FLUID PRESSURES SHOULD BE RELIEVED TO ZERO (BLEED-OFF)!*

### Over Pressure Problem Correction

1. Determine if the problem is high pressure related.
2. Relieve system hydraulic pressure.
3. Turn off main power
4. Fix the problem area:
  - a. Potential high pressure causes:
    - Restriction
    - Overheating material in static position
    - ISO filter at gun
5. Re-start system for operation
6. Once the power has been turned off and problem solved, and the main power is turned on again, the over pressure lighted buttons will automatically be reset.

**NOTE:** For additional diagnostics refer to trouble shooting guide GC-1380

### CAUTION

*If you do not understand the electrical hook-up described above, consult your local GlasCraft distributor OR a qualified electrician.*

*It is recommended that a qualified, licensed electrician should install power to the supply disconnect.*

*You should always follow all local or national electrical codes.*

### CAUTION

*Disconnect power source BEFORE attempting any repairs or opening the Control Boxes. Access to internal parts is limited to qualified personnel ONLY!*

*Place Main Power Breaker in OFF position BEFORE disconnecting power cables. This equipment is not approved for use in hazardous locations as set forth in the National Electrical Code Article 500 and Sub-Part "S" of the OSHA Standards.*

### Fluid Sections

The wiper/lubrication cup at the top of each fluid section is designed to keep piston shaft clean and lubricate throat seal.

This special design requires very little maintenance.

Each week:

1. Wipe any residue from the mouth of the lubrication cup.
2. Add 1 teaspoon of a suitable lubricating solution.

# Operation

## System Shut-Down

1. Flip “retract” switch from “run” position.

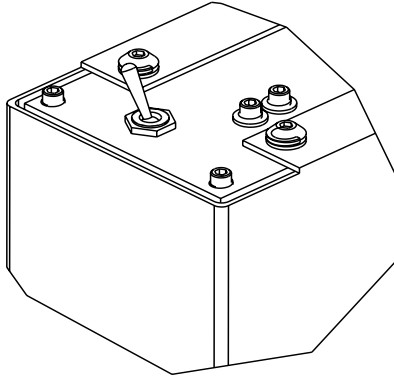

2. Trigger gun to send pumps into full downstroke.
3. Turn off hydraulic power pack.

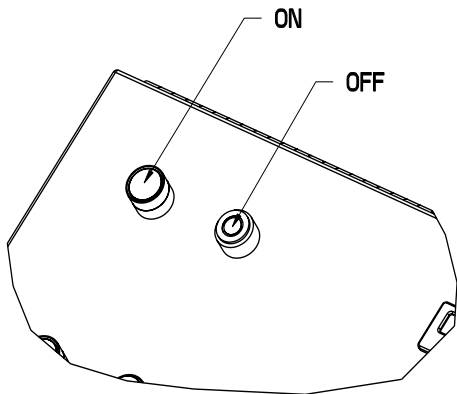

4. Turn off primary heaters.

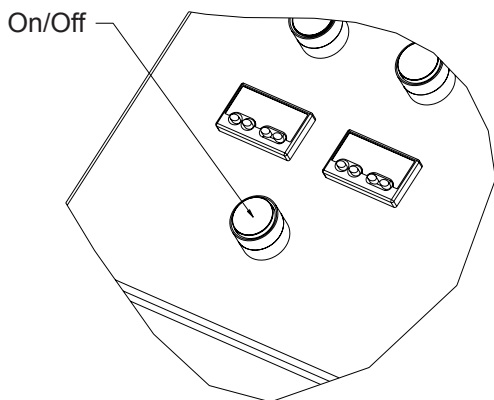

5. Turn main power switch off.

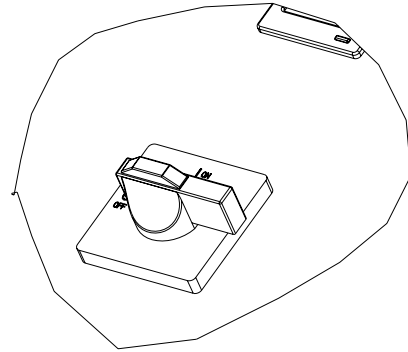

6. Refer to gun manual for proper Gun maintenance.
7. Reduce Hydraulic Pressure Knob setting to ZERO.
8. Visually inspect entire system for leaks.
9. Turn OFF System.

### CAUTION

*Do not bleed fluid pressure from the system.*

## Storing The Hose

Coil the hose with a minimum diameter of 4', To avoid kinking and subsequent damage to the internal wiring of the hose assembly.

# Operation

## System Daily Start-Up

1. Uncoil hose.
2. Check desiccant dryer beads to insure they are still purple and have not changed to pink.
3. Check and lube top of the fluid section.

Wipe off residual material and add a tablespoon of DOP or material suppliers recommended lubricant.

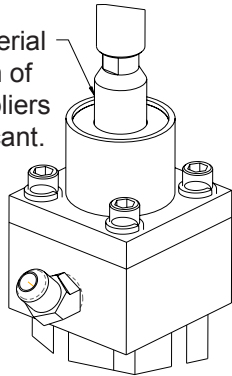

4. Check material screens at the gun and transfer pumps.
5. Start the drum mixer and it run to material suppliers specifications. (20-30 minutes)
6. Turn on the hose controller and set the temperature according to material suppliers specifications.

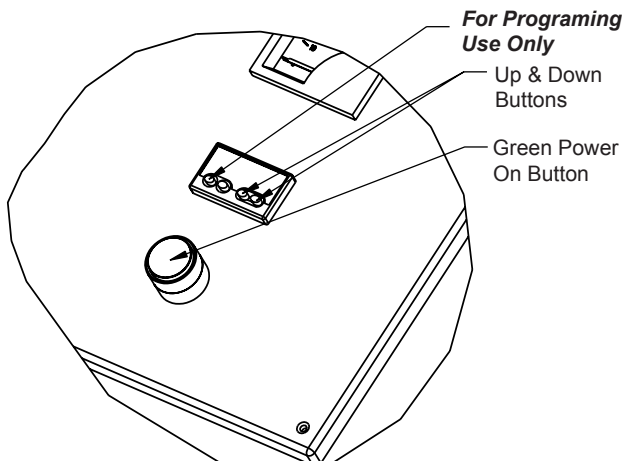

7. Once the hose temperature reaches 120°, It's ok to turn on the primary heaters and set temperature to material suppliers specifications.

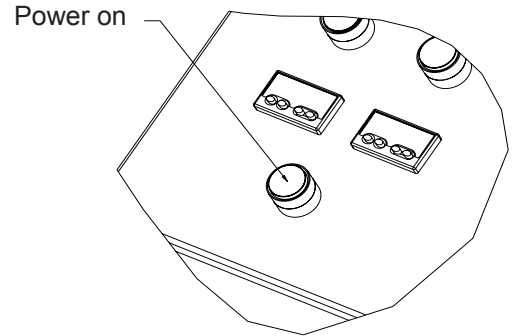

8. Depress yellow slide valve to open main air to gun and transfer pumps.

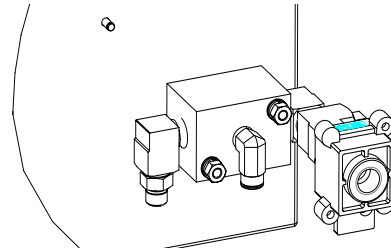

9. Flip retract switch to "run"

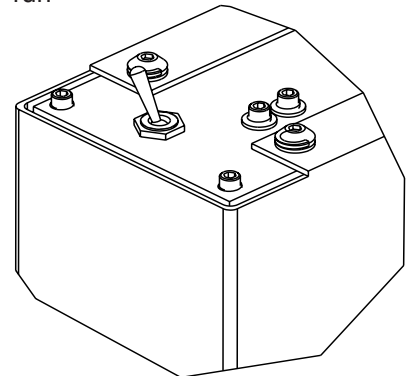

## Operation

### System Daily Start-Up

10. Increase Hydraulic pressure to desired pressure.

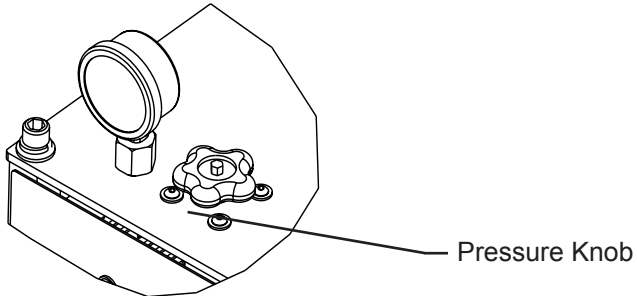

11. Perform Probler / Probler P2 side block seal integrity test.
12. Perform Probler / Probler P2 high-pressure ball valve test.
13. **READY TO SPRAY!**

## Limited Warranty Policy

GLASCRAFT, INC. ("GlasCraft") warrants to the original Purchaser of GlasCraft manufactured equipment and parts, that all GlasCraft manufactured equipment and parts will conform to their published written specifications and be free of defects in workmanship and material for a period of one (1) year from the original date of installation. GlasCraft makes no warranty to anyone other than the original Purchaser.

If any GlasCraft manufactured part or equipment is found to be defective in workmanship or material within the one-year period from the date of installation, as determined solely by GlasCraft, GlasCraft, in its sole discretion, will either repair or replace the defective part or equipment at GlasCraft's cost, including freight charges both ways, or credit or refund the purchase price for the defective equipment or part.

A warranty claim will be honored only when:

1. GlasCraft has been informed, in writing, of any such defect in workmanship or material within ten (10) days after discovery by the original Purchaser;
2. An official of GlasCraft has issued a return authorization number; and
3. The claimed defective equipment or part has been returned to GlasCraft by the original Purchaser, freight prepaid (with proper return authorization number(s) attached), to: GlasCraft, Inc., 5845 West 82nd Street, Suite 102, Indianapolis, IN 46278, U.S.A.

This warranty shall not apply to any equipment or parts that have been altered or repaired by anyone other than GlasCraft or to defects or damage resulting from improper installation, misuse, negligence, accident, or use not specified by GlasCraft. This warranty shall not apply to any equipment where any parts or components were replaced by any parts or components not manufactured or supplied by GlasCraft. The decision by GlasCraft shall be conclusive and binding on Purchaser.

GlasCraft does not warrant that any equipment or parts sold to Purchaser meet or comply with any local, state, federal, or other jurisdiction's regulations or codes. GlasCraft does not warrant that any equipment or part sold to Purchaser, when used individually or in concert with any other part, equipment, device, component or process, does not infringe on any patent rights of any third party. GlasCraft only warrants that it has no specific knowledge of any such infringement.

GlasCraft makes no warranty as to any parts or equipment manufactured by others. Purchaser shall look solely and only to the manufacturer of such parts or equipment with respect to any warranty claims. GlasCraft hereby assigns to Purchaser the original manufacturer's warranties to all such equipment and parts, to the full extent permitted.

**THE AFORESAID WARRANTY IS IN LIEU OF ALL OTHER WARRANTIES, EXPRESS OR IMPLIED. SPECIFICALLY THERE ARE NO WARRANTIES OF MERCHANTABILITY OR FITNESS FOR A PARTICULAR PURPOSE, WHICH WARRANTIES ARE SPECIFICALLY DISCLAIMED.**

GlasCraft shall not be liable for any loss or expense resulting from damage or accidents caused by improper use or application of materials manufactured or sold by GlasCraft or its distributors or agents.

**UNDER NO CIRCUMSTANCES SHALL GLASCRAFT'S LIABILITY EXCEED THE AMOUNT PURCHASER PAID FOR THE CLAIMED DEFECTIVE EQUIPMENT OR PART. UNDER NO CIRCUMSTANCES SHALL GLASCRAFT BE LIABLE FOR INCIDENTAL OR CONSEQUENTIAL DAMAGES OR FOR LOST PROFITS.**

No action arising from or relating to any goods manufactured by or purchased from GlasCraft may be brought more than one (1) year after the cause of action accrues.









**If You Have An Equipment Problem.....**

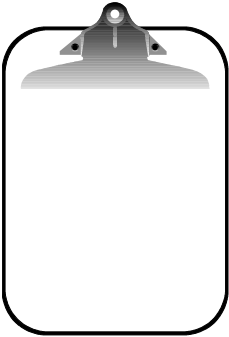

*If you have a problem that requires Distributor or GlasCraft Service Department help, gather the following information **BEFORE** you pick-up the telephone.*



	<b>Model No.</b>	<b>Serial No.</b>
SPRAY GUN		
MATERIAL PUMP		
TYPE OF MATERIAL BEING SPRAYED		
		%
SYSTEM GAUGE PRESSURES		
ISO HEATER GAUGE		PSI
POLY HEATER GAUGE		PSI
MATERIAL PUMP		PSI
MAIN AIR LINE PRESSURE AT SYSTEM		PSI
MAIN AIR LINE VOLUME		CFM
COMPRESSOR SIZE		HP
COMPRESSOR TO SYSTEM SUPPLY LINE SIZE		INCHES

*Have a general equipment or operation question?  
You can contact the GlasCraft Service Department via E-Mail at [service@glascraft.com](mailto:service@glascraft.com)*

**For Your Reference**

**DATE PURCHASED** \_\_\_\_\_  
**DISTRIBUTOR** \_\_\_\_\_  
\_\_\_\_\_  
\_\_\_\_\_  
**CONTACT** \_\_\_\_\_  
**PHONE** \_\_\_\_\_  
\_\_\_\_\_

*Manufacturers of ...  
Fiberglass Fabrication Systems with High Transfer Efficiency and Low Emissions,  
Systems for Low or High Production,  
and Systems to Improve Quality and Profitability*

**INDy Series**

*"Internal-Mix Non-Atomized Dispense Systems"  
... featuring INDy Nozzle Wet-Out, Chopper &  
Pressure-Fed Roller Systems and Equipment*

**APD**

ADHESIVE DISPENSING SYSTEM

**Micro II, Maxi II, Super Maxi,  
Mini III, MX, MX II, MH & MH II**  
*...featuring the patented Probler Spray/Pour Gun*

**Spartan**

RESIN TRANSFER MOLDING SYSTEM

SPRAY, POUR & INJECT  
FIXED & VARIABLE RATIO SYSTEMS and  
EQUIPMENT FOR POLYURETHANE FOAMS,  
COATINGS and POLYUREAS

For more information concerning any of these GlasCraft products,  
contact your local authorized GlasCraft distributor, or



A detailed technical line drawing of a GlasCraft dispensing system. The drawing shows a complex assembly of components including a central vertical column, various tanks, valves, and piping. Labels 'ISO' and 'POLY' are visible on the left side. The drawing is rendered in a light gray color, serving as a background for the text and logo.

Quality and Performance...

GENUINE GLASCRAFT

**Glas** **Craft**  
DISPENSING EXCELLENCE

**ADS**  
ADVANCED DISPENSE  
SYSTEMS

[www.glascraft.com](http://www.glascraft.com)

GC-1267  
REVISION P

5845 WEST 82nd STREET  
INDIANAPOLIS, INDIANA 46278  
U.S.A.

Phone (317) 875-5592  
Fax (317) 875-5456  
E-Mail [sales@glascraft.com](mailto:sales@glascraft.com)