

**Glas
craft**
DISPENSING EXCELLENCE

MH II

Dispensing System

INCLUDES:

17254-XX
PROBLER GUN
ASSEMBLY

19524-01
MANUAL HOSE
ASSEMBLY

18006-01
HEATED WHIP
ASSEMBLY

21835-00
1:1 PUMP
ASSEMBLY

22075-00
DUAL HEAT EXCHANGER
ASSEMBLY

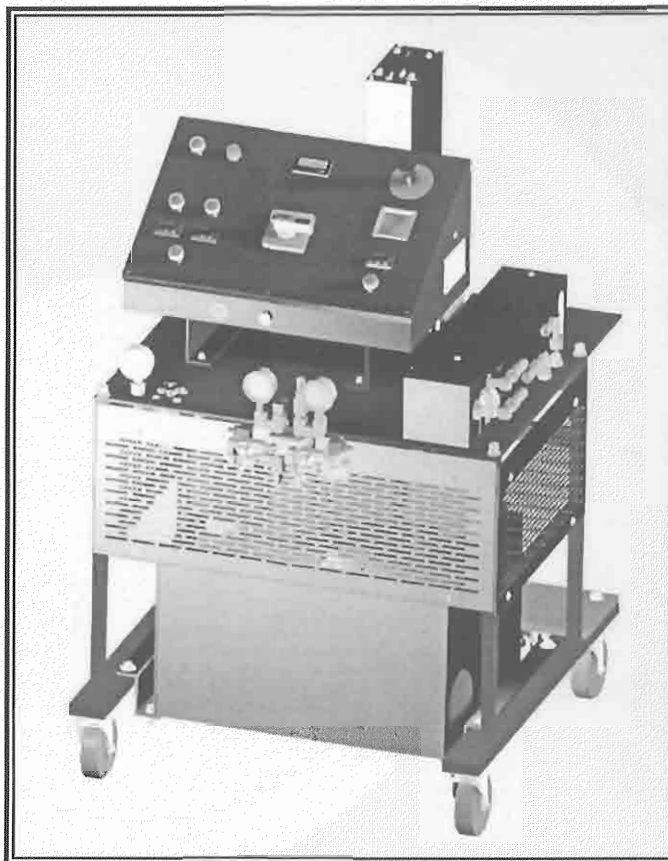

USER MANUAL

GlasCraft
DISPENSING EXCELLENCE

5845 WEST 82nd STREET
INDIANAPOLIS, INDIANA 46278 U.S.A.
Phone (317) 875-5592
Fax (317) 875-5456
E-Mail gcisales@glascraft.com
Web www.glascraft.com

CE
CERTIFIED



An ISO 9001
Approved
Company

CONTENTS

Introduction

ABOUT THIS MANUAL	1
RELATED MANUALS	1

Parts & Illustrations

MH II FOAM SYSTEM	2
OPTIONS	2
REPAIR PARTS KITS	2
SYSTEM SPECIFICATIONS	3
22850-XX MH II SYSTEM CONSOLE	4
22850-XX MH II SYSTEM CONSOLE	5
22850-XX MH II SYSTEM ASSEMBLY	6
22850-XX MH II SYSTEM ASSEMBLY	7
22850-XX MH II SYSTEM ASSEMBLY	8
22850-XX MH II SYSTEM ASSEMBLY	9
22850-XX MH II SYSTEM ASSEMBLY	10
22850-XX MH II SYSTEM ASSEMBLY	11
22850-XX MH II ASSEMBLY	12
22852-XX MH II CONTROL BOX ASSEMBLY	13
22852-XX MH II CONTROL BOX ASSEMBLY	14
22852-XX MH II CONTROL BOX ASSEMBLY	15
22852-XX MH II CONTROL BOX ASSEMBLY	16
22852-XX MH II CONTROL BOX ASSEMBLY	17
22852-XX MH II SCHEMATIC	18
22852-XX MH II SCHEMATIC VARIATIONS	19
21835-00 FLUID SECTION ASSEMBLY	20
22075-00 DUAL HEAT EXCHANGER ASSEMBLY	21
19524-01 MANUAL HOSE ASSEMBLY	22
18006-01 HEATED WHIP HOSE	23
TYPICAL SYSTEM CONN. FOR 50 FT. APPLICATIONS	24
TYPICAL MATERIAL FLOW SCHEMATIC FOR 50 FT.	25
TYPICAL SYSTEM CONN. FOR 100-300 FT.	26
TYPICAL MATERIAL FLOW SCHEMATIC FOR 100-300 FT. APPLICATIONS	27
17254-XX PROBLER SPRAY GUN	28

Safety

URETHANE SAFE HANDLING AND USE OF FOAM EQUIPMENT	29
--	----

Installation

ASSEMBLY INSTRUCTIONS	32
INSTRUCTIONS FOR HOSES	32
OPTIONAL TRANSFER PUMP INSTALLATION	33
OPTIONAL AIR DRYER KIT	33
ELECTRICAL CONNECTIONS	33
HYDRAULIC PACK	34

Operation

PRE-OPERATION CHECKLIST	35
INITIAL START-UP PROCEDURE	35
FILLING THE SYSTEM	35
OVER PRESSURE SYSTEM PROTECTION	37
OVER PRESSURE PROBLEM CORRECTION	37
FLUID SECTIONS	37
SYSTEM SHUTDOWN	37

Overhaul Procedure

BREAKING DOWN PUMP	39
DISASSEMBLE SUB-ASSEMBLIES	39
CLEANING	40
INSPECTION	40
FOR 19875-00 PUMPS	40

Limited Warranty Policy

42

Notes

43

If You Have An Equipment Problem

44

For Your Reference

INSIDE BACK COVER

INTRODUCTION

About This Manual

Before operating, maintaining or servicing any **Glas-Craft** system, read and understand all of the technical and safety literature provided with **Glas-Craft** products. If you do not have the manuals and safety literature for your **Glas-Craft** system, contact your **Glas-Craft** distributor or **Glas-Craft, Inc.**

In this **Glas-Craft** technical and safety publication, the following advisories will be provided where appropriate:

NOTE

Is information about the procedure in progress

CAUTION

Is imperative information about equipment protection.

WARNING

Is imperative information about equipment protection.

The information in this document is intended only to indicate the components and their normal working relationship typical use. Each assembly should be directed by a **Glas-Craft** distributor or made from the **Glas-Craft** assembly instructions provided.

This manual provides information for the assembly, operation, maintenance and service of this **Glas-Craft** product as used in a typical configuration. While it lists standard specifications and procedures, some deviations may be found.

In order to provide our users with the most up-to-date technology possible, we are constantly seeking to improve products. If technological change occurs after a product is on the market, we will implement that technology in future production and, if practical, make it available to current users as a retrofit, up-date or supplement. If you find some discrepancy between your unit and the available documentation, contact your **Glas-Craft** distributor to resolve the difference. **Glas-Craft, Inc.** reserves the right to change or modify this product as it deems necessary.

Careful study and continued use of this manual will provide a better understanding of the equipment and process, resulting in more efficient operation, longer trouble-free service and faster, easier trouble-shooting.

Related Manuals

For detailed component installation, operation and maintenance, refer to the following component manuals:

	COMPONENT	MANUAL NUMBER
17254	Probler Gun	GC-1023

PARTS & ILLUSTRATIONS

MH II Dispensing System

25lbs.(12kg.)/min. Spray or Pour Dispensing System

INCLUDES

22850-XX	MH II FOAM SYSTEM
17254-XX	PROBLER GUN ASSEMBLY
	• W/ ROUND SPRAY MIXING CHAMBER
18006-01	HEATED WHIP HOSE ASSEMBLY
19524-01	MANUAL HEATED HOSE ASSEMBLY
22852-XX	ELECTRICAL CONTROL ASSEMBLY
	OVERPRESSURE PROTECTION DEVICES
22145-05-XX	HYDRAULIC UNIT ASSEMBLY
21835-00	FLUID SECTION ASSEMBLY 1.5:1
22075-00	DUAL HEAT EXCHANGER ASSEMBLY
59934-04	DIOCTYL PHTHALATE, 1 QT.
17661-03	GUN SERVICE KIT
	HOSE THERMOMETER
19507-03	AIR HOSE ASSEMBLY
	MIXING CHAMBER REMOVAL TOOL
	USER MANUALS

OPTIONS

22023-01	MANUAL HIGH PRESSURE HOSE ASSY., 50 FT.
19524-01	MANUAL MEDIUM PRESSURE HOSE ASSY., 50 FT.

RECOMMENDED SERVICE KITS

19134-00	GUN REPAIR KIT
21063-00	HEAT EXCHANGER KIT
21845-00	PUMP FLUID SECTION REPAIR KIT
	HYDRAULIC FLUID PUMP

SYSTEM SPECIFICATIONS

MATERIAL RATIO:	1:1 (FIXED)
MATERIAL VISCOSITY:	200- 2000 CENTIPOISE (CPS) AT OPERATING TEMPERATURES
OUTPUT:	25 POUNDS PER MINUTE 12 KILOGRAMS PER MINUTE .042 GAL/CYCLE
OPERATING TEMPERATURES:	32° F (0° C) - 190° (88 ° C)
OPERATING PSI:	3000 PSI. MAX (OVER PSI SWITCHES SET)
HOSES:	2200 PSI. W/19524-00 2600 PSI. W/ 22024-00
HYDRAULIC PSI TO PUMPS:	2:1 RATIO
PURGING:	AUTOMATIC PNEUMATIC, SOLVENT-FREE, CONSTANT
ELECTRICAL REQUIREMENTS:	74 AMPS @ 208/240 VAC, 50/60 HZ Single Phase 5 HP 35 AMPS @ 208/240 VAC, 50/60 HZ Three Phase 5 HP 27 AMPS @ 380 VAC, 50 HZ Three Phase 5 HP
COMPRESSED AIR REQUIREMENTS:	15 CFM @ 100 PSI 425 LITERS @ 6.8 BAR
MAX HOSE LENGTH:	310' X 3/8 I.D. HOSE INCLUDES 10' X 1/4 I.D. HEATED WHIP HOSE
OVERALL DIMENSIONS:	IN WIDE IN LENGTH IN HIGH
SHIPPING WEIGHT:	950 LBS

22850-XX MH II SYSTEM CONSOLE

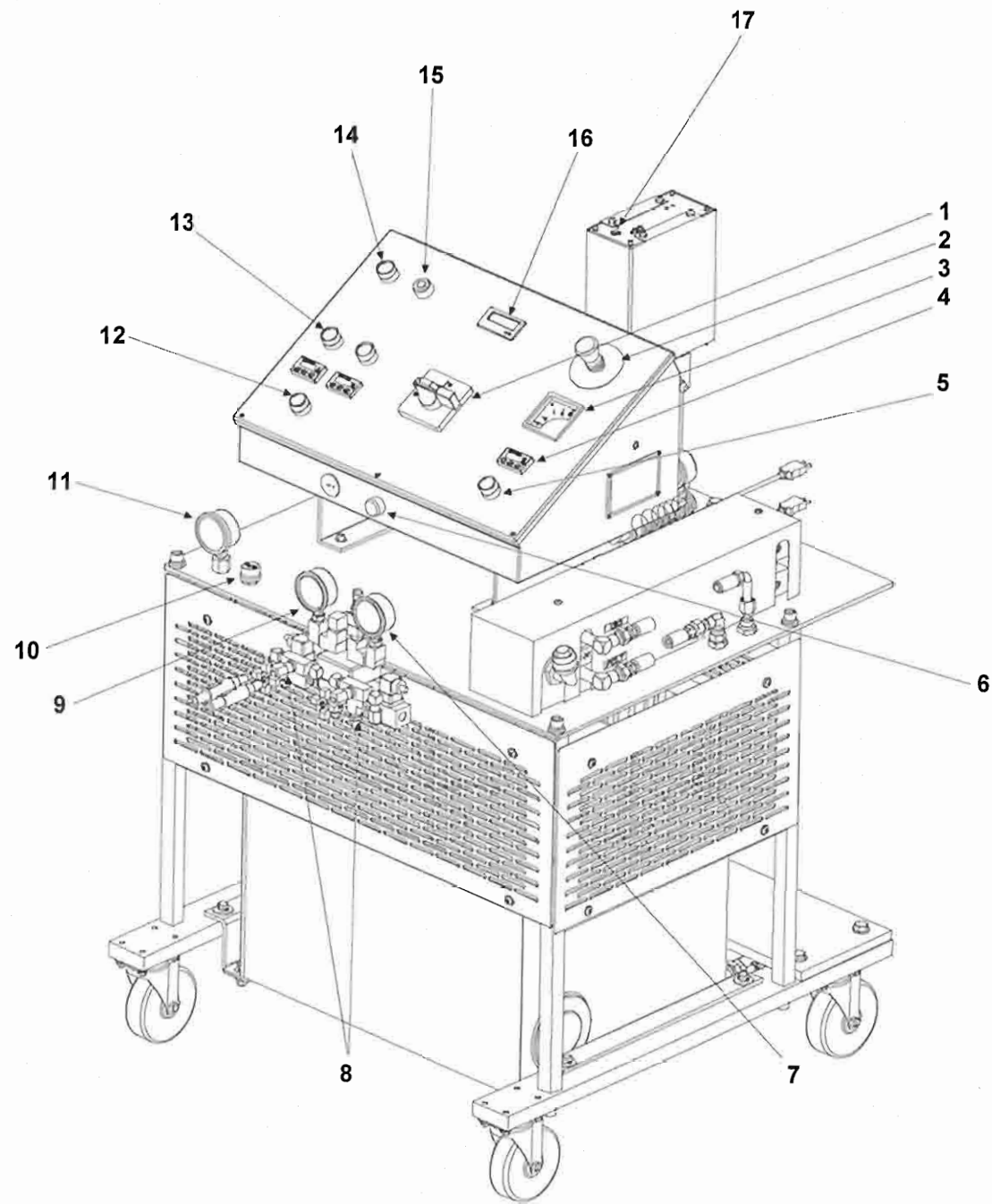

22850-XX MH II CONSOLE

1	DOOR INTERLOCK	<input checked="" type="checkbox"/> Controls power and door; handle must point 1 to energize power , handle must point to 0 to open control box door. White pilot indicates when lighted, that the door interlock and power is on.
2	EMERGENCY STOP PUSH BUTTON	<input checked="" type="checkbox"/> To stop all functions, push down on red button. To reset, turn handle on push button. All functions will remain off. All functions must be reset individually.
3	AMMETER	<input checked="" type="checkbox"/> An instrument for measuring amperes to the primary side of the hose's transformer.
4	HOSE CIRCUIT CONTROLLER	<input checked="" type="checkbox"/> .Controls hose temperature. Operator is to set. Temperature is regulated by Thermocouple in the hose.
5	ON PUSH BUTTON	<input checked="" type="checkbox"/> Indicates power is on to the hose.
6	WHITE PILOT LIGHT	<input checked="" type="checkbox"/> Indicates power on.
7	POLY PRESSURE GAUGE	<input checked="" type="checkbox"/> Indicates material pressure.
8	OVER PRESSURE SWITCHES	<input checked="" type="checkbox"/> (Over Pressure Switch/Sensor) Shuts down Primary Heaters and Hydraulic Pack when Set Point PSI is exceeded.
9	ISO PRESSURE GAUGE	<input checked="" type="checkbox"/> Indicates material pressure.
10	HYDRAULIC PRESSURE KNOB	<input checked="" type="checkbox"/> Increases or decreases hydraulic pressure. Turn clockwise to increase pressure. Turn counter-clockwise to decrease pressure.
11	HYDRAULIC PRESSURE GAUGE	<input checked="" type="checkbox"/> Indicates hydraulic pump pressure.
12	ON PUSH BUTTON	<input checked="" type="checkbox"/> Powers the controllers. It requires 10 seconds for the controllers to respond.
13	OVER-PRESSURE RESET BUTTONS	<input checked="" type="checkbox"/> When over-pressure is detected, the hydraulic power pack and primary heaters will be shut down, and will remain off until pressure is reduced and the push button is reset. (ALL COMPONENTS MUST BE RE POWERED.)
14	ON PUSH BUTTON	<input checked="" type="checkbox"/> Powers the hydraulic pwer pack.
15	OFF PUSH BUTTON	<input checked="" type="checkbox"/> Removes power to the hydraulic power pack.
16	COUNTER	<input checked="" type="checkbox"/> Counts pumps cycles. (.042x pump cycles = us gallons) (.238x pump cycles= liters)
17	RETRACT SWITCH	<input checked="" type="checkbox"/> At the end of operation, position switch to "RETRACT" ,Bleed PSI until pumps stall in full Down Stroke, before shutting off system.

22850-XX MH II SYSTEM ASSEMBLY

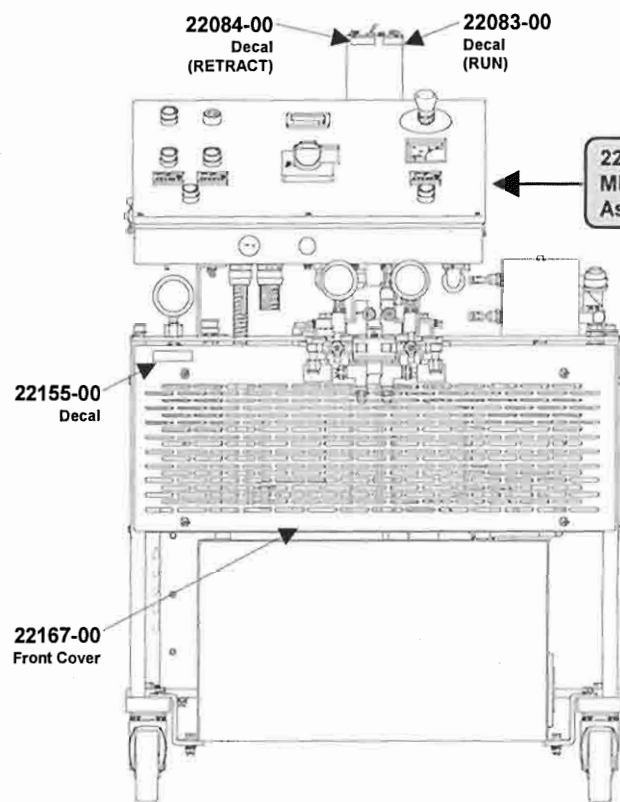

Front View

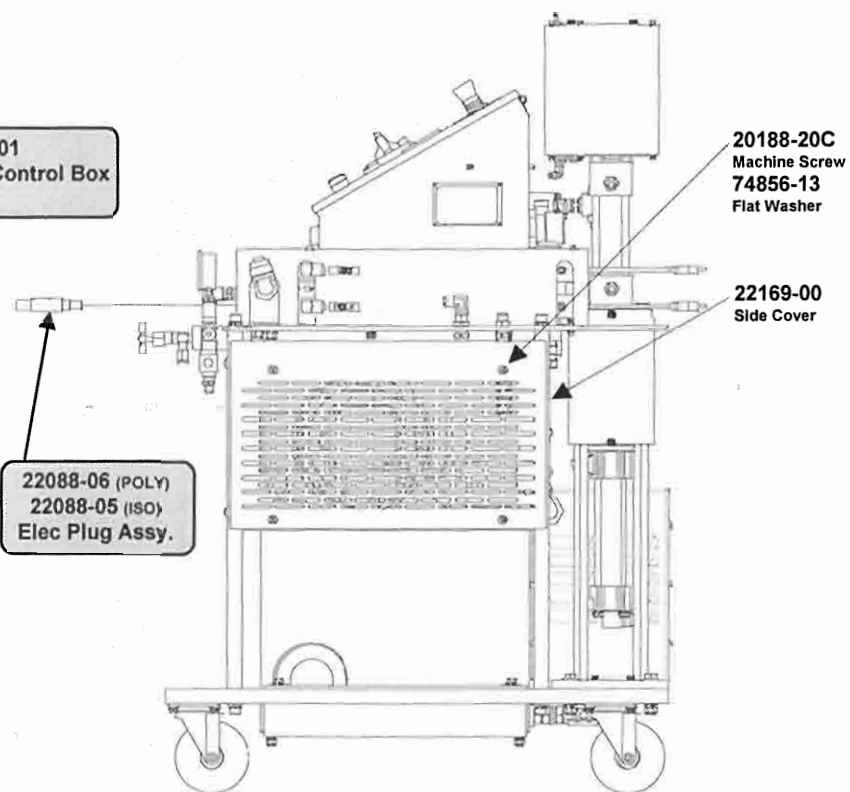

Right Side View

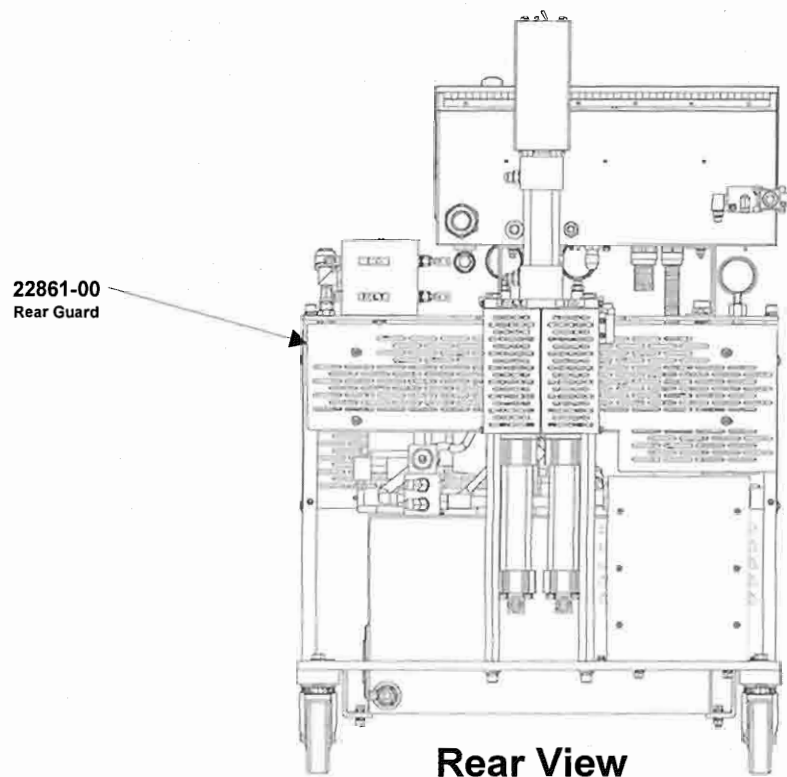

Rear View

REVISED 5/04

22850-XX MH II ASSEMBLY

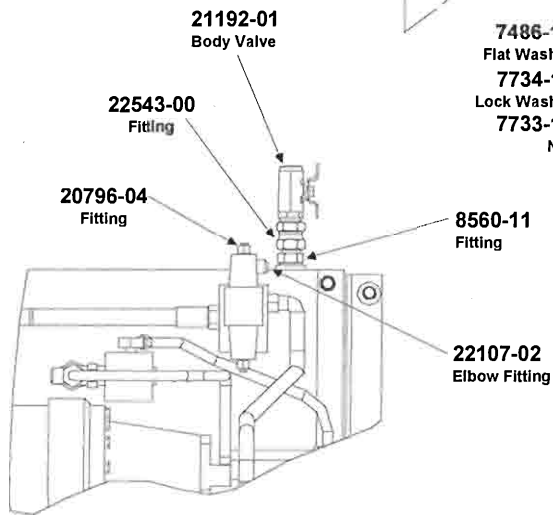
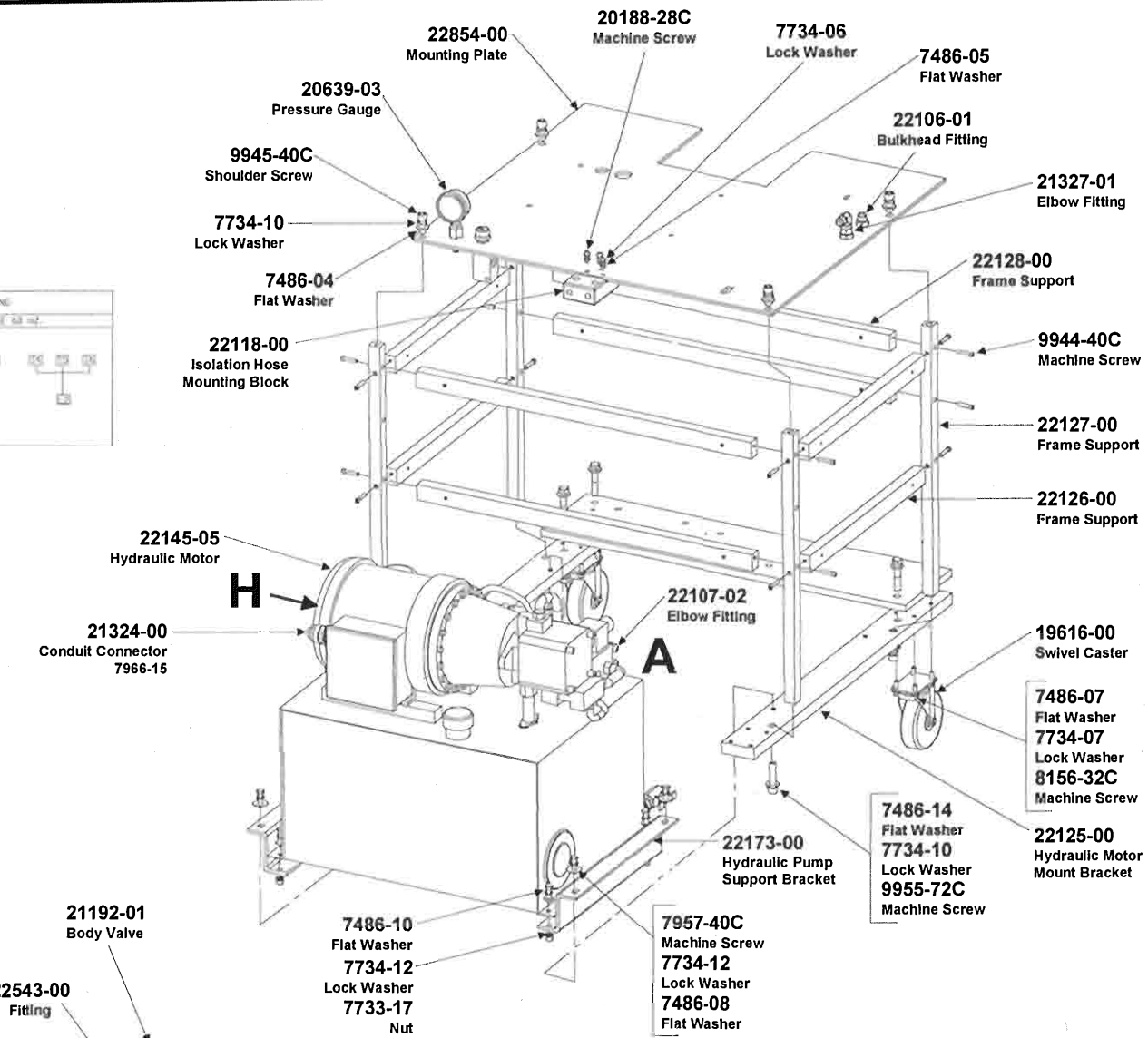
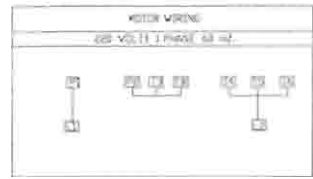

View A

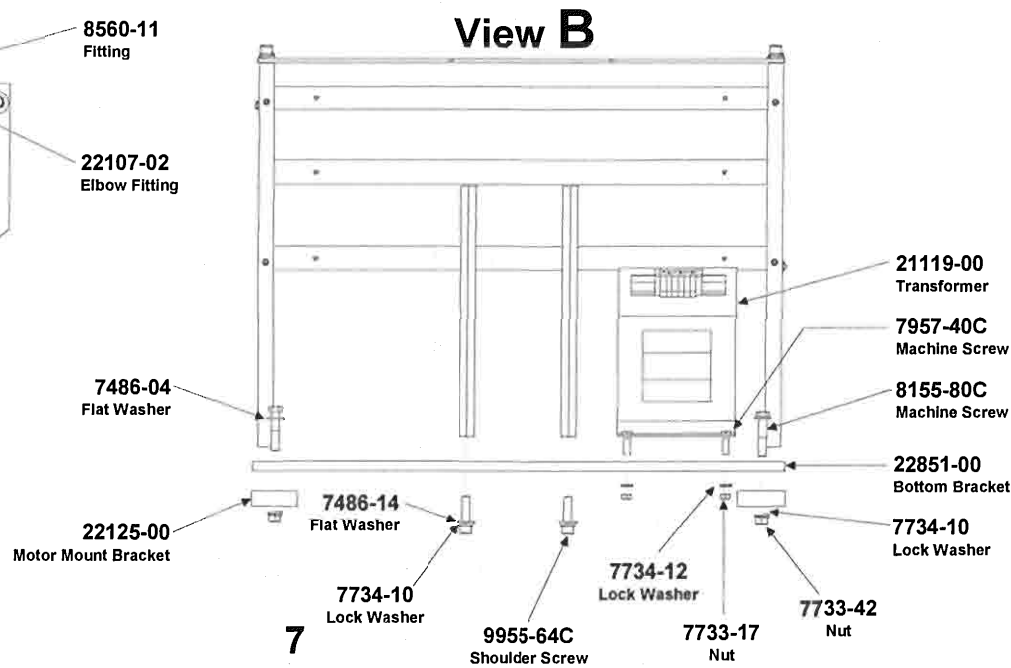

22850-XX MH II ASSEMBLY

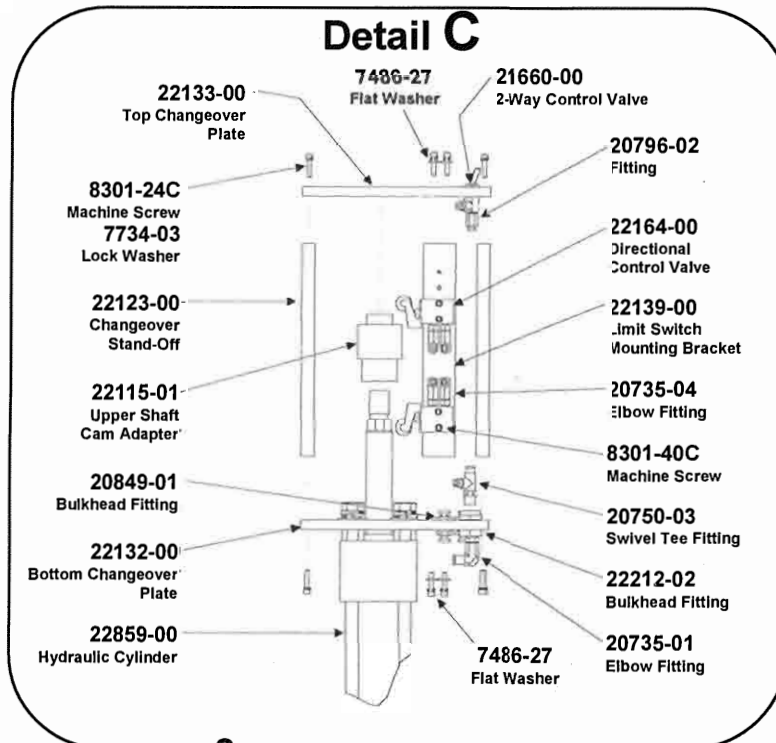
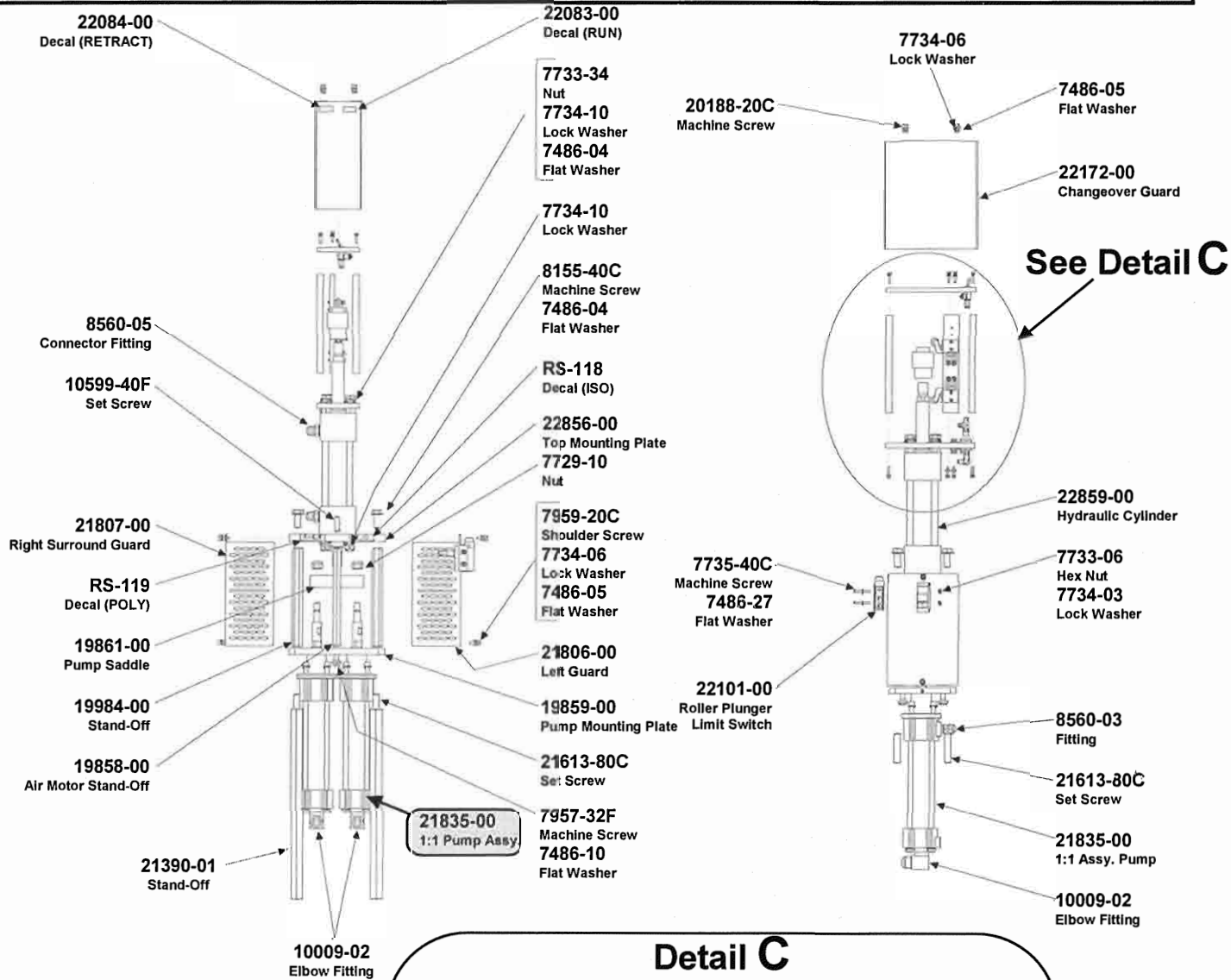

22850-XX MH II SYSTEM ASSEMBLY

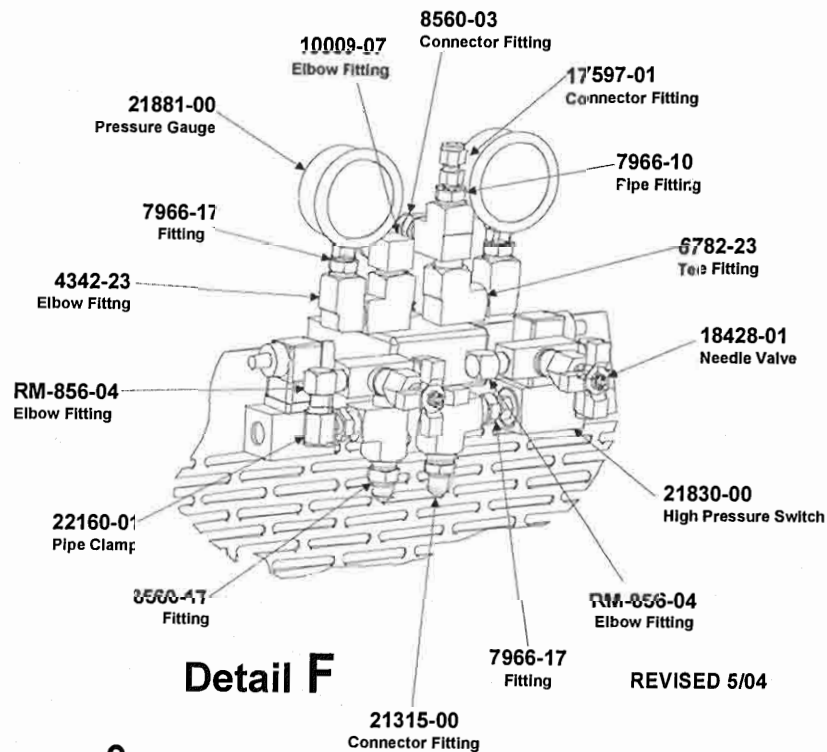
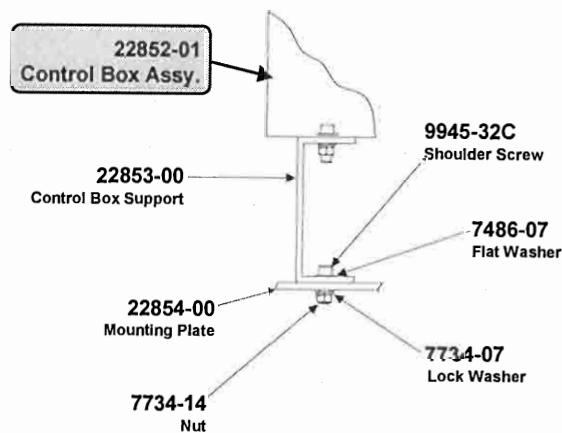
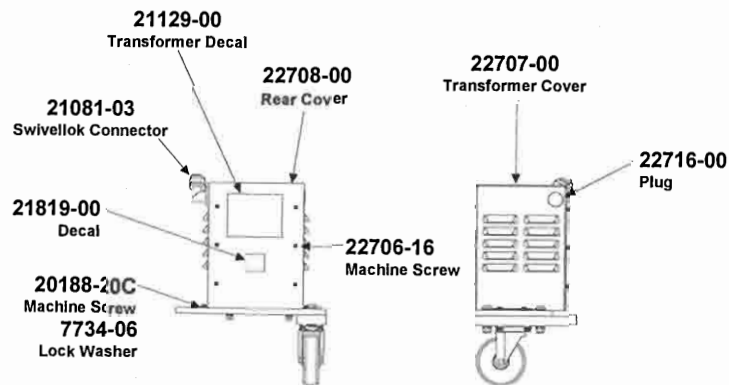
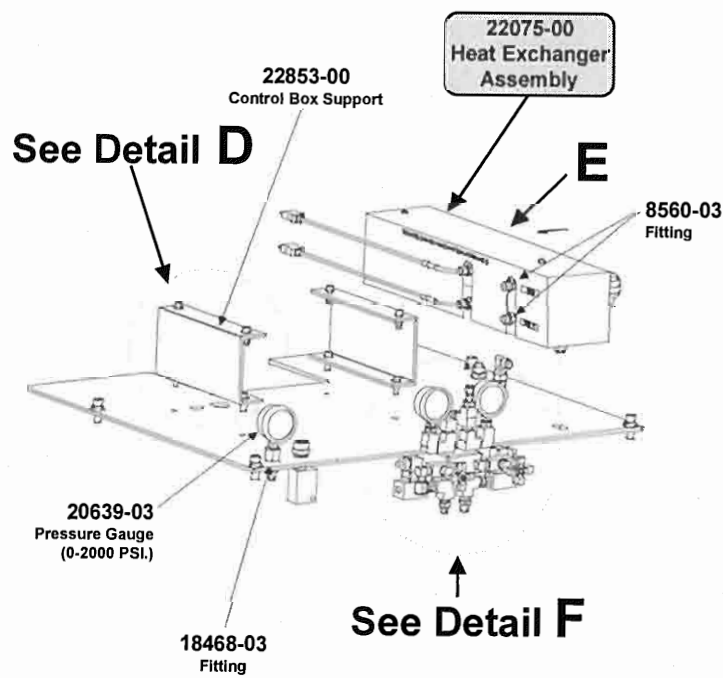
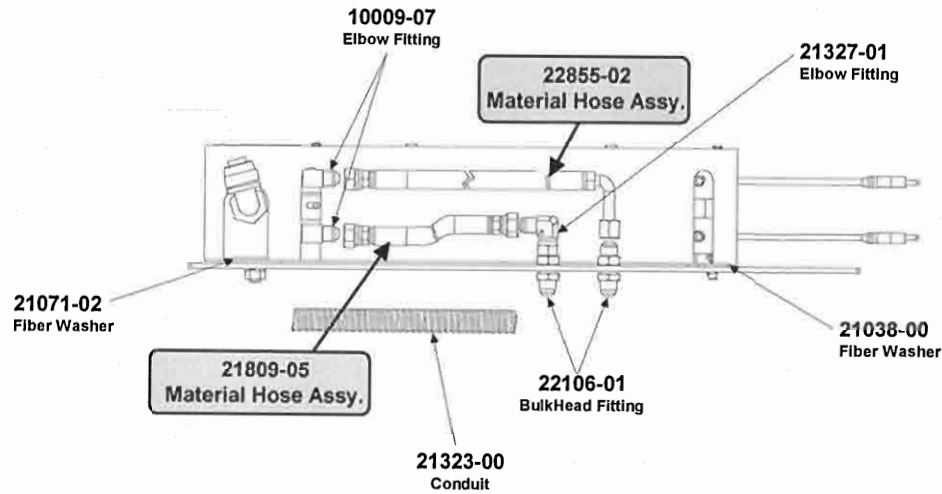

Detail D

Detail F

REVISED 5/04

22850-XX MH II ASSEMBLY

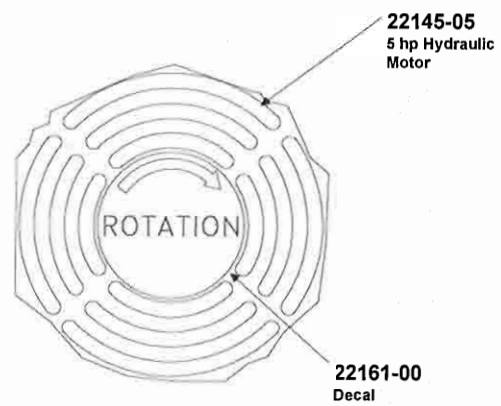
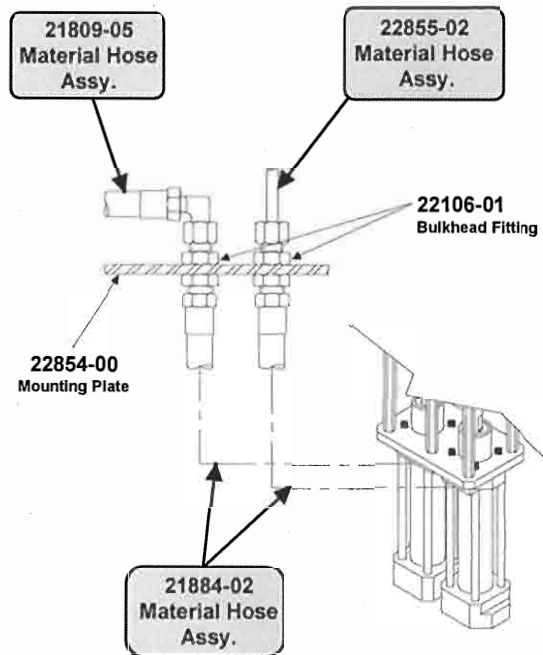

Detail H

22850-XX MH II ASSEMBLY

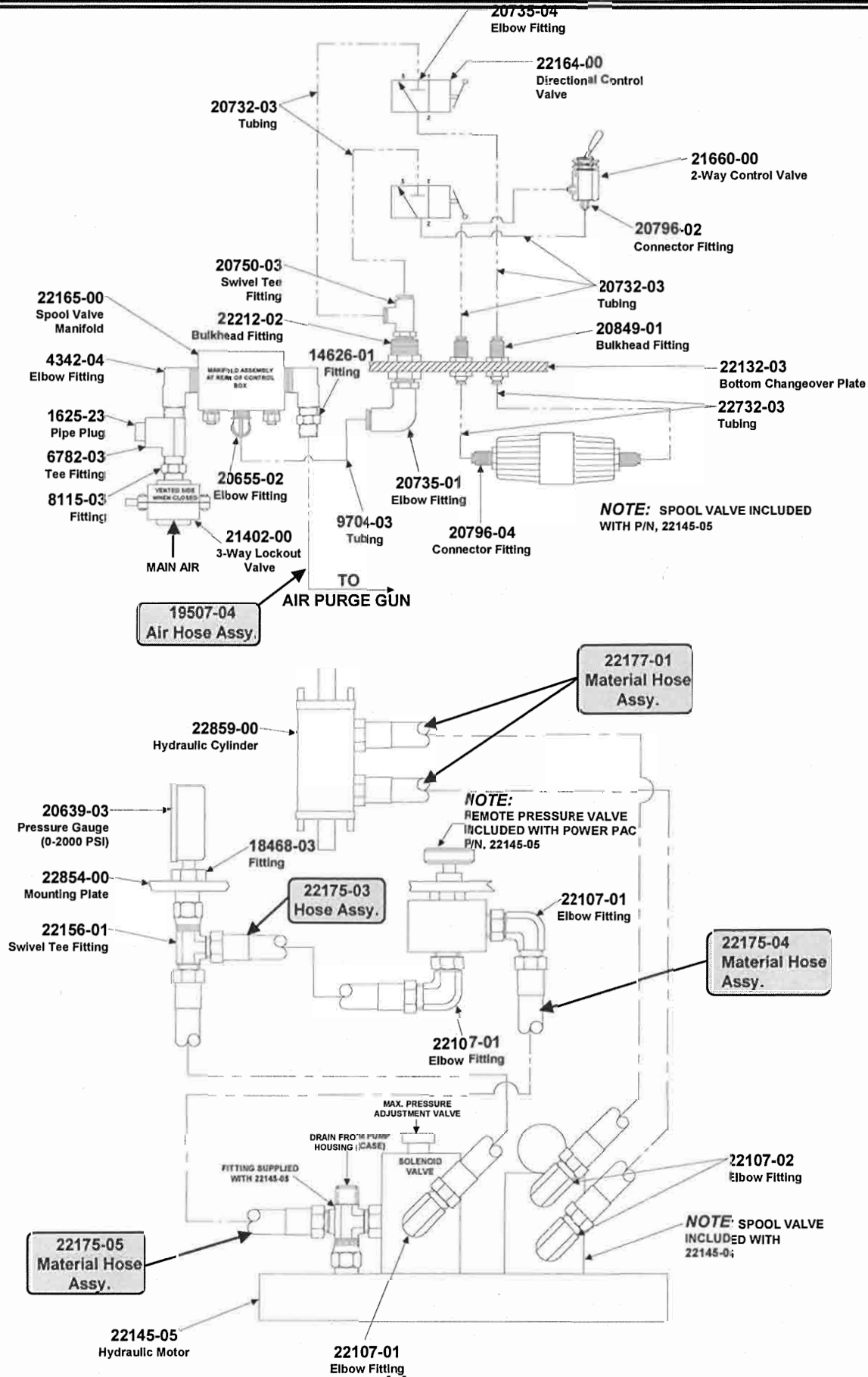

22850-XX MH II ASSEMBLY

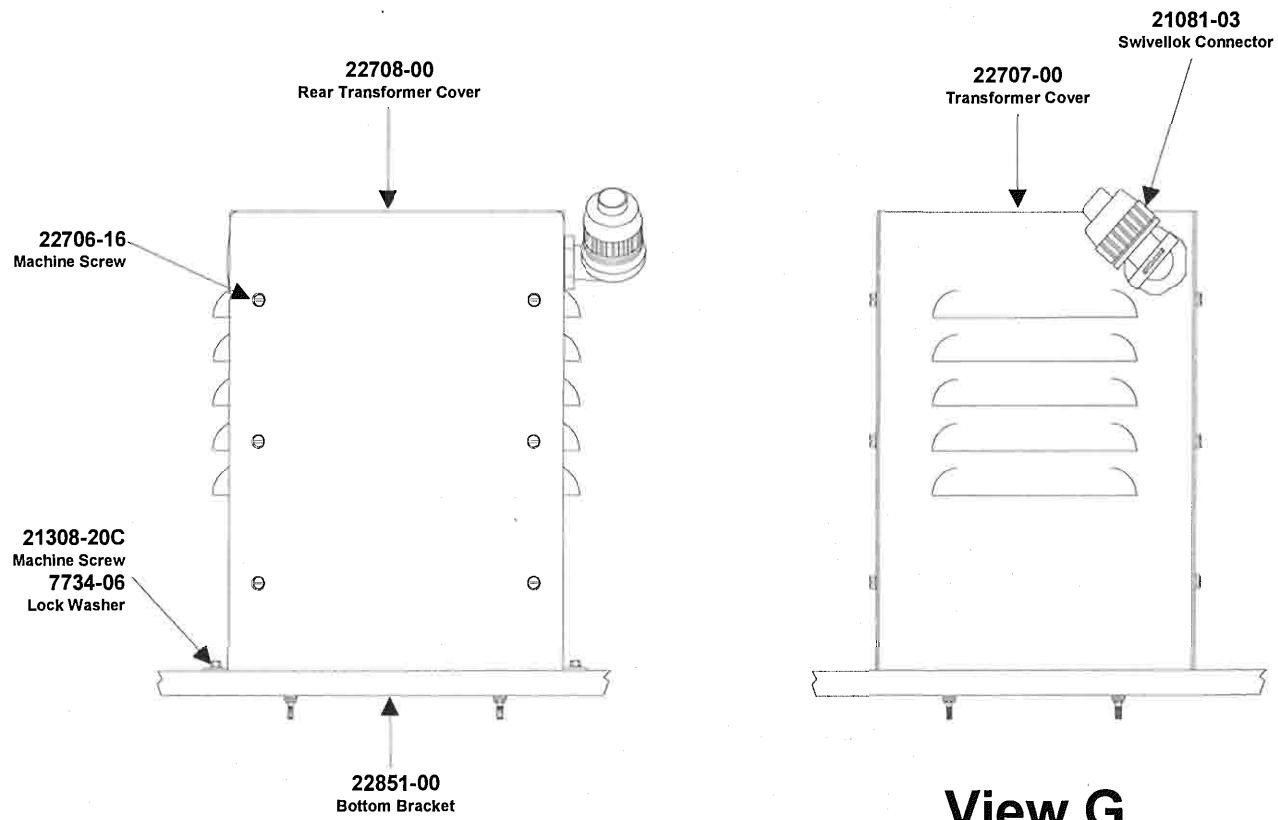
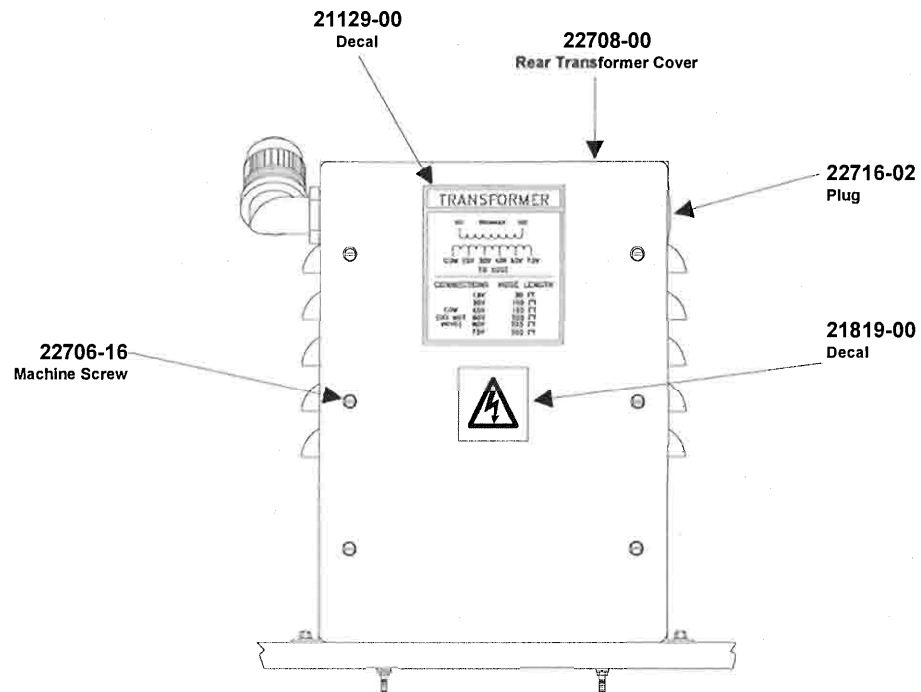

22852-XX MH II CONTROL BOX ASSEMBLY

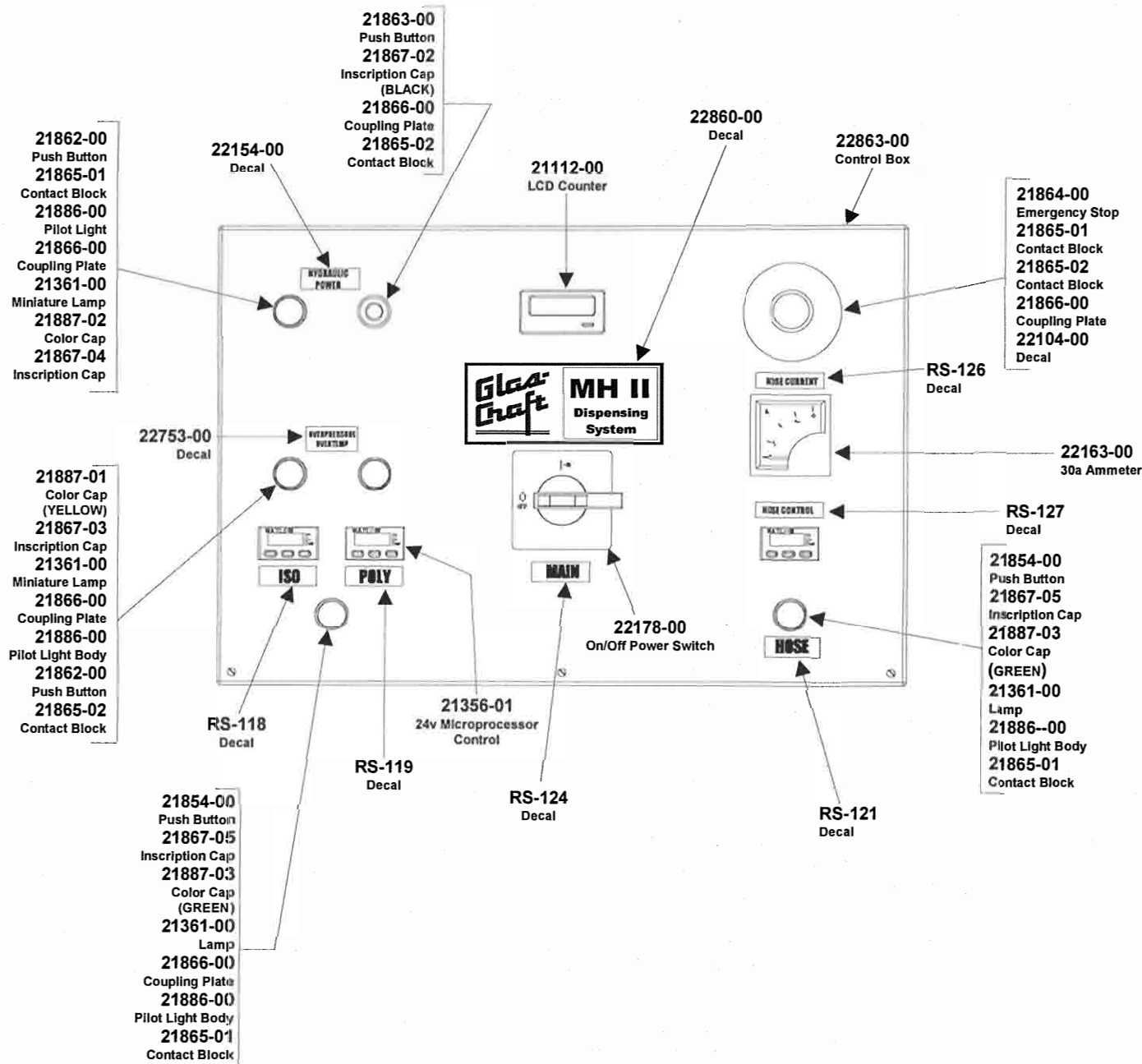

22852-XX MH II CONTROL BOX ASSEMBLY

22527-00
Wiring Duct Cover
22528-01
Wiring Duct

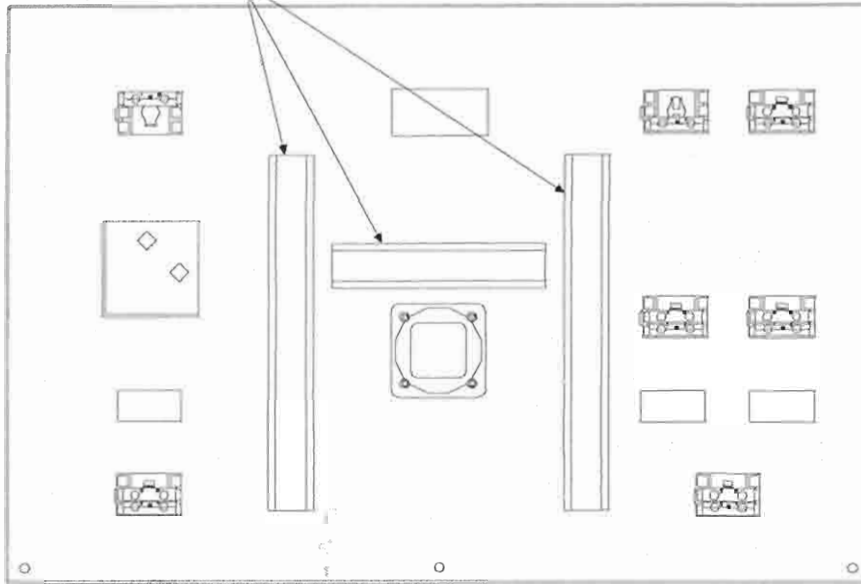

View BB

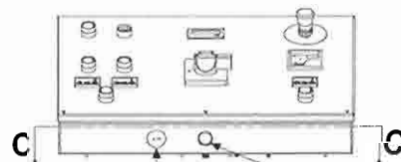
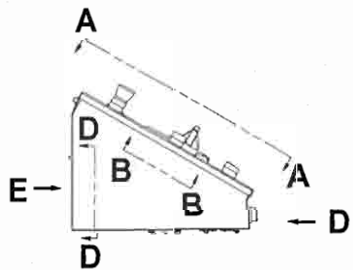

21335-00
Panel Jack
21333-00
Thermocouple Wire

2:2150-02
Pilot Light
2:1866-00
Coupling Plate
21886-00
Mounting Lamp Block
17702-00
Pilot Lamp

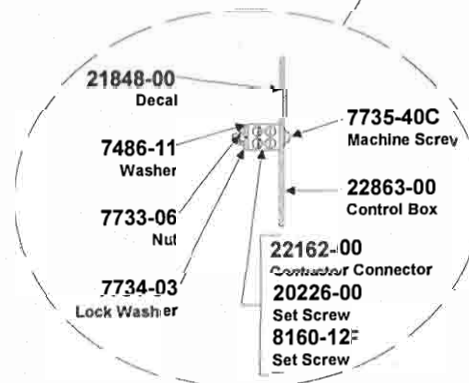
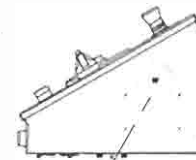

22852-XX MH II CONTROL BOX ASSEMBLY

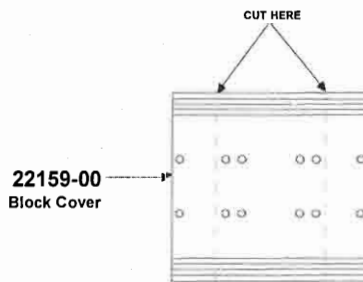
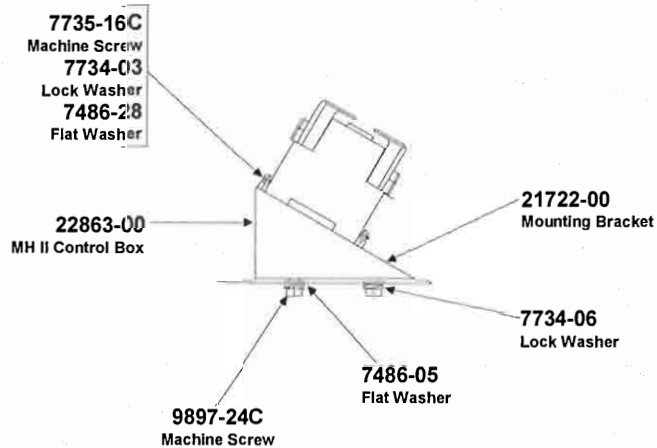
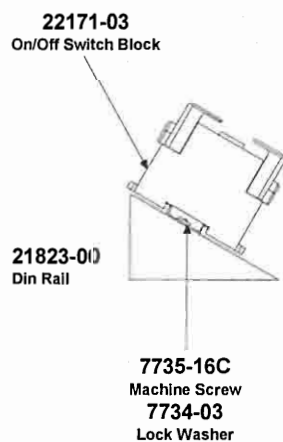
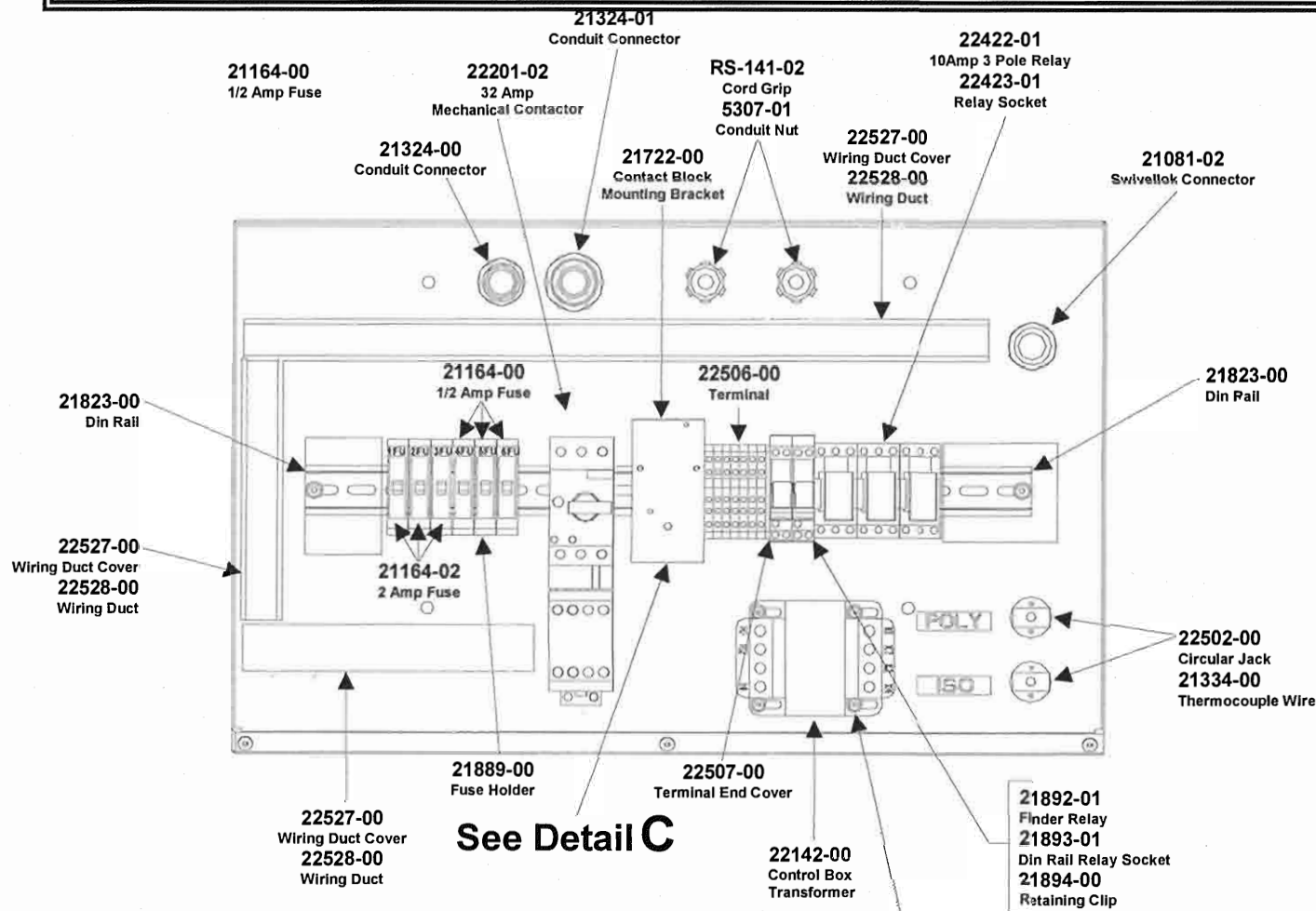

View G

TO BE CUT ONLY WHEN USING WITH 22852-03

GLAS-CRAFT P/N	PHASE	△	△	△	△	△	△
22852-01	200 V, 3-PHASE 5 HP, 50 Hz	22888-05	22171-02	22174-03	22849-02	22137-02 G2 400V	22139-02
22852-02	200 V, 3-PHASE 5 HP, 50 Hz	22888-07	22171-01	22174-01	22849-01	22137-01 G1 400V	22139-01
22852-03	200 V, 3-PHASE 5 HP, 50 Hz	22888-07	22171-02	22174-02	22849-02	22137-02 G2 400V	22139-02

22852-XX MH II CONTROL BOX ASSEMBLY

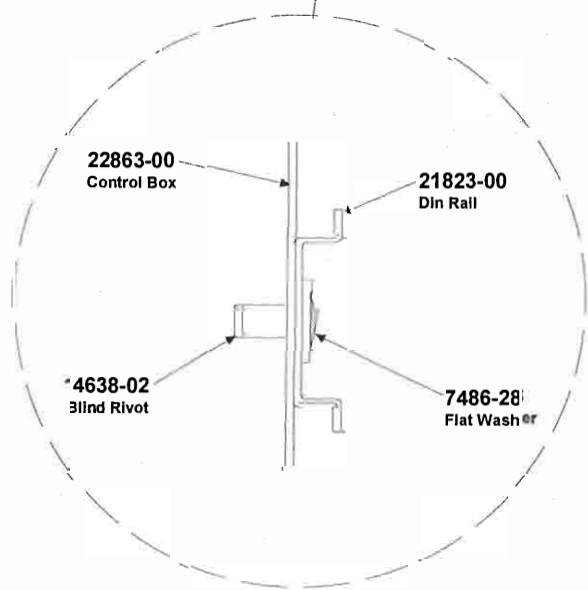
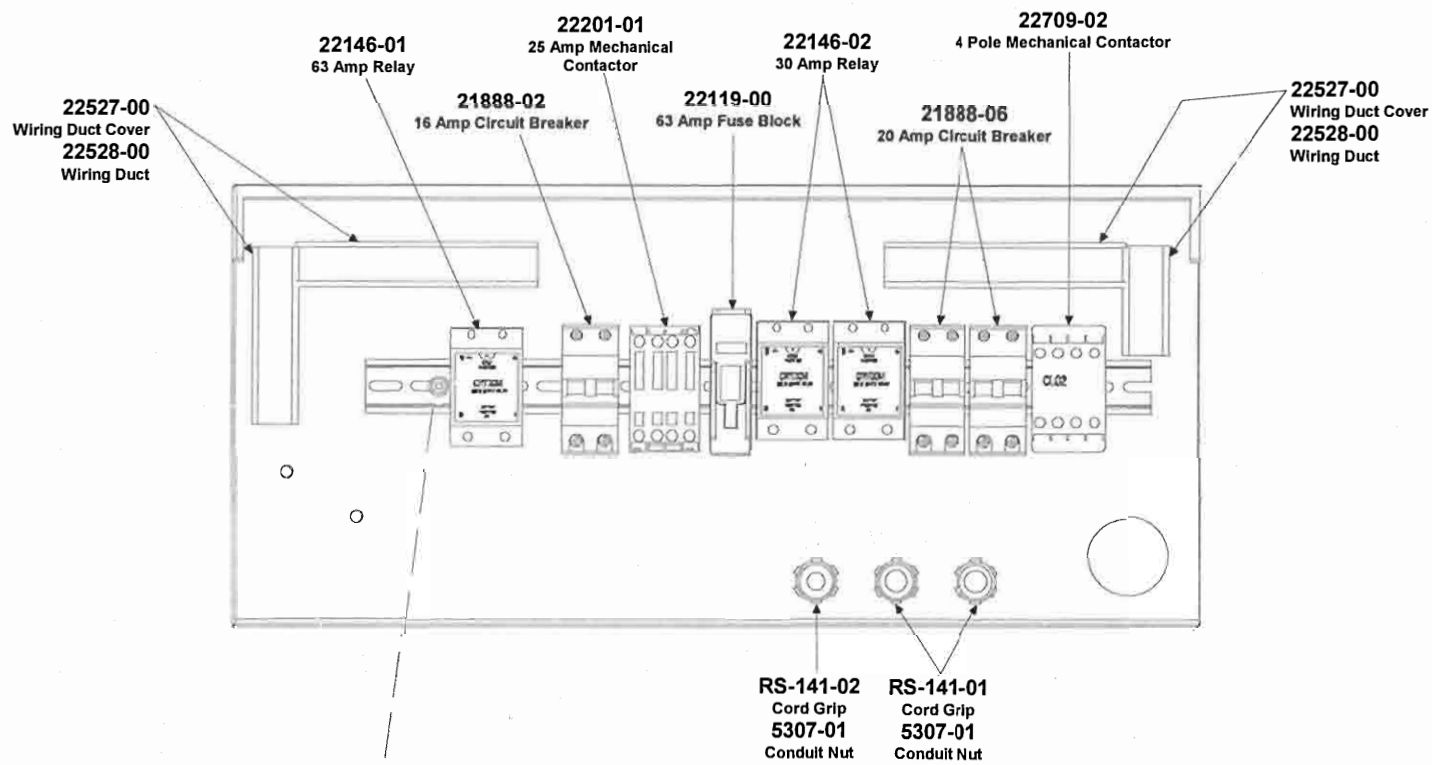

22852-XX MH II CONTROL BOX ASSEMBLY

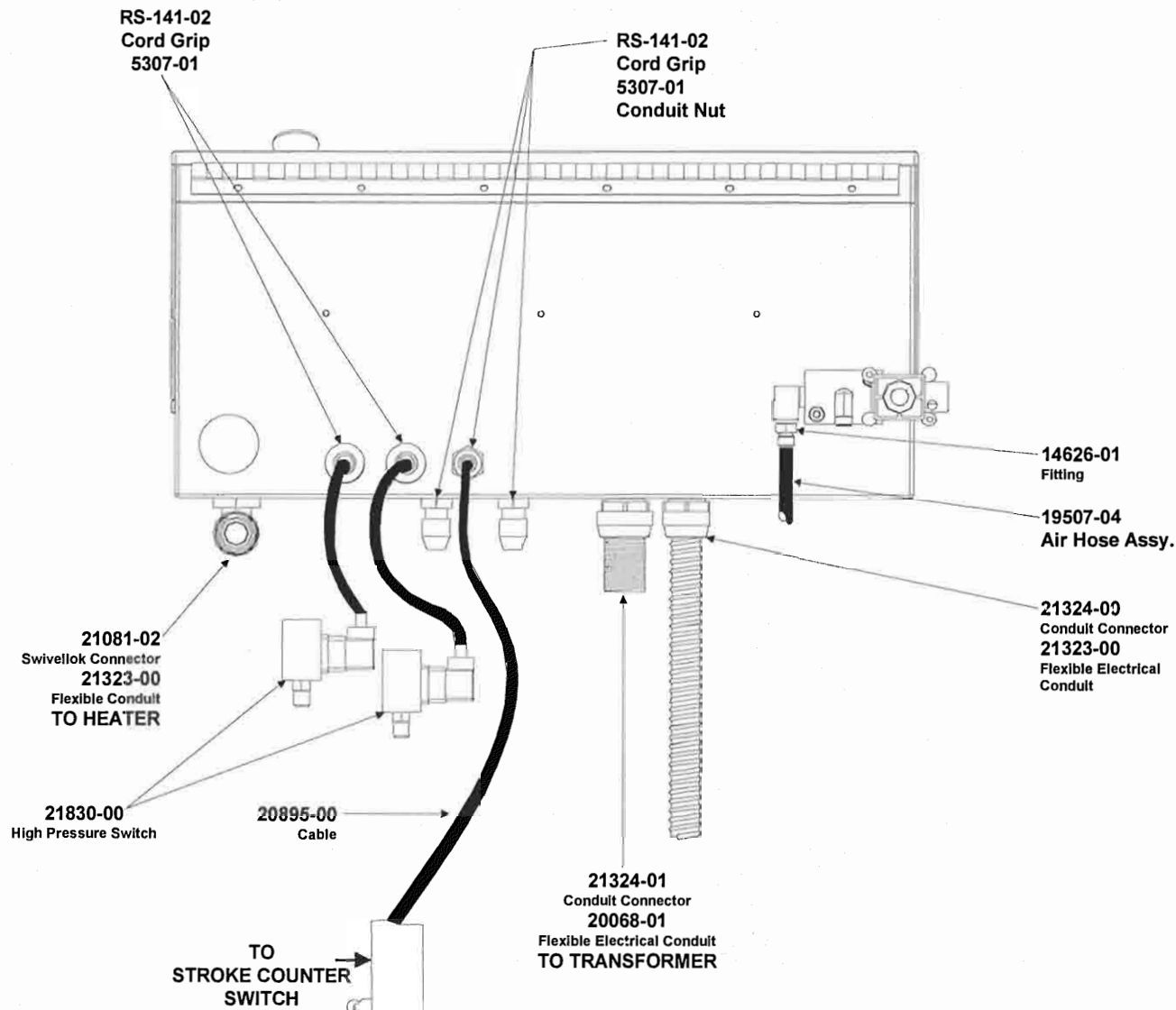

View E

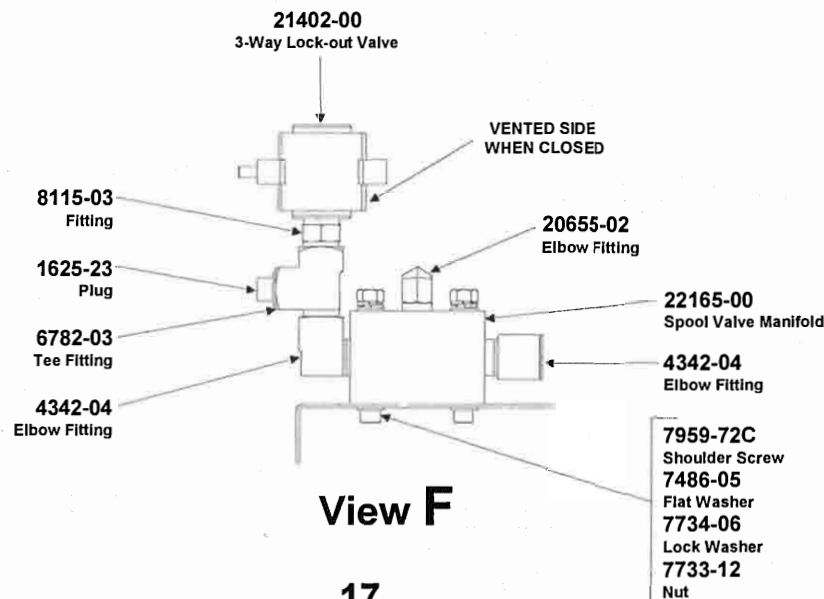

View F

22852-XX SCHEMATIC

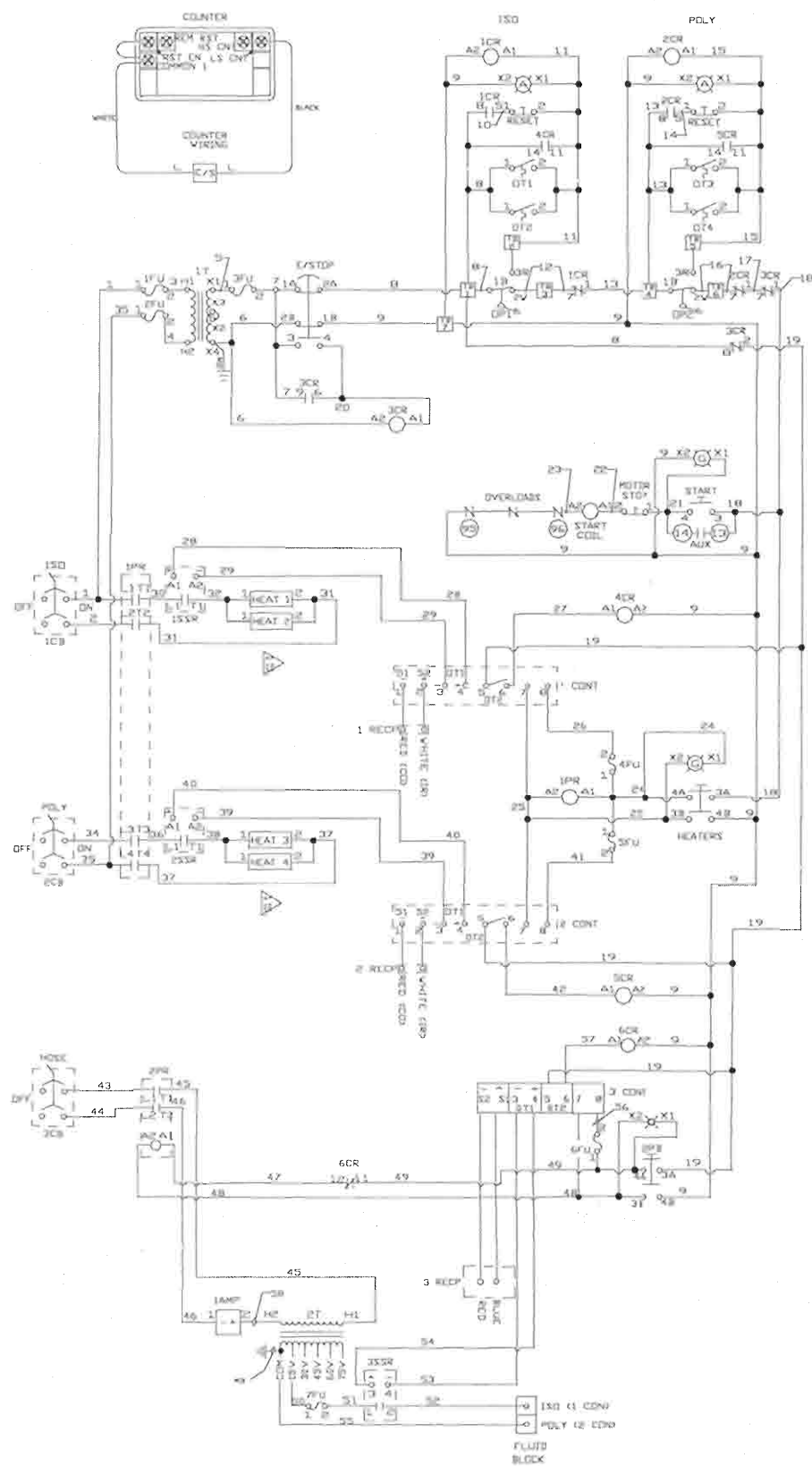

22852-XX SCHEMATIC VARIATIONS

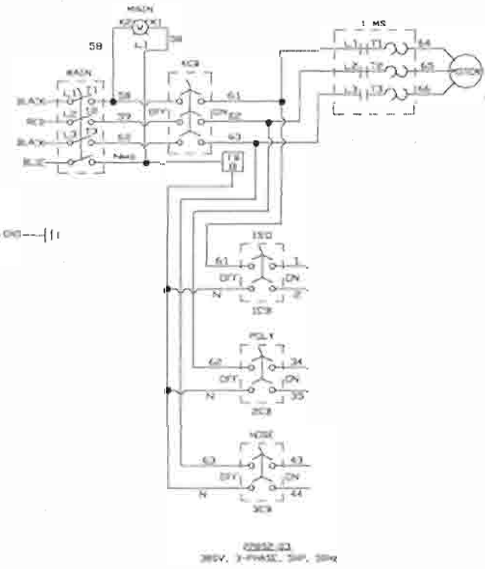
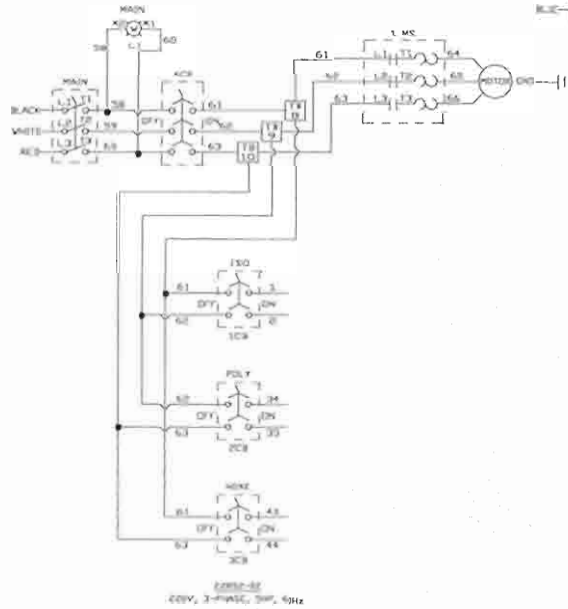
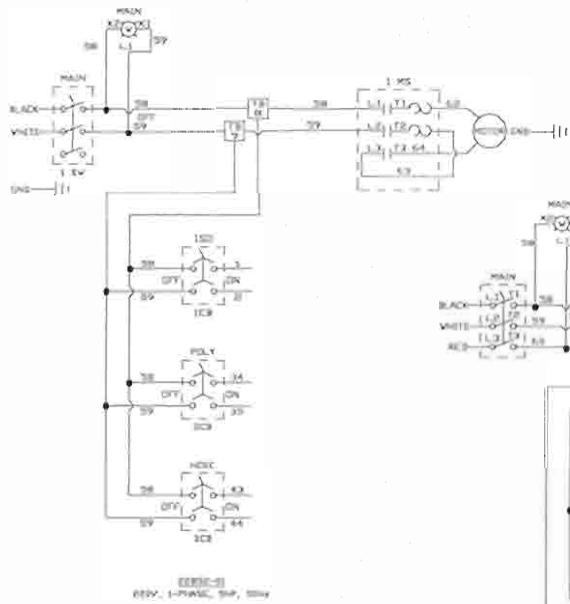

380V, 3-PHASE 380 VOLTS 50 HZ
220V, 3-PHASE 220 VOLTS, 60 HZ
220V, 1-PHASE, 5HP, 60HZ

21835-00 FLUID SECTION ASSEMBLY

RATIO:1:1

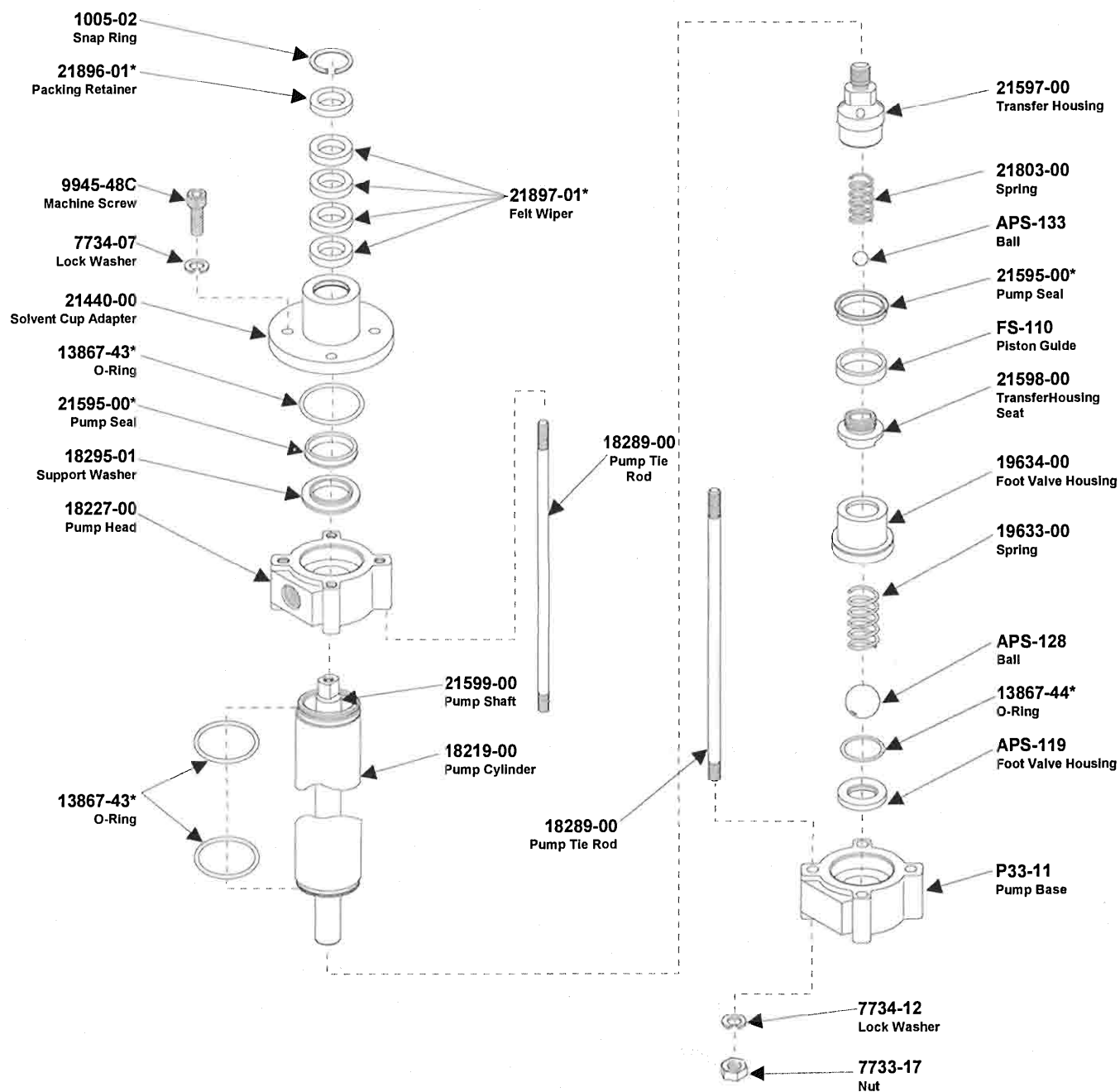

REPAIR KIT: 21845-00

(* Indicates parts included in Repair Kit.

22075-00 DUAL HEAT EXCHANGER ASSEMBLY

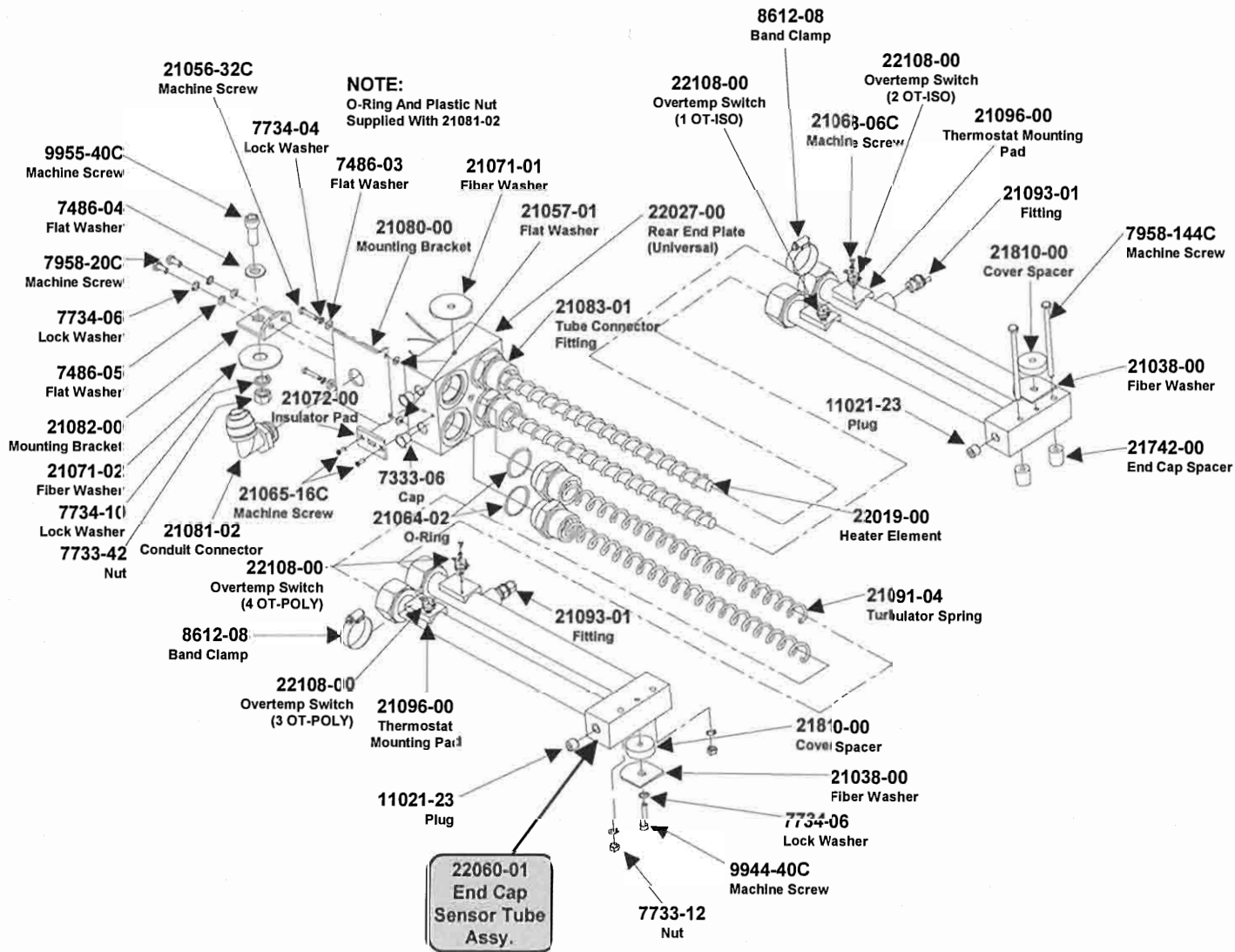

HEATER WIRING DIAGRAM

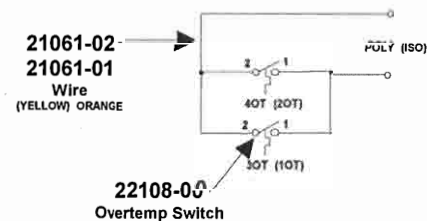

REVISED 7/03

19524-01 MANUAL HOSE ASSEMBLY

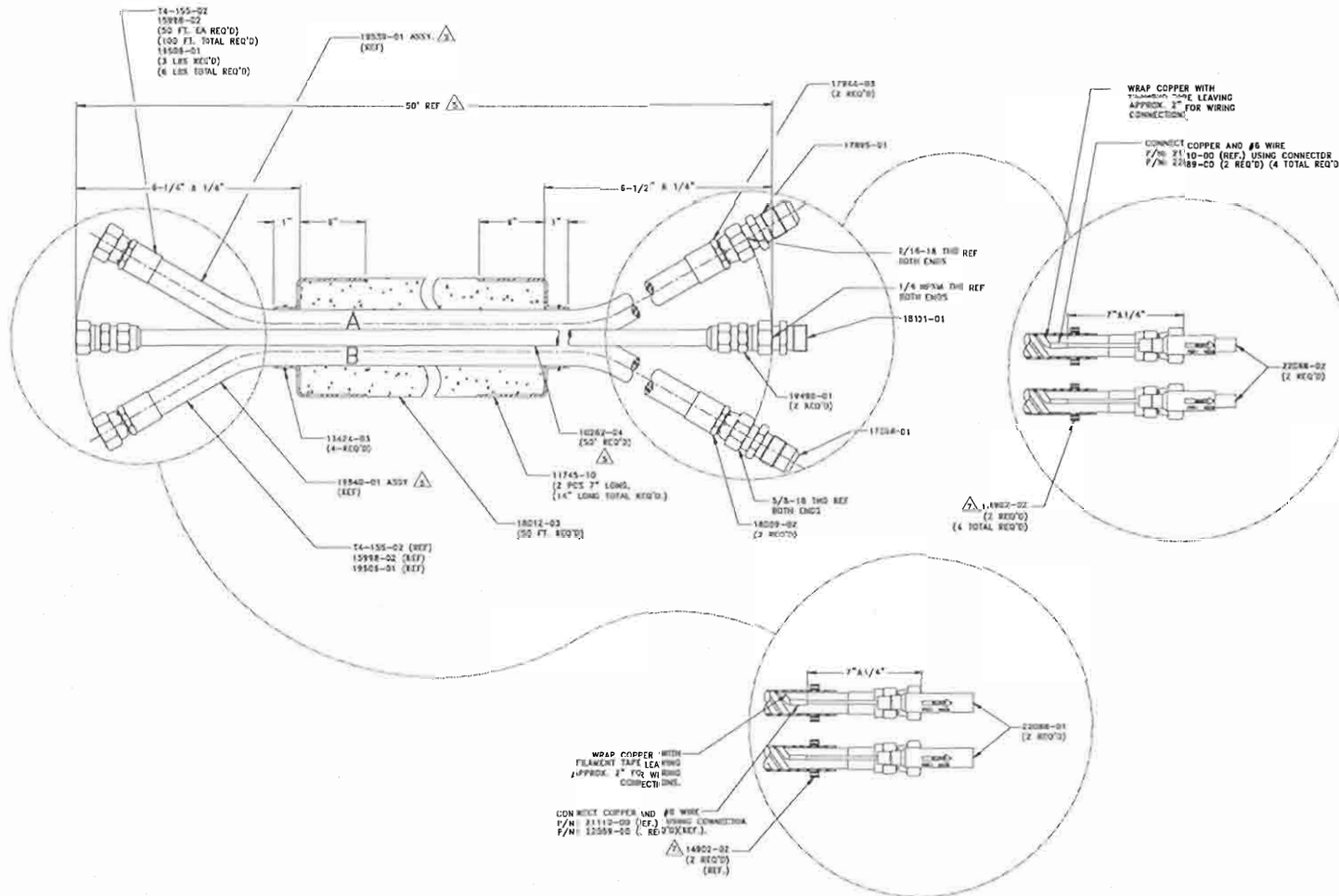

TYPICAL SYSTEM CONNECTION DIAGRAM FOR 50 ft. applications

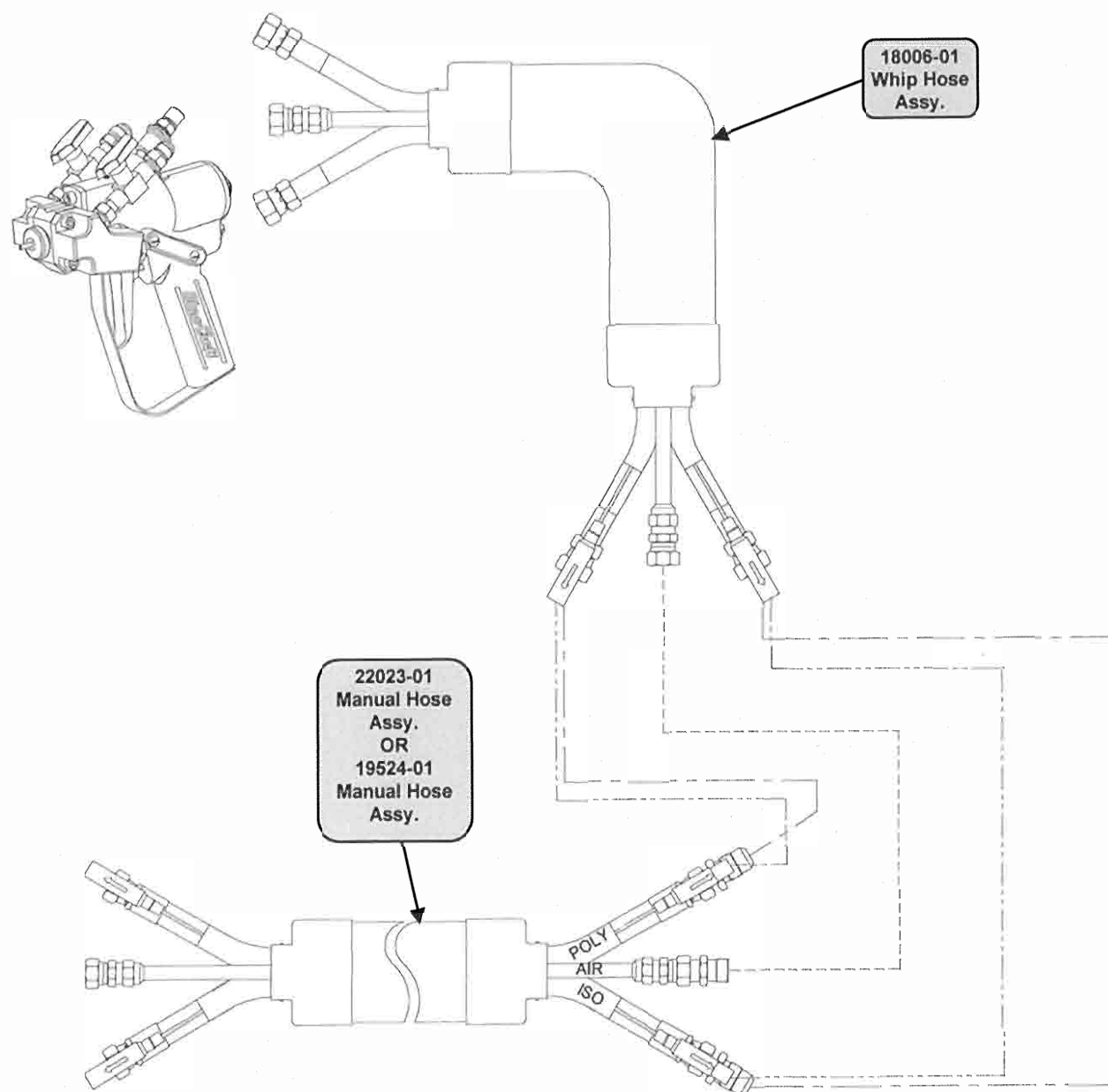

TYPICAL MATERIAL FLOW SCHEMATIC FOR 50 ft. applications

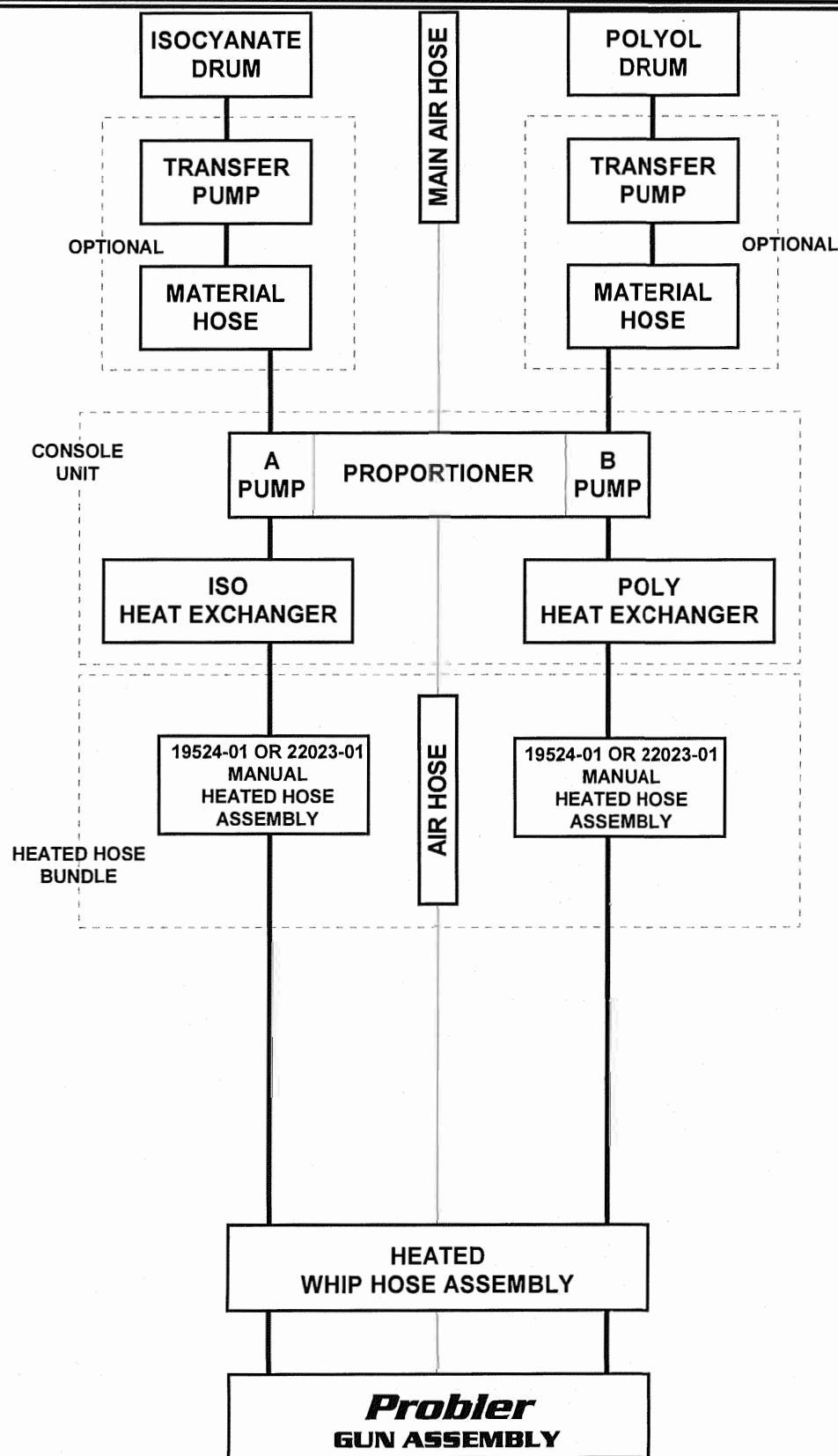

TYPICAL SYSTEM CONNECTION DIAGRAM FOR 100-300 ft. applications

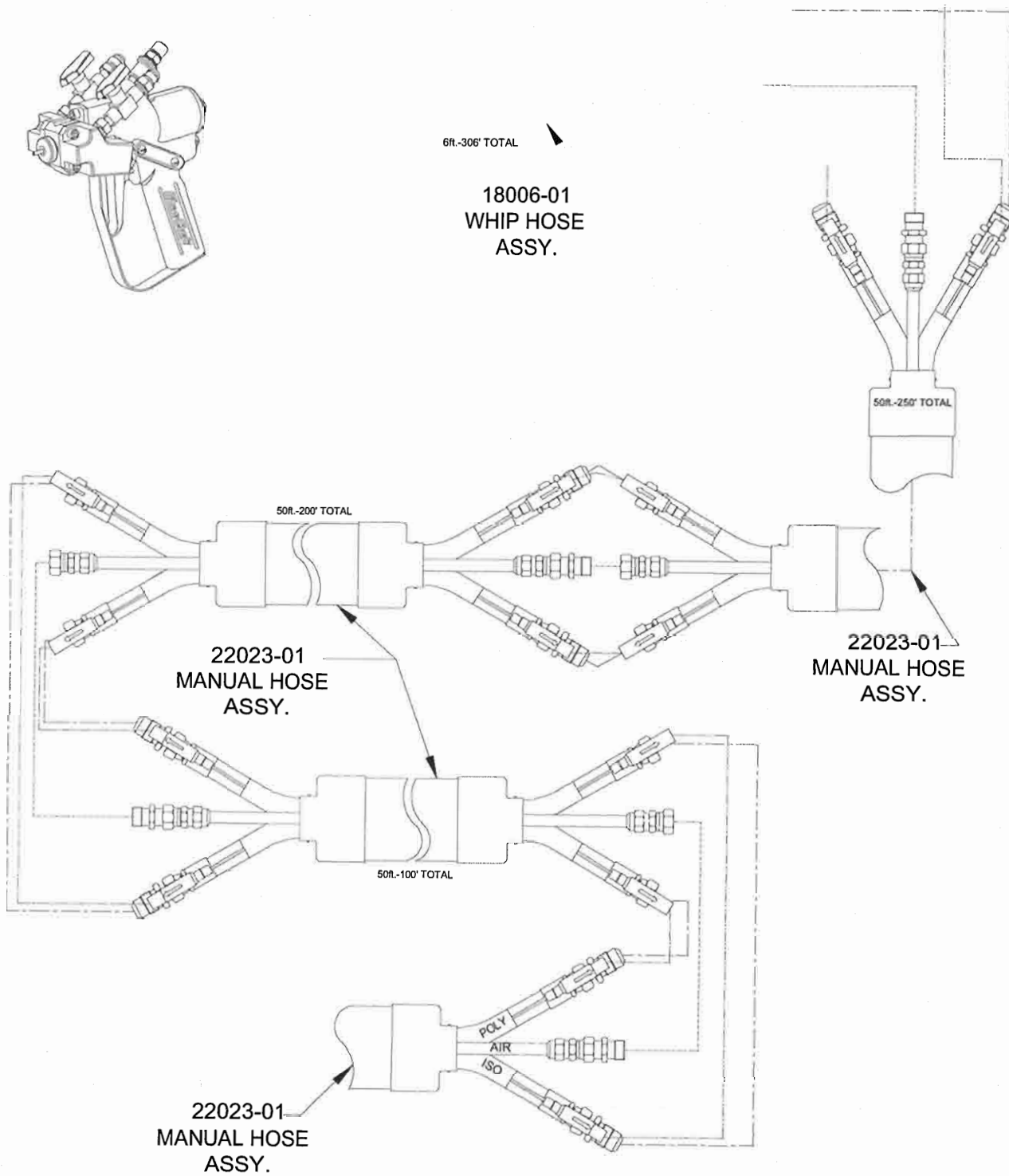

TYPICAL MATERIAL FLOW SCHEMATIC FOR 100-300 ft. applications

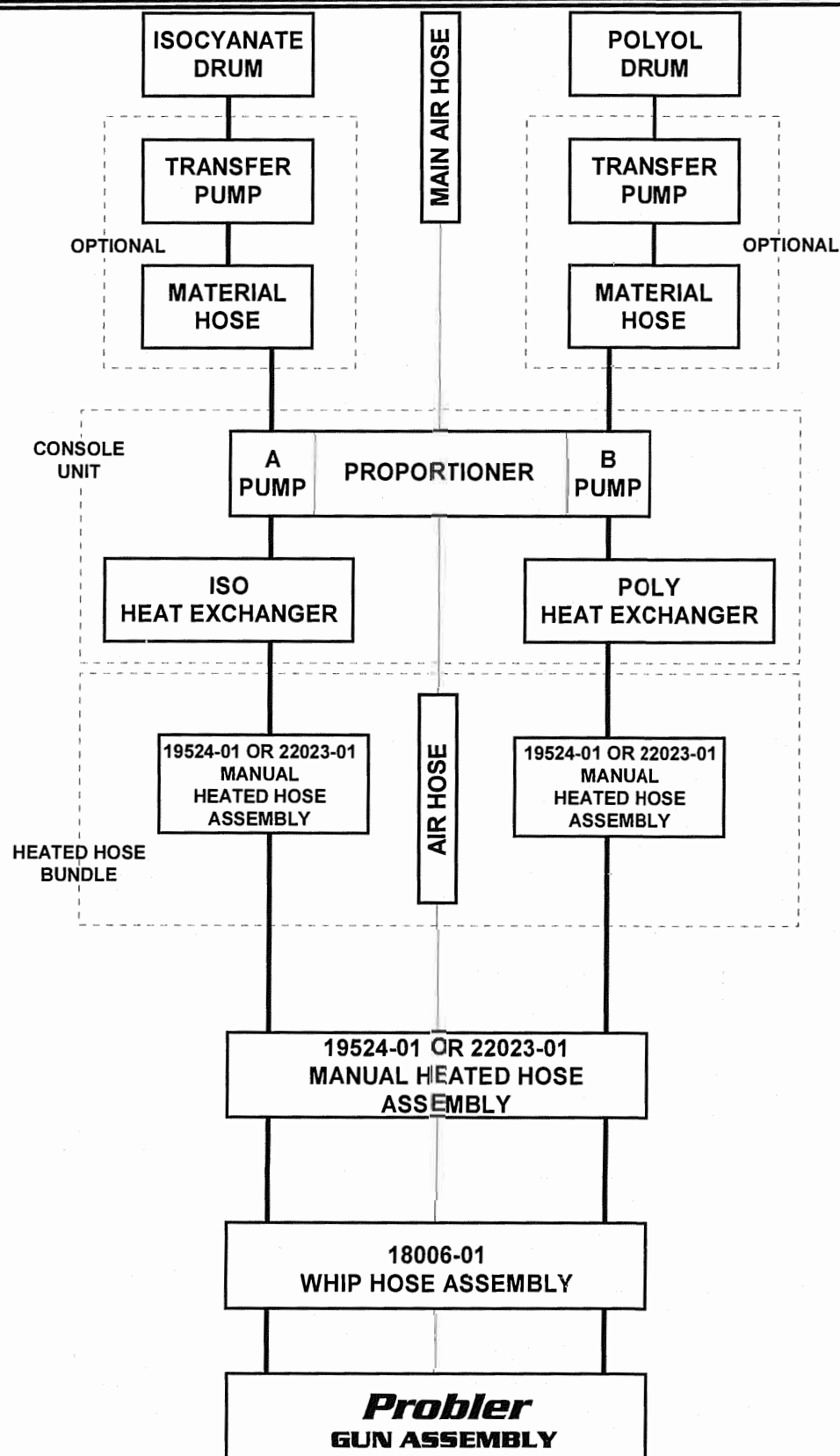

SAFETY

URETHANE SAFE HANDLING and USE of FOAM EQUIPMENT

Introduction

Any tool, if used improperly, can be dangerous. Safety is ultimately the responsibility of those using the tool. In like manner, safe operation of polyester processes is the responsibility of those who use such processes and those who operate the equipment. This manual outlines procedures to be followed in conducting polyester operations safely.

All personnel involved in dispensing operations should read and understand this manual. It is most important that equipment operators, maintenance and supervisory personnel understand the requirements for safe operation.

This manual cannot answer every circumstance; each user should examine his own operation, develop his own safety program and be assured that his equipment operators follow correct procedures. Glas-Craft hopes that this manual is helpful to the user and recommends that the precautions in this manual be included in any such program.

Urethane foam systems are comprised of several different chemical compounds, some of which may be hazardous if improperly used.

CAUTION

Particular caution must be taken with respect to the vapors released during the use of urethane foam systems.

Isocyanate compounds are used in urethane foaming operations. The medical history of persons who may be exposed to such isocyanates should be examined. It is recommended that individuals with a history of chronic respiratory ailments should avoid exposure to all isocyanates.

In addition to the manual, Glas-Craft recommends that the user consult the regulations established under the Occupational Safety & Health Act (OSHA), particularly the following sections:

1910.94 Pertaining to ventilation.

1910.106 Pertaining to flammable liquids.

1910.107 Pertaining to spray finishing operations, particularly Paragraph (m) Organic Peroxides and Dual Component Coatings.

Local codes and authorities also have standards to be followed in the operation of your spraying equipment. Chemical manufacturer's recommendations should be obtained and considered. Your insurance carrier will be helpful in answering questions that arise in your development of safe procedures.

PERSONNEL SAFETY EQUIPMENT

Glas-Craft recommends the following Personal Safety Equipment for conducting safe operations of the Polyester Systems:



EYE
PROTECTION



HEARING
PROTECTION



BREATHING
PROTECTION

Glas-Craft recommends that the user consult the state and local regulations established for all Safety equipment listed.

Operating Safely

In operating urethane foam equipment safely, user should make every effort to:

1. Handle chemicals safely.
2. Provide adequate ventilation.
3. Provide adequate safety equipment (gloves, respirators, safety glasses, protective clothing, etc.) for operators and all others working in areas where they may be exposed to the chemicals or their vapors.
4. Avoid operating equipment which has given any indication of malfunction.
5. Become fully acquainted with the equipment and chemicals used.

Handling Chemicals Safely

Storage of polyisocyanates, diamines, and organic solvents should be isolated and restricted to specially constructed storage rooms. Store chemicals in original containers and according to manufacturer's recommendations listed on the container. Maximum ambient temperatures to which such chemicals should be exposed are specified by the manufacturer and **MUST NOT** be exceeded either in the storage area or in the spraying or pouring area.

To avoid moisture contamination, do not open containers until ready for use. After use, the remaining material should be re-sealed in the original container and stored in areas away from moisture.

During clean-up of spilled isocyanate-component, respirators, gloves and eye protection must be worn. Isocyanates which have been spilled can be controlled by covering them with dry saw dust and/or other absorbent inert materials. Care should be taken to avoid skin contact. The absorbent material and the absorbed isocyanate should be collected promptly, placed in an open-top container, and treated with dilute solutions of ammonium hydroxide and/or alcohol. While being treated in this manner, the material should be in an adequately ventilated area. Clothing on which any material has been spilled should be removed immediately, and cleaned before being worn again.

Clean-Up Solvents

WARNING

A hazardous situation may be present in your pressurized fluid system!

Halogenated Hydrocarbon Solvents can cause an explosion when used with aluminum or galvanized components in a closed (pressurized) fluid system (pumps, heaters, filters, valves, spray guns, tanks, etc.).

The explosion could cause serious injury, death and/or substantial property damage.

Cleaning agents, coatings, paints, etc. may contain Halogenated Hydrocarbon Solvents.

Some Glas-Craft spray equipment includes aluminum or galvanized components and will be affected by Halogenated Hydrocarbon Solvents.

A. There are three key elements to the Halogenated Hydrocarbon (HHC) solvent hazard.

1. **The presence of HHC solvents.** 1,1,1-Trichloroethane and Methylene Chloride are the most common of these solvents. However, other HHC solvents are suspect if used; either as part of paint or adhesives formulation, or for clean-up or flushing.

2. **Aluminum or Galvanized Parts.** Most handling equipment contains these elements. In contact with these metals, HHC solvents could generate a corrosive reaction of a catalytic nature.

3. **Equipment capable of withstanding pressure.** When HHC solvents contact aluminum or galvanized parts inside a closed container, such as a pump, spray gun, or fluid handling system, the chemical reaction can, over time, result in a build-up of heat and pressure, which can reach explosive proportions.

When all three elements are present, the result can be an extremely violent explosion. The reaction can be sustained with very little aluminum or galvanized metal: **any amount of aluminum is too much.**

B. The reaction is unpredictable. Prior use of an HHC solvent without incident (corrosion or explosion) does **NOT** mean that such use is safe. These solvents can be dangerous alone (as a clean-up or flushing agent) or when used as a component of a coating material. There is no known inhibitor that is effective under all circumstances. Furthermore, the mixing of HHC solvents with other materials or solvents, such as MEK, alcohol, and toluene, may render the inhibitors ineffective.

C. The use of reclaimed solvents is particularly hazardous. Reclaimers may not add any inhibitors, or may add incorrect amounts of inhibitors, or may add improper types of inhibitors. Also, the possible presence of water in reclaimed solvents could feed the reaction.

D. Anodized or other oxide coatings cannot be relied upon to prevent the explosive reaction. Such coatings can be worn, cracked, scratched, or too thin to prevent contact. There is no known way to make oxide coatings or to employ aluminum alloys, which will safely prevent the chemical reaction under all circumstances.

E. Several solvent suppliers have recently begun promoting HHC solvents for use in coating systems. The increasing use of HHC solvents is increasing the risk. Because of their exemption from many State Implementation Plans as Volatile Organic Compounds (VOC's), their low flammability hazard, and their not being classified as toxic or carcinogenic substances, HHC solvents are very desirable in many respects.

WARNING

If you are now using Halogenated Hydrocarbon solvents in pressurized fluid systems having aluminum or galvanized wetted parts, IMMEDIATELY TAKE THE FOLLOWING STEPS:

- > Empty system, shut-off, completely depressurize in accordance with equipment service instructions.*
- > Remove equipment from service, disassemble in accordance with equipment servicing instructions.*
- > Inspect all parts for corrosion and/or wear. Replace any damaged parts.*
- > Thoroughly clean all parts of the equipment with a non-halogenated solvent and reassemble in accordance with equipment servicing instructions.*
- > Flush equipment with non-halogenated solvent.*
- > Do NOT reuse equipment with HHC solvents or with materials containing such solvents.*
- > Material suppliers and/or container labels should be consulted to ensure that the solvents used are compatible with your equipment.*

NOTE

Glas-Craft is aware of NO stabilizers available to prevent Halogenated Hydrocarbon solvents from reaction under all conditions with aluminum components in a closed fluid system.

TAKE IMMEDIATE ACTION...

Halogenated Hydrocarbon solvents are dangerous when used with aluminum components in a closed fluid system.

F. Consult your material supplier to determine whether your solvent or coating contains Halogenated Hydrocarbon Solvents.

G. Glas-Craft recommends that you contact your solvent supplier regarding the best non-flammable clean-up solvent with the heat toxicity for your application.

H. If, however, you find it necessary to use flammable solvents, they must be kept in approved, electrically grounded containers.

I. Bulk solvent should be stored in a well-ventilated, separate building, 50 feet away from your main plant.

J. You should allow only enough solvent for one day's use in your laminating area.

K. "NO SMOKING" signs must be posted and observed in all areas of storage or where solvents and other flammable materials are used.

L. Adequate ventilation (as covered in OSHA Section 1910.94 and NFPA No. 91) is important wherever solvents are stored or used, to minimize, confine and exhaust the solvent vapors.

M. Solvents should be handled in accordance with OSHA Section 1910.106 and 1910.107.

Toxicity of Chemicals

A. Glas-Craft recommends that you consult OSHA Sections 1910.94, 1910.106, 1910.107 and NFPA No. 33, Chapter 14, and NFPA No. 91.

B. Contact your chemical supplier(s) and determine the toxicity of the various chemicals used, as well as the best methods to prevent injury, irritation and danger to personnel.

C. Also determine the best methods of first aid treatment for each chemical used in your plant.

First Aid

If chemicals containing isocyanates are splashed on the skin, they can produce ill effects. Steps to counteract such effects should be started immediately.

1. Apply Tincture of Green Soap, full strength, to the contaminated area. If Tincture of Green Soap is not immediately available, wash the exposed area repeatedly with soap and water. Soap and water is not as desirable as using Tincture of Green Soap because many isocyanate components are not easily dissolved in water. In addition, soap and water does not form a barrier to the isocyanates.

2. After approximately two to four minutes, wash off the Tincture of Green Soap with water. If there is still an indication of isocyanate present, repeat the application. If the isocyanate contamination is on the facial area, care must be taken to avoid getting the Tincture of Green Soap in the eyes.

3. If the person develops breathing difficulties, oxygen should be administered. Quite often the exposed person will experience residual effects such as coughing spells. **CONTACT PHYSICIAN IMMEDIATELY.**

WARNING

Contact a doctor immediately in the event of an injury and give him the information you have collected. If your information includes first aid instructions, administer first aid immediately while you are contacting the doctor.

4. If a person accidentally swallows isocyanates, large amounts of water should be swallowed immediately. Vomiting should then be induced by patient sticking his finger down his throat, or by swallowing large quantities of warm salt water or warm soapy water. After vomiting, more water should be taken to dilute isocyanate further. **CONTACT PHYSICIAN IMMEDIATELY.**

Ventilation

WARNING

Hazardous concentrations of some chemical vapors exist before they can be smelled. Chemical component suppliers should be contacted to determine at what concentrations the vapors of the chemicals they supply become dangerous, and the procedures and equipment needed to detect such dangerous concentrations. Such equipment should be obtained.

Adequate ventilation must be provided in any area where foam chemicals are sprayed or poured, and wherever the material containers are opened.

In industrial applications, foaming operations should be restricted to specific areas, and proper ventilation should be provided in these areas to prevent chemical vapors from spreading. Spray foaming operations **MUST** be restricted to a spray booth where a minimum exhaust of 100 feet per minute at the face of the booth is provided. Special care should be taken to prevent unsuspecting personnel both inside and outside of the plant from being exposed to chemical vapors. The chemical vapors should be exhausted to atmosphere in such a manner and at a sufficiently low concentration that personnel outside the plant are not exposed to dangerous concentrations of chemical vapors. Refer to OSHA Standards, sub-part G, 1910.107 and particularly sub-section (m) for Federal standards. State and local authorities may have applicable statutes or regulations concerning ventilation.

n contractor applications (for example, at a construction site, inside building or other enclosed space), the forced ventilation normally provided is likely to be inadequate. These applications, therefore, usually **REQUIRE** the use of forced, fresh air respirators for all persons in the areas where foaming operations are conducted or where the chemical vapors are likely to spread.

In industrial and contractor applications, it is advisable to run frequent tests to determine the exact concentration of isocyanate vapor in the air. Industrial equipment is available for making such determinations. Your chemical supplier can recommend such equipment and procedures.

Proper Safety Equipment

All persons spraying or working in areas where forced air ventilation is not adequate to remove isocyanate vapors from the air **MUST** use an approved (U.S. Bureau of Mines) fresh air supplied respirator.

Respirators should be regularly inspected, cleaned and disinfected according to good practices. Records must be kept of the inspections. The user **MUST** have a medical clearance indicating that he can safely use a respirator.

Respirators must fit securely; beards prevent a tight seal around the face. Eye glasses have to be given special attention and contact lenses are prohibited.

Safety goggles, gloves and other protective devices are suggested for operators of foaming equipment. Refer to OSHA Standards, sub-part 1, 1910.132, 1910.133 and 1910.134 for Federal standards.

IF YOU HAVE ANY QUESTIONS REGARDING THE ABOVE PRECAUTIONS OR ANY SERVICE OR OPERATION PROCEDURES, CALL YOUR GLAS-CRAFT DISTRIBUTOR OR GLAS-CRAFT, INC.

NOTICE

All statements, information and data given herein are believed to be accurate and reliable but are presented without guaranty, warranty or responsibility of any kind expressed or implied. The user should not assume that all safety measures are indicated or that other measures are not required.

GLAS-CRAFT, Inc.

5845 WEST 82nd STREET, SUITE 102
INDIANAPOLIS, INDIANA 46278 U.S.A.

PHONE (317) 875-5592

FAX (317) 875-5456

APRIL 1996

INSTALLATION

Assembly Instructions

NOTE

The Glas-Craft MH II System is factory assembled. If any questions arise concerning air or electrical connections, please refer to illustrations located in the forward portion of this User Manual or contact your Glas-Craft distributor.

A. Fluid Line Connection

1. The fluid lines that bring Isocyanate and Polyol from the drums to the pump inlets, and the hoses that take the chemicals and the air from the isolation hose to the gun should be connected as follows.

WARNING

Disconnect or turn **off** Main Power source before opening Control Panels Boxes to make any repairs or before making any electrical repair or working on hose lengths of any type to the MH II system.

2. Connect Hose Assembly P/N 19524-01 or 22023-01 to front of the unit. The fittings on the unit are sized differently and will attach only one way. (Match like sized fittings.) Also connect the air hose at this time. A small junction hose is supplied that attaches to the hose to the air manifold.

NOTE

To connect any additional extension hose assemblies, P/N 19524-01, or 22023-01 use fitting P/N 18101-01 P/N 17895-01 and 17896-01. Each fitting should be securely tightened into swivel hose fitting using proper sized wrenches.

3. Connect Whip Hose P/N 18006-10 to Hose Assembly, P/N 19524-00 or 22023-00.

NOTE

The 10' Heated Whip also serves as a turn around block.

The Whip Hose Assembly should now be attached to the gun. The swivel fittings on the Whip Hose Assembly are sized differently and will attach only one way. Also connect the Air Hose Assembly to the gun at this time.

Fluid hose connections between console and the gun should now be complete. The following should be checked before proceeding.

1. All fittings should be tight from Isolation Hose to the gun.
2. All Union Fittings and Air Line Unions used between hose sections should be wrapped individually with several layers of electrical tape to prevent short circuiting of the hoses.
3. The Transformer can now be set for proper hose length. See Place card.

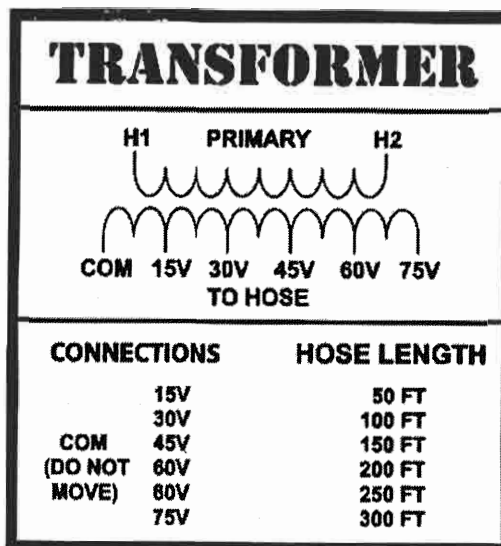

CAUTION

Hose Assemblies are constructed of durable, rugged materials, however they are not indestructible. To provide precisely controlled heated material, the hoses have electrical wiring wrapped between layers. Avoid dragging hoses over or around sharp, abrasive edges and corners. Exercising caution and common sense will give long, and reliable service from the hoses.

B. Installation Instructions for Hoses

When installing Hose on system, or adding Hoses together, the following instructions are important to follow.

Required Tools:

Wrenches, open-end 5/8", 3/4", 13/16"

1. Lay Hose out straight
2. Couple Hoses together with supplied Union Fittings. Connect Fittings finger-tight.
3. Hold Crimp Fitting hex [3a], 3/4", and Union Fitting [3b], 5/8" together, allowing Hose to hold it's natural line. Place appropriate wrench on Swivel Fitting [3c] (A-side 3/4" wrench, B-side 13/16"). Tighten Swivel to Union, not allowing Crimp Fitting or Union to turn. Repeat on opposite side of Union. (see Fig. 1a and 1b)



Fig 1a

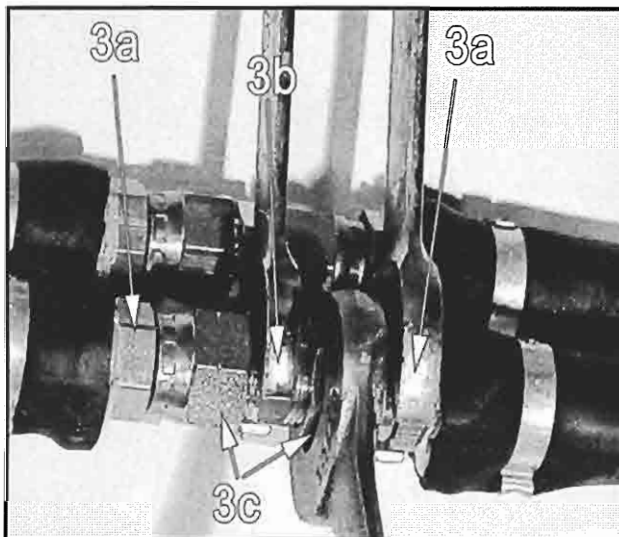

Fig 1b

This practice is required on all connection points.

Hose @ Machine
Hose @ Gun

4. Plug Hoses Together.
The TRU-FLOW Hose plugs a turn lock design. The Plugs will need to be pushed together and turned into lock position.

Once connections are made, tape up connections well enough to):

1. Keep plugs from coming undone.
 2. Protect plugs and wires from damage, becoming snagged, etc.
5. Install thermocouple at Tee on B-Side of machine manifold.
 - a. The 12' line will go in the hose.
 - b. Nut and Ferrules will lock into fitting.
 - c. Tighten nut down 1 1/4 turns past finger tight.
 - d. Plug thermocouple into Control Box.

C. Optional Transfer Pump Installation

Remove large drum bunghole cover and install material transfer pump bung adapter. Carefully lower material transfer pump into the drum, until it touches the bottom of the drum.

Connect material Transfer Pumps to the unit by using the material Transfer Hose Kit, P/N 17661-01.

D. Optional Air Dryer Kit

P/N AD-100 should be installed on the material drums.

E. Electrical Connections

The incoming cable is **NOT** supplied by the manufacture.

35 AMP @ 208/240 VAC 50/60 HZ Three Phase
L1 L2 L3 GROUND

If rotation is not correct, switch any two lead wires.

27 AMP @ 380 VAC 50/60 HZ Three Phase
L1 L2 L3 N GROUND

If rotation is not correct, switch any two lead wires.

74 AMP @ 208/240 VAC 50/60 HZ Single Phase
L1 L2 GROUND

Motor rotation will not be affected on Single Phase.

CAUTION

If you do not understand the electrical hook-up described above, consult your local Glas-Craft distributor OR a qualified electrician.

It is recommended that a qualified, licensed electrician should install power to the supply disconnect.

You should always follow all local or national electrical codes.

Fluids containing anti-wear additives are recommended for optimum service life.

F. Hydraulic Pack

The Hydraulic Pack Tank is empty when shipped from Glas-Craft. The tank **MUST** be filled before operation.

Tank Capacity: 20 GAL / 75.7 LITER

Recommended Hydraulic Fluid: Iso grade 32, 46, or 68.

OPERATION

Pre-Operation Checklist

- A. Check that *all* fittings are securely tight.
- B. Check electrical hook-up (*qualified* electrician recommended).
- C. Circuit Breaker on Control Box should be switched to **OFF** position.

WARNING

*Do not place any part of the body in the path of the material spray.
Do not point the gun at or near other personnel.
Do not look into the Mixing Chamber orifice at any time.
Because of the hazardous materials used in this equipment, it is recommended that the operator use an air mask, goggles, protective clothing, and other safety equipment as prescribed by current regulations, recommendations of the chemical suppliers, and the laws in the area where the equipment is being used.*

A. Initial start-Up Procedure

With all material and air lines connected and power cable attached, the system is now ready for start-up.

Filling The System

1. With all material and air lines connected and power cable attached to the system, the system is now ready to be filled with material. With transfer pumps in place, adjust regulators on transfer pumps to 30-50 psi to fill the system. Transfer pumps will cycle to fill pumps and heaters, then stop. At that point, increase PSI to 100 PSI.

NOTE

Turn Transfer pump Air Regulator on slowly. Pumps should cycle slowly until hoses are full of material.

2. Remove the Side Blocks, P/Ns T4-143 and T4-144, on the front housing of the Gun, by removing Screws, P/N 9944-48C.

3. Place separate clean containers under each individual Side Block. Open manual Material Valves (black arrow forward, see Fig. 2 & 3) on each Side Block to allow trapped air to escape the Hose and material to flow into the containers until all air is purged from the material system. (see Fig. 1)

This process can be expediated by starting the main proportioner and allowing it to cycle slowly.

Maximum Cycle rate = 10 Cycles / min.

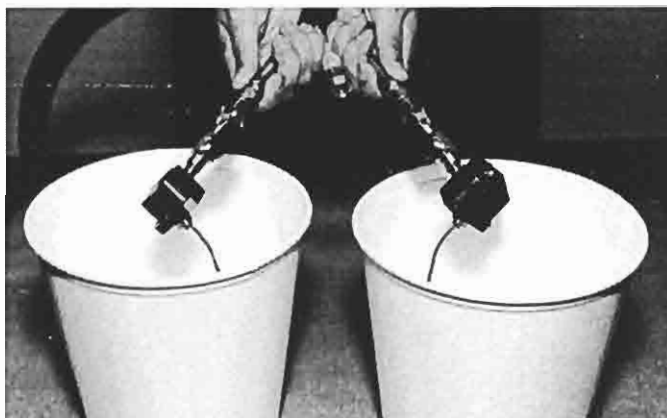

Fig. 1

NOTE



Remember to dispense one to two gallons of material to clear the system of grease and plasticizer that was used during factory testing.

4. Close manual Material Valves. Material pressures gauges should now register approximately equal pressure. If one side registers considerably more pressure than the other side, go to the high pressure side and bleed off some pressure by slightly opening the manual Material Valve on the Side Block over the container. Bleed pressure until both sides are approximately the same pressure.

5. Dispose of waste material properly and in accordance with chemical suppliers instructions and local, state and federal regulations.

NOTE

Before re-assembling Side Blocks, lubrication can be applied by dabbing a white lithium grease into holes inside of Gun Front Housing and wiping grease over Side Block Seals. Grease will purge itself when air valve is turned on at Gun and Gun is triggered.

- Clean and lubricate Side Blocks and Seals thoroughly and re-assemble on Gun. Make certain that Side Block Screws are tighten securely.
- Refer to Chemical Material Operating Instructions for proper preparation of material, i.e, mixers, etc.
- Turn Door Interlock Switch to ON position.
- Turn on Hose Control. This is done by pushing in the green button. Adjust temperature to desired setting by depressing the blue "SET" button and press either  or  button on the Controller simultaneously until desired temperature setting is achieved.

NOTE

Allow proper time for hose to warm up (approximately 30-60 minutes).

NOTE

To adjust temperature on Hose Controller, push and hold in blue button. Then push the up or down arrow to increase or decrease temperature. To see actual temperature of liquid in hose, push blue button once and release. The actual temperature will then be displayed for 20 seconds.

- Turn on the ISO and POLY Heaters. (Green Push Button)
- Adjust temperature to desired setting. ISO and POLY Controllers function exactly the same as the Hose Controller.
- Turn Air on to System. Active with yellow slide valve.

NOTE

Allow proper time for material to be heated (approximately 3-5 minutes).

- Turn on power to Hydraulic Pack. WHITE button is ON.

BLACK button is OFF.

Adjust Pack PSI with remote valve. Observe pressures on both sides rise equally.

NOTE

Ratio of Pumps to Power Pack = 2:1

- Turn Purge Air and Material Valves ON at Gun. (see Fig. 2 & 3)

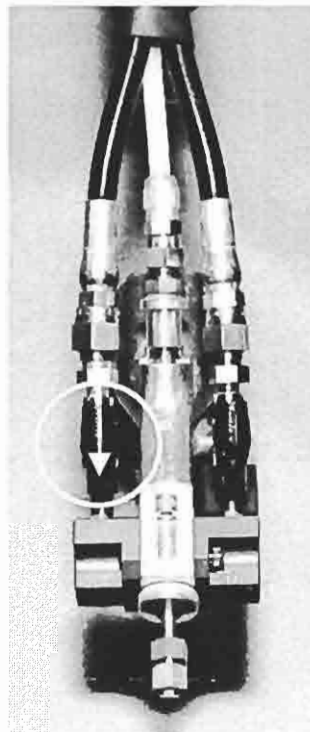

Fig. 2

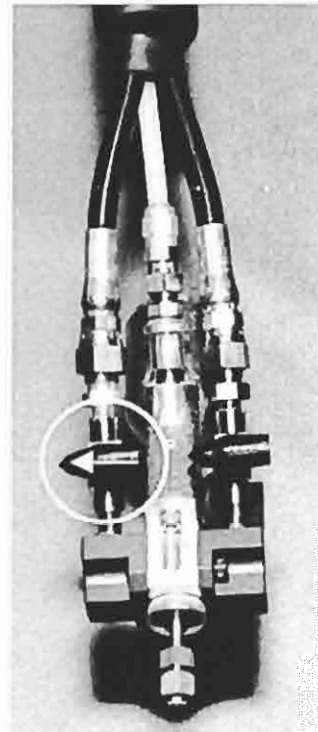

Fig. 3

NOTE

The Emergency Stop Switch is located on the top right side of the Box Panel, when depressed, it will shut down the power and activate the Safety Circuit. To reset, turn handle on push button.

- The system is now ready for operation.

B. OVER PRESSURE SYSTEM PROTECTION

The MH II system incorporates monitors for high pressure monitoring. These monitoring devices will prevent the MH II system from continued operation if high pressure situations develop.

There are pressure sensors located on each proportioning pump. The high pressure sensor is located at the outbound of the fluid section.

The high pressure monitoring sensor will engage if fluid pressure increases above settings.

*Medium PSI. Unit at 2200 PSI.
High PSI. Unit at 2600 PSI.*

If a high pressure situation develops, the sensor will detect this and immediately engage the hold-in circuit.

This will disengage power to the Hydraulic Pack and it will stop cycling. It will also turn the heater off.

On the control box panel, there are two yellow lighted push buttons marked over pressure. One of these push buttons will be illuminated after the monitoring sensor engages, indicating where the problem is located (ISO or Poly).

In the over pressure situation, the system will remain shutdown until it is manually reset.

At this point, it is necessary to determine if the problem is an over pressure situation.

Inspect the fluid pressure gauges, in an over pressure situation, one of the fluid pressure gauges will be significantly higher than the other gauge.

WARNING

When main power to unit is on, the console will have wires that are live. Disconnect or turn off main power source before opening console to make any repairs.

WARNING

Before performing any repairs on the system, ALL AIR and FLUID PRESSURES SHOULD BE RELIEVED TO ZERO (BLEED-OFF)!

C. OVER PRESSURE PROBLEM CORRECTION

1. Determine if the problem is high pressure related.
2. Relieve system hydraulic pressure.
3. Turn off main power
4. Fix the problem area:
 - a. Potential high pressure causes:
 - Restriction
 - Overheating material in static position
 - ISO filter at gun
5. Re-start system for operation

NOTE

For further diagnostics, See "Basic Trouble Shooting Guide" GCI # 1256.

6. Once the power has been turned off and problem solved, and the main power is turned on again, the over pressure lighted buttons will automatically be reset.

Fluid Sections

The wiper/lubrication cup at the top of each fluid section is designed to keep piston shaft clean and lubricate throat seal.

This special design requires very little maintenance.

Each week:

1. Wipe any residue from the mouth of the lubrication cup.
2. Add 1 teaspoon of a suitable lubricating solution.

F. System Shut-Down

1. Flip "Retract" Switch from "Run" position.
2. Trigger Gun to send pumps into full downstroke.
3. Turn off Hydraulic Pack.
4. Turn off Primary Heaters.
5. Turn Main power switch off.
6. Perform Gun maintenance as follows:
 - a. Check for leaking Seals, P/N 16811-00:

- ⑥ Turn OFF Gun incoming air by closing Gun Air Switch.
 - ⑥ Wait approximately 10-20 seconds, then turn ON incoming air by opening Gun Air Switch.
 - ⑥ Repeat two or three times.
 - ⑥ If any material has been purged from the Gun, the Seals, P/N 16811-00 are leaking.
 - ⑥ Correct leaks by replacing seals and re-checking.
- b. Check for leaking Material Valve, P/N PG-15:
- ⑥ Turn OFF both Material Valves.
 - ⑥ Trigger Gun several times.
 - ⑥ Turn OFF Gun incoming air by closing Gun Air Switch.
 - ⑥ Trigger Gun several times.
 - ⑥ If additional material is purged, the Material Valves are leaking.
 - ⑥ Correct leaks by taking off Black Knobs and turning packing 1/8 to 1/4 turns at a time until leak has stopped. Re-check.
- c. Check Side Blocks:
- ⑥ Turn OFF the Air Switch on Gun.
 - ⑥ Take off Side Blocks by removing Screws, P/N 9944-48C.
 - ⑥ Examine the sides of the Mixing Chamber, P/N 17637-XX for scratches and/or material build-up. Carefully, without scratching the seal surfaces (sides), remove any accumulated material. Solvent can be used to wash accumulated material off of Chamber, Side Blocks, etc. Keep Gun Chamber tilted toward the ground so that solvent does not run back into Gun. Certain solvents will attack O-Rings on Chamber Shaft causing swelling and deterioration of O-Rings.
 - ⑥ Place generous amounts of high quality, white lithium grease in each side of the Gun Front Housing and on the Side Block Seals.
 - ⑥ Use a No. 50 Drill Bit to clean out the Mixing Chamber exit passage. Use a No. 55 Drill Bit to clean the inlet side holes of the Mixing Chamber taking care not to scratch the Mixing Chamber's polished surfaces.
 - ⑥ Re-assemble the Side Blocks and tighten Screws securely. Grease should appear at the tip of the Mixing Chamber. DO NOT open Air Switch on Gun because this will purge grease from the Gun. The grease should be allowed to remain in the Gun overnight.
7. Visually inspect entire system for leaks.
8. Turn OFF Air to System.

WARNING

Before removing Side Blocks make certain that both Gun Material Valves are in the fully OFF positions! Refer to Figures 4 and 5. If Material Valves are on when Side Blocks are removed, the Gun will quickly become encased in urethane!

WARNING

Point Gun Side Blocks down, away from all personnel. Existing fluid pressures could cause material to exit the Side Blocks with considerable force.

CAUTION

Do not bleed fluid pressure from the system.

OVERHAUL PROCEDURE

19875-00 (-01) Pumps
21835-00 Pumps

1. Dump pressure off system

WARNING

Be sure air and power are off to system. This is achieved by splitting side blocks off of gun, opening ball valves and purging materials into clean containers

2. Flush system side to be rebuilt with suitable solvent.

NOTE

This is optional, it makes the process easier.

3. Disconnect inlet fitting from the bottom of the pump.
4. Disconnect outlet fitting from the top of the pump.
 - a. Systems with Over Pressure Valve: remove DIN connector from switch, Phillips screw.
 - b. Remove Over Pressure Switch from fitting.

CAUTION

Do not immerse Over Pressure Valve in solvents externally. (Flushing will not affect).

5. Remove pump from base.
 1. Loosen and remove P/N 7729-10 Nylon Lock Nut from yoke.

(Older MX Systems), loosen allen screw screw in yoke, remove Hitch Pin, pull out Clevis Pin.

- b. Loosen and remove four bolts, P/N 9945-48C.

BREAKING DOWN PUMP

1. Loosen four nuts, P/N 7733-17 at the base of pump and remove, break loose, in a criss-cross pattern.
2. Remove Base, P/N P33-11 from Tie Rods, P/N 18289-00.

NOTE

On P/N 21835-00 pumps, watch out for APS-119, APS-128, & 19633-00. The 19633-00 will push these parts out. Observe which side of the APS-119 comes out, keep right side up for diagnostics.

3. Remove Valve Housing from the cylinder.
P/N UF-118 on 19875-00 pump.
P/N, 19634-00 on 21835-00 pump.
4. Using a rubber mallet, tap shaft out through the bottom of the cylinder, P/N 18219-00.
5. Remove cylinder, P/N 18219-00 from Pump Head, P/N 18227-00.
6. Remove Cup Adapter, P/N 21440-00 from Pump Head, P/N 18227-00.

Disassemble Sub-Assemblies

1. Cup Adapter, P/N 21440-00.
 - a. Remove Support Washer, P/N 18295-01.
 - b. Remove Seal, P/N 21595-00.
 - c. Remove Snap Ring, P/N 1005-02, Nylon Washer, P/N 21896-01, & Felt Wipers, P/N 21897-01.
2. Shaft Assembly:
 - a) Remove P/N 21598-00, Transfer Seat from P/N 21597-00, Transfer Housing. Watch for P/N APS-133, Ball and P/N 21803-00, Spring. The Ball is loaded with spring tension.
 - b. Remove FS-110, Piston Guide and P/N 21595-00 Pump Seal.

CLEANING

1. Thoroughly wash all parts in suitable solvent.
2. If parts have any build-up of hardened material, it is acceptable to polish parts with fine sand paper,(1200 grit) or steel wool(000).
3. It is recommended that the cylinder be honed with a fine grit bead honer,(P/N RK5-2).

INSPECTION

1. The Pump Cylinder, P/N 18219-00 inner wall should be smooth. No pitting or scarring should be seen. If slight scars show in the wall, they must not be able to be felt with a finger nail.
2. The Pump Shaft, P/N 21599-00 must not have any scoring, pitting, or build up of any debris on the shaft.
3. Set the Ball, P/N APS-133 in the Seat, P/N 21598-00 and hold up to a light. Observe for light between seat surface and the ball.

NOTE

If a large sliver of light shows, check for debris or scarring on Seat or Ball.

4. P/N APS-128 & P/N APS-119, repeat the above step.

NOTE

The APS-119 is reversible. You can use either side.

RE-ASSEMBLE

NOTE

All parts underlined are contained in repair kit.

2. Soak P/N 21897-01 in a light weight, non detergent oil, then install in P/N 21440-00.
3. Install P/N 21896-01, push down and install Snap Ring P/N 1005-02 in groove.
4. On bottom side of P/N 21440-00 install P/N 21595-00 in housings so that the lip faces out.

5. Lubricate and install O-Ring, P/N 13867-43 on bottom groove.
6. Install P/N 18295-01 with lip facing toward P/N 21595-00 seal.
7. Place P/N 21595-00 Seal and P/N FS-110 guide on P/N 21597-00. The lips of the Seal will face away from P/N FS-110.
8. Set P/N 21803-00 Spring in P/N 21597-00 Housing and set APS-133 Ball on Spring.
9. Apply blue lock-tite to the threads of P/N 21598-00 and install on P/N 21597-00. Tighten these two parts!
10. Lubricate and install two P/N 13867-49 O- Rings on P/N 18219-00 cylinder.
11. Using a light weight non-detergent oil, coat the seal on the shaft assembly and the walls of the cylinder, then install the shaft assembly into the cylinder, leave approximately 4" of the shaft exposed on the top side.
12. Install cylinder/shaft assembly into P/N 18227-00 Pump Head, careful not to cut O-Ring for Pump P/N 21835-00.
13. With the Pump Assembly upside down, (easy if clamped in a vise) install Foot Valve Housing P/N 19634-00.
14. Set P/N 19633-00 Spring in place and set P/N APS-128 Ball on Spring.
15. Lubricate and install P/N 13867-44 O-Ring in groove of P/N 19634-00.
16. Lubricate the outer edge of P/N APS-119 and set top of ball, square and center flats of P/N APS-119 and P/N 19634-00.
17. Gently set P/N P33-11 through P/N 18289-00 Tie Rods and push down square and firm until it sets down over cylinder O-Ring.
18. Continue holding P33-11 down, install (4) P/N 7734-12 Lock Washers and hand thread (4) P/N 7733-17 Nuts.
19. Tighten P/N 7733-17 in a criss- cross pattern until tight.

For 19875-00 Pumps:

1. Set UF-118 in cylinder.
2. Set P/N APS-128 in body.

3. Lubricate P/N 13867-44 and install in groove of UF-118.
4. Install P/N APS-119.
5. Gently set P/N P33-11 through P/N 18289-00 Tie Rods and push down square and firm until it sets down over cylinder O-Ring.
6. Continue holding P33-11 down, install 4 P/N 7734-12 Lock Washers and hand thread 4 P/N 7733-17 Nuts.
7. Tighten P/N 7733-17 in a criss- cross pattern until tight.
8. Lubricate P/N 21595-00 Seal (inside of P/N 21440-00 housing).
9. Gently push down over Pump Shaft P/N 21599-00 and set flush to P/N 18227-00 Pump Head.
10. Re-install pump in reverse order of removal.

Installation

Assembly Instructions

NOTE

The GlasCraft System is factory assembled. If any questions arise concerning air or electrical connections, please refer to illustrations located in the forward portion of this User Manual or contact your GlasCraft distributor.

Fluid Line Connection

The material hoses that bring Isocyanate and Polyol chemicals and the air from the machine to the gun should be connected as follows.

Required Tools:

Opened - end wrenches - 5/8", 3/4", 13/16"

1. Lay hoses out straight.
2. Couple hoses together with supplied union fittings and tighten finger-tight.
3. a. Hold crimp fitting hex (3/4"), and union fitting together, allowing the hose to hold it's natural line.
b. Using the appropriate wrench (A-side 3/4" / B-side 13/16") tighten swivel fitting to union, not allowing crimp fitting or union to turn. Repeat on opposite side of union.

This practice is required on all connection points.

- 1) Hose @ machine
- 2) Hose @ gun
- 3) Adding additional hose sections

4. Plug hoses together, The TRU-FLOW hose plugs are a twist-lock design.
 - a. Push plugs together.
 - b. Twist to lock position.

Once connections are made, tape connections well enough to keep plugs from coming undone, damaged, etc.

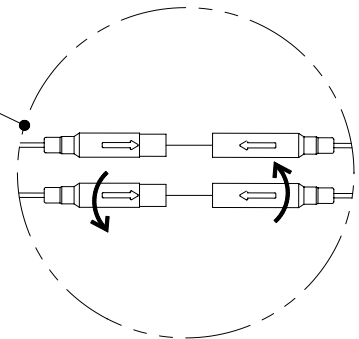
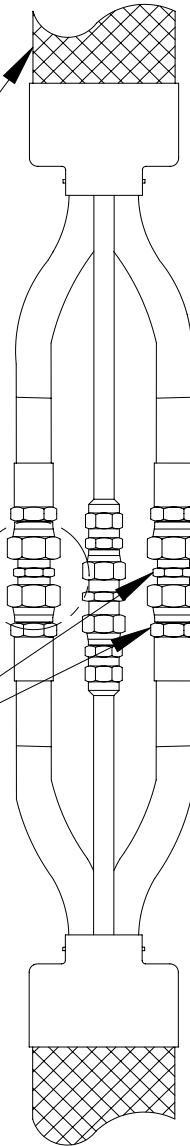

Installation

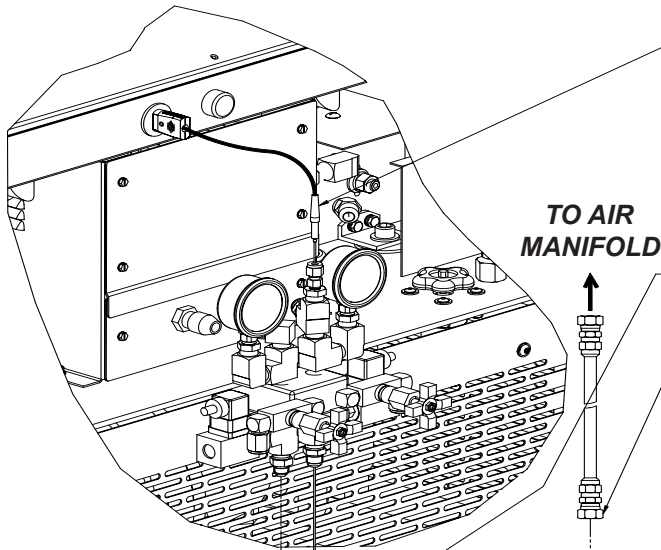

5. Install thermocouple at tee fitting.
 - a. Feed 12' line through hose.
 - b. Nut & Ferrules will lock into fitting.
 - c. Tighten nut 1-1/4 turns past finger tight.
 - d. Plug thermocouple into control box.

Note: When replacing thermocouple use kit p/n: 21214-01.

6. Connect hose assembly, to the front of the unit. The fittings are sized differently and will attach only one way. (match like sized fittings).

7. Connect supplied trigger air line to the air line on the hose assembly.

8. Connect whip hose p/n: 18006-00 to hose assembly, pn: 22023-01.

9. Connect jumper p/n: 22094-00 to plugs on hose assembly to complete circuit.

Note: Jumper not needed with 18006-01 heated whip hose.

10. a. Connect whip hose assembly to gun. The fittings are sized differently and will attach only one way.
b. Connect the air hose to gun.

11. The hose connections between the unit and gun should now be complete.

ALL FITTINGS SHOULD NOW BE TIGHT

CAUTION

Hose assemblies are constructed of durable, rugged materials, however they are not indestructible. To provide precisely controlled heated material, the hoses have electrical wiring wrapped between layers. Avoid dragging hoses over or around sharp, abrasive edges and corners. Exercising caution and common sense will give long, and reliable service from the hoses.

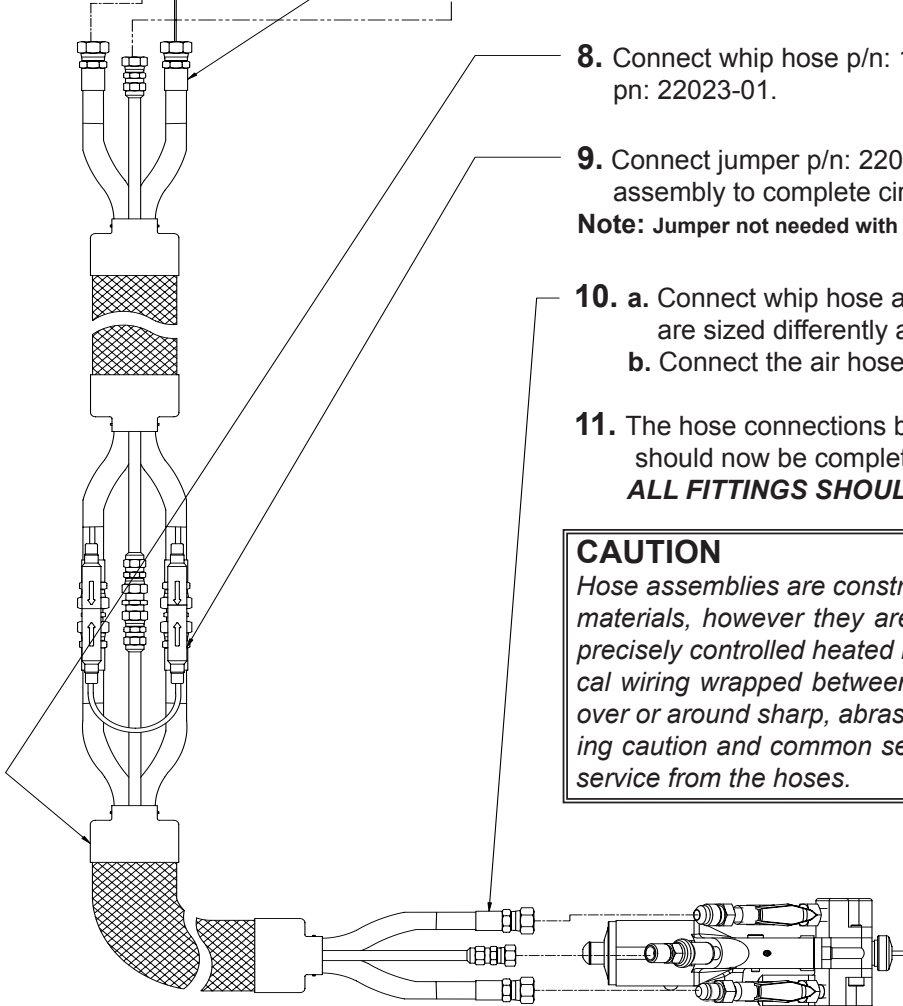

Installation

Optional Transfer Pump Installation

P/n: 17666-01

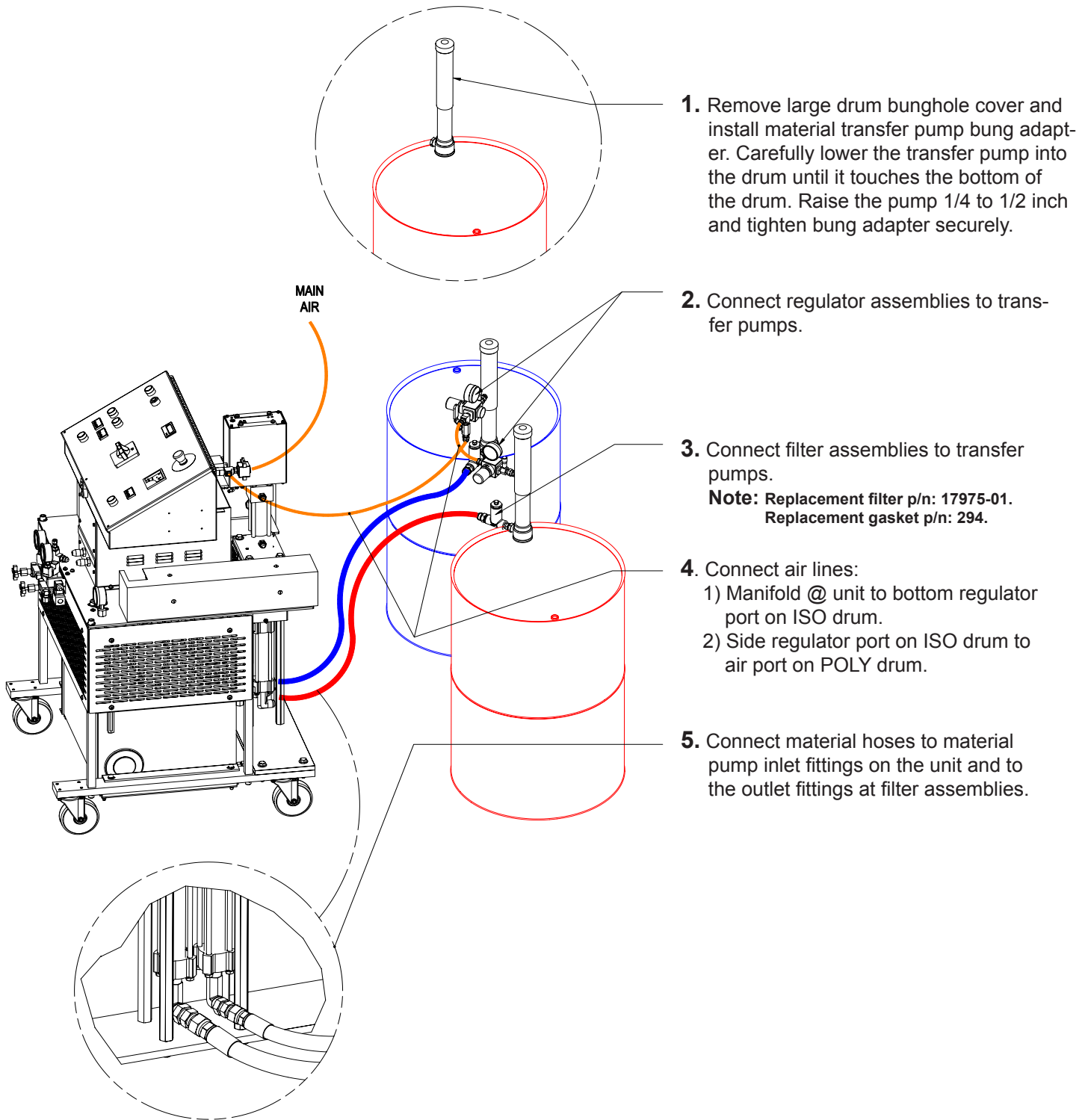

Optional Desiccant Dryer Kit

P/n: 23410-00 should be installed on the ISO material drum. Replacement cartridge p/n: 23409-00.

LIMITED WARRANTY POLICY

GLAS-CRAFT, INC. ("Glas-Craft") warrants to the original Purchaser of Glas-Craft manufactured equipment and parts, that all Glas-Craft manufactured equipment and parts will conform to their published written specifications and be free of defects in workmanship and material for a period of one (1) year from the original date of installation. Glas-Craft makes no warranty to anyone other than the original Purchaser.

If any Glas-Craft manufactured part or equipment is found to be defective in workmanship or material within the one-year period from the date of installation, as determined solely by Glas-Craft, Glas-Craft, in its sole discretion, will either repair or replace the defective part or equipment at Glas-Craft's cost, including freight charges both ways, or credit or refund the purchase price for the defective equipment or part.

A warranty claim will be honored only when:

1. Glas-Craft has been informed, in writing, of any such defect in workmanship or material within ten (10) days after discovery by the original Purchaser;
2. An official of Glas-Craft has issued a return authorization number; and
3. The claimed defective equipment or part has been returned to Glas-Craft by the original Purchaser, freight prepaid (with proper return authorization number(s) attached), to: Glas-Craft, Inc., 5845 West 82nd Street, Suite 102, Indianapolis, IN 46278, U.S.A.

This warranty shall not apply to any equipment or parts that have been altered or repaired by anyone other than Glas-Craft or to defects or damage resulting from improper installation, misuse, negligence, accident, or use not specified by Glas-Craft. This warranty shall not apply to any equipment where any parts or components were replaced by any parts or components not manufactured or supplied by Glas-Craft. The decision by Glas-Craft shall be conclusive and binding on Purchaser.

Glas-Craft does not warrant that any equipment or parts sold to Purchaser meet or comply with any local, state, federal, or other jurisdiction's regulations or codes. Glas-Craft does not warrant that any equipment or part sold to Purchaser, when used individually or in concert with any other part, equipment, device, component or process, does not infringe on any patent rights of any third party. Glas-Craft only warrants that it has no specific knowledge of any such infringement.

Glas-Craft makes no warranty as to any parts or equipment manufactured by others. Purchaser shall look solely and only to the manufacturer of such parts or equipment with respect to any warranty claims. Glas-Craft hereby assigns to Purchaser the original manufacturer's warranties to all such equipment and parts, to the full extent permitted.

THE AFORESAID WARRANTY IS IN LIEU OF ALL OTHER WARRANTIES, EXPRESS OR IMPLIED. SPECIFICALLY THERE ARE NO WARRANTIES OF MERCHANTABILITY OR FITNESS FOR A PARTICULAR PURPOSE, WHICH WARRANTIES ARE SPECIFICALLY DISCLAIMED.

Glas-Craft shall not be liable for any loss or expense resulting from damage or accidents caused by improper use or application of materials manufactured or sold by Glas-Craft or its distributors or agents.

UNDER NO CIRCUMSTANCES SHALL GLAS-CRAFT'S LIABILITY EXCEED THE AMOUNT PURCHASER PAID FOR THE CLAIMED DEFECTIVE EQUIPMENT OR PART. UNDER NO CIRCUMSTANCES SHALL GLAS-CRAFT BE LIABLE FOR INCIDENTAL OR CONSEQUENTIAL DAMAGES OR FOR LOST PROFITS.

No action arising from or relating to any goods manufactured by or purchased from Glas-Craft may be brought more than one (1) year after the cause of action accrues.

IF YOU HAVE AN EQUIPMENT PROBLEM...

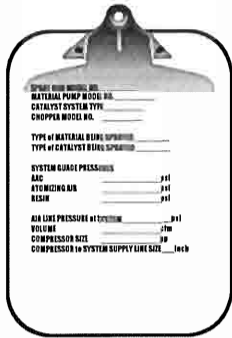

If you have a problem that requires Distributor or Glas-Craft Service Department help, gather the following information ***BEFORE*** you pick-up the telephone.



	Model No.	Serial No.
SPRAY GUN		
SYSTEM		
TYPE of MATERIAL BEING SPRAYED		
SYSTEM GAUGE PRESSURES		
ISO HEATER GAUGE		PSI
POLY HEATER GAUGE		PSI
MATERIAL PUMP AIR MOTOR		PSI
MAIN AIR LINE PRESSURE at SYSTEM		PSI
MAIN AIR LINE VOLUME		CFM
COMPRESSOR SIZE		HP
COMPRESSOR to SYSTEM SUPPLY LINE SIZE		INCHES

Have a general equipment or operation question? You can contact the Glas-Craft Service Department via E-Mail at gciservice@glascraft.com

FOR YOUR REFERENCE

DATE PURCHASED _____

DISTRIBUTOR _____

CONTACT _____

PHONE _____

Manufacturers of ...

*Fixed and Variable Ratio Systems and Equipment for Polyurethane, Polyurea
and Hybrid Materials Spray, Pour and Injection*

Micro II, Maxi II, Super Maxi, Mini II, MX, MX II, MH, MH II & MH III

SYSTEMS and EQUIPMENT for...

- *SPRAY, POUR & INJECT*
- *FIXED & VARIABLE RATIO SYSTEMS*
- *EQUIPMENT FOR POLYURETHANE FOAMS, COATINGS and
POLYUREAS*

...featuring the patented Probler and Probler II Spray/Pour Gun

LPA Series

*"Low Pressure, AIR ASSIST CONTAINMENT, Airless
External-Mix"*

**Gel-Coat, Wet-Out, & Chopper
Systems and Equipment**

INDy Series

"Internal-Mix Non-Atomized Dispense Systems"

**Gel-Coat, Wet-Out,
Chopper & Pressure Fed Roller
Systems and Equipment**

**For more information concerning any of these Glas-Craft products,
contact your local authorized Glas-Craft distributor, or**

Glas
Craft

DISPENSING EXCELLENCE

5845 WEST 82nd STREET, SUITE 102

PHONE (317) 875-5592

E-Mail gcisales@glascraft.com

INDIANAPOLIS, INDIANA 46278 U.S.A.

FAX (317) 875-5456

Web Site www.glascraft.com

Quality and Performance...
GENUINE GLAS-CRAFT

**Glas
Craft**
DISPENSING EXCELLENCE



www.glascraft.com

GC-1267

5845 WEST 82nd STREET
INDIANAPOLIS, INDIANA 46278 U.S.A.

Phone (317) 875-5592

Fax (317) 875-5456

E-Mail gcisales@glascraft.com

REVISED MAY 2004