

March 24, 2005

For Immediate Release

This service bulletin is for the Polyurethane & Polyurea product line(s).

This service bulletin covers the following products;

The digital Watlow 935 series controller

- 21356-00 used on MX & LX Models
- 21356-01 used on all following products;
Micro 2, Maxi 2, Super Maxi, Mini 3, MX 2, MH, MH 2, MH 3
- 21356-02 Replacement to the #21356-01 only

This bulletin is to provide information to distributors on ordering these part numbers. #21356-01 has been discontinued and #21356-02 is the replacement part. #21356-00 will continue to be available for a limited time.

While the physical size of this unit remains the same, do note replacing a 21356-01 with a 21356-02 in a system requires a minor change in the wiring which is detailed in this service bulletin.

These controllers must be programmed to work properly. Specific information is needed in order to program them prior to shipment from GlasCraft. The information required is as follows;

- 1) Equipment Model
- 2) Specify for "Primary" heater or "Hose" heat circuit
- 3) Fahrenheit or Celsius display

Function changes:

The #21356-00 & -01 required holding the "set" button while adjusting temperature set point.

The #21356-02 only requires holding the "up" or "down" button when adjusting temp, the "set" button continues to be the actual/set temp display. The "Infinity" button is inactive for this program.

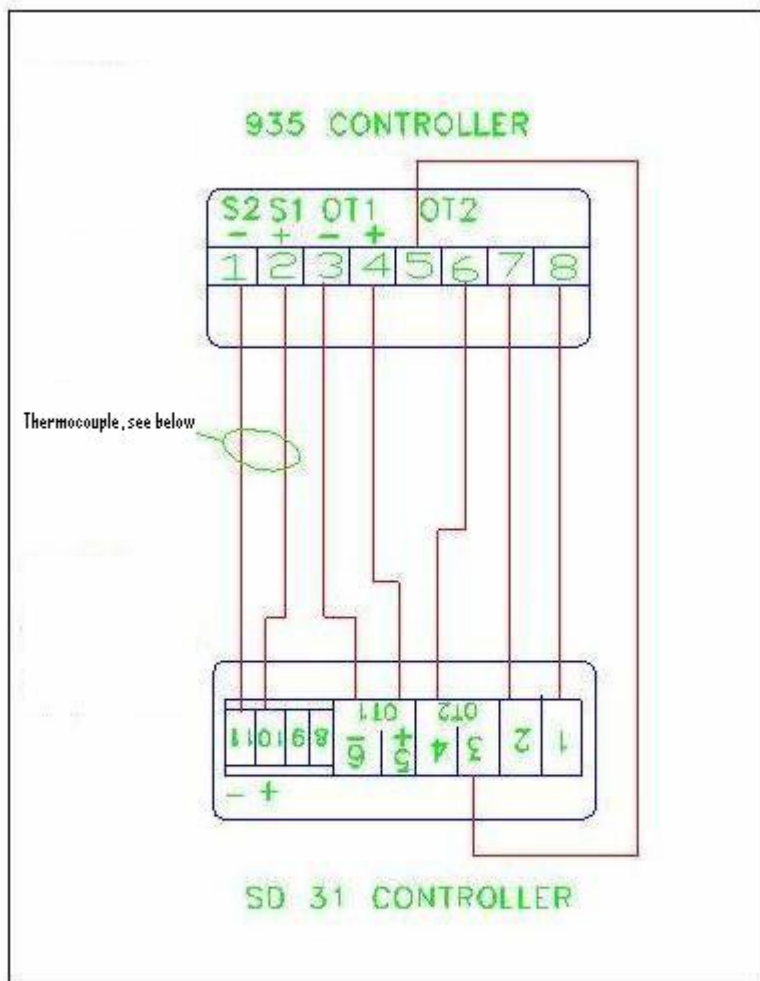

J T/C T T/C
 (+) WHT. (+) BLUE.
 (-) BLK. (-) RED.