

INSTRUCTIONS for TRU-FLOW PLUG KIT
MX II, MX II VR

Step one: Relieve pressure and flush system.

Step two: Make sure power is OFF!

Step three: Remove front cover exposing #6 wire attached to fluid blocks.
See figure 1

Step four: Disconnect wires from fluid blocks and cut the connectors off of both wires.
See figure 1

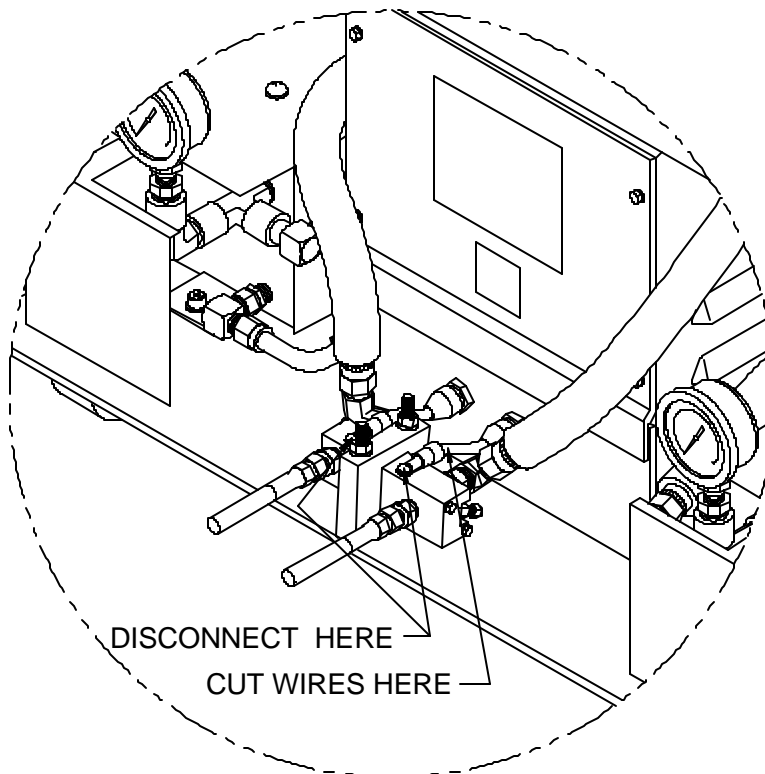

Figure 1

- Step five: A) Slide heavy-duty 1" heat shrink over each wire, push back away from ends.
B) Strip ends of #6 wire back approx. 1/4".
C) Apply **RED LOCTITE** to set screw of junction block and install wire into block, tighten down set screw on wire.
D) Slide heavy-duty heat shrink over junction block and shrink down with hair dryer.
E) Wrap individually with electric tape.

See figure 2

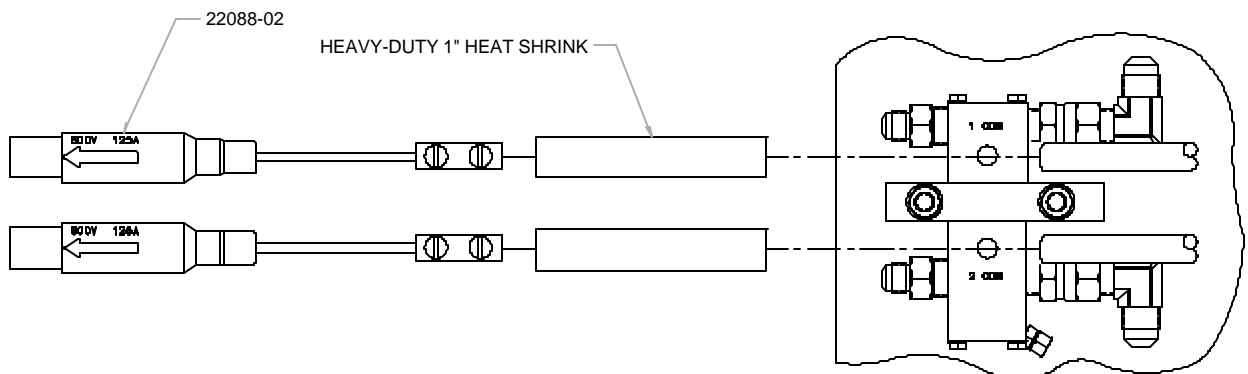

Figure 2

FIRST HOSE CONNECTION SYSTEM END

Step one: Remove clamps from both hoses. **See Figure 3**

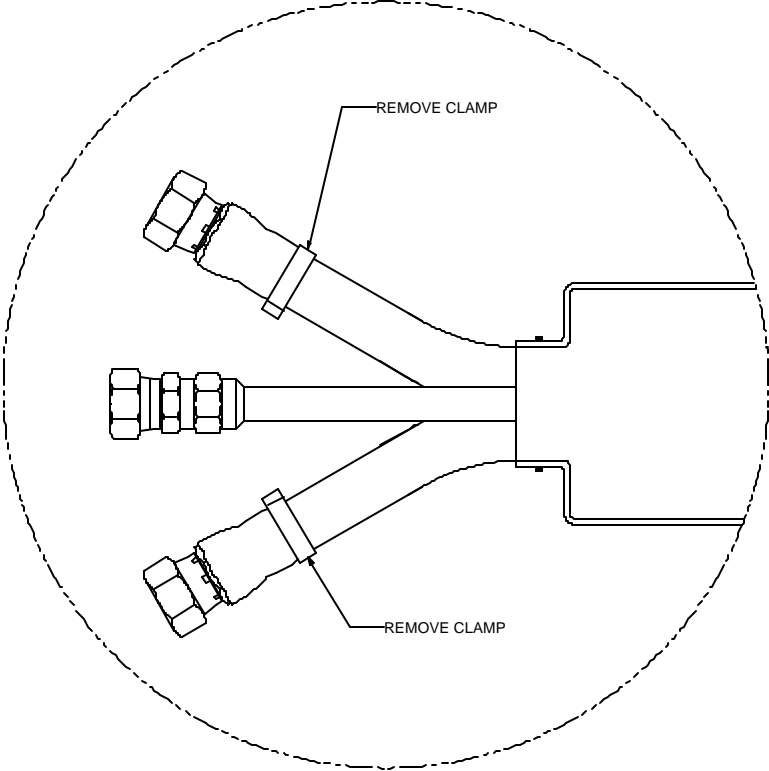

Figure 3

Step two: pull neoprene hose cover back 9" from the end of fitting exposing copper wire.

See Figure 4

NOTE: IF YOU HAVE AN OLD HOSE THE NEOPRENE MAY NOT PULL BACK. MEASURE BACK APPROX. 9" FROM THE END OF FITTING AND CUT THE NEOPRENE FROM HOSE.

Step three: Remove clamps and unattach the copper wire from the fittings.

See Figure 4

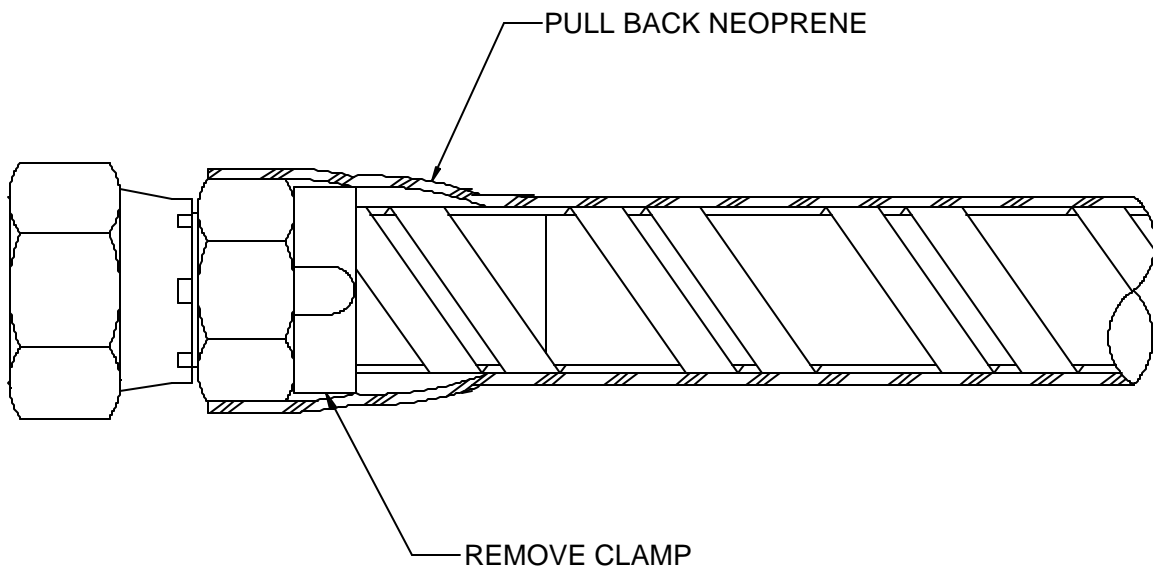

Figure 4

Step four: Unwrap copper from hose and tape to hose 9" from end of fitting.
See Figure 5

LEAVE EXCESS COPPER FOR CONNECTIONS DO NOT CUT

- Step five: A) Slide heavy-duty 1" heat shrink over each wire, push back away from ends.
B) Cut and fold both pieces of copper on top of each other and install into junction block approx. 7" from end of fitting.
C) Apply **RED LOCTITE** to set screw of junction block and tighten down set screw on copper.

See Figure 5

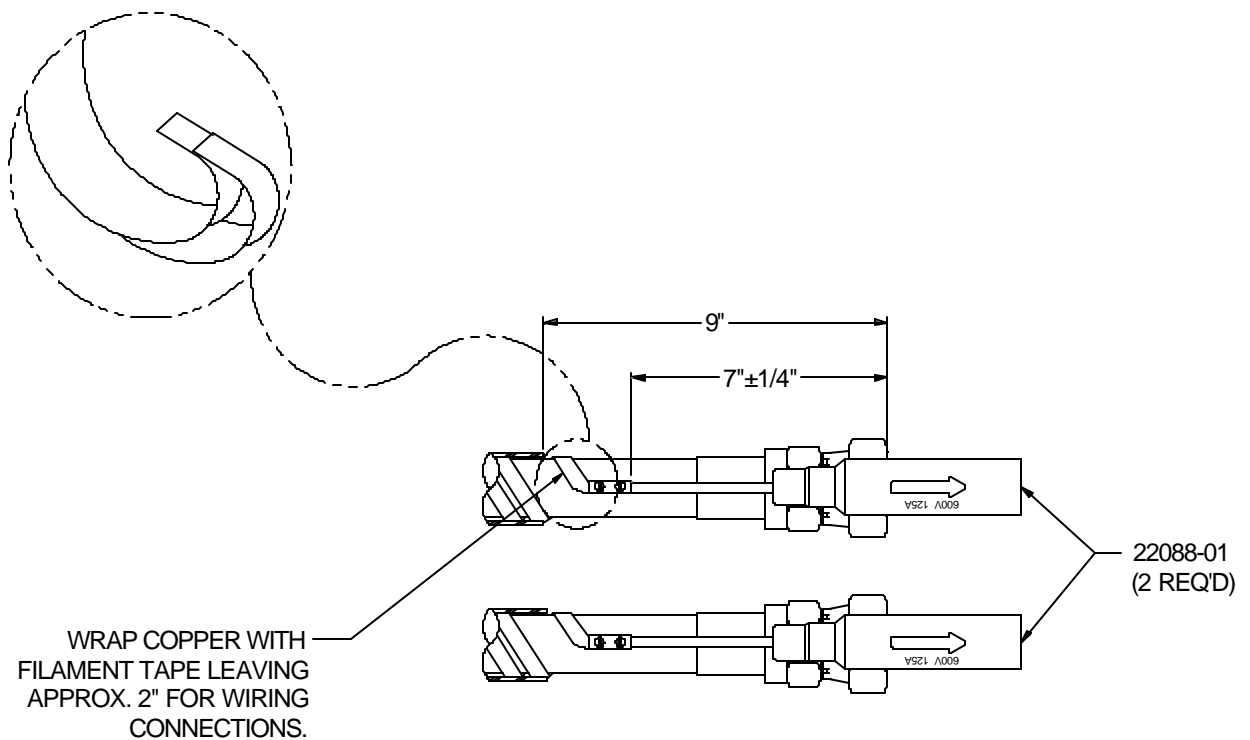

Figure 5

Step six: After connections have been made cover copper and butt splice connector with supplied heavy-duty 1" heat shrink and shrink.

See Figure 6

Step seven: pull neoprene cover back against butt splice connector. Cut off any excess.

See Figure 6

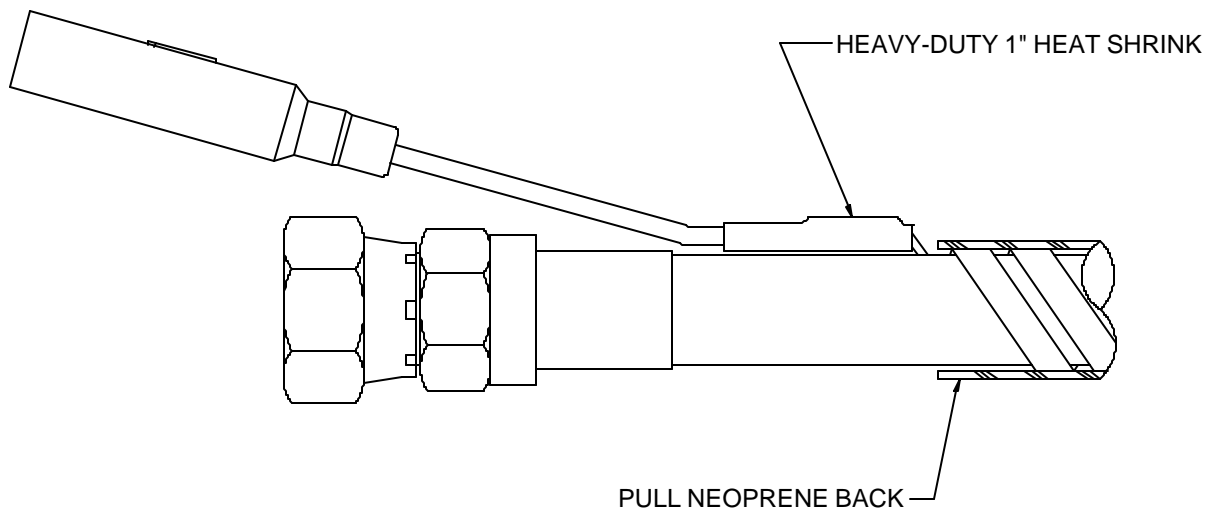

Figure 6

Step eight: Cover neoprene and butt splice connector with 5" of supplied thin heat shrink 18245-02 and shrink or use electric tape.

See figure 7

Step nine: A) Secure plug assembly to hoses with band clamps. 8612-01
B) Install 8612-01 on the backside of junction block to hold neoprene to hose assy.

See Figure 7

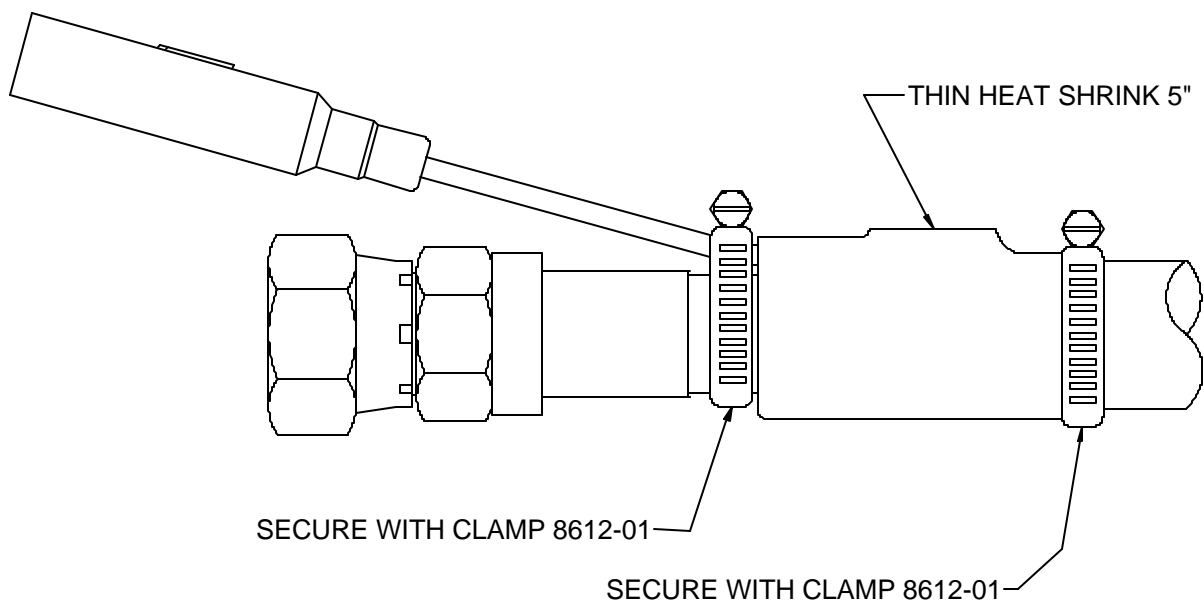

Figure 7

Finally repeat steps one through nine for each hose end.

BE SURE TO ALTERNATE 22088-01 & 22088-02 (MALE & FEMALE PLUGS)!

See Figure 8

NOTE: IF YOU ARE USING THE 18006-00 WHIP HOSE YOU WILL NEED TO USE 22094-00 JUMPER TO COMPLETE THE CIRCUIT.

See Figure 8

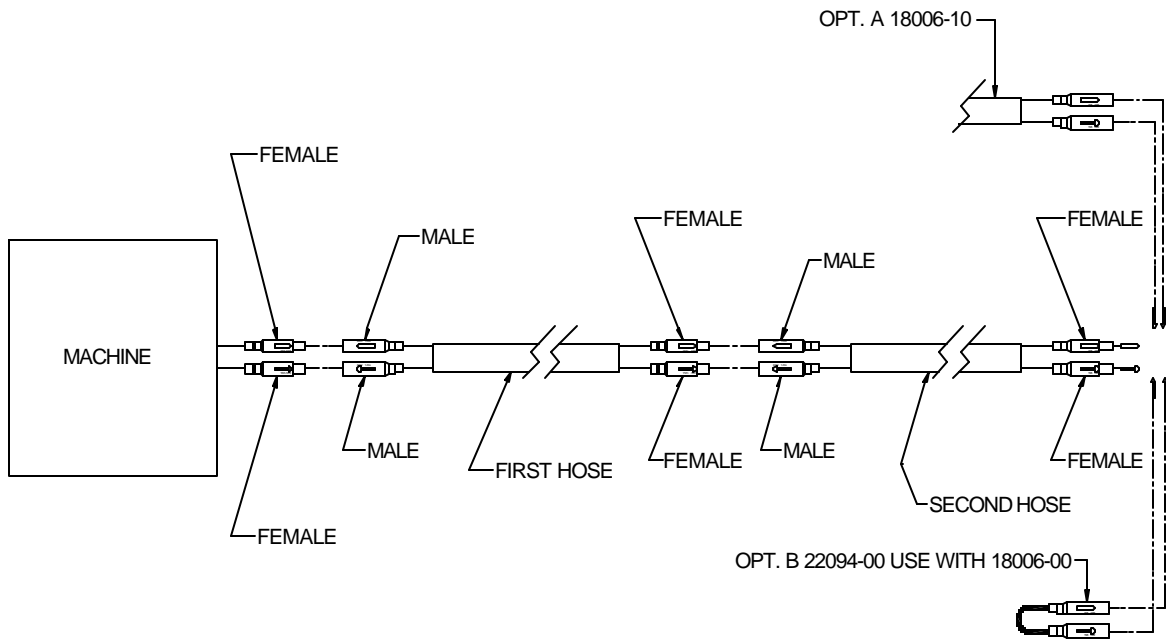

Figure 8

NOTE: Reattach all hoses, electrical connections, and fluid block cover before restarting machine.