



MX

Dispensing System

USER MANUAL



Glas-Craft, Inc.

5845 WEST 82nd STREET
INDIANAPOLIS, INDIANA 46278 U.S.A.

Phone (317) 875-5592
Fax (317) 875-5456
E-Mail sales@glascraft.com
Web www.glascraft.com

CE
CERTIFIED

An ISO 9001
Approved
Company

Specialized Dispensing
Equipment and Technology

CONTENTS

Introduction

ABOUT THIS MANUAL	1
RELATED MANUALS	1
TECHNICAL VIDEO TAPES	1

Parts & Illustrations

MX SYSTEM LIST	2
OPTIONS	2
SERVICE KITS	2
21800-00 MX SYSTEM ASSEMBLY	3
21800-00 MX SYSTEM ASSEMBLY	4
21800-00 MX SYSTEM DETAILS	5
21800-00 ISOLATION BLOCK ASSEMBLY	6
21820-00 CONTROL BOX ASSEMBLY	7
21820-00 CONTROL BOX DETAILS	8
21820-00 CONTROL BOX DETAILS	9
21820-00 CONTROL BOX DETAILS	10
21820-00 MX SYSTEM SCHEMATIC	11
21825-XX MX PROPORTIONING UNIT ASSEMBLY	12
21825-XX MX PROPORTIONING DETAILS	13
21835-00 FLUID SECTION ASSEMBLY	14
21875-00 ISO HEAT EXCHANGER ASSEMBLY	15
21875-00 ISO HEAT EXCHANGER DETAILS	16
21875-00 ISO HEAT EXCHANGER SCHEMATIC	17
21885-00 POLY HEAT EXCHANGER ASSEMBLY	18
21885-00 POLY HEAT EXCHANGER DETAILS	19
21885-00 POLY HEAT EXCHANGER SCHEMATIC	20
21404-35 HOSE ASSEMBLY	21
17254-01 PROBLER SPRAY GUN	22

Safety

SAFE HANDLING AND USE OF SPRAY EQUIPMENT	23
--	----

Installation

ASSEMBLY INSTRUCTIONS	26
AIR SUPPLY CONNECTION	26
ELECTRICAL CONNECTION	26

Operation

PRE-OPERATION CHECK LIST	27
INITIAL START-UP PROCEDURE	
FILLING THE SYSTEM	27
OVER PRESSURE	
SYSTEM PROTECTION	28
OVER PRESSURE	
PROBLEM CORRECTION	29
CONTROL PANELS	29
PROPORTIONING PUMP	30
AIR MOTOR	30
SYSTEM SHUT- DOWN	31

Overhaul Procedure

BREAKING DOWN PUMP	32
DISASSEMBLE SUB-ASSEMBLIES	32
CLEANING	33
INSPECTION	33
RE-ASSEMBLE	33
FOR 19875-00 PUMPS	34

Limited Warranty Policy

35

Notes

36

If You Have an Equipment Problem

38

Added Supplement (AIR MOTOR)

OPERATION
INSTALLATION
MAINTENANCE

INTRODUCTION

About This Manual

Before operating, maintaining or servicing any **Glas-Craft** system, read and understand all of the technical and safety literature provided with **Glas-Craft** products. If you do not have the manuals and safety literature for your **Glas-Craft** system, contact your **Glas-Craft** distributor or **Glas-Craft, Inc.**

In this **Glas-Craft** technical and safety publication, the following advisories will be provided where appropriate:

NOTE

Is information about the procedure in progress.

CAUTION

Is imperative information about equipment protection.

WARNING

Is imperative information about personnel safety.

The information in this document is intended only to indicate the components and their normal working relationship typical use. Each assembly should be directed by a **Glas-Craft** distributor or made from the **Glas-Craft** assembly instructions provided.

This manual provides information for the assembly, operation, maintenance and service of this **Glas-Craft**

product as used in a typical configuration. While it lists standard specifications and procedures, some deviations may be found.

In order to provide our users with the most up-to-date technology possible, we are constantly seeking to improve products. If technological change occurs after a product is on the market, we will implement that technology in future production and, if practical, make it available to current users as a retrofit, up-date or supplement. If you find some discrepancy between your unit and the available documentation, contact your **Glas-Craft** distributor to resolve the difference. **Glas-Craft, Inc.** reserves the right to change or modify this product as it deems necessary.

Careful study and continued use of this manual will provide a better understanding of the equipment and process, resulting in more efficient operation, longer trouble-free service and faster, easier trouble-shooting.

Related Manuals

For detailed component installation, operation and maintenance, refer to the following component manuals:

	COMPONENT	MANUAL NUMBER
17254	Probler Gun	GC-1023

PARTS & ILLUSTRATIONS

Includes

21800-00	MX FOAM SYSTEM
	* 6" AIR MOTOR, 1 PHASE, 200/240 VAC, 50/60 HZ., 60 AMP
17254-01	PROBLER GUN ASSEMBLY
	* W/ ROUND SPRAY MIXING CHAMBER
21404-35	HEATED HOSE ASSEMBLY, 35 FT.
21825-611	PROPORTIONING UNIT ASSEMBLY
21875-00	ISO HEAT EXCHANGER ASSEMBLY
21885-00	POLY HEAT EXCHANGER ASSEMBLY
59934-04	DIOCTYL PHTHALATE, 1 QT.
17661-03	GUN SERVICE KIT
21845-00	PUMP FLUID SECTION SERVICE KIT (TWO SUPPLIED)
	18467-01 FLUID FILTER (TWO SUPPLIED)
17195-00	MIXING CHAMBER REMOVAL TOOL
	USER MANUALS

Options

21403-35	HIGH HEAT EXTENSION HOSE ASSY., 35 FT. > maximum Hose length, 210 FT.
----------	--

Service Kits

17661-03	GUN SERVICE KIT
----------	-----------------

21800-00 MX SYSTEM ASSEMBLY

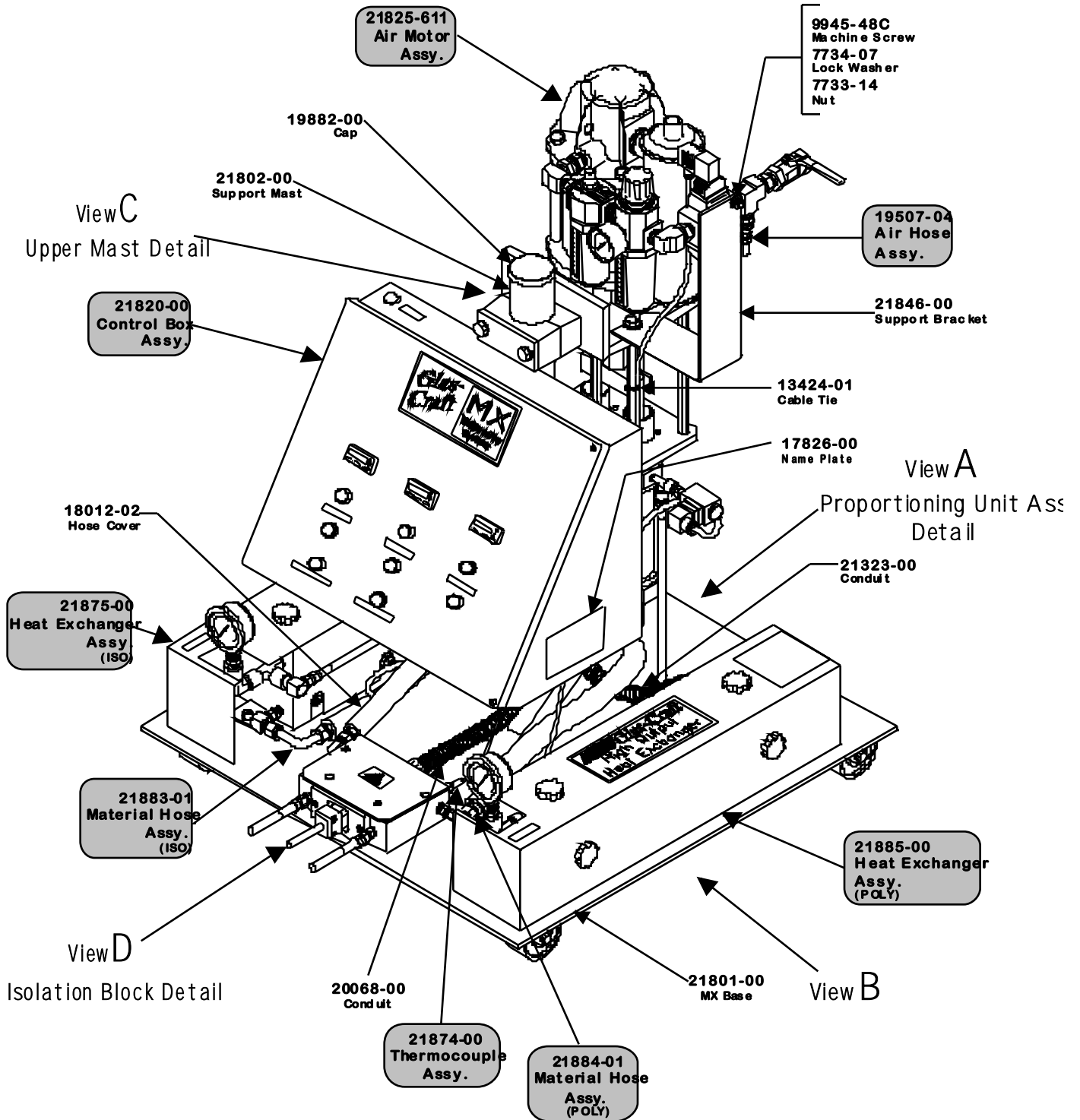

21800-00 MX SYSTEM ASSEMBLY

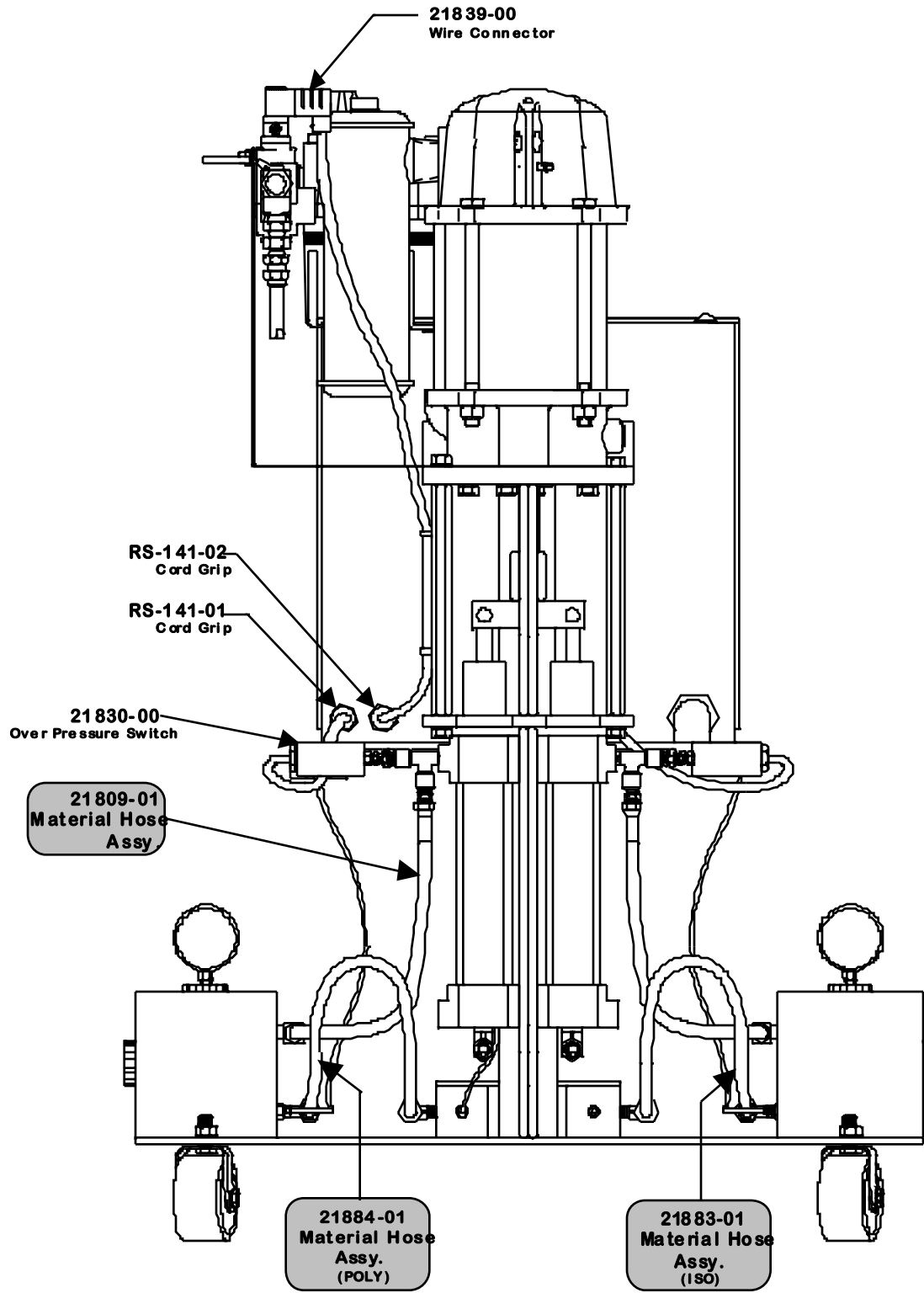

REAR VIEW

REVISED 10/9

21800-00 MX ASSEMBLY DETAILS

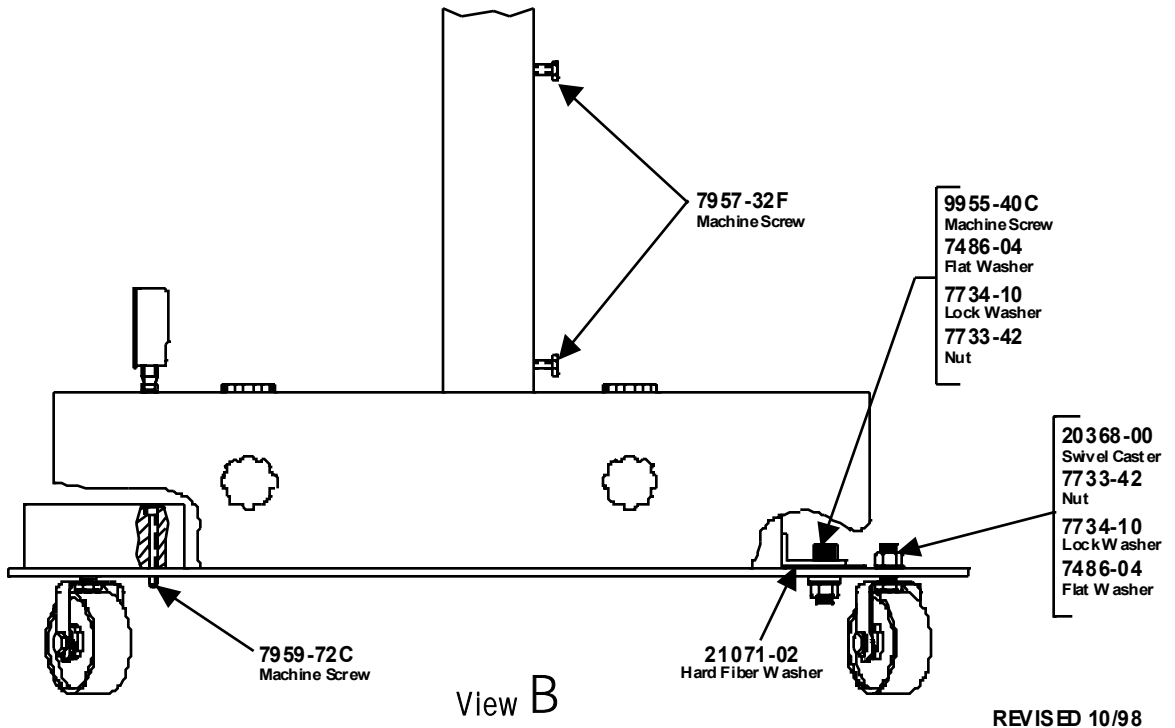
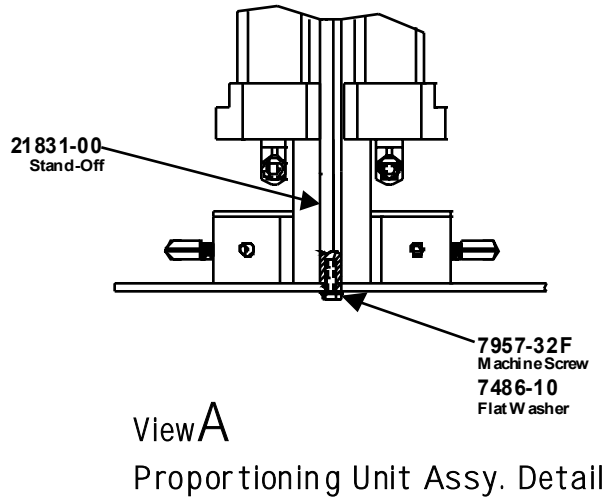
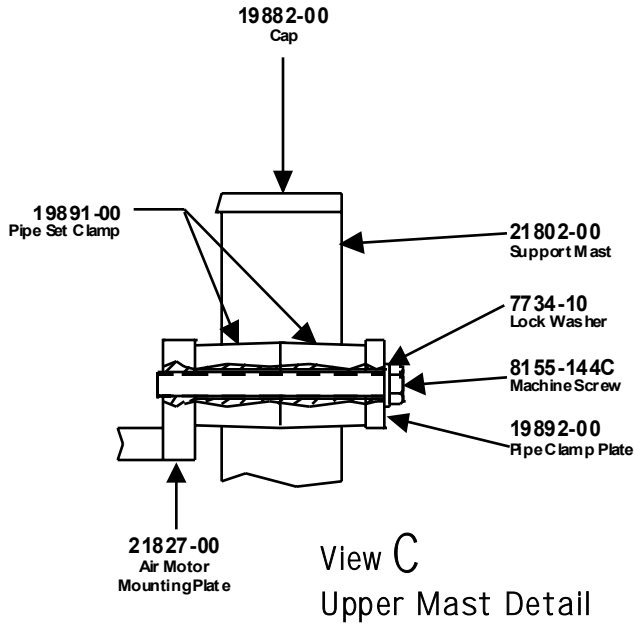

REVISED 10/98

21800-00 ISOLATION BLOCK ASSEMBLY

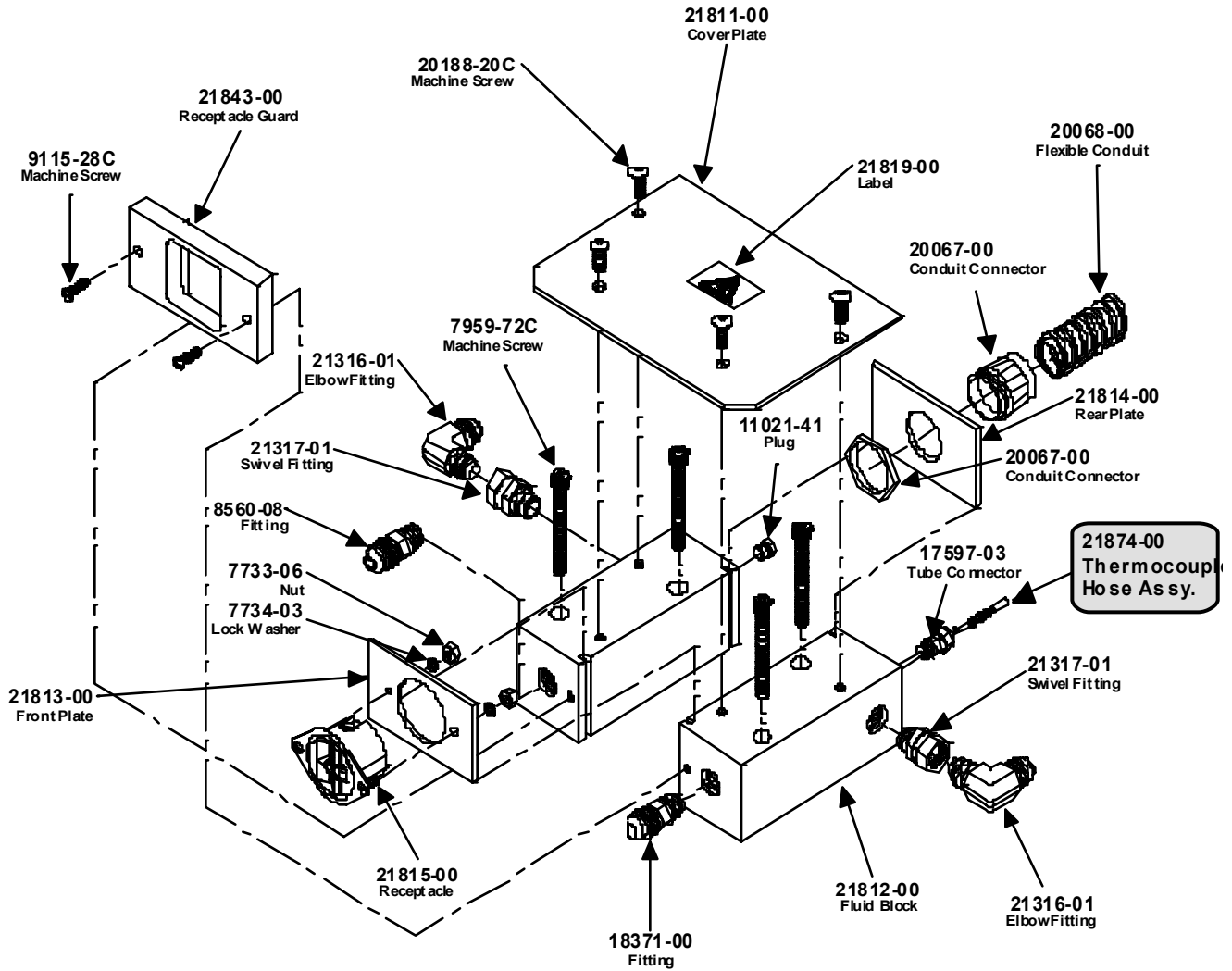

REVISED 4/00

21820-00 CONTROL BOX ASSEMBLY

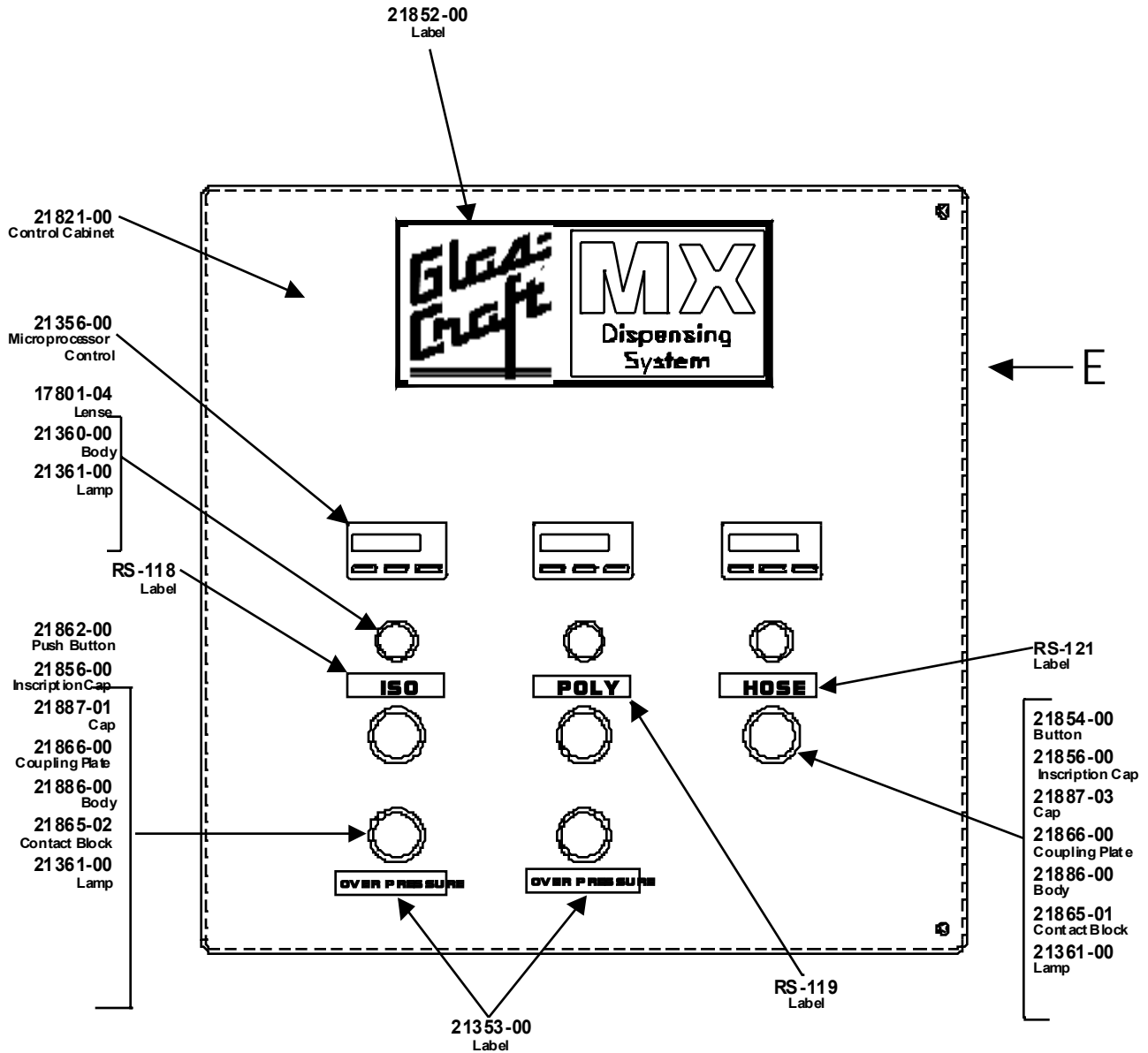

REVISED 8/99

21820-00 CONTROL BOX DETAILS

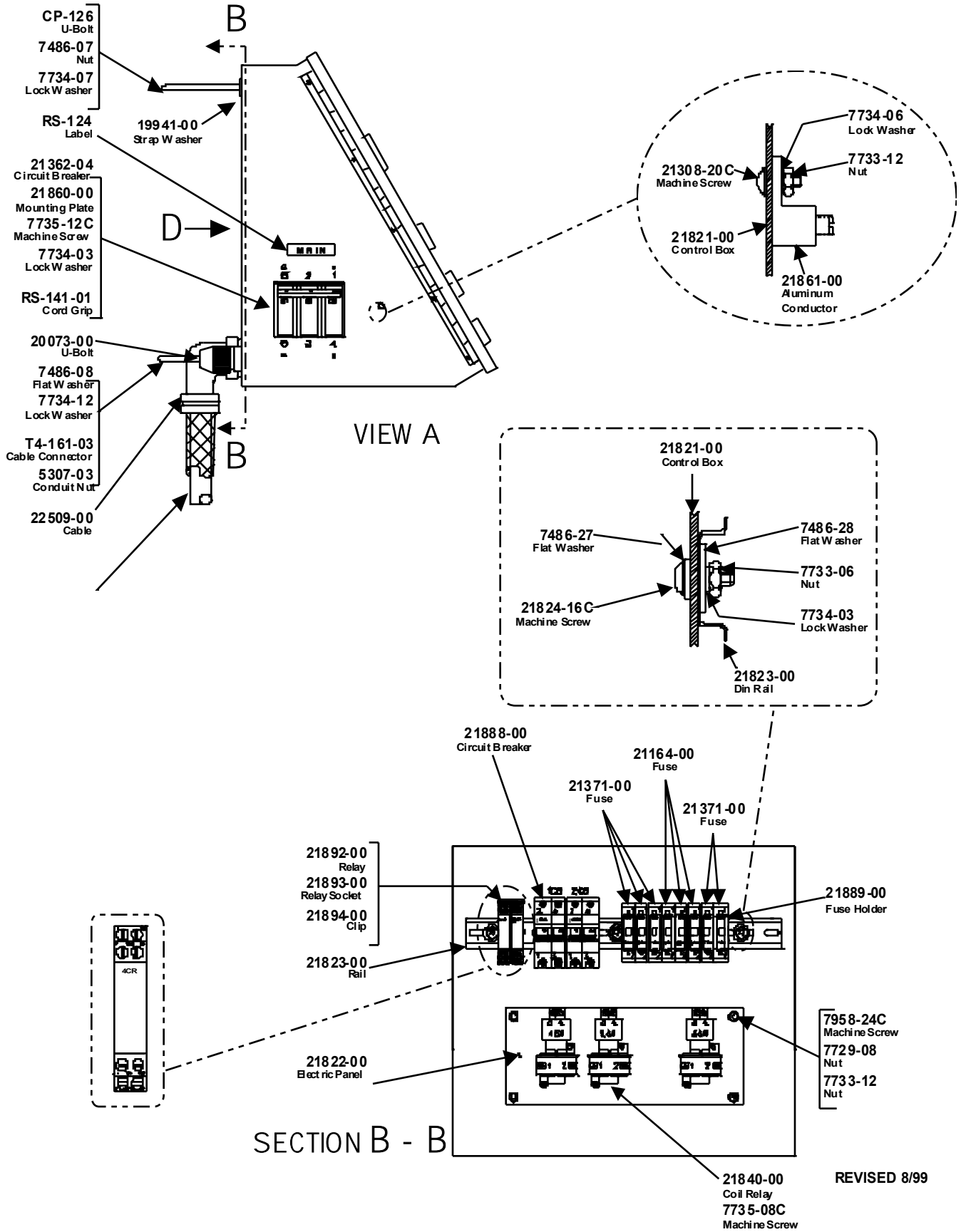

21820-00 CONTROL BOX DETAILS

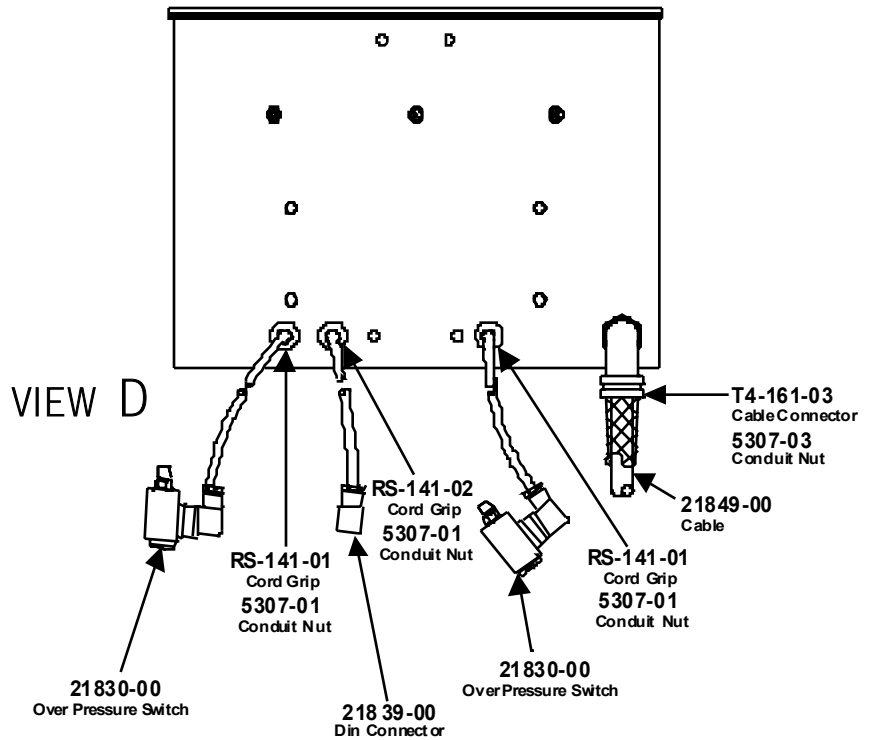
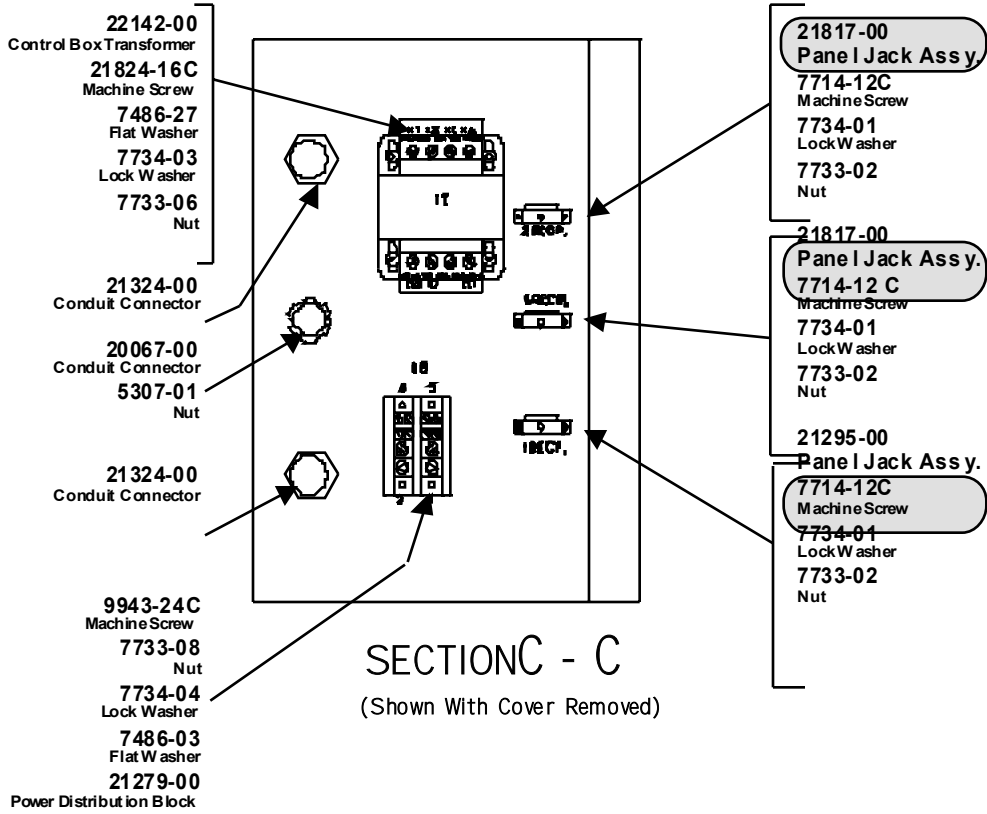

21820-00 CONTROL BOX DETAILS

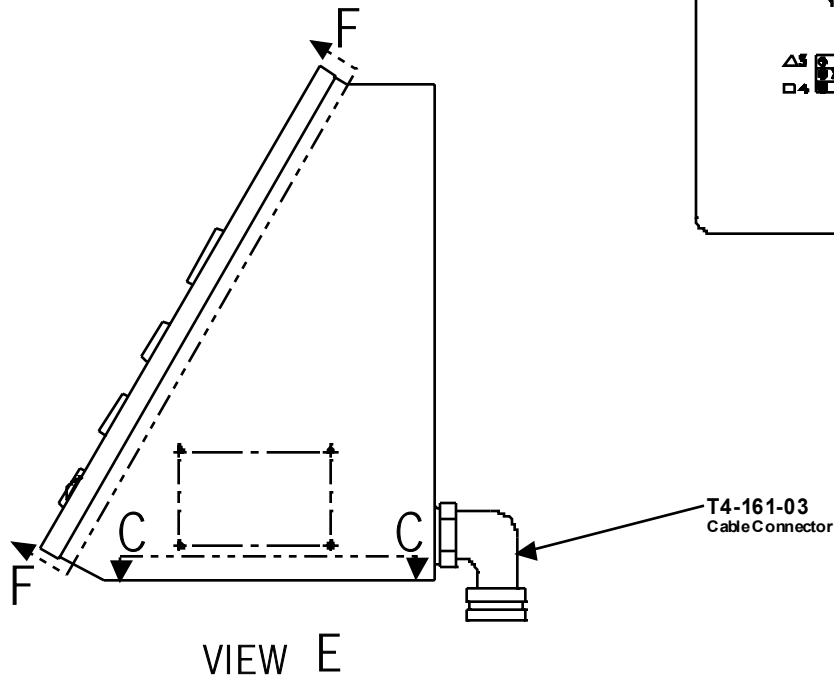
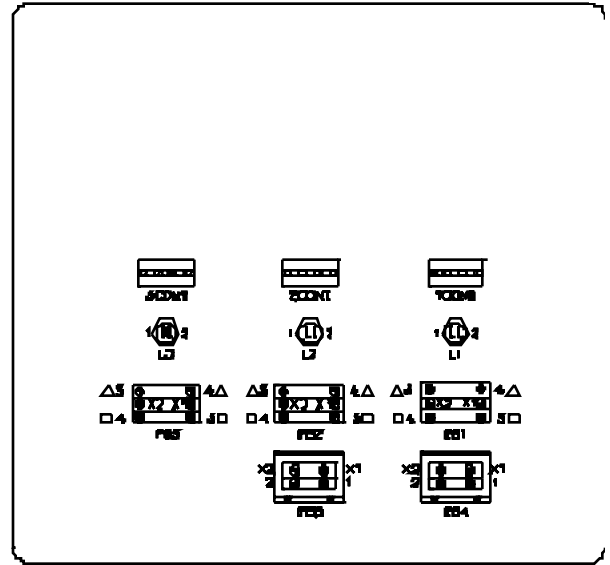
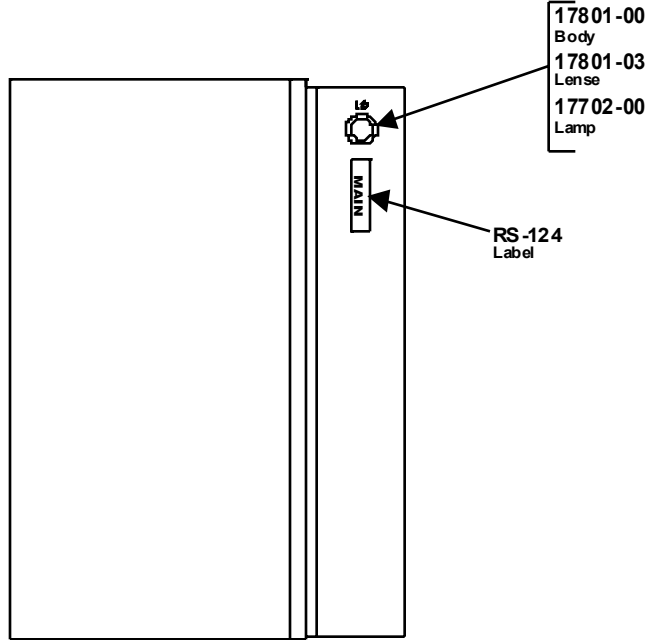

21820-00 MX SYSTEM SCHEMATIC

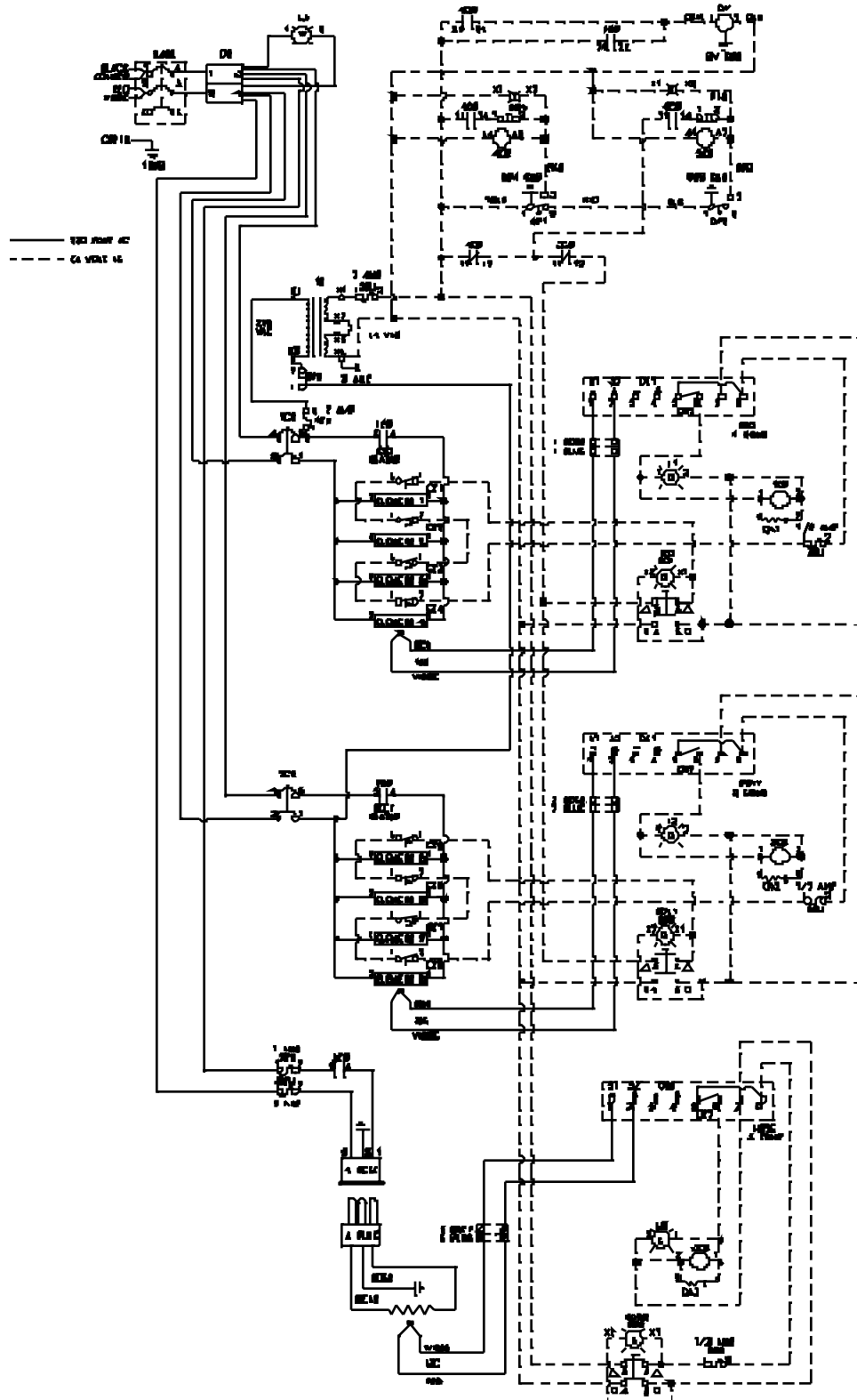

21825-XX MX PROPORTIONING UNIT ASSEMBLY

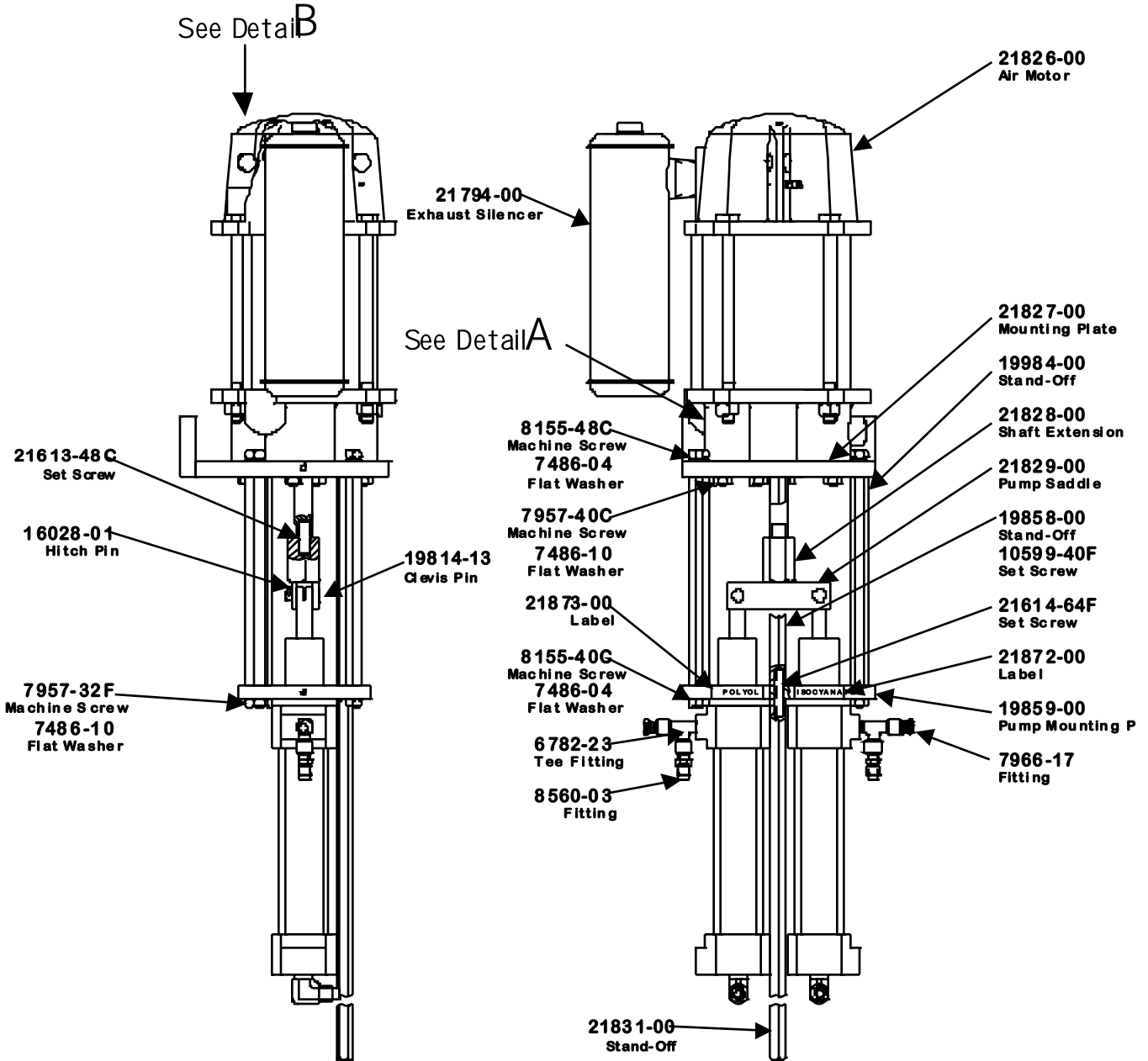

REVISED 6/98

21825-XX MX PROPORTIONING DETAILS

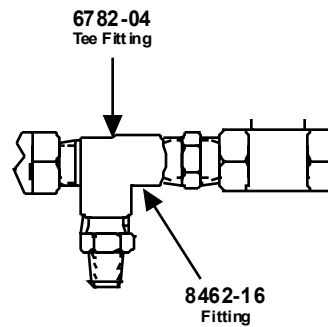
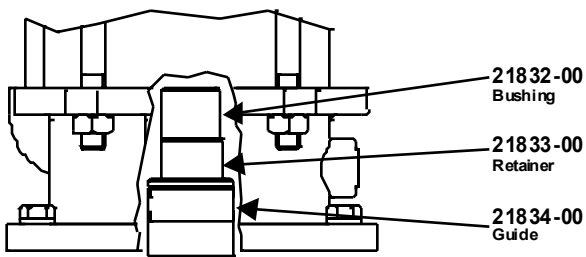
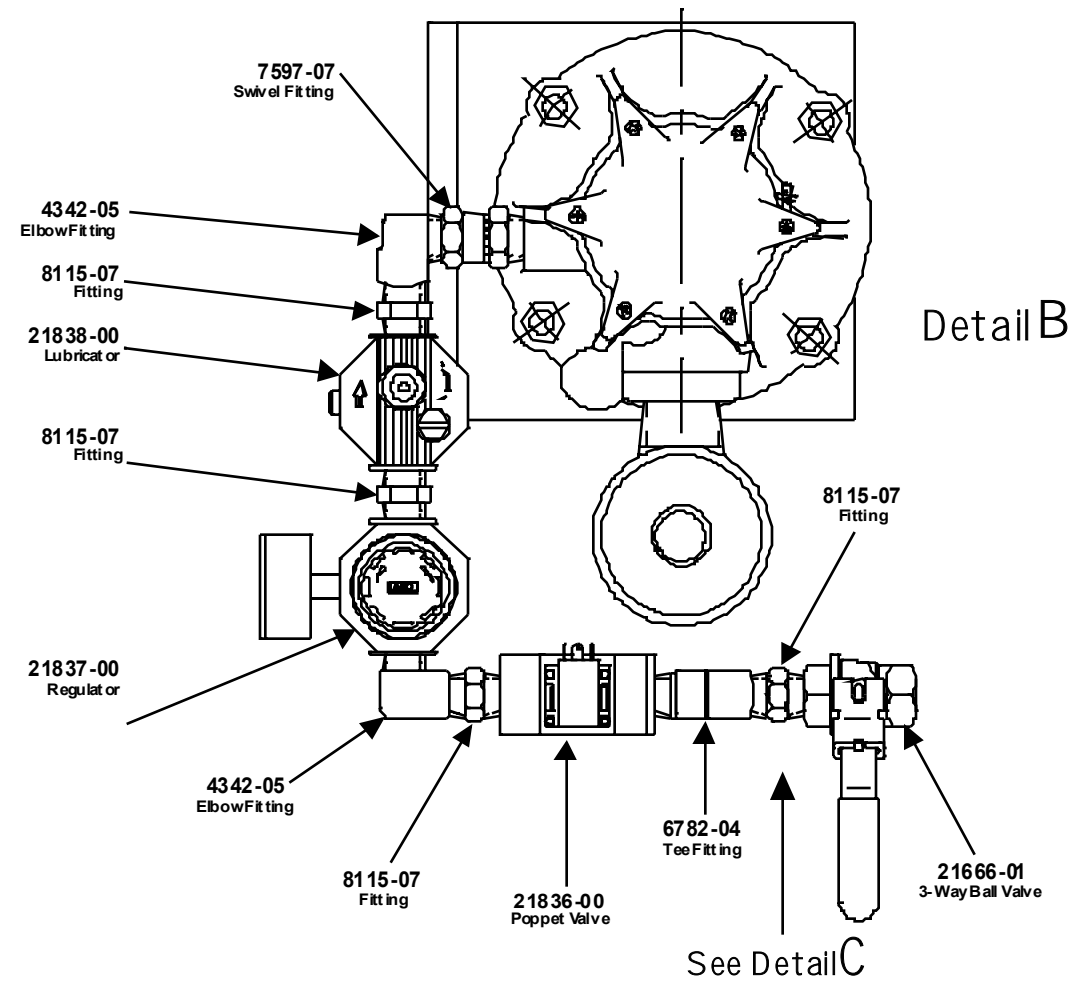

REVISED 6/98

21835-00-00 FLUID SECTION ASSEMBLY

RATIO: 1:1

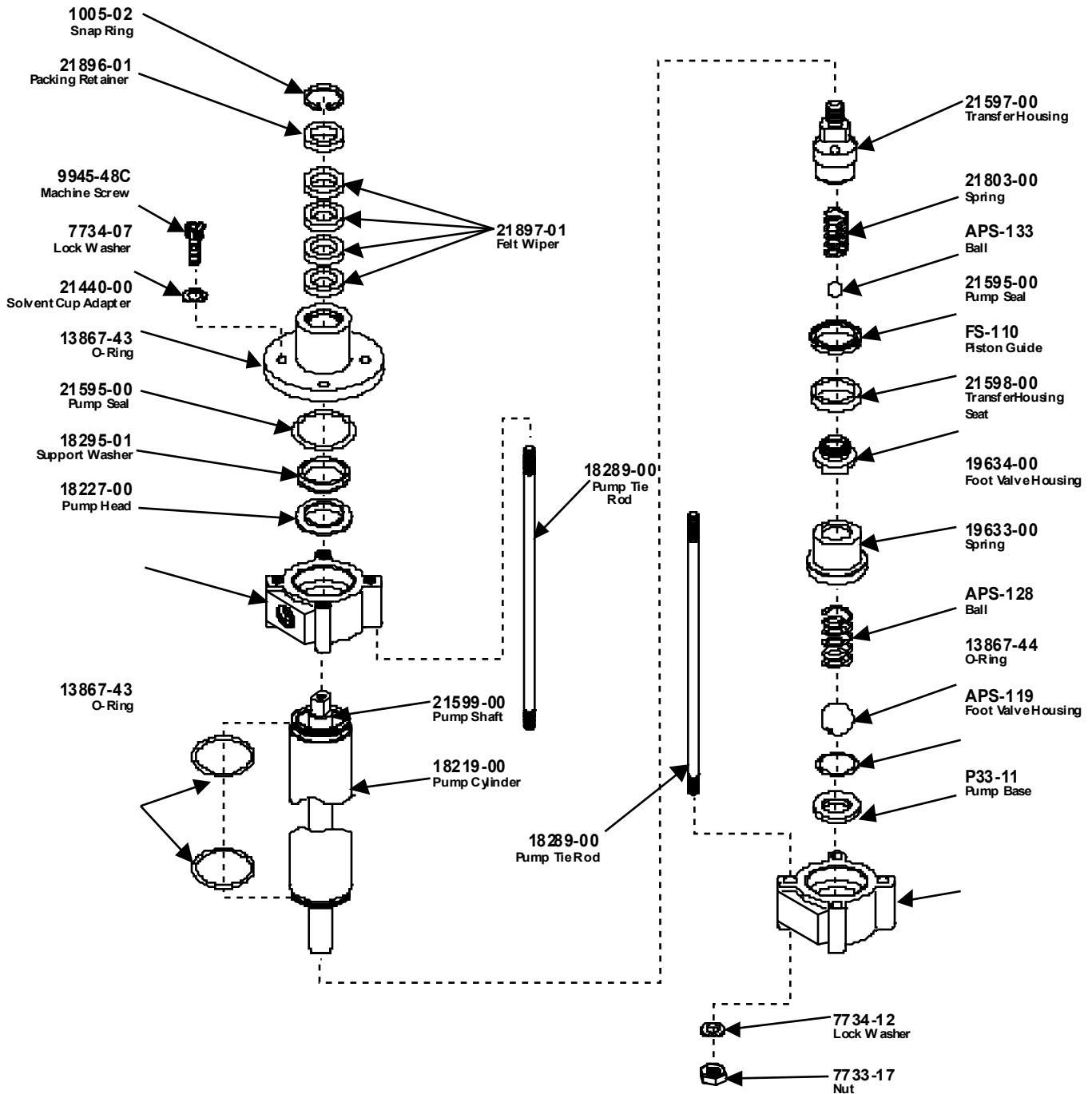

REPAIR KIT: 21845-00

21875-00 ISO HEAT EXCHANGER DETAILS

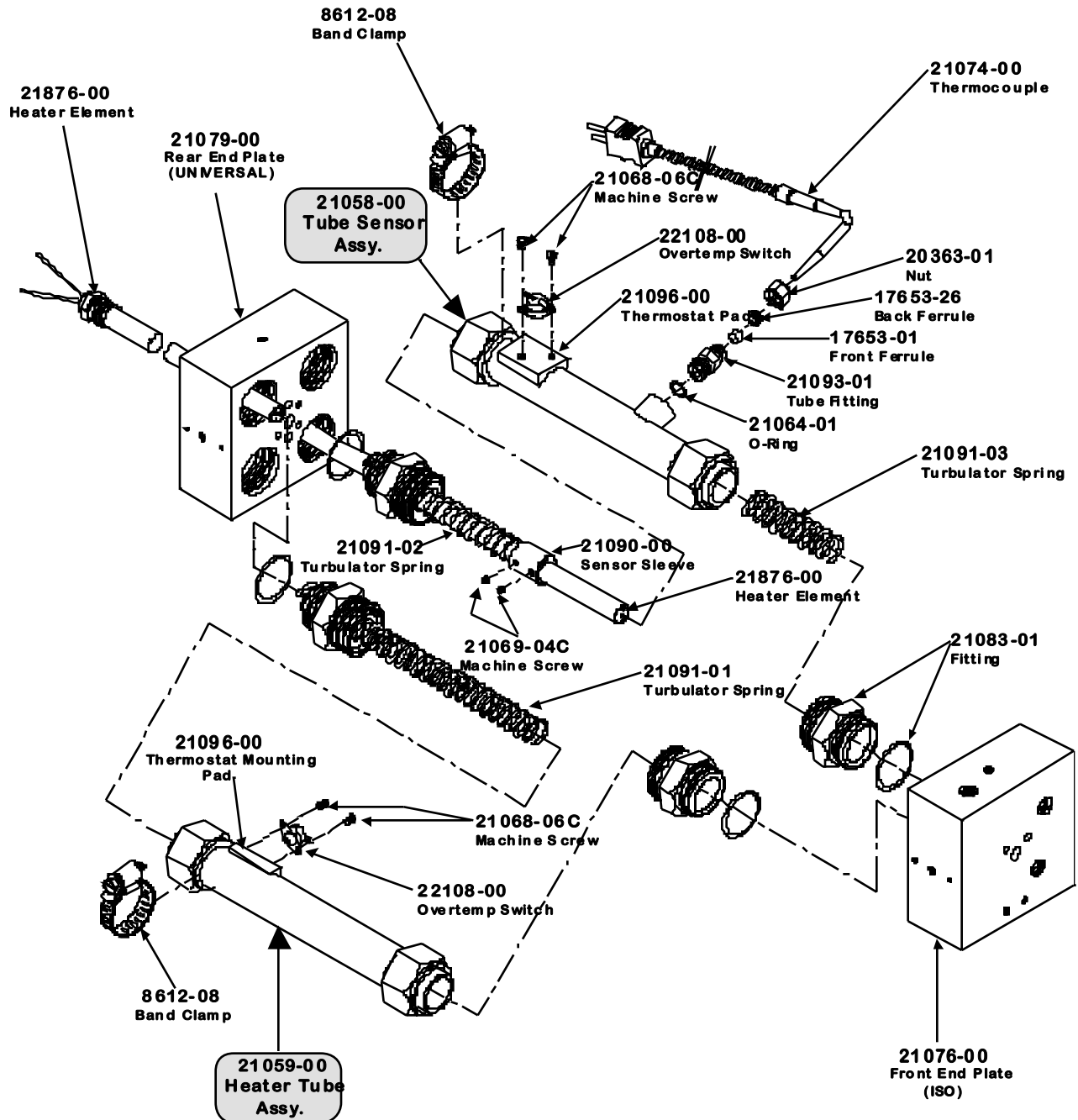

21875-00 HEAT EXCHANGER SCHEMATIC

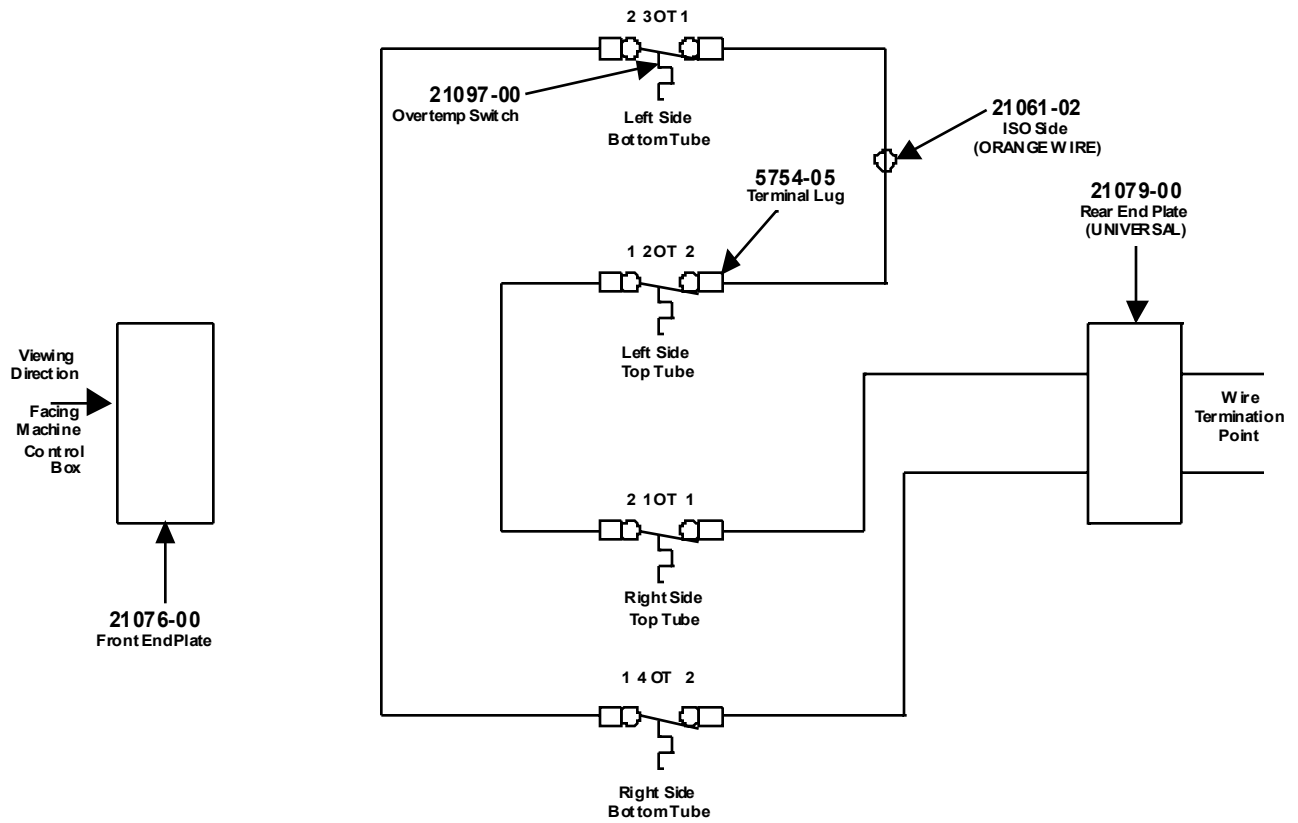

21885-00 POLY HEAT EXCHANGER ASSEMBLY

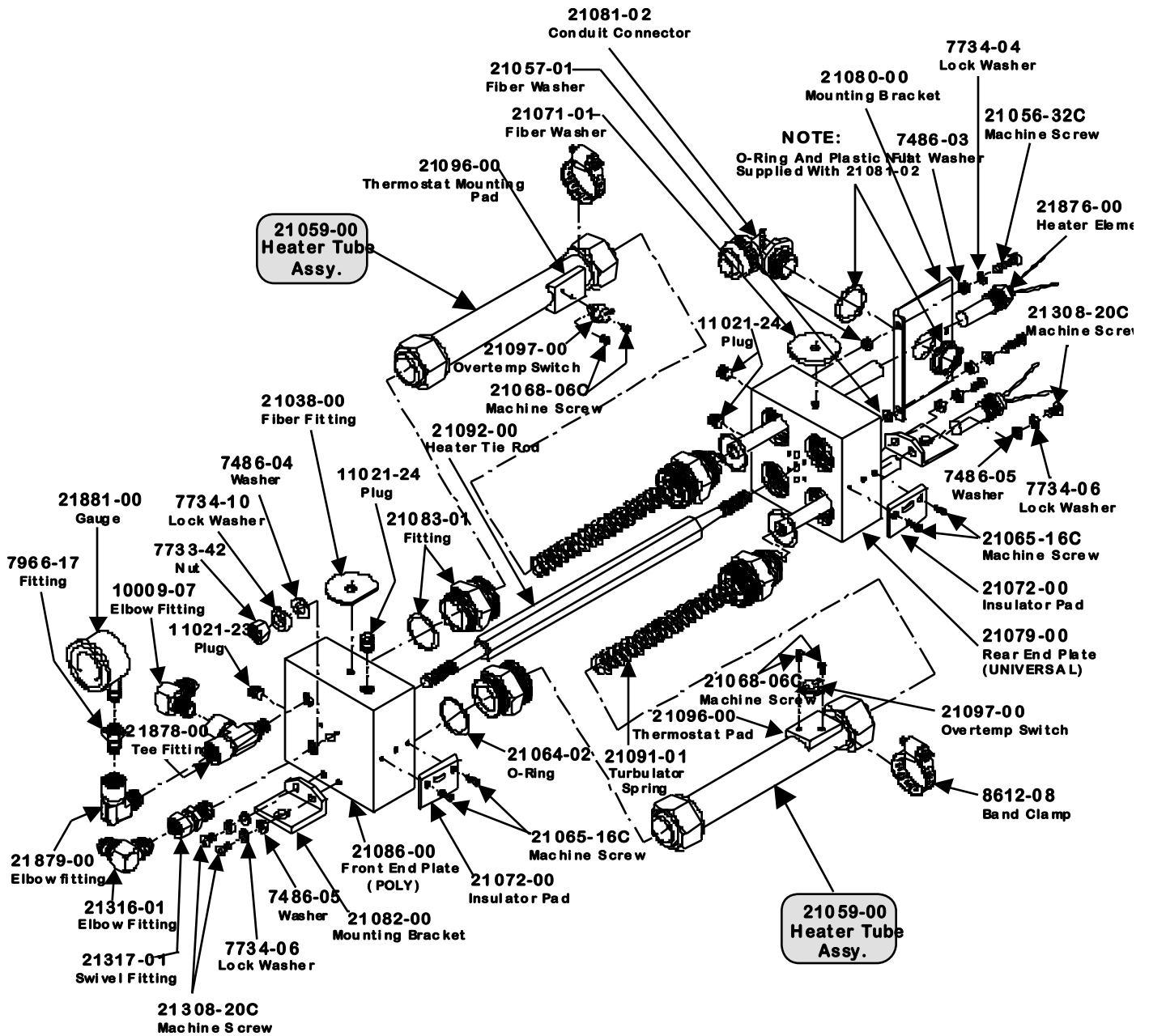

21885-00 POLY HEAT EXCHANGER DETAILS

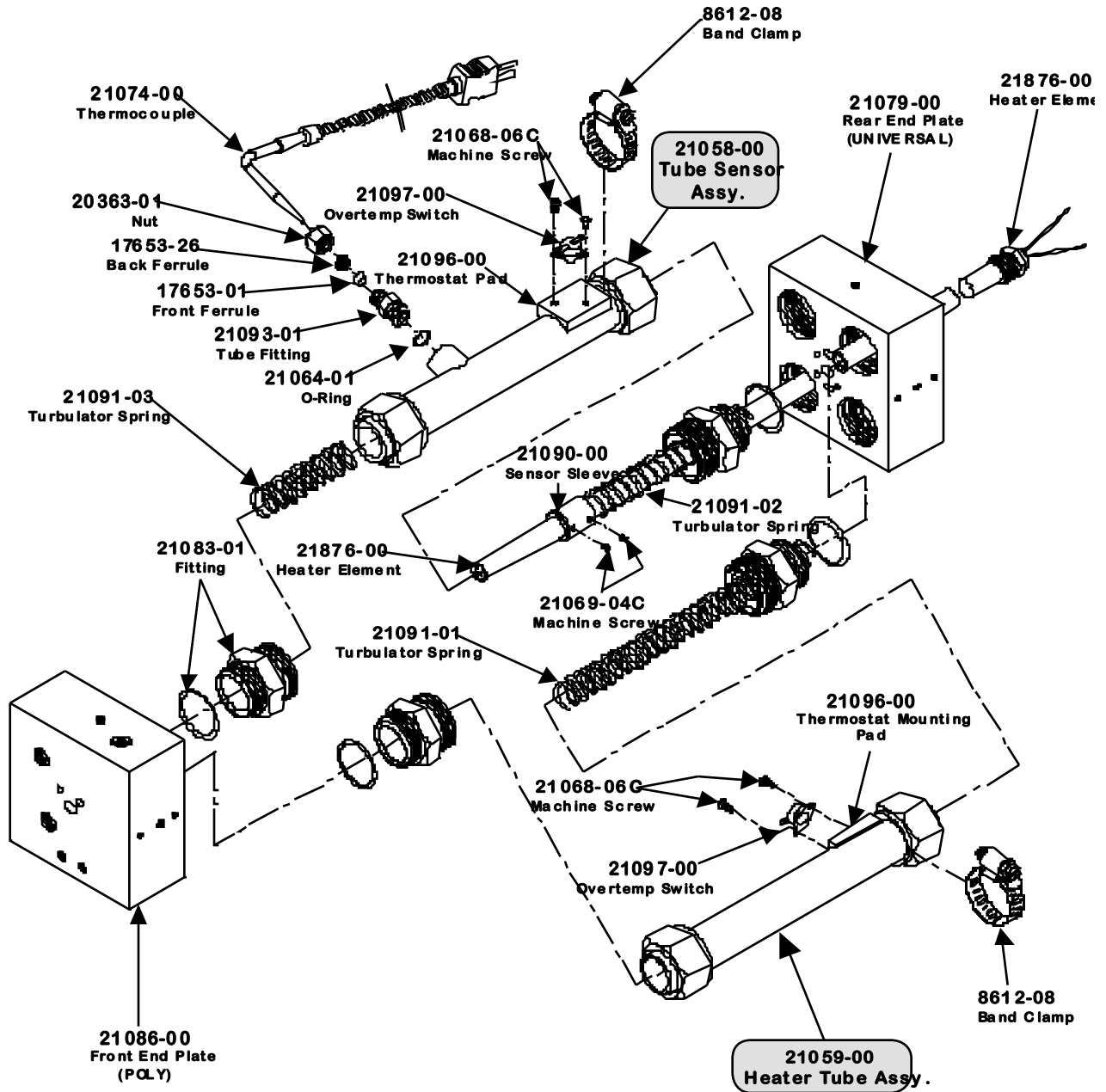

21885-00 POLY HEAT EXCHANGER SCHEMATIC

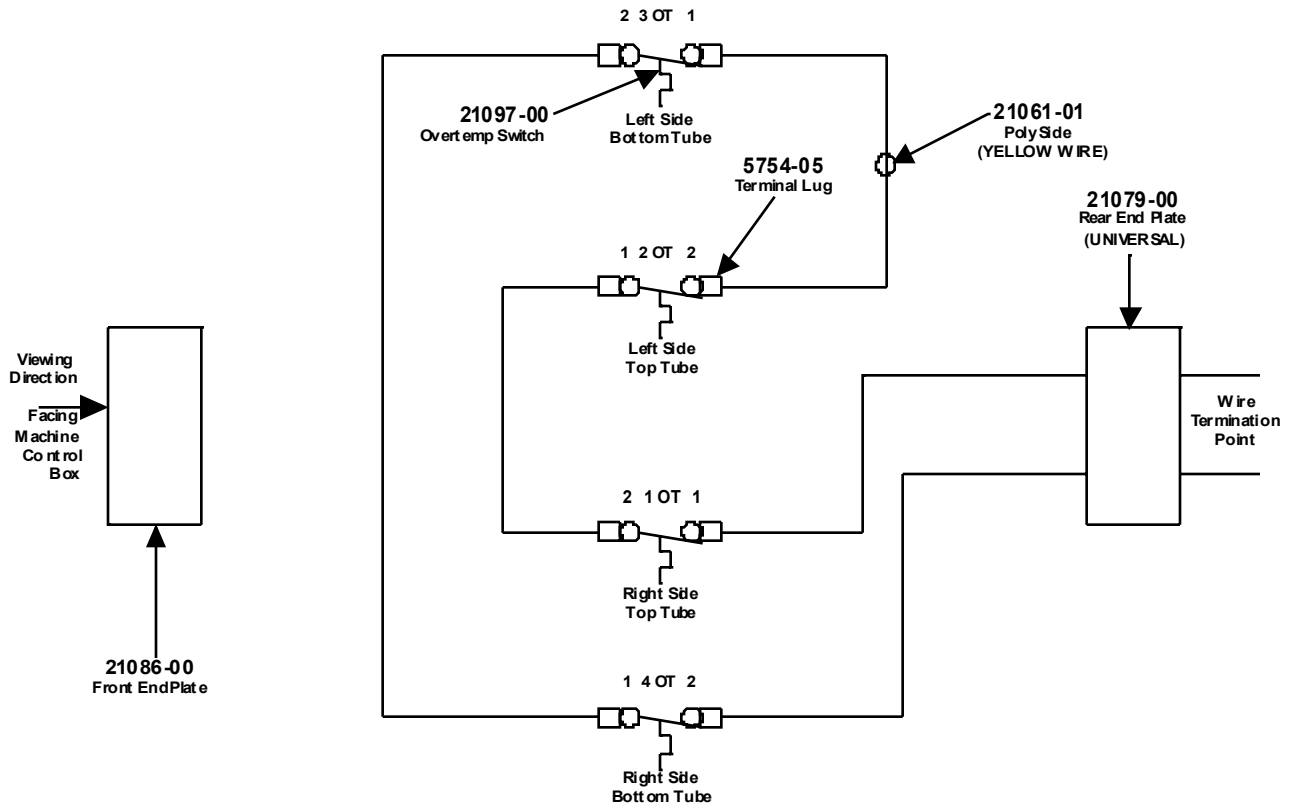

21404-35 HOSE ASSEMBLY

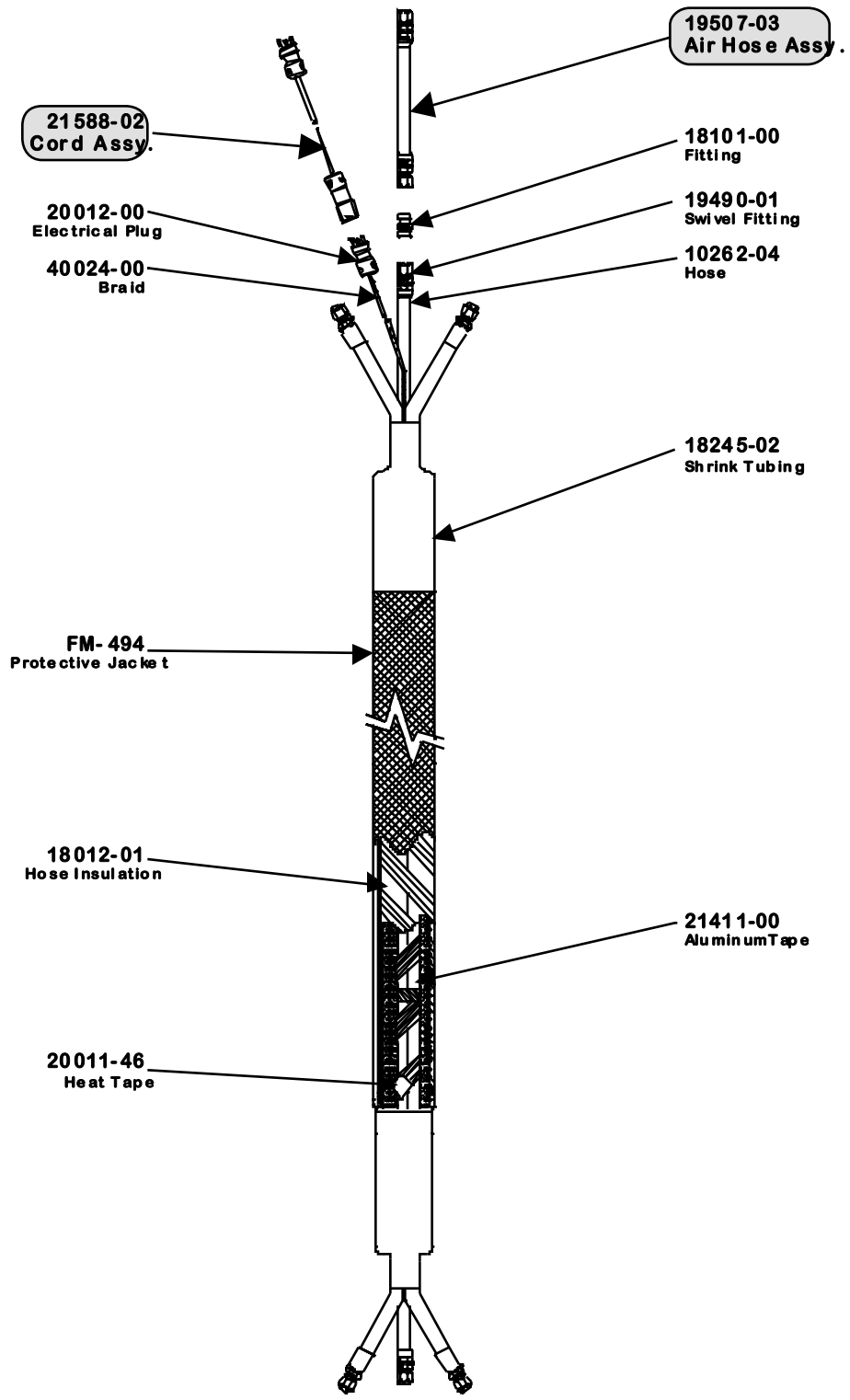

REVISED 8/9

17254-01 PROBLER SPRAY GUN

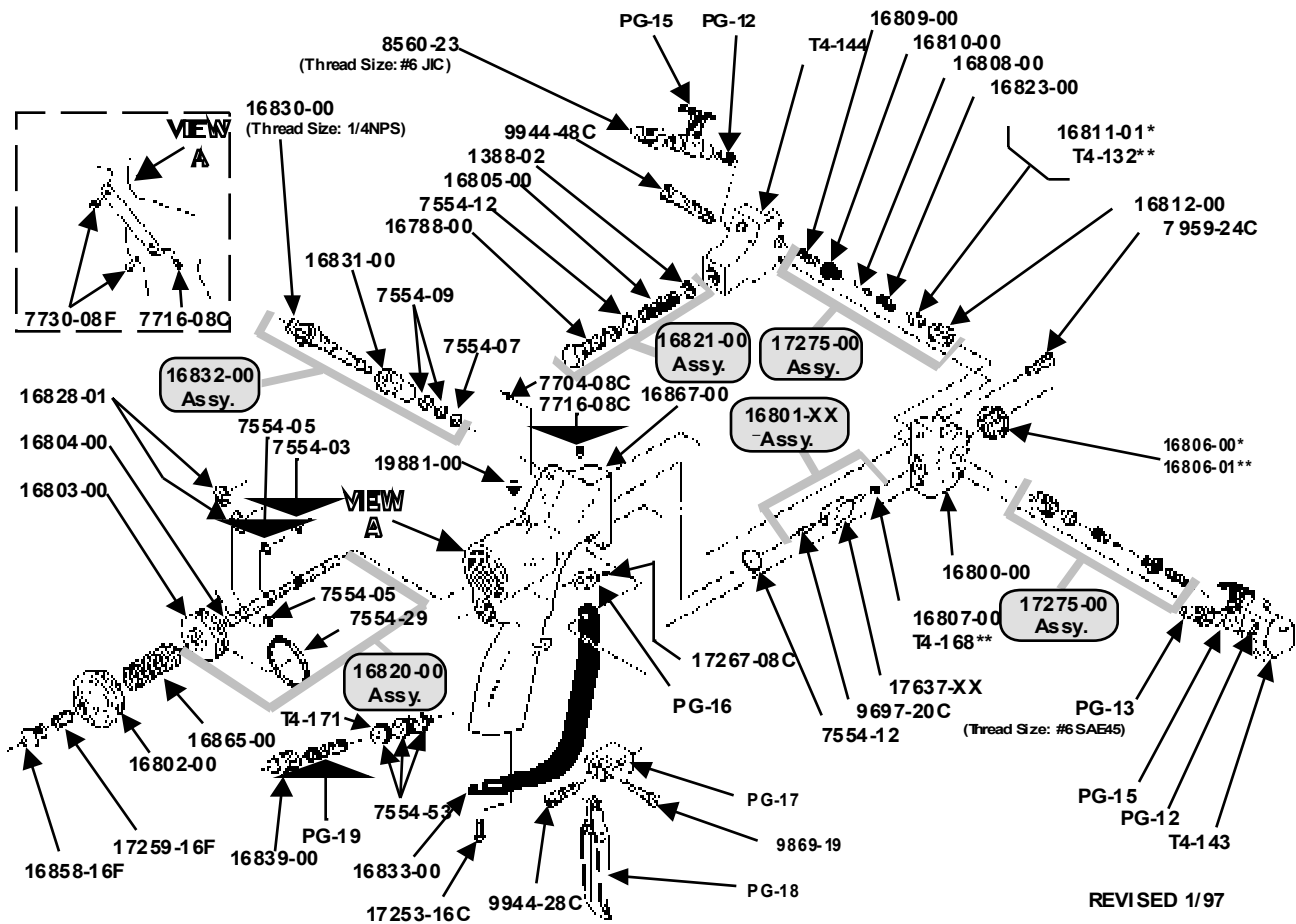

REVISED 1/97

* Used with 17254-00, -01, -02, -03 Gun Assembly

** Used with 17254-04, -05 Gun Assembly

REPAIR KIT: 19134-00

SAFETY

Safe Handling And Use of Urethane Foam Equipment

Introduction

Any tool, if used improperly, can be dangerous. Safety is ultimately the responsibility of those using the tool. In like manner, safe operation of polyester processes is the responsibility of those who use such processes and those who operate the equipment. This manual outlines procedures to be followed in conducting polyester operations safely.

All personnel involved in dispensing operations should read and understand this manual. It is most important that equipment operators, maintenance and supervisory personnel understand the requirements for safe operation.

This manual cannot answer every circumstance; each user should examine his own operation, develop his own safety program and be assured that his equipment operators follow correct procedures. Glas-Craft hopes that this manual is helpful to the user and recommends that the precautions in this manual be included in any such program.

Urethane foam systems are comprised of several different chemical compounds, some of which may be hazardous if improperly used.

CAUTION

Particular caution must be taken with respect to the vapors released during the use of urethane foam systems.

Isocyanate compounds are used in urethane foaming operations. The medical history of persons who may be exposed to such isocyanates should be examined. It is recommended that individuals with a history of chronic respiratory ailments should avoid exposure to all isocyanates.

In addition to the manual, Glas-Craft recommends that the user consult the regulations established under the Occupational Safety & Health Act (OSHA), particularly the following sections:

1910.94 Pertaining to ventilation.

1910.106 Pertaining to flammable liquids.

1910.107 Pertaining to spray finishing operations, particularly Paragraph (m) Organic Peroxides and Dual Component Coatings.

Local codes and authorities also have standards to be followed in the operation of your spraying equipment. Chemical manufacturer's recommendations should be obtained and considered. Your insurance carrier will be helpful in answering questions that arise in your development of safe procedures.

Personnel Safety Equipment

Glas-Craft recommends the following Personal Safety Equipment for conducting safe operations of the Polyester Systems:



EYE PROTECTION



HEARING PROTECTION



BREATHING PROTECTION

Glas-Craft recommends that the user consult the state and local regulations established for all Safety equipment listed.

Operating Safely

In operating urethane foam equipment safely, user should make every effort to:

1. Handle chemicals safely.
2. Provide adequate ventilation.
3. Provide adequate safety equipment (gloves, respirators, safety glasses, protective clothing, etc.) for operators and all others working in areas where they may be exposed to the chemicals or their vapors.
4. Avoid operating equipment which has given any indication of malfunction.
5. Become fully acquainted with the equipment and chemicals used.

Handling Chemicals Safely

Storage of polyisocyanates, diamines, and organic solvents should be isolated and restricted to specially constructed storage rooms. Store chemicals in original containers and according to manufacturer's recommendations listed on the container. Maximum ambient temperatures to which such chemicals should be exposed are specified by the manufacturer and **MUST NOT** be exceeded either in the storage area or in the spraying or pouring area.

To avoid moisture contamination, do not open containers until ready for use. After use, the remaining material should be re-sealed in the original container and stored in areas away from moisture.

During clean-up of spilled isocyanate-component, respirators, gloves and eye protection must be worn. Isocyanates which have been spilled can be controlled by covering them with dry saw dust and/or other absorbent inert materials. Care should be taken to avoid skin contact. The absorbent material and the absorbed isocyanate should be collected promptly, placed in an open-top container, and treated with dilute solutions of ammonium hydroxide and/or alcohol. While being treated in this manner, the material should be in an adequately ventilated area. Clothing on which any material has been spilled should be removed immediately, and cleaned before being worn again.

Clean-Up Solvents

WARNING

A hazardous situation may be present in your pressurized fluid system!

Halogenated Hydrocarbon Solvents can cause an explosion when used with aluminum or galvanized components in a closed (pressurized) fluid system (pumps, heaters, filters, valves, spray guns, tanks, etc.).

The explosion could cause serious injury, death and/or substantial property damage.

Cleaning agents, coatings, paints, etc. may contain Halogenated Hydrocarbon Solvents.

Some Glas-Craft spray equipment includes aluminum or galvanized components and will be affected by Halogenated Hydrocarbon Solvents.

A. There are three key elements to the Halogenated Hydrocarbon (HHC) solvent hazard.

1. **The presence of HHC solvents.** 1,1,1-Trichloroethane and Methylene Chloride are the most common of these solvents. However,

other HHC solvents are suspect if used; either as part of paint or adhesives formulation, or for clean-up or flushing.

2. **Aluminum or Galvanized Parts.** Most handling equipment contains these elements. In contact with these metals, HHC solvents could generate a corrosive reaction of a catalytic nature.

3. **Equipment capable of withstanding pressure.** When HHC solvents contact aluminum or galvanized parts inside a closed container, such as a pump, spray gun, or fluid handling system, the chemical reaction can, over time, result in a build-up of heat and pressure, which can reach explosive proportions.

When all three elements are present, the result can be an extremely violent explosion. The reaction can be sustained with very little aluminum or galvanized metal: **any amount of aluminum is too much.**

B. The reaction is unpredictable. Prior use of an HHC solvent without incident (corrosion or explosion) does **NOT** mean that such use is safe. These solvents can be dangerous alone (as a clean-up or flushing agent) or when used as a component of a coating material. There is no known inhibitor that is effective under all circumstances. Furthermore, the mixing of HHC solvents with other materials or solvents, such as MEK, alcohol, and toluene, may render the inhibitors ineffective.

C. The use of reclaimed solvents is particularly hazardous. Reclaimers may not add any inhibitors, or may add incorrect amounts of inhibitors, or may add improper types of inhibitors. Also, the possible presence of water in reclaimed solvents could feed the reaction.

D. Anodized or other oxide coatings cannot be relied upon to prevent the explosive reaction. Such coatings can be worn, cracked, scratched, or too thin to prevent contact. There is no known way to make oxide coatings or to employ aluminum alloys, which will safely prevent the chemical reaction under all circumstances.

E. Several solvent suppliers have recently begun promoting HHC solvents for use in coating systems. The increasing use of HHC solvents is increasing the risk. Because of their exemption from many State Implementation Plans as Volatile Organic Compounds (VOC's), their low flammability hazard, and their not being classified as toxic or carcinogenic substances, HHC solvents are very desirable in many respects.

WARNING

If you are now using Halogenated Hydrocarbon solvents in pressurized fluid systems having aluminum or galvanized wetted parts,

IMMEDIATELY TAKE THE FOLLOWING STEPS:

- > Empty system, shut-off, completely depressurize in accordance with equipment service instructions.
- > Remove equipment from service, disassemble in accordance with equipment servicing instructions.
- > Inspect all parts for corrosion and/or wear. Replace any damaged parts.
- > Thoroughly clean all parts of the equipment with a non-halogenated solvent and reassemble in accordance with equipment servicing instructions.
- > Flush equipment with non-halogenated solvent.
- > Do NOT reuse equipment with HHC solvents or with materials containing such solvents.
- > Material suppliers and/or container labels should be consulted to ensure that the solvents used are compatible with your equipment.

NOTE

Glas-Craft is aware of NO stabilizers available to prevent Halogenated Hydrocarbon solvents from reaction under all conditions with aluminum components in a closed fluid system.

TAKE IMMEDIATE ACTION...

Halogenated Hydrocarbon solvents are dangerous when used with aluminum components in a closed fluid system.

F. Consult your material supplier to determine whether your solvent or coating contains Halogenated Hydrocarbon Solvents.

G. Glas-Craft recommends that you contact your solvent supplier regarding the best non-flammable clean-up solvent with the heat toxicity for your application.

H. If, however, you find it necessary to use flammable solvents, they must be kept in approved, electrically grounded containers.

I. Bulk solvent should be stored in a well-ventilated, separate building, 50 feet away from your main plant.

J. You should allow only enough solvent for one day's use in your laminating area.

K. **"NO SMOKING"** signs must be posted and observed in all areas of storage or where solvents and other flammable materials are used.

L. Adequate ventilation (as covered in OSHA Section 1910.94 and NFPA No. 91) is important wherever solvents are stored or used, to minimize, confine and exhaust the solvent vapors.

M. Solvents should be handled in accordance with OSHA Section 1910.106 and 1910.107.

Toxicity of Chemicals

A. Glas-Craft recommends that you consult OSHA Sections 1910.94, 1910.106, 1910.107 and NFPA No. 33, Chapter 14, and NFPA No. 91.

B. Contact your chemical supplier(s) and determine the toxicity of the various chemicals used, as well as the best methods to prevent injury, irritation and danger to personnel.

C. Also determine the best methods of first aid treatment for each chemical used in your plant.

First Aid

If chemicals containing isocyanates are splashed on the skin, they can produce ill effects. Steps to counteract such effects should be started immediately.

1. Apply Tincture of Green Soap, full strength, to the contaminated area. If Tincture of Green Soap is not immediately available, wash the exposed area repeatedly with soap and water. Soap and water is not as desirable as using Tincture of Green Soap because many isocyanate components are not easily dissolved in water. In addition, soap and water does not form a barrier to the isocyanates.

2. After approximately two to four minutes, wash off the Tincture of Green Soap with water. If there is still an indication of isocyanate present, repeat the application. If the isocyanate contamination is on the facial area, care must be taken to avoid getting the Tincture of Green Soap in the eyes.

3. If the person develops breathing difficulties, oxygen should be administered. Quite often the exposed person will experience residual effects such as coughing spells. **CONTACT PHYSICIAN IMMEDIATELY.**

WARNING

Contact a doctor immediately in the event of an injury and give him the information you have collected. If your information includes first aid instructions, administer first aid immediately while you are contacting the doctor.

4. If a person accidentally swallows isocyanates, large amounts of water should be swallowed immediately. Vomiting should then be induced by patient sticking his finger down his throat, or by swallowing large quantities

of warm salt water or warm soapy water. After vomiting, more water should be taken to dilute isocyanate further. **CONTACT PHYSICIAN IMMEDIATELY.**

Ventilation

WARNING

Hazardous concentrations of some chemical vapors exist before they can be smelled. Chemical component suppliers should be contacted to determine at what concentrations the vapors of the chemicals they supply become dangerous, and the procedures and equipment needed to detect such dangerous concentrations. Such equipment should be obtained.

Adequate ventilation must be provided in any area where foam chemicals are sprayed or poured, and wherever the material containers are opened.

In industrial applications, foaming operations should be restricted to specific areas, and proper ventilation should be provided in these areas to prevent chemical vapors from spreading. Spray foaming operations MUST be restricted to a spray booth where a minimum exhaust of 100 feet per minute at the face of the booth is provided. Special care should be taken to prevent unsuspecting personnel both inside and outside of the plant from being exposed to chemical vapors. The chemical vapors should be exhausted to atmosphere in such a manner and at a sufficiently low concentration that personnel outside the plant are not exposed to dangerous concentrations of chemical vapors. Refer to OSHA Standards, sub-part G, 1910.107 and particularly sub-section (m) for Federal standards. State and local authorities may have applicable statutes or regulations concerning ventilation.

In contractor applications (for example, at a construction site, inside building or other enclosed space), the forced ventilation normally provided is likely to be inadequate. These applications, therefore, usually REQUIRE the use of forced, fresh air respirators for all persons in the areas where foaming operations are conducted or where the chemical vapors are likely to spread.

In industrial and contractor applications, it is advisable to run frequent tests to determine the exact concentration of isocyanate vapor in the air. Industrial equipment is available for making such determinations. Your chemical supplier can recommend such equipment and procedures.

Proper Safety Equipment

All persons spraying or working in areas where forced air ventilation is not adequate to remove isocyanate vapors from the air MUST use an approved (U.S. Bureau of Mines) fresh air supplied respirator.

Respirators should be regularly inspected, cleaned and disinfected according to good practices. Records must be kept of the inspections. The user MUST have a medical clearance indicating that he can safely use a respirator.

Respirators must fit securely, beards prevent a tight seal around the face. Eye glasses have to be given special attention and contact lenses are prohibited.

Safety goggles, gloves and other protective devices are suggested for operators of foaming equipment. Refer to OSHA Standards, sub-part 1, 1910.132, 1910.133 and 1910.134 for Federal standards.

IF YOU HAVE ANY QUESTIONS REGARDING THE ABOVE PRECAUTIONS OR ANY SERVICE OR OPERATION PROCEDURES, CALL YOUR **GLAS-CRAFT** DISTRIBUTOR OR **GLAS-CRAFT, INC.**

Notice

All statements, information and data given herein are believed to be accurate and reliable but are presented without guaranty, warranty or responsibility of any kind expressed or implied. The user should not assume that all safety measures are indicated or that other measures are not required.

GLAS-CRAFT, Inc.

**5845 WEST 82nd STREET, SUITE 102
INDIANAPOLIS, INDIANA 46278 U.S.A.**

PHONE (317) 875-5592

5456

FAX (317) 875-

APRIL 1996

INSTALLATION

Assembly Instructions

NOTE

The Glas-Craft MX System is factory assembled. If any questions arise concerning air or electrical connections, please refer to illustrations located in the forward portion of this User Manual or contact your Glas-Craft distributor.

A. Air Supply Connection

An air source which delivers a constant 45 CFM @ 100 PSI should be connected directly to the Fitting, P/N 8560-03, mounted on the Proportioning Unit Air Motor Regulator, P/N 22516-00. (see "22520-00 PROPORTIONING ASSEMBLY, Detail A" illustration)

The air line to the Console should be a minimum 1/2 inch inside diameter (I.D.) if it is 25 feet or less in length. Should it be over 25 feet in length, the air line should be a minimum 3/4 inch I.D.

B. Electrical Connections

1. Prior to connecting Main Power, insert Hose Electrical Plug, P/N 20012-00 into the Receptacle, P/N 21815-00 located on the front of the Hose Block (see "HOSE BLOCK ASSEMBLY" illustration)

WARNING

*Disconnect or turn **off** Main Power source before opening Control Panels Boxes to make any repairs or before making any electrical repair of any type to the MX system.*

CAUTION

*If you **do not** understand the electrical hook-up described above, consult your local **Glas-Craft** distributor OR a **qualified** electrician.*

OPERATION

Pre-Operation Checklist

- A. Check that **all** fittings are securely tight.
- B. Check electrical hook-up (*qualified* electrician recommended).
- C. Circuit Breaker on Control Box should be switched to **OFF** position.
- D. Main Air Regulator turned (counter clock-wise) to **OFF** position.

WARNING

Do not place any part of the body in the path of the material spray.

Do not point the gun at or near other personnel.

Do not look into the Mixing Chamber orifice at any time.

Because of the hazardous materials used in this equipment, it is recommended that the operator use an air mask, goggles, protective clothing, and other safety equipment as prescribed by current regulations, recommendations of the chemical suppliers, and the laws in the area where the equipment is being used.

A. Initial Start-Up Procedure

With all material and air lines connected and power cable attached, the system is now ready for start-up.

Filling The System

1. With all material and air lines connected and power cable attached to the system, the system is now ready to be filled with material. With transfer pumps in place, adjust regulators on transfer pumps to 30-50 psi to fill the system. Transfer pumps will cycle to fill pumps, heaters and hoses and then stop.
2. Remove the Side Blocks, P/Ns T4-143 and T4-144, on the front housing of the Gun, by removing Screws, P/N 9944-48C.

3. Place separate clean containers under each individual Side Block. Open manual Material Valves (black arrow forward, see Fig. 2 & 3) on each Side Block to allow trapped air to escape the Hose and material to flow into the containers until all air is purged from the material system. (see Fig. 1)



Fig. 1

NOTE

Remember to dispense one to two gallons of material to clear the system of grease and plasticizer that was used during factory testing.

4. Close manual Material Valves. Material pressures gauges should now register approximately equal pressure. If one side registers considerably more pressure than the other side, go to the high pressure side and bleed off some pressure by slightly opening the manual Material Valve on the Side Block over the container. Bleed pressure until both sides are approximately the same pressure.
5. Dispose of waste material properly and in accordance with chemical suppliers instructions and local, state and federal regulations.



NOTE

Before re-assembling Side Blocks, lubrication can be applied by dabbing a white lithium grease into holes inside of Gun Front Housing and wiping grease over Side Block Seals. Grease will purge itself when air valve is turned on at Gun and Gun is triggered.

6. Clean and lubricate Side Blocks and Seals thoroughly and re-assemble on Gun. Make certain that Side Block Screws are tighten securely.
7. Refer to Glas-Craft Material Operating Instructions for proper preparation of material, i.e, mixers, etc.
8. Make sure Main Proportioning Unit regulator, P/N 22516-00, is dialed (counter clock-wise) to zero.
9. Slowly adjust Regulator, P/N 18199-02, on the MX system to control Transfer Pumps. Regulator should be dialed up to 90-100 psi.

NOTE

Turn Transfer Pump Air Regulator on slowly. Pumps should cycle slowly until hoses are full of material.

10. Turn on Main Power.
11. Turn on Hose Control. This is done by pushing in the green button. Adjust temperature to desired setting by depressing the blue "SET" button and press either  or  button on the Controller simultaneously until desired temperature setting is achieved.

NOTE

Allow proper time for hose to warm up (approximately 15-20 minutes).

NOTE

To adjust temperature on Hose Controller, push and hold in blue button. Then push the up or down arrow to increase or decrease temperature. To see actual temperature of liquid in hose, push blue button once and release. The actual temperature will then be displayed for 10 seconds.

12. Turn on the ISO and POLY Heaters by pushing in the green buttons.
13. Adjust temperature to desired setting. ISO and POLY Controllers function exactly the same as the Hose Controller.

NOTE

Allow proper time for material to be heated (approximately 3-5 minutes).

14. Turn Purge Air and Material Valves ON at Gun. (see Fig. 2 & 3)

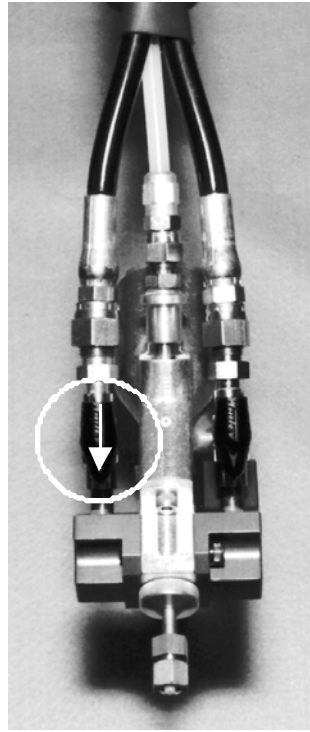

Fig. 2

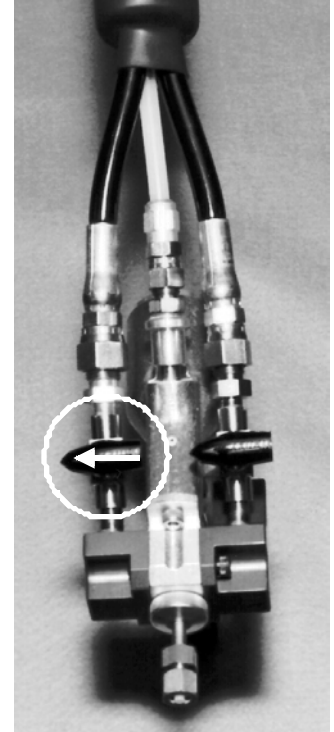

Fig. 3

15. Relieve any excess pressure by triggering the gun.
16. Dial-up Main Proportioning Unit regulator, P/N 21825-611, to desired pressure.

NOTE

Standard operating pressure should be set at 100 psi.

17. The system is now ready for operation.

B. Over Pressure System Protection

The MX system incorporates monitors for high pressure monitoring. These monitoring devices will

prevent the MX system from continued operation if high pressure situations develop.

There are two pressure sensors located on each proportioning pump. The high pressure sensor is located at the outbound of the fluid section.

The high pressure monitoring sensor will engage if fluid pressure increases above 3200 psi.

If a high pressure situation develops, the sensor will detect this and immediately engage the hold-in circuit.

This will disengage power to the air motor and it will stop cycling. It will also turn the heater off.

On the control box panel, there are two yellow lighted push buttons marked over pressure. One of these push buttons will be illuminated after the monitoring sensor engages, indicating where the problem is located (ISO or Poly).

In the over pressure situation, the system will remain shutdown until it is manually reset.

At this point, it is necessary to determine if the problem is an over pressure situation.

When the sensor engages, the system will be frozen, giving you the pressure readings at the time the problem was detected.

Inspect the fluid pressure gauges, in an over pressure situation, one of the fluid pressure gauges will be significantly higher than the other gauge.

WARNING

When main power to unit is on, the console will have wires that are live. Disconnect or turn off main power source before opening console to make any repairs.

WARNING

Before performing any repairs on the system, ALL AIR and FLUID PRESSURES SHOULD BE RELIEVED TO ZERO (BLEED-OFF)!

C. Over Pressure Problem Correction

1. Determine if the problem is high pressure related.
2. Relieve system hydraulic pressure.
3. Turn off main power
4. Fix the problem area:
 - a. Potential high pressure causes:
 - Restriction
 - Overheating material in static position
 - ISO filter at gun
5. Re-start system for operation
6. Once the power has been turned off and problem solved, and the main power is turned on again, the over/under pressure lighted buttons will automatically be reset.

D. Control Panels

MX System Control Panel Specifications

- **208 VAC**
- **60 Amp**
- **Single Phase**
- **50/60 Cycles**

Main power cord has three wires:

- **Black - L1 (Power)**
- **White - L2 (Power)**
- **Green - Ground**

CAUTION

*If you **do not** understand the electrical hook-up described above, consult your local **Glas-Craft** distributor OR a **qualified** electrician.*

It is recommended that a qualified, licensed electrician should install power to the supply disconnect.

You should always follow all local or national electrical codes.

CAUTION

Disconnect power source BEFORE attempting any repairs or opening the Control Boxes. Access to internal parts is limited to qualified personnel ONLY!

Place Main Power Breaker in OFF position BEFORE disconnecting power cables. This equipment is not approved for use in hazardous locations as set forth in the National Electrical Code Article 500 and Sub-Part "S" of the OSHA Standards.

The green, small bulb lights on the Control Panel are cycle lights. They will illuminate when that component is actively cycling.

E. Proportioning Pump

Air Motor

- 6 inch diameter air motor with a 4 inch stroke.

NOTE

Supply air to air motor should be clean, dry air.

A Gauge/Regulator/Water Trap is located on the in-bound Main Air port of the Air Motor. The Water Trap should be drained after each use.

Fluid Sections

The wiper/lubrication cup at the top of each fluid section is designed to keep piston shaft clean and lubricate throat seal.

This special design requires very little maintenance.

Each month:

1. Wipe any residue from the mouth of the lubrication cup.
2. Add 1 teaspoon of a suitable lubricating solution.

Hoses

Each MX system is supplied with a 35 ft. high Heated Hose assembly.

A temperature sensing thermocouple is run 13 ft. into the B-side of the Hose assembly. This is where actual (process) material temperature is measured and reflected at the Hose Controller.

If additional hose lengths are required:

- 21404-35 Lead Hose
- 21403-35 Extension Hose

The P/N 21404-35 Lead Hose is supplied with the MX system. If additional hose assemblies are required, order P/N 21403-35 Extension Hose.

The P/N 21404-35 Lead Hose must be attached to the Gun. Extension Hoses (P/N 21403-35) are added to the Lead Hose and then attached to the machine.

NOTE

The MX system, with 35' hose assembly, has a 1 amp hose fuse in the lower control box. If extra length hoses are required, the hose fuses **must** also be changed as follows...

<u>Hose Length</u>	<u>Current Rating</u>
35'	1.55 amp
70'	3.10 amp
105'	4.64 amp
140'	6.19 amp
175'	7.74 amp
210'	9.29 amp

Stroke Counter

OPTIONAL: contact Glas-Craft Technical Service Department.

- Per stroke the total volume output will be:
.021 x strokes = U.S. gallons.
(with 1:1 pumps)

F. System Shut-Down

1. Turn Main Circuit Breaker to OFF position.
2. Perform Gun maintenance as follows:
 - a. Check for leaking Seals, P/N 16811-00:
 - Turn OFF Gun incoming air by closing Gun Air Switch.
 - Wait approximately 10-20 seconds, then turn ON incoming air by opening Gun Air Switch.
 - Repeat two or three times.

- If any material has been purged from the Gun, the Seals, P/N 16811-00 are leaking.
- Correct leaks by replacing seals and re-checking.
- b. Check for leaking Material Valve, P/N PG-15:
 - Turn OFF both Material Valves.
 - Trigger Gun several times.
 - Turn OFF Gun incoming air by closing Gun Air Switch.
 - Trigger Gun several times.
 - If additional material is purged, the Material Valves are leaking.
 - Correct leaks by taking off Black Knobs and turning packing 1/8 to 1/4 turns at a time until leak has stopped. Re-check.
- c. Check Side Blocks:
 - Turn OFF the Air Switch on Gun.

build-up. Carefully, without scratching the seal surfaces (sides), remove any accumulated material. Solvent can be used to wash accumulated material off of Chamber, Side Blocks, etc. Keep Gun Chamber tilted toward the ground so that solvent does not run back into Gun. Certain solvents will attack O-Rings on Chamber Shaft causing swelling and deterioration of O-Rings.

- Place generous amounts of high quality, white lithium grease in each side of the Gun Front Housing and on the Side Block Seals.
- Use a No. 50 Drill Bit to clean out the Mixing Chamber exit passage. Use a No. 55 Drill Bit to clean the inlet side holes of the Mixing Chamber taking care not to scratch the Mixing Chamber's polished surfaces.
- Re-assemble the Side Blocks and tighten Screws securely. Grease should appear at the tip of the Mixing Chamber. DO NOT open Air Switch on Gun because this will purge grease from the Gun. The grease should be allowed to remain in the Gun overnight.

3. Reduce Main Air Regulator setting to ZERO.
4. Visually inspect entire system for leaks.
5. Turn OFF Main Air Supply.

WARNING

Before removing Side Blocks make certain that both Gun Material Valves are in the fully OFF positions!

Refer to Figures 4 and 5.

If Material Valves are on when Side Blocks are removed, the Gun will quickly become encased in urethane!

WARNING

Point Gun Side Blocks down, away from all personnel. Existing fluid pressures could cause material to exit the Side Blocks with considerable force.

- Take off Side Blocks by removing Screws, P/N 9944-48C.
- Examine the sides of the Mixing Chamber, P/N 17637-XX for scratches and/or material

CAUTION

Do not bleed fluid pressure from the system.

OVERHAUL PROCEDURE

19875-00 (-01) Pumps 21835-00 Pumps

1. Dump pressure off system

WARNING

Be sure air and power are off to system.

This is achieved by splitting side blocks of of gun, opening ball valves and purging materials into clean containers.

2. Flush system side to be rebuilt with suitable solvent.

NOTE

This is optional, it makes the process easier.

3. Disconnect inlet fitting from the bottom of the pump.
4. Disconnect outlet fitting from the top of the pump.
 - a. Systems with Over Pressure Valve: remove DIN connector from switch, Phillips screw.
 - b. Remove Over Pressure Switch from fitting.

CAUTION

Do not immerse Over Pressure Valve in solvents externally. (Flushing will not affect).

5. Remove pump from base.
 1. Loosen and remove P/N 7729-10 Nylon Lock Nut from yoke.

(Older MX Systems), loosen allen screw screw in yoke, remove Hitch Pin, pull out Clevis Pin.

- b. Loosen and remove four bolts, P/N 9945-48C.

Breaking Down Pump

1. Loosen four nuts, P/N 7733-17 at the base of pump and remove, break loose, in a criss-cross pattern.
2. Remove Base, P/N P33-11 from Tie Rods, P/N 18289-00.

NOTE

On P/N 21835-00 pumps, watch out for APS-119, APS-128, & 19633-00. The 19633-00 will push these parts out. Observe which side of the APS-119 comes out, Keep right side up for diagnostics.

3. Remove Valve Housing from the cylinder.
P/N UF-118 on 19875-00 pump.
P/N, 19634-00 on 21835-00 pump.
4. Using a rubber mallet, tap shaft out through the bottom of the cylinder, P/N 18219-00.
5. Remove cylinder, P/N 18219-00 from Pump Head, P/N 18227-00.
6. Remove Cup Adapter, P/N 21440-00 from Pump Head, P/N 18227-00.

Disassemble Sub-Assemblies

1. Cup Adapter, P/N 21440-00.
 - a. Remove Support Washer, P/N 18295-01.
 - b. Remove Seal, P/N 21595-00.
 - c. Remove Snap Ring, P/N 1005-02, Nylon Washer, P/N 21896-01, & Felt Wipers, P/N 21897-01.
2. Shaft Assembly:
 - a) Remove P/N 21598-00, Transfer Seat from P/N 21597-00, Transfer Housing. Watch for P/N APS-133, Ball and P/N 21803-00, Spring. The Ball is loaded with spring tension.

- b. Remove FS-110, Piston Guide and P/N 21595-00 Pump Seal.

Cleaning

1. Thoroughly wash all parts in suitable solvent.
2. If parts have any build-up of hardened material, it is acceptable to polish parts with fine sand paper,(1200 grit) or steel wool(000).
3. It is recommended that the cylinder be honed with a fine grit bead honer,(P/N RK5-2).

Inspection

1. The Pump Cylinder, P/N 18219-00 inner wall should be smooth. No pitting or scarring should be seen. If slight scars show in the wall, they must not be able to be felt with a finger nail.
2. The Pump Shaft, P/N 21599-00 must not have any scoring, pitting, or build up of any debris on the shaft.
3. Set the Ball, P/N APS-133 in the Seat, P/N 21598-00 and hold up to a light. Observe for light between seat surface and the ball.

NOTE

If a large sliver of light shows, check for debris or scarring on Seat or Ball.

4. P/N APS-128 & P/N APS-119 repeat the above step.

NOTE

The APS-119 is reversible, you can use either side.

Re- Assemble

NOTE

All parts underlined are contained in repair kit.

2. Soak P/N 21897-01 in a light weight, non detergent oil, then install in P/N 21440-00.
3. Install P/N 21896-01, push down and install Snap Ring P/N 1005-02 in groove.
4. On bottom side of P/N 21440-00 install P/N 21595-00 in housings so that the lip faces out.
5. Lubricate and install O-Ring, P/N 13867-43 on bottom groove.
6. Install P/N 18295-01 with lip facing toward P/N 21595-00 seal.
7. Place P/N 21595-00 Seal and P/N FS-110 guide on P/N 21597-00. The lips of the Seal will face away from P/N FS-110.
8. Set P/N 21803-00 Spring in P/N 21597-00 Housing and set APS-133 Ball on Spring.
9. Apply blue lock-tite to the threads of P/N 21598-00 and install on P/N 21597-00. Tighten these two parts!
10. Lubricate and install two P/N 13867-49 O- Rings on P/N 18219-00 cylinder.
11. Using a light weight non-detergent oil, coat the seal on the shaft assembly and the walls of the cylinder, then install the shaft assembly into the cylinder, leave approximately 4" of the shaft exposed on the top side.
12. Install cylinder/shaft assembly into P/N 18227-00 Pump Head, careful not to cut O-Ring for Pump P/N 21835-00.
13. With the Pump Assembly upside down, (easy if clamped in a vise) install Foot Valve Housing P/N 19634-00.
14. Set P/N 19633-00 Spring in place and set P/N APS-128 Ball on Spring.
15. Lubricate and install P/N 13867-44 O-Ring in groove of P/N 19634-00.
16. Lubricate the outer edge of P/N APS-119 and set top of ball, square and center flats of P/N APS-119 and P/N 19634-00.

17. Gently set P/N P33-11 through P/N 18289-00 Tie Rods and push down square and firm until it sets down over cylinder O-Ring.
18. Continue holding P33-11 down, install (4) P/N 7734-12 Lock Washers and hand thread (4) P/N 7733-17 Nuts.
19. Tighten P/N 7733-17 in a criss- cross pattern until tight.
4. Install P/N APS-119.
5. Gently set P/N P33-11 through P/N 18289-00 Tie Rods and push down square and firm until it sets down over cylinder O-Ring.
6. Continue holding P33-11 down, install 4 P/N 7734-12 Lock Washers and hand thread 4 P/N 7733-17 Nuts.
7. Tighten P/N 7733-17 in a criss- cross pattern until tight.

For 19875-00 Pumps:

1. Set UF-118 in cylinder.
2. Set P/N APS-128 in body.
3. Lubricate P/N 13867-44 and install in groove of UF-118.
8. Lubricate P/N 21595-00 Seal (inside of P/N 21440-00 housing).
9. Gently push down over Pump Shaft P/N 21599-00 and set flush to P/N 18227-00 Pump Head.
10. Re-install pump in reverse order of removal.

LIMITED WARRANTY POLICY

GLAS-CRAFT, INC. ("Glas-Craft") warrants to the original Purchaser of Glas-Craft manufactured equipment and parts, that all Glas-Craft manufactured equipment and parts will conform to their published written specifications and be free of defects in workmanship and material for a period of one (1) year from the original date of installation. Glas-Craft makes no warranty to any one other than the original Purchaser.

If any Glas-Craft manufactured part or equipment is found to be defective in workmanship or material within the one-year period from the date of installation, as determined solely by Glas-Craft, Glas-Craft, in its sole discretion, will either repair or replace the defective part or equipment at Glas-Craft's cost, including freight charges both ways, or credit or refund the purchase price for the defective equipment or part.

A warranty claim will be honored only when:

1. Glas-Craft has been informed, in writing, of any such defect in workmanship or material within ten (10) days after discovery by the original Purchaser;
2. An official of Glas-Craft has issued a return authorization number; and
3. The claimed defective equipment or part has been returned to Glas-Craft by the original Purchaser, freight prepaid (with proper return authorization number(s) attached), to: Glas-Craft, Inc., 5845 West 82nd Street, Suite 102, Indianapolis, IN 46278, U.S.A.

This warranty shall not apply to any equipment or parts that have been altered or repaired by anyone other than Glas-Craft or to defects or damage resulting from improper installation, misuse, negligence, accident, or use not specified by Glas-Craft. This warranty shall not apply to any equipment where any parts or components were replaced by any parts or components not manufactured or supplied by Glas-Craft. The decision by Glas-Craft shall be conclusive and binding on Purchaser.

Glas-Craft does not warrant that any equipment or parts sold to Purchaser meet or comply with any local, state, federal, or other jurisdiction's regulations or codes. Glas-Craft does not warrant that any equipment or part sold to Purchaser, when used individually or in concert with any other part, equipment, device, component or process, does not infringe on any patent rights of any third party. Glas-Craft only warrants that it has no specific knowledge of any such infringement.

Glas-Craft makes no warranty as to any parts or equipment manufactured by others. Purchaser shall look solely and only to the manufacturer of such parts or equipment with respect to any warranty claims. Glas-Craft hereby assigns to Purchaser the original manufacturer's warranties to all such equipment and parts, to the full extent permitted.

THE AFORESAID WARRANTY IS IN LIEU OF ALL OTHER WARRANTIES, EXPRESS OR IMPLIED. SPECIFICALLY THERE ARE NO WARRANTIES OF MERCHANTABILITY OR FITNESS FOR A PARTICULAR PURPOSE, WHICH WARRANTIES ARE SPECIFICALLY DISCLAIMED.

Glas-Craft shall not be liable for any loss or expense resulting from damage or accidents caused by improper use or application of materials manufactured or sold by Glas-Craft or its distributors or agents.

UNDER NO CIRCUMSTANCES SHALL GLAS-CRAFT'S LIABILITY EXCEED THE AMOUNT PURCHASER PAID FOR THE CLAIMED DEFECTIVE EQUIPMENT OR PART. UNDER NO CIRCUMSTANCES SHALL GLAS-CRAFT BE LIABLE FOR INCIDENTAL OR CONSEQUENTIAL DAMAGES OR FOR LOST PROFITS.

No action arising from or relating to any goods manufactured by or purchased from Glas-Craft may be brought more than one (1) year after the cause of action accrues.

IF YOU HAVE AN EQUIPMENT PROBLEM...

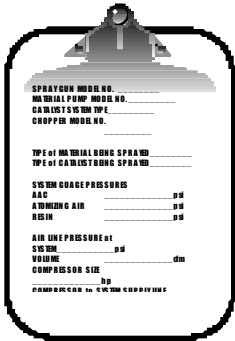

If you have a problem that requires Distributor or Glas-Craft Service Department help, gather the following information ***BEFORE*** you pick-up the telephone.



	Model No.	Serial No.
SPRAY GUN SYSTEM		
TYPE of MATERIAL BEING SPRAYED		
SYSTEM GUAGE PRESSURES		
ISO HEATER GUAGE		PSI
POLY HEATER GUAGE		PSI
MATERIAL PUMP AIR MOTOR		PSI
MAIN AIR LINE PRESSURE at SYSTEM		PSI
MAIN AIR LINE VOLUME		CFM
COMPRESSOR SIZE		HP
COMPRESSOR to SYSTEM SUPPLY LINE SIZE		INCHES

*Have a general equipment or operation question?
You can contact the Glas-Craft Service Department via E-Mail at
gciservice@glascraft.com*

FOR YOUR REFERENCE

DATE PURCHASED _____
DISTRIBUTOR _____

CONTACT _____
PHONE _____

Manufacturers of ...

*Fixed and Variable Ratio Systems and Equipment for Polyurethane, Polyurea
and Hybrid Materials Spray, Pour and Injection*

Micro II, Maxi II, Super Maxi, Mini III, MX, MX II, MH, MH II & MH III

SYSTEMS and EQUIPMENT for...

- *SPRAY, POUR & INJECT*
- *FIXED & VARIABLE RATIO SYSTEMS*
- *EQUIPMENT FOR POLYURETHANE FOAMS, COATINGS and
POLYUREAS*

...featuring the patented Probler Spray/Pour Gun

LPA Series

*"Low Pressure, AIR ASSIST CONTAINMENT, Airless
External-Mix"*

Gel-Coat, Wet-Out, & Chopper
Systems and Equipment

INDy Series

"Internal-Mix Non-Atomized Dispense Systems"

Gel-Coat, Wet-Out,
Chopper & Pressure Fed Roller
Systems and Equipment

**For more information concerning any of these Glas-Craft products,
contact your local authorized Glas-Craft distributor, or**

Glas-Craft, Inc.

5845 WEST 82nd STREET, SUITE 102
PHONE (317) 875-5592
E-Mail sales@glascraft.com

INDIANAPOLIS, INDIANA 46278 U.S.A.
FAX (317) 875-5456
Web Site www.glascraft.com

INSPECTION REPORT

FOAM EQUIPMENT					
<input type="checkbox"/> Micro II	<input type="checkbox"/> Mini III	<input type="checkbox"/> MH			
<input type="checkbox"/> Maxi II	<input type="checkbox"/> MX	<input type="checkbox"/> MH II			
<input type="checkbox"/> Maxi III	<input type="checkbox"/> MX II	<input type="checkbox"/> MH III			
<input type="checkbox"/> Super Maxi	<input type="checkbox"/>	<input type="checkbox"/>			
PART NO. _____		INSPECTED BY _____			
SERIAL NO. _____		INSPECTION DATE _____			
NEW <input type="checkbox"/>		REPAIR <input type="checkbox"/>		RETURN <input type="checkbox"/>	
VISUAL INSPECTION					
	ACCEPT	REJECT		ACCEPT	REJECT
APPEARANCE	□	□	FLUID FILTERS	□	□
VALVE SEQUENCE	□	□	POWER CORD	□	□
FUNCTIONAL TESTS					
	ACCEPT	REJECT			
SMOOTHNESS of PUMP OPERATION	□	□			
PUMP OUTPUT PRESSURE	□	□			
PUMP DEAD-HEAD PRESSURE	□	□			
ELECTRICAL WIRING & CONNECTIONS	□	□			
ELECTRICAL CONTROL FUNCTIONS	□	□			
HEATER OPERATION	□	□			
AIR CONNECTIONS	□	□			
OVER PRESSURE SENSORS	□	□			
<input type="checkbox"/> SERVICE MANUAL		<input type="checkbox"/> LITERATURE			
REMARKS					



www.glascraft.com

GC-1230

5845 WEST 82nd STREET
INDIANAPOLIS, INDIANA 46278 U.S.A.

Phone (317) 875-5592
Fax (317) 875-5456
E-Mail sales@glascraft.com

REVISED OCTOBER 2000