

GX-7A, GX-7 DI, and GX-7 400 Spray Guns

311321F

*For use with non-flammable polyurethane foams, two-component coating systems (polyureas), and some two-component epoxy systems.
Not for use in explosive atmospheres.*

See page 2 for model information.

3500 psi (24 MPa, 240 bar) Maximum Working Pressure



Important Safety Instructions

Read all warnings and instructions in this manual. Save these instructions.

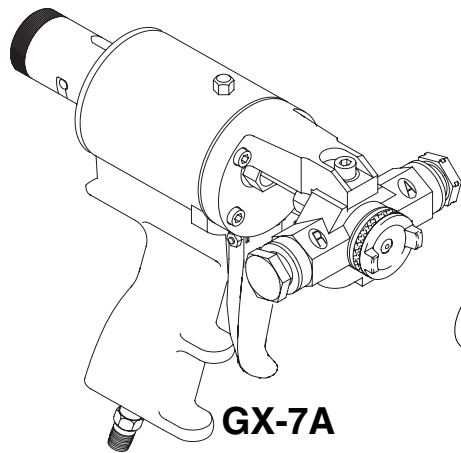

GX-7A

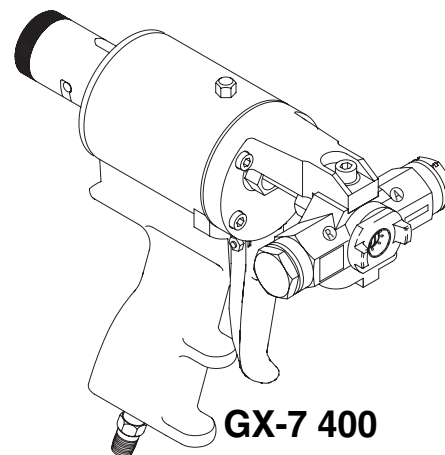

GX-7 400

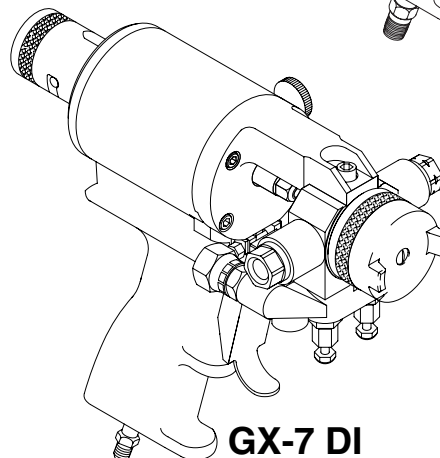

GX-7 DI

GRACO | GUSMER

Contents





| | | | |
|--|-----------|--|-----------|
| Models | 2 | Repair | 22 |
| Warnings | 3 | Service Screen Screw | 22 |
| Overall View | 6 | Remove Centerline Components | 22 |
| Centerline Components | 8 | Install Centerline Components | 24 |
| Mixing Module | 10 | Replace End Cap and Air Piston Assembly ... | 25 |
| Operation Basics | 11 | Replace Trigger Valve O-Rings | 26 |
| Isocyanate Hazard | 11 | Clean Mixing Module | 27 |
| Keep A and B Components Separate | 11 | Install Mixing Module | 28 |
| Grounding | 11 | Clean Pattern Control Disc | 29 |
| Safety Position | 11 | Parts | 30 |
| Air Hose Connection | 12 | GX-7A Model Final Assembly | 30 |
| Coupling Block | 13 | GX-7 DI Model Final Assembly (295541) | 32 |
| Air Inlet Configuration | 14 | GX-7 400 Model Final Assembly (295540) | 34 |
| Mixing Module and PCD Installation | 15 | GX-7A Model Handle Assembly (295810) | 36 |
| Valving Rod Adjustment | 16 | GX-7 DI Model Handle Assembly (295809) ... | 38 |
| Valving Rod Adjustment | 16 | GX-7 400 Model Handle Assembly (295799) .. | 40 |
| Initial Set Up | 17 | Coupling Block Assembly (295383) | 42 |
| Daily Start-up | 18 | Specifications | 43 |
| Daily Shutdown | 18 | GX-7A Mix Module Kit | 43 |
| Pressure Relief Procedure | 19 | Set-Up Chart for GX-7A Model | 44 |
| Maintenance | 20 | GX-7 400 Mix Module Kit | 45 |
| Gun Service Kits | 20 | Set-up Chart for GX-7 400 Model | 46 |
| Clean Spray Gun Procedure | 20 | GX-7 DI Model Specifications | 47 |
| Flush Gun | 21 | Tip Kits | 48 |
| | | Tool Kits | 48 |
| | | Technical Data | 49 |
| | | Graco Standard Warranty | 50 |
| | | Graco Information | 50 |

Models

| Part No. | Description | Includes: | |
|----------|-----------------|--------------|--------------|
| | | Mix Module | Tip |
| 295540 | GX-7 400 | 296859 (451) | 296853 (212) |
| 295541 | GX-7 DI - 4/213 | 296901 (4) | 296706 (213) |
| 295542 | GX-7A - 1/90 | 296909 (1) | 296712 (90) |
| 295543 | GX-7A - 10/210 | 296906 (10) | 296704 (210) |
| 295544 | GX-7A - 3/70 | 296226 (3) | 296710 (70) |
| 295545 | GX-7A - 5/70 | 296923 (5) | 296710 (70) |

Warnings

The following general warnings are for the setup, use, grounding, maintenance, and repair of this equipment. Additional, more specific warnings may be found throughout the body of this manual where applicable. *Symbols appearing in the body of the manual refer to these general warnings. When these symbols appear throughout the manual, refer back to these pages for a description of the specific hazard.*

|  WARNING | |
|--|---|
|  | <p>PERSONAL PROTECTIVE EQUIPMENT</p> <p>You must wear appropriate protective equipment when operating, servicing, or when in the operating area of the equipment to help protect you from serious injury, including eye injury, inhalation of toxic fumes, burns, and hearing loss. This equipment includes but is not limited to:</p> <ul style="list-style-type: none"> • Protective eyewear • Clothing and respirator as recommended by the fluid and solvent manufacturer • Gloves • Hearing protection |
|  | <p>TOXIC FLUID OR FUMES HAZARD</p> <p>Toxic fluids or fumes can cause serious injury or death if splashed in the eyes or on skin, inhaled, or swallowed.</p> <ul style="list-style-type: none"> • Read MSDS's to know the specific hazards of the fluids you are using. • Store hazardous fluid in approved containers, and dispose of it according to applicable guidelines. |
|   | <p>SKIN INJECTION HAZARD</p> <p>High-pressure fluid from gun, hose leaks, or ruptured components will pierce skin. This may look like just a cut, but it is a serious injury that can result in amputation. Get immediate surgical treatment.</p> <ul style="list-style-type: none"> • Do not point gun at anyone or at any part of the body. • Do not put your hand over the spray tip. • Do not stop or deflect leaks with your hand, body, glove, or rag. • Do not spray without tip guard and trigger guard installed. • Engage trigger lock when not spraying. • Follow Pressure Relief Procedure in this manual, when you stop spraying and before cleaning, checking, or servicing equipment. |

WARNING
**FIRE AND EXPLOSION HAZARD**

Flammable fumes, such as solvent and paint fumes, in **work area** can ignite or explode. To help prevent fire and explosion:

- Use equipment only in well ventilated area.
- Eliminate all ignition sources; such as pilot lights, cigarettes, portable electric lamps, and plastic drop cloths (potential static arc).
- Keep work area free of debris, including solvent, rags and gasoline.
- Do not plug or unplug power cords, or turn power or light switches on or off when flammable fumes are present.
- Ground all equipment in the work area. See **Grounding** instructions.
- Use only grounded hoses.
- Hold gun firmly to side of grounded pail when triggering into pail.
- If there is static sparking or you feel a shock, **stop operation immediately**. Do not use equipment until you identify and correct the problem.
- Keep a fire extinguisher in the work area.

**EQUIPMENT MISUSE HAZARD**

Misuse can cause death or serious injury.

- Do not operate the unit when fatigued or under the influence of drugs or alcohol.
- Do not exceed the maximum working pressure or temperature rating of the lowest rated system component. See **Technical Data** in all equipment manuals.
- Use fluids and solvents that are compatible with equipment wetted parts. See **Technical Data** in all equipment manuals. Read fluid and solvent manufacturer's warnings. For complete information about your material, request MSDS forms from distributor or retailer.
- Check equipment daily. Repair or replace worn or damaged parts immediately with genuine Graco/Gusmer replacement parts only.
- Do not alter or modify equipment.
- Use equipment only for its intended purpose. Call your Graco/Gusmer distributor for information.
- Route hoses and cables away from traffic areas, sharp edges, moving parts, and hot surfaces.
- Do not kink or over bend hoses or use hoses to pull equipment.
- Keep children and animals away from work area.
- Comply with all applicable safety regulations.

**PRESSURIZED EQUIPMENT HAZARD**

Fluid from the gun/dispense valve, leaks, or ruptured components can splash in the eyes or on skin and cause serious injury.

- Follow **Pressure Relief Procedure** in this manual, when you stop spraying and before cleaning, checking, or servicing equipment.
- Tighten all fluid connections before operating the equipment.
- Check hoses, tubes, and couplings daily. Replace worn or damaged parts immediately.

 **WARNING****PRESSURIZED ALUMINUM PARTS HAZARD**

Do not use 1,1,1-trichloroethane, methylene chloride, other halogenated hydrocarbon solvents or fluids containing such solvents in pressurized aluminum equipment. Such use can cause serious chemical reaction and equipment rupture, and result in death, serious injury, and property damage.

Overall View

Model GX-7A

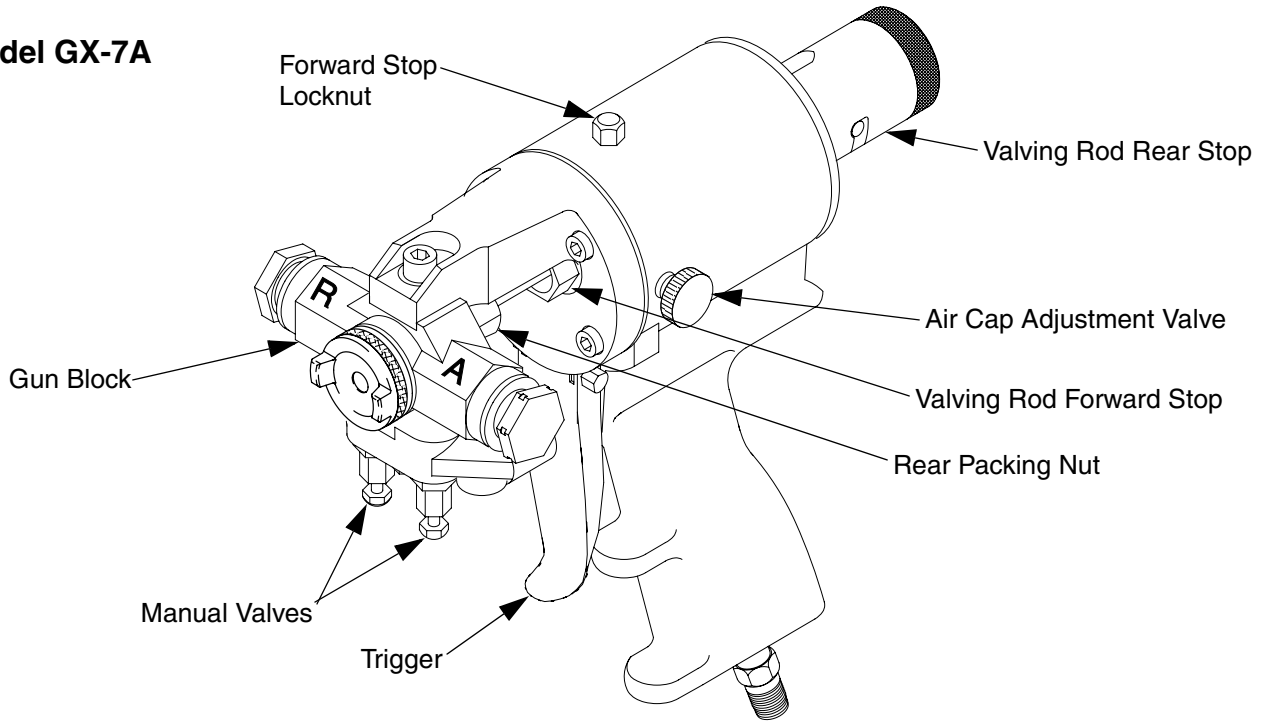

FIG. 1: GX-7A Overall View

Model GX-7 DI

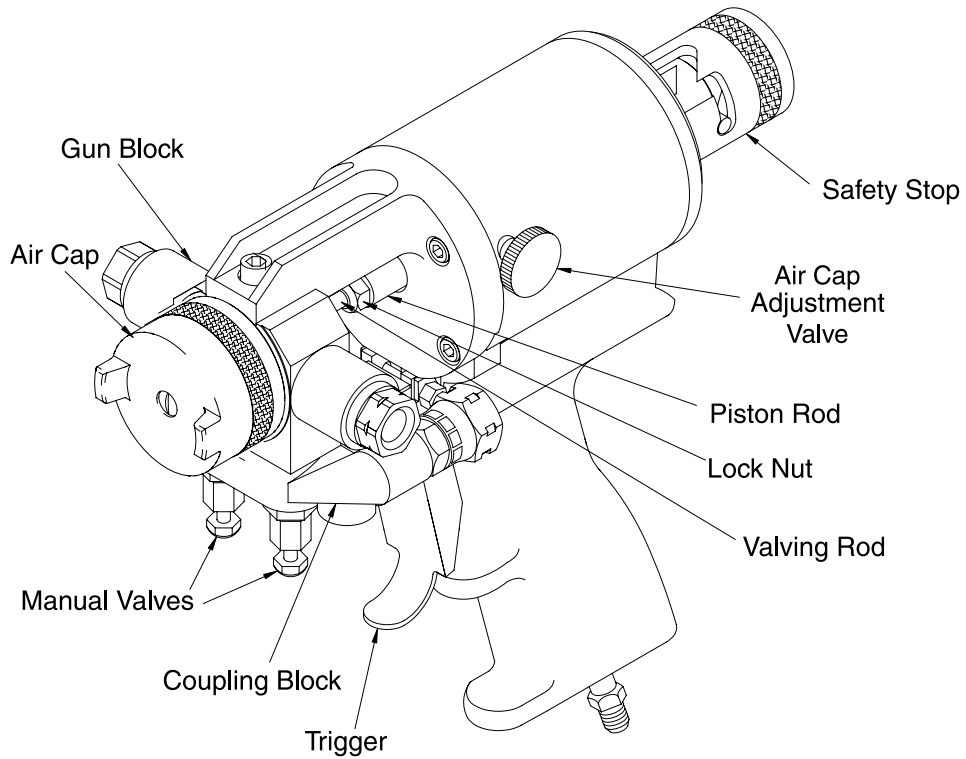

FIG. 2: GX-7 DI Overall View

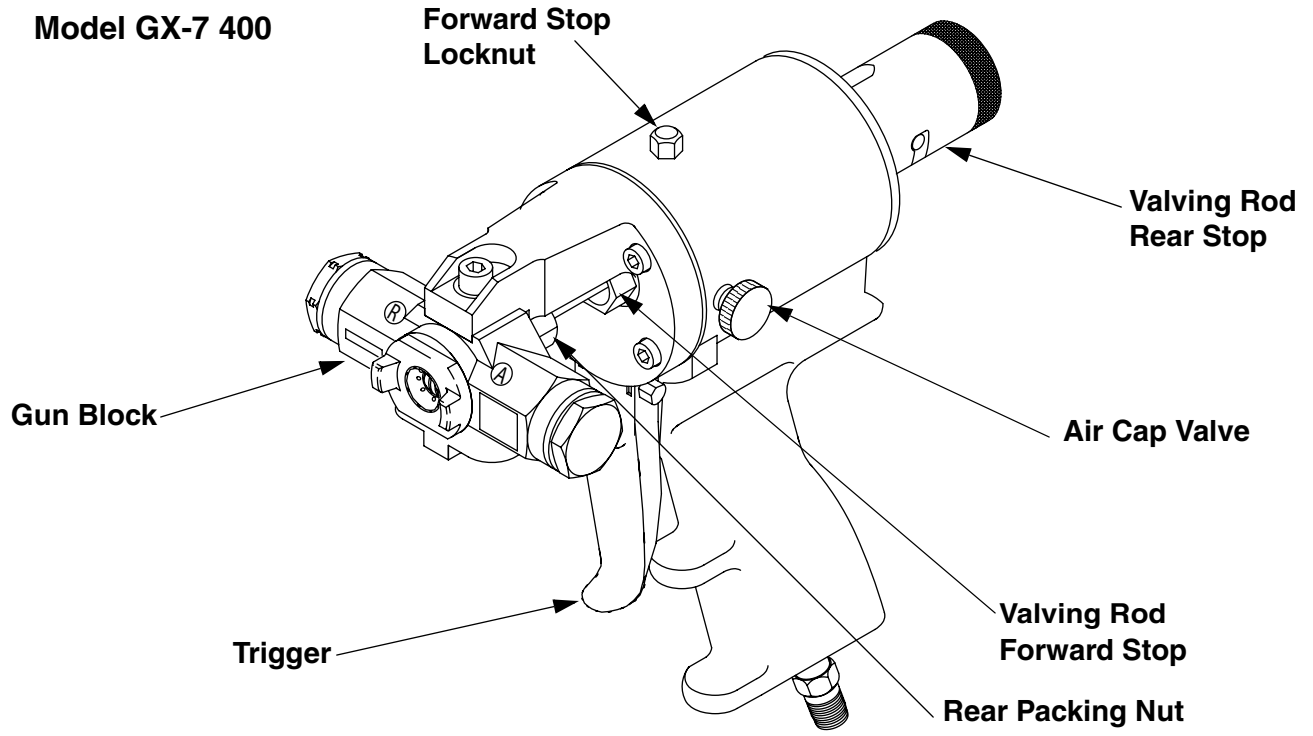

FIG. 3: GX-7 400 Overall View

Centerline Components

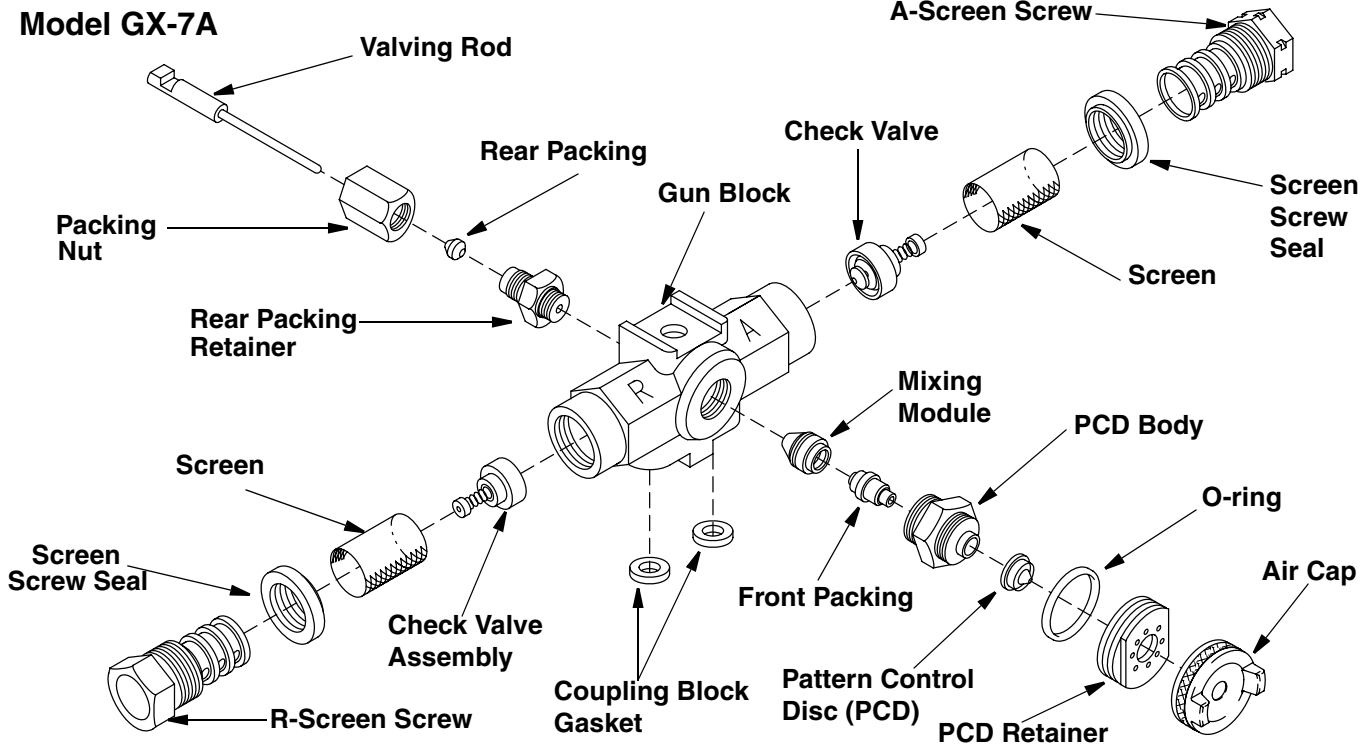

FIG. 4: GX-7A Centerline Components

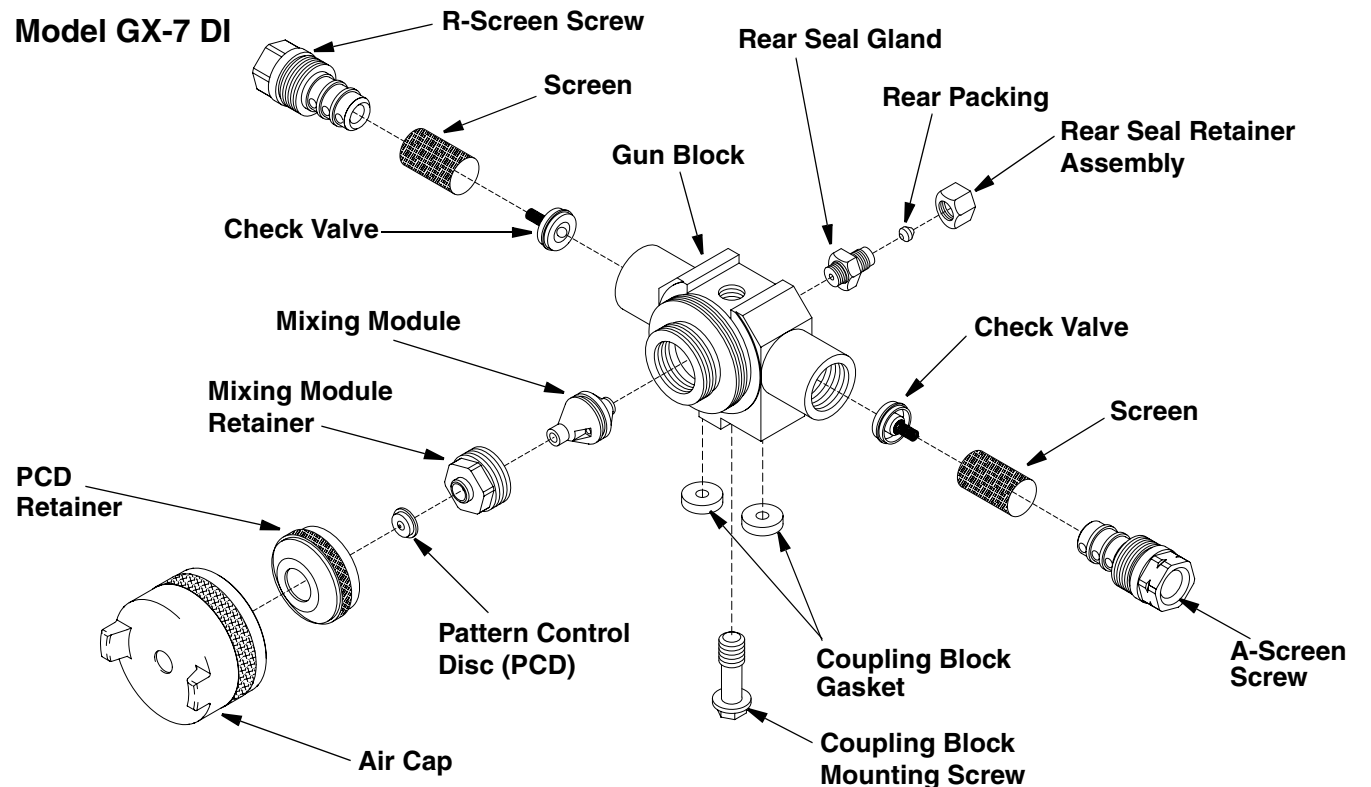

FIG. 5: GX-7 DI Centerline Components

Model GX-7 400

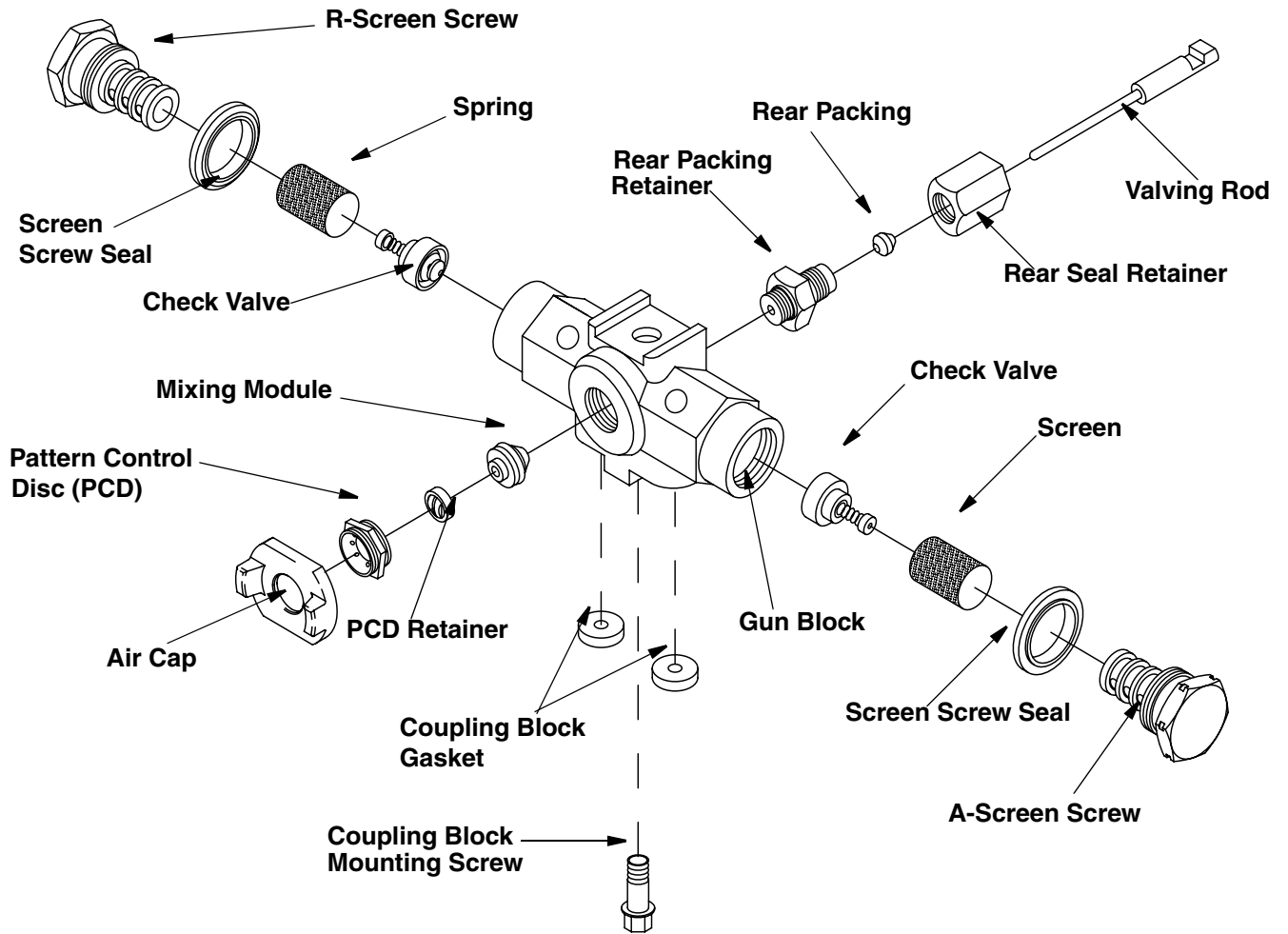

FIG. 6: GX-7 400 Centerline Components

Mixing Module

All gun models employ the concept of impingement mixing through the use of a single-part MIXING MODULE. This system is cleaned by a mechanical self-cleaning process, eliminating the need for solvent or air purging between dispenses.

The gun can be assembled with two styles of mixing components; their selection is dependent upon the type of system sprayed. The Set-Up Charts on pages 44 and 46 show several of the more common sets of these configurations.

The Mixing Module, in combination with a Pattern Control Disc (PCD), produce a thoroughly mixed chemical and reliable spray patterns. The module can be set up to spray at its maximum rated output. Additionally, by changing to a smaller PCD the module can spray at the low outputs and pressures that are required for detail work.

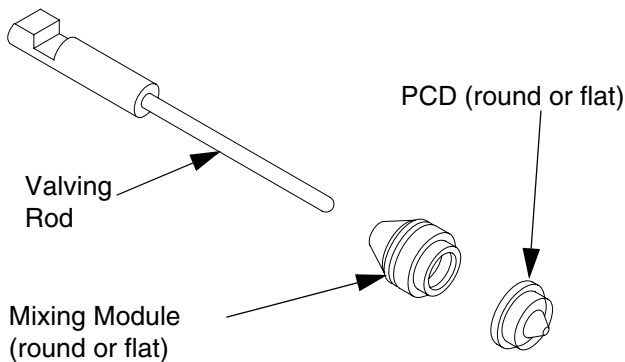

FIG. 7: GX-7A Mixing Module

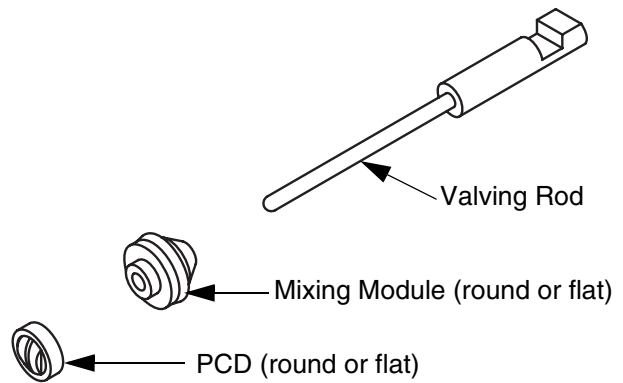

FIG. 8: GX-7 400 Mixing Module

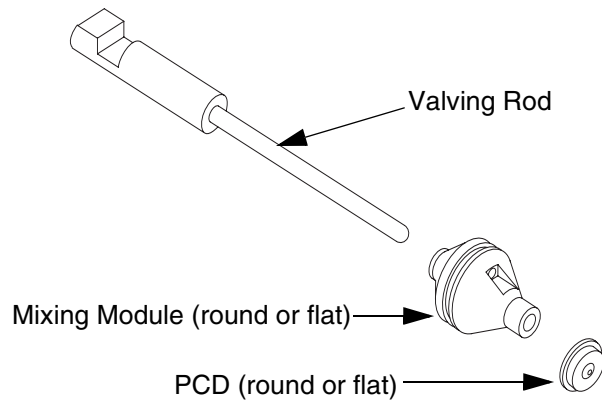







FIG. 9: GX-7 DI Mixing Module

Operation Basics

| | | | | | | |
|--|---|---|---|---|--|--|
|  |  |  |  |  | | |
| To prevent accidental gun operation, always disconnect air supply before servicing gun or anytime gun is not in use. | | | | | | |



Isocyanate Hazard

| | | | | | | |
|--|---|---|---|---|--|--|
|  |  |  |  |  | | |
| <p>Spraying materials containing isocyanates creates potentially harmful mists, vapors, and atomized particulates.</p> <p>Read material manufacturer's warnings and material MSDS to know specific hazards and precautions related to isocyanates.</p> <p>Prevent inhalation of isocyanate mists, vapors, and atomized particulates by providing sufficient ventilation in the work area. If sufficient ventilation is not available, a supplied-air respirator is required for everyone in the work area.</p> <p>To prevent contact with isocyanates, appropriate personal protective equipment, including chemically impermeable gloves, boots, aprons, and goggles, is also required for everyone in the work area.</p> | | | | | | |

Keep A and B Components Separate

| CAUTION |
|--|
| To prevent cross-contamination of the gun's wetted parts, do not interchange A component (isocyanate) and B component (resin) parts. The gun is shipped with the A side on the left. |

Grounding

| | | | | | | |
|---|--|--|--|--|--|--|
|  |  | | | | | |
|---|--|--|--|--|--|--|

Check your local electrical code and proportioner manual for detailed grounding instructions.

Ground the spray gun through connection to a Graco-approved grounded fluid supply hose.

Safety Position

The guns have a two-position valving rod rear stop. The SERVICE position allows for minimal rearward travel of valving rod but will not allow chemical to discharge. The OPEN position allows full rearward travel of valving rod and permits gun to dispense. Whenever gun is not spraying, set to SERVICE position.

Engage Safety Stop

To engage safety stop, push in and turn safety stop clockwise to place gun in CLOSED (SERVICE) position.

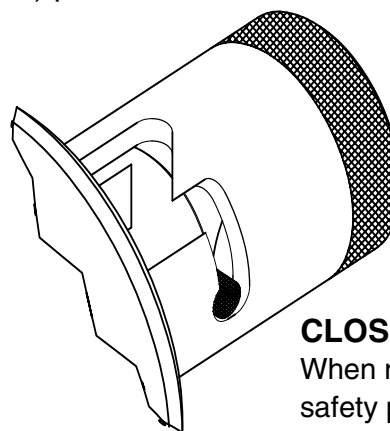

FIG. 10: Safety Stop - Closed

Disengage Safety Stop

To disengage safety stop, push in and turn safety stop counterclockwise to place gun in OPEN position (red band is exposed).

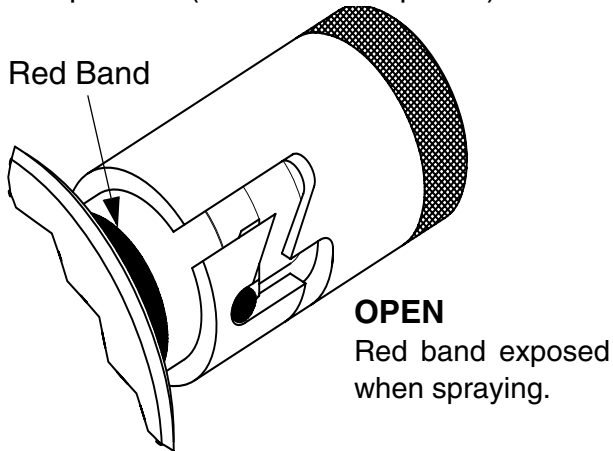

FIG. 11: Safety Stop - Open

Close Manual Valves

Closing manual valves prevents chemicals in heated hoses from entering gun. For your own safety, close manual valves before servicing gun.

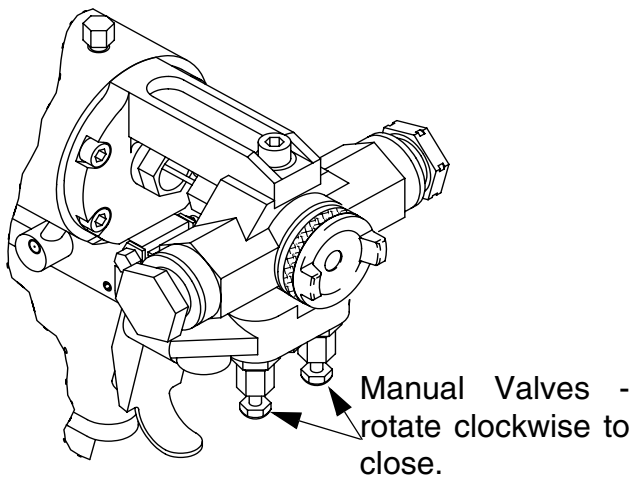

FIG. 12: Close Manual Valves

Air Hose Connection

Connect Air Hoses

Pull back sleeve of female fitting, insert male fitting and slide sleeve forward to secure connection.

Disconnect Air Hoses

Pull back sleeve of female fitting and pull out male fitting.

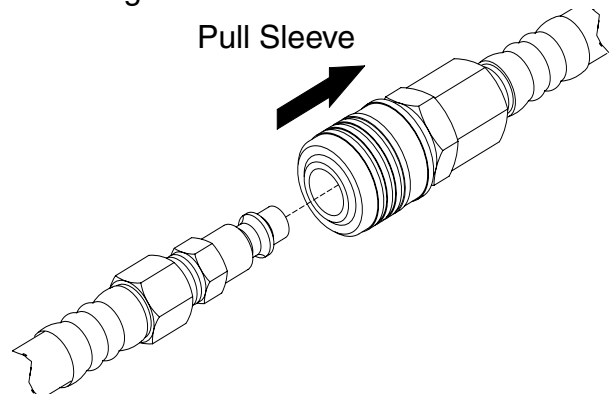



FIG. 13: Disconnect Air Hose





Coupling Block

Chemical hoses are joined to gun block by coupling block to ease installation and removal of gun.

Manual Valves

Two manual valves located on coupling block control flow of each chemical component to gun.

 Triggering gun with manual valves closed may cause crossover if any residual chemical remains in gun ports.

| | | | | | | |
|---|---|---|---|---|--|--|
|  |  |  |  |  | | |
| Never open manual valve unless coupling block is secured to gun or unless you point gun into waste container. | | | | | | |

Open Manual Valves

Use 5/16 in. nut driver to turn manual valve counterclockwise three full turns.

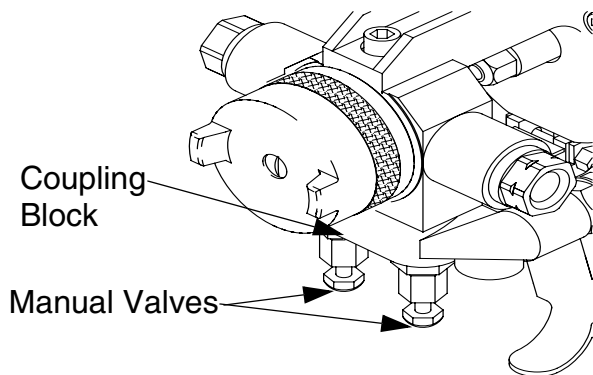







FIG. 14: Open Manual Valves

Close Manual Valves

Use 5/16 in. nut driver to turn manual valve fully clockwise.

| CAUTION | |
|---|--|
| To prevent accidental gun operation, always set safety stop to CLOSED (SERVICE), close both manual valves, and disconnect air supply. | |

Installation and Removal

| | | | | | | |
|---|--|---|---|---|--|--|
|  |  |  |  |  | | |
| To prevent release of pressurized chemicals, close both manual valves before removing coupling block. | | | | | | |

Install Coupling Block

1. Replace nicked, damaged, or worn coupling block gaskets.
2. With gaskets in place, fit coupling block to gun block.

3. Insert coupling block mounting screw and use 5/16 in. nut driver to tighten to gun block.

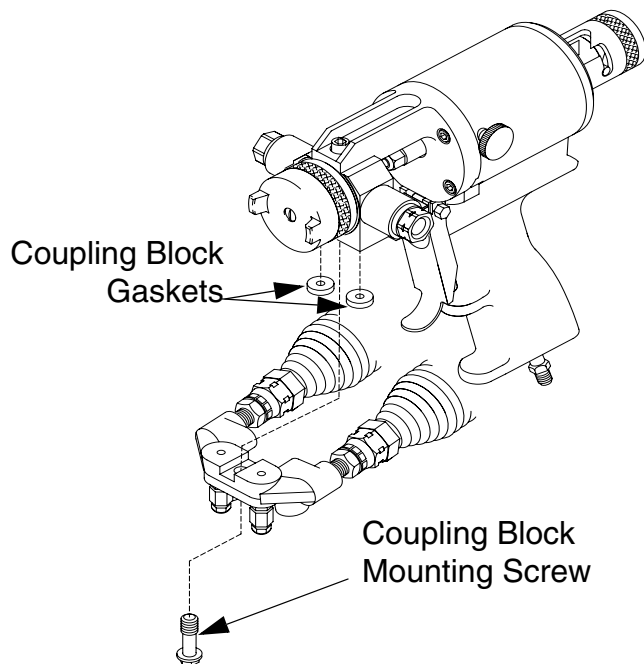

FIG. 15: Install Coupling Block

Remove Coupling Block

1. Set safety stop to CLOSED (SERVICE).
2. Disconnect air hose.
3. Close both manual valves.
4. Remove coupling block mounting screw.
5. Separate coupling block from gun.
6. Wipe mating surfaces of gun block and coupling block to remove residual chemical.
7. Cover exposed openings with grease.

Optional Configuration

Refer to page 42. If bottom-mount hose connection is desired, alternate swivel fitting (2 and 3) with pipe plugs (1). Use pipe thread sealant. Do not cross-over which side each fitting is on.

Air Inlet Configuration

There are two configurations for the air inlet. In the standard configuration the air inlet is at the base of the handle, and in the alternate configuration the air inlet is at the rear of the gun.

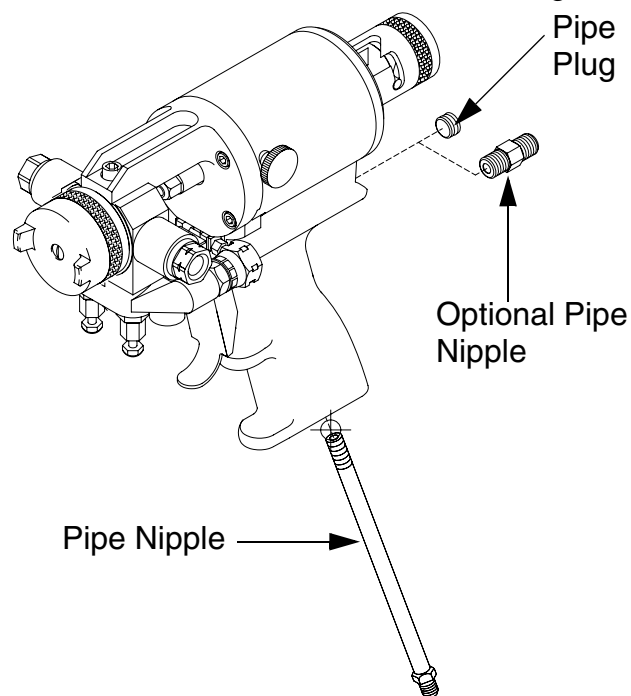

FIG. 16: Air Inlet Configuration

To change to alternate configuration,

1. Remove pipe nipple.
2. Remove pipe plug from rear of gun.
3. Install pipe plug in location previously occupied by pipe nipple.
4. Install pipe nipple in location previously occupied by pipe plug.

Mixing Module and PCD Installation

1. Install mixing module:
 - a. Disconnect gun from coupling block.
 - b. Connect air supply to gun.
 - c. Set safety stop to OPEN.
 - d. Hold down trigger and place module over tip of valving rod.
 - e. Align keying pin with hole in gun block and push in firmly (GX-7 DI model only).
 - f. Install front packing into module retainer (GX-7 model only).
 - g. Install module retainer, hand tight. Release trigger.
 - h. Use wrench to strongly tighten module retainer (250 in.-lbs.).
GX-7 DI model only: use wrench to tighten module retainer (150 in.-lbs.).
DO NOT OVERTIGHTEN.
2. Install PCD:
 - a. Disconnect air supply from gun.
 - b. Loosen forward stop screw (GX-7 model only).
 - c. Turn forward stop nut clockwise (as viewed from front of gun) 1-2 turns (GX-7 model only).
 - d. Slightly loosen rear seal retainer assembly.
 - e. Remove safety stop.
 - f. Use wrench to loosen piston locknut. Turn valving rod rearward as far as it will turn.
 - g. Place and orient PCD over mixing module retainer.
 - h. Install PCD retainer and hand tighten (GX-7 DI model only).
 - i. Install PCD retainer and wrench tighten (GX-7 model only).
3. Adjust valving rod. See procedure for appropriate gun model.
4. Set safety stop to OPEN position.
5. Check adjustment of valving rod:
 - a. With air supply connected, hold down gun trigger and loosen PCD retainer. Release trigger.
 - b. Hand tighten PCD retainer.
 - c. While maintaining tightening torque, trigger gun. Retainer should rotate approximately 1/10 of turn.
 - d. Release trigger.

Valving Rod Adjustment

GX-7A and GX-7 400 Models Only

1. Push in rear stop to SERVICE position.
2. If attached, turn both manual valves fully clockwise to close (see **Manual Valves**, page 13).
3. Connect air line from gun to air source to pressurize air cylinder forward to CLOSED position.
4. Loosen forward stop locknut.

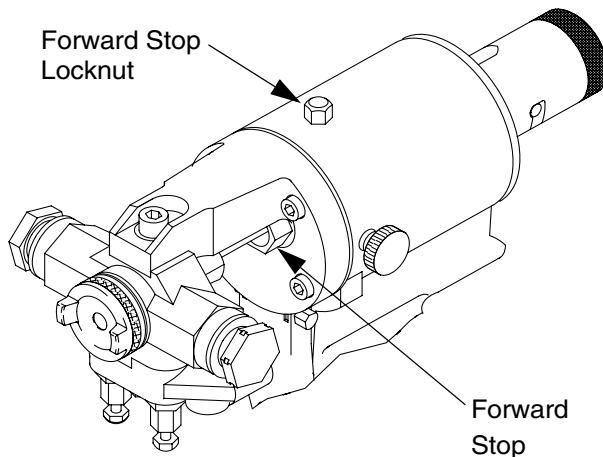

FIG. 17: Forward Stop

5. Completely loosen (full CCW) forward stop. Then slowly tighten (CW) forward stop until a snug resistance is felt. From this point, reverse and loosen approximately 1/16 of a turn.
6. Tighten forward stop locknut. Do not over-tighten. If locknut bottoms out before resistance is felt, replace friction plug.

 As a reference point, movement of one wrench flat corresponds to 1/6 turn.



FIG. 18: One Wrench Flat

Valving Rod Adjustment

GX-7 DI Model Only

Valving rod requires adjustment in only the following instances:

- disassembly and service of air cylinder
- changing valving rod
- changing mixing module

1. Clean gun according to **Clean Spray Gun Procedure**, page 20.
2. Connect air supply to gun.
3. Loosen rear seal retainer assembly one or two turns.
4. Loosen locknut from valving rod three or four turns.
5. Set safety stop to OPEN.
6. Use 5/16 in. nut driver through rear of gun to thread valving rod forward to engage PCD. When valving rod contacts PCD tighten another 1/10 turn.
7. Carefully maintain position of valving rod and tighten locknut against piston rod.
8. Retighten rear seal retainer assembly.

Initial Set Up



1. Install female quick disconnect fitting to air supply hose bundled with chemical supply hoses.
2. Connect coupling block to hose bundle. Connect A-Isocyanate hose (red-tape) to notched fitting on coupling block. Connect R-Resin hose (blue-tape) to fitting without notches on coupling block.
3. Close both manual valves.
4. Pressurize A and R chemical hoses. Check for leaks. See Proportioner manual.
5. Bleed air from chemical hoses.
 - a. Use separate waste containers for A-ISO and R-Resin.
 - b. Hold coupling block with exit ports pointed into waste container.
 - c. Open one manual valve at a time to dispense into waste container.
 - d. Bleed each side until chemical leaving hoses is free of air.
 - e. Close both manual valves.
6. Use cloth soaked in gun cleaner to clean coupling block and mating surfaces.
7. Set safety stop to CLOSED (SERVICE).
8. Install coupling block to gun.
9. Proceed with daily start-up and shutdown procedures.

Daily Start-up



Ensure gun is attached to coupling block and air hose. Ensure proportioning unit is at desired temperature and pressure. Properly ground equipment to avoid static sparking that may result in fire or explosion.

1. Connect air supply to gun.
2. Adjust air cap adjustment valve. Turn knob counterclockwise to open valve and clockwise to close valve
3. Adjust rear seal retainer.
4. Open both manual valves. See **Coupling Block** section, page 13.
5. Set safety stop to OPEN.
6. Test spray on disposable surface.

Daily Shutdown







 Follow daily shutdown procedure when gun is out of service for any length of time, or for mid- or end-of-day service. See **Clean Spray Gun Procedure**, page 20.

1. Set safety stop to OPEN.
2. Close both manual valves.
3. Disconnect air supply from gun.
4. Shutdown proportioning unit as required. See Proportioner manual.
5. Clean as required. See **Clean Spray Gun Procedure**, page 20.

 Do not disassemble gun daily for cleaning if it is operating properly. However, if gun is removed from coupling block, it must be flushed and cleaned thoroughly.

Pressure Relief Procedure

| | | | | | | |
|---|---|---|---|--|--|--|
|  |  |  |  | | | |
| Relieve pressure before cleaning or repairing gun. | | | | | | |

1. Close both manual valves.

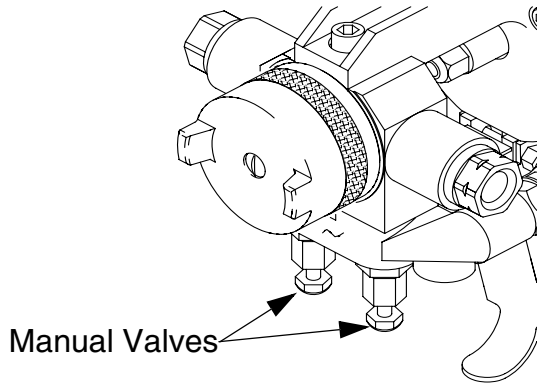

FIG. 19: Close Manual Valves

2. Set safety stop to OPEN.
3. Trigger gun onto cardboard or into waste container to relieve pressure.

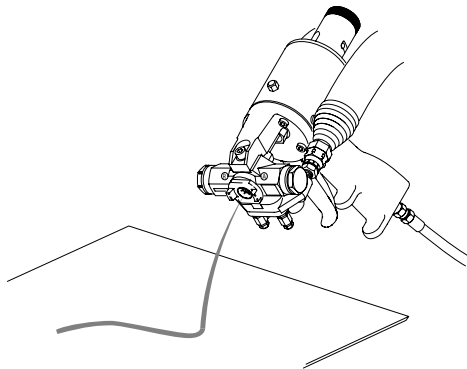

FIG. 20: Trigger Gun

4. Release gun trigger, set safety stop to CLOSED, and close manual valves.





| | | | | | | |
|---|--|---|---|--|--|--|
|  |  |  |  | | | |
| If fluid in hose and proportioner is still under pressure, follow Pressure Relief Procedure in proportioner manual | | | | | | |
| To relieve pressure in hose after gun is removed, place fluid manifold over containers, facing away from you. Very carefully open fluid valves. Under high pressure, fluid will spray sideways from fluid ports. See FIG. 21. | | | | | | |



FIG. 21: Open Manual Valves

Maintenance

Gun Service Kits

Use either the 1-Quart Gun Service Kit (296980) or 3-Gallon Gun Service Kit (296981) to perform daily flushing of spray gun without disassembly.

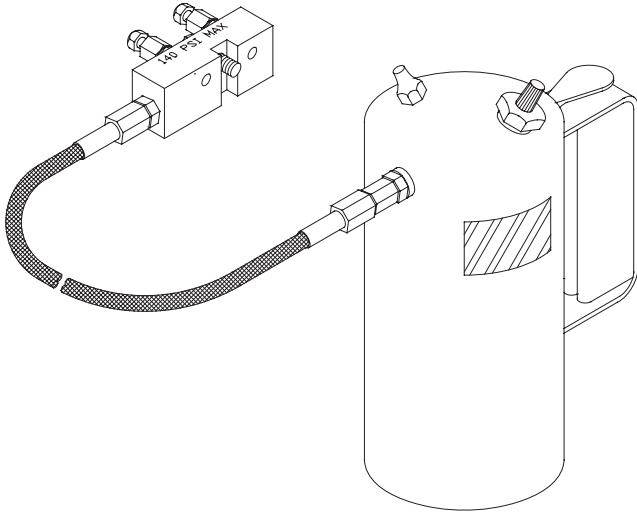

FIG. 22: 1-Quart Gun Service Kit
For more information about the 1-Quart Gun Service Kit, see Manual 311340.

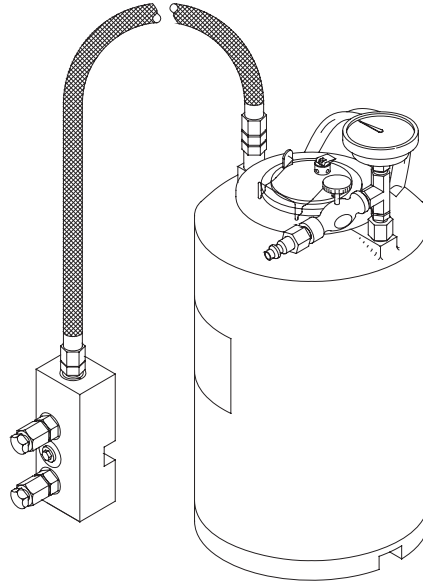

FIG. 23: 3-Gallon Gun Service Kit
For more information about the 3-Gallon Gun Service Kit, see Manual 311341.

Clean Spray Gun Procedure



To avoid static sparking that may result in fire or explosion, ensure all equipment in cleaning procedure is grounded. Do not clean on or near foamed or coated surfaces or any other flammable surfaces or objects.

Thoroughly flush gun block with gun cleaner before removing valving rod or mixing components from gun block. Also allow chemicals in spray gun to cool before cleaning.

This procedure makes use of the 1-Quart or 3-Gallon Gun Service Kit.

1. Set safety stop to CLOSED (SERVICE).



2. Close both manual valves.
3. Remove gun from coupling block.
4. Attach service block of gun service kit to spray gun, and then tighten using 5/16 in. nut driver.
5. Pressurize Service Kit container up to 100 psi. **DO NOT EXCEED 100 psi (0.7 MPa, 7 bar).**
6. Open one manual valve on service block.
7. Connect air to gun. Set safety stop to OPEN.
8. Hold gun against grounded waste container.
9. Trigger gun and 1-Quart Gun Service Kit. Spray into waste container until there is a fine, unobstructed mist of gun cleaner.
10. Release both triggers and close manual valve on service block.
11. Repeat steps 5-7 for other side of gun.
12. After initial cleaning, remove air cap, PCD retainer, and PCD. Flush a second time to ensure thorough cleaning.
13. Remove service block of gun service kit from spray gun.
14. Set safety to CLOSED (SERVICE).
15. Disconnect air supply.

16. Clean screens, check valves and screen screw as required. See **Service Screen Screw**, page 22.

 Inspect air cap, PCD, mixing module, and gun block for build up of material and clean as required.





Do not use metal cleaning devices to clean plastic components.

Flush Gun

| | | | | | | |
|---|--|---|--|--|--|--|
|  |  |  | | | | |
| To avoid static sparking that may result in fire or explosion, ensure all equipment in flushing procedure is grounded. Do not flush on or near foamed or coated surfaces. | | | | | | |

1. Set safety stop to CLOSED (SERVICE).
2. Close both manual valves.
3. Loosen R-Screen screw and then remove by hand.
4. Use flush can to thoroughly flush screen screw and screen screw cavity.
5. Loosen A-Screen screw and then remove by hand.
6. Use flush can to thoroughly flush screen screw and screen screw cavity.
7. Service gun by following **Maintenance** procedures, page 20.

Repair

| | | | | | | |
|---|---|---|---|--|--|--|
|  |  |  |  | | | |
| <p>Shutdown proportioner and allow chemicals to cool before servicing gun.</p> <p>Clean A and R components in separate containers to avoid cross contamination.</p> | | | | | | |

Service Screen Screw

1. Flush gun according to **Clean Spray Gun Procedure**, page 20.
2. Unthread screen screw from gun block.
3. Remove check valve from screen screw. Clean valve with gun cleaner and inspect for damage. Replace if necessary.
4. Remove screen from screen screw. Soak in gun cleaner or replace if clogged or dirty.
5. Clean screen screw cavity. If **any** particles are visible, clean with clean out drills and flush with gun cleaner.

| CAUTION |
|---|
| Any material left in cavity on downstream side of screen will clog mixing module. |

6. Inspect screen screw seal for damage. Replace if necessary.
7. Reinstall screen screw in gun block. Make sure it is tight.
8. Flush gun with mixing module removed.

Remove Centerline Components

Refer to FIG. 4 through FIG. 6 for diagrams of centerline components for all gun models.

1. Flush gun according to **Clean Spray Gun Procedure**, page 20.
2. Connect air supply to gun. Set safety stop to OPEN.
3. Remove air cap.
4. Trigger gun and hold it to relieve pressure on PCD retainer.
5. Remove PCD retainer by turning it counterclockwise.
6. Remove PCD from mixing module retainer.

 To remove PCD that is stuck, set safety stop to OPEN, depress and release gun trigger to unseat it. Set safety stop to CLOSED (SERVICE).

7. Remove mixing module retainer.
8. Set safety stop to OPEN. Depress and release gun trigger to unseat it. Remove mixing module off end of valving rod. Set safety stop to CLOSED (SERVICE).

| CAUTION |
|--|
| Do not use sharp objects or metal tools to remove mixing module. |

9. Loosen rear packing nut 1-2 turns.
10. Push safety stop partially forward, rotate it counterclockwise, and slide off air cylinder.

11. Remove valving rod.

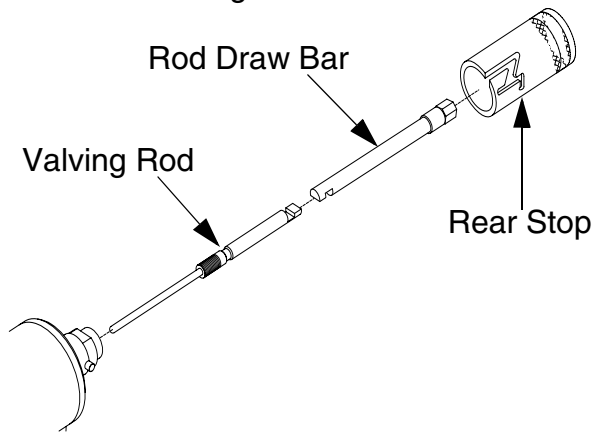
**FIG. 24: Remove Valving Rod**

- a. Depress trigger lever and hold.
GX-7 DI model only: loosen piston stop locknut until it disengages from thread on valving rod.
- b. Use 5/16 in. nut driver to unthread rod draw bar and valving rod from rear of gun.
- c. When threads disengage remove assembly by hand.

12. Inspect valving rod for damage and replace as required. Clean and remove any buildup of mixed material from rod using cloth soaked in gun cleaner or fine steel wool.



If valving rod is replaced, it is recommended to reset forward stop.

13. Disconnect air supply.

14. Remove gun block retaining screw. Carefully slide gun block away from air cylinder. If dried chemical is built up on gun block, remove dried chemical before you remove gun block.

15. Clean all components thoroughly. Use brushes and clean-out tools to remove

residual chemical from metal components. Use cotton swabs soaked in gun cleaner to clean plastic components.

16. Coat threads and mating surfaces of gun block and gun block bracket with Lubriplate grease, and reassemble.

17. Inspect gun block for damage.

Install Centerline Components

GX-7 DI Model Only

Before installation, ensure all gun components are clean and dry. Lubricate all moving parts and threads.

1. Install rear packing gland with packing wrench. Tighten onto gun block.
2. Install rear packing retainer loosely.
3. Install valving rod.
 - a. Connect valving rod to rod draw bar and insert into air cylinder.
 - b. Use 5/16 in. nut driver to thread assembly tight into end cap.
GX-7 DI model only: thread rod until approximately 3/16 in. to 1/4 in. of thread protrudes from end of piston rod.
4. Thread locknut onto valving rod by hand.
5. Carefully slide gun block onto valving rod toward air cylinder. Install gun block onto gun block mounting bracket.
6. Install safety stop; leave in OPEN position.
7. Connect air supply to gun.
8. Depress gun trigger and slide mixing module over end of valving rod.
GX-7 DI model only: ensure valving rod alignment pin enters alignment slot in gun block.
 Keep gun trigger depressed.

9. With gun trigger depressed, thread mixing module retainer or PCD body with packing installed, by hand, and then wrench tighten.

| CAUTION |
|---|
| To avoid damage to module and gun block, do not overtighten mixing module retainer. |

10. Release gun trigger.
11. Install PCD over end of mixing module retainer.
12. Thread PCD retainer onto gun block. Hand tight.
13. Rotate flat PCD to adjust orientation as required.
14. Adjust valving rod. See **Valving Rod Adjustment**, page 16.
15. Thread air cap into place; hand tight.
16. Slide safety stop onto rear of air cylinder. Push safety stop partially forward and rotate clockwise to set to OPEN.
17. Set safety stop to CLOSED (SERVICE).

Replace End Cap and Air Piston Assembly

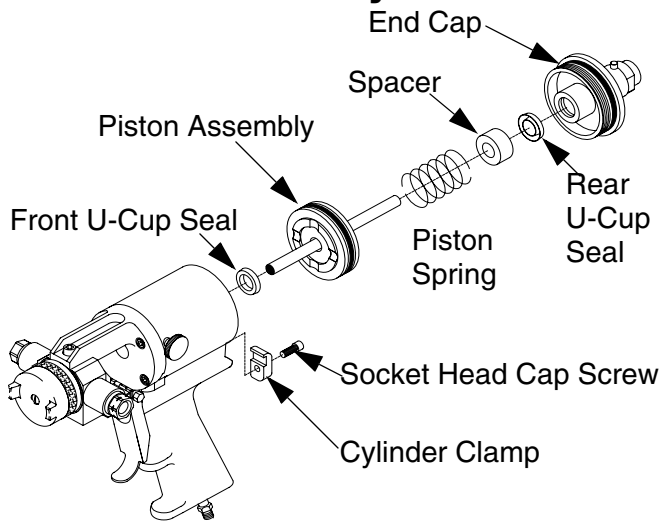

GX-7 DI Shown

FIG. 25: GX-7 DI End Cap and Air Piston Assembly

1. Clean gun according to **Clean Spray Gun Procedure**, page 20.
2. Loosen rear packing nut 1-2 turns.
3. Push safety stop partially forward, rotate counterclockwise, and slide safety stop off air cylinder.
4. Remove valving rod. See **Remove Center-line Components**, page 22.
5. Disconnect air supply from gun.
6. Remove rear head cap screw and cylinder clamp from handle.
7. Remove end cap from air cylinder.
8. Inspect end cap o-ring. Replace if damaged. Install new end cap o-ring after lightly coating it with Lubriplate grease.
9. Inspect rear U-cup seal or o-ring for damage. Replace if necessary. If removed, ensure “cup” faces front of air cylinder when replacing.
10. By hand, pull piston assembly out of air cylinder and inspect o-ring for damage. Replace if necessary. Apply Lubriplate grease prior to installation.
11. If air was escaping around piston rod during operation, replace front u-cup seal or o-ring. Apply Lubriplate grease and ensure “cup” faces rear of air cylinder.
12. Insert piston and rod assembly into air cylinder. Take care to not damage front cup seal as rod passes through.
13. Insert piston spring. (For GX-7 DI models, also insert piston spacer.)
14. Reinstall end cap into air cylinder.
15. Retighten rear socket head cap screw and cylinder clamp to handle.
16. Reinstall valving rod. Connect valving rod to draw bar. Lubricate and thread into end cap.
17. Adjust valving rod; see **Valving Rod Adjustment**, page 16.
18. Slide safety stop onto rear of air cylinder. Push safety stop partially forward and rotate clockwise to set to OPEN.
19. Set safety stop to CLOSED (SERVICE).
20. Tighten rear packing nut.

Replace Trigger Valve O-Rings

1. Clean gun according to **Clean Spray Gun Procedure**, page 20.
2. Disconnect air supply from gun. Refer to **Parts**, page 30.

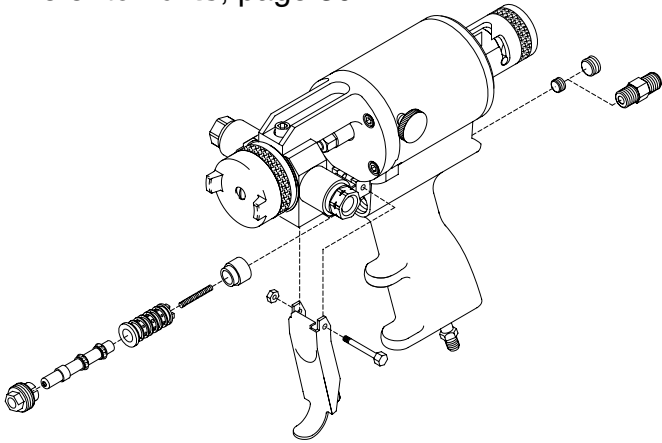



FIG. 26: Replace Trigger Valve O-Ring

3. Remove mounting screw and locknut that hold trigger in place. Remove trigger.
4. Remove valve retainer nut.
5. Pull out valve spool and valve spring. Remove old o-rings.
6. Prior to installation, liberally lubricate all o-rings with lubricant provided in Rebuild kit.

 Follow steps 7-15 to replace o-rings on valve liner. If o-rings do not need to be replaced, go to step 16.

7. Remove pipe plug from rear of gun handle.

 For guns configured with air inlet at rear of gun handle, pipe nipple replaces pipe plug. Remove pipe nipple.

8. Remove rear internal pipe plug (under pipe plug).
9. Use pin punch and hammer to gently tap spring seat until it and valve liner push out opposite end of hole.
10. Remove 4 o-rings on liner.
11. Apply thick coat of Lubriplate grease to new o-rings and install.
12. Clean valve hole. Remove any dirt and debris. Apply thick coat of Lubriplate grease to inside of valve hole.
13. Slide spring seat into gun handle air valve hole, tapered end first, until it bottoms out.
14. Push valve liner in as far as it will go. Temporarily screw in valve retainer nut, which aligns valve liner and valve spool. Remove valve retainer nut.
15. With valve spool spring in place, insert valve spool into valve liner. Screw in valve retainer nut. Do not overtighten.
16. Apply small amount of pipe thread sealant to 1/16 in. pipe plug threads. Screw pipe plug in place.
17. Apply small amount of pipe thread sealant to 1/8 in. pipe plug (or 1/8 in. pipe nipple) and install.
18. Reinstall trigger using screw and locknut.

Clean Mixing Module

1. Flush gun according to **Clean Spray Gun Procedure**, page 20.
2. Connect air supply to gun. Set safety stop to OPEN.
3. Remove air cap by hand.



 *GX-7A and GX-7 400 Models Only*
Air cap and PCD retainer may be difficult to separate during disassembly due to overtightening or hardened mixed material. Use retainer wrench to separate. When reinstalling, apply lubricant to threads.



FIG. 27: Unthread Cap from PCD Body

4. Trigger gun and hold it to relieve pressure on PCD retainer.
5. Remove PCD retainer by turning it counter-clockwise.
6. Remove PCD from mixing module retainer.

 To remove PCD that is stuck, set safety stop to OPEN, depress and release gun trigger to unseat it. Set safety stop to CLOSED (SERVICE).

7. Remove mixing module retainer.
8. Set safety stop to OPEN. Depress and release gun trigger to unseat it. Remove

mixing module from end of valving rod. Set safety stop to CLOSED (SERVICE).

9. Inspect valving rod for damage and replace as required. Use cloth soaked in gun cleaner or steel wool to clean and remove buildup of mixed material from rod.

 If the valving rod is replaced, reset forward stop.

10. Clean mixing module.

 Ensure cleanout tool size matches module size used. See the Set-Up Charts on pages 44 and 46.

- a. Insert cleanout tool into pin vise.
- b. Use cleanout tool to clean module ports. Take care not to insert tool too far causing damage to inside bore of module. Use cotton swab soaked in gun cleaner to clean bore of module.

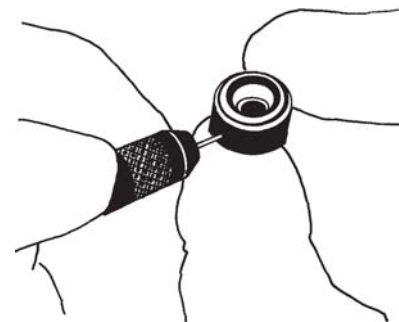

FIG. 28: Clean Module Ports

Install Mixing Module

1. Install safety stop; leave in OPEN position.
2. Connect air supply to gun.
3. Depress gun trigger and slide mixing module over end of valving rod.
GX-7 DI model only: ensure valving rod alignment pin enters alignment slot in gun block.
Keep gun trigger depressed.
4. With gun trigger depressed, thread mixing module retainer or PCD body with packing installed, by hand, and then wrench tighten.

| CAUTION |
|---|
| To avoid damage to module and gun block, do not overtighten mixing module retainer. |

5. Release gun trigger.
6. Install PCD over end of mixing module retainer.
7. Thread PCD retainer onto gun block. Hand tight.
8. Rotate flat PCD to adjust orientation as required.
9. Adjust valving rod. See **Valving Rod Adjustment**, page 16.
10. Thread air cap into place; hand tight.

11. Slide safety stop onto rear of air cylinder. Push safety stop partially forward and rotate clockwise to set to OPEN.

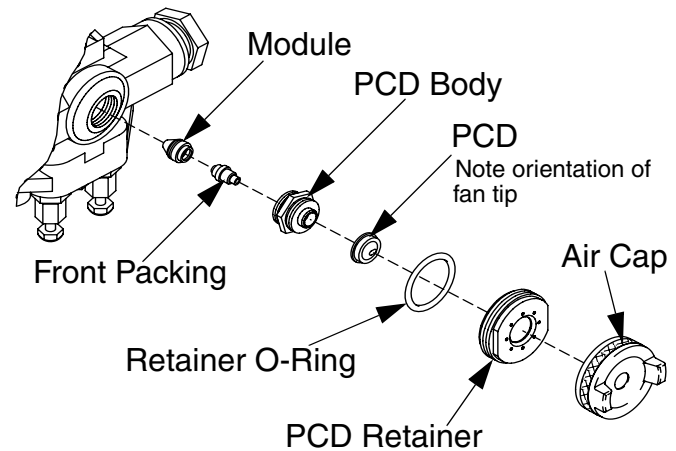

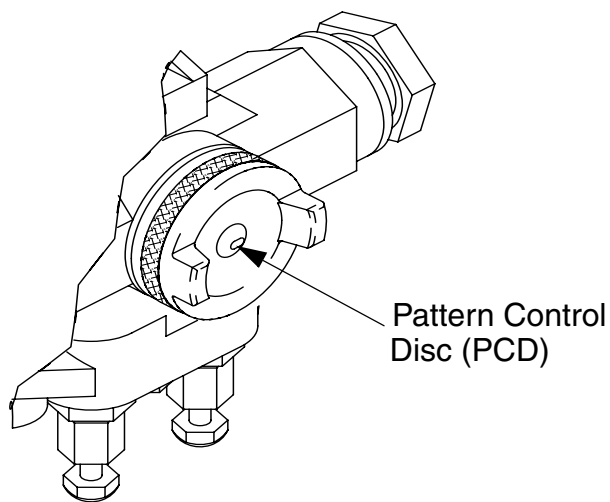

FIG. 29: Install Mixing Module

Clean Pattern Control Disc

1. Set safety stop to CLOSED (SERVICE).
2. Close both manual valves.
3. Turn off air to air cap.
4. Use cotton swab soaked in gun cleaner to clean external surface of material build up. Light scrubbing with impinger cleanout brush may also be required.
 - a. Trigger gun to SERVICE position and clean orifice area.

 It is not always possible to clean all material build-up from PCD while assembled to gun. In this case, remove PCD and clean inside radius of disc.



GX-7A Model Shown

FIG. 30: Pattern Control Disc (PCD)

Parts

GX-7A Model Final Assembly

Part Numbers 295542, 295543, 295544, 29545

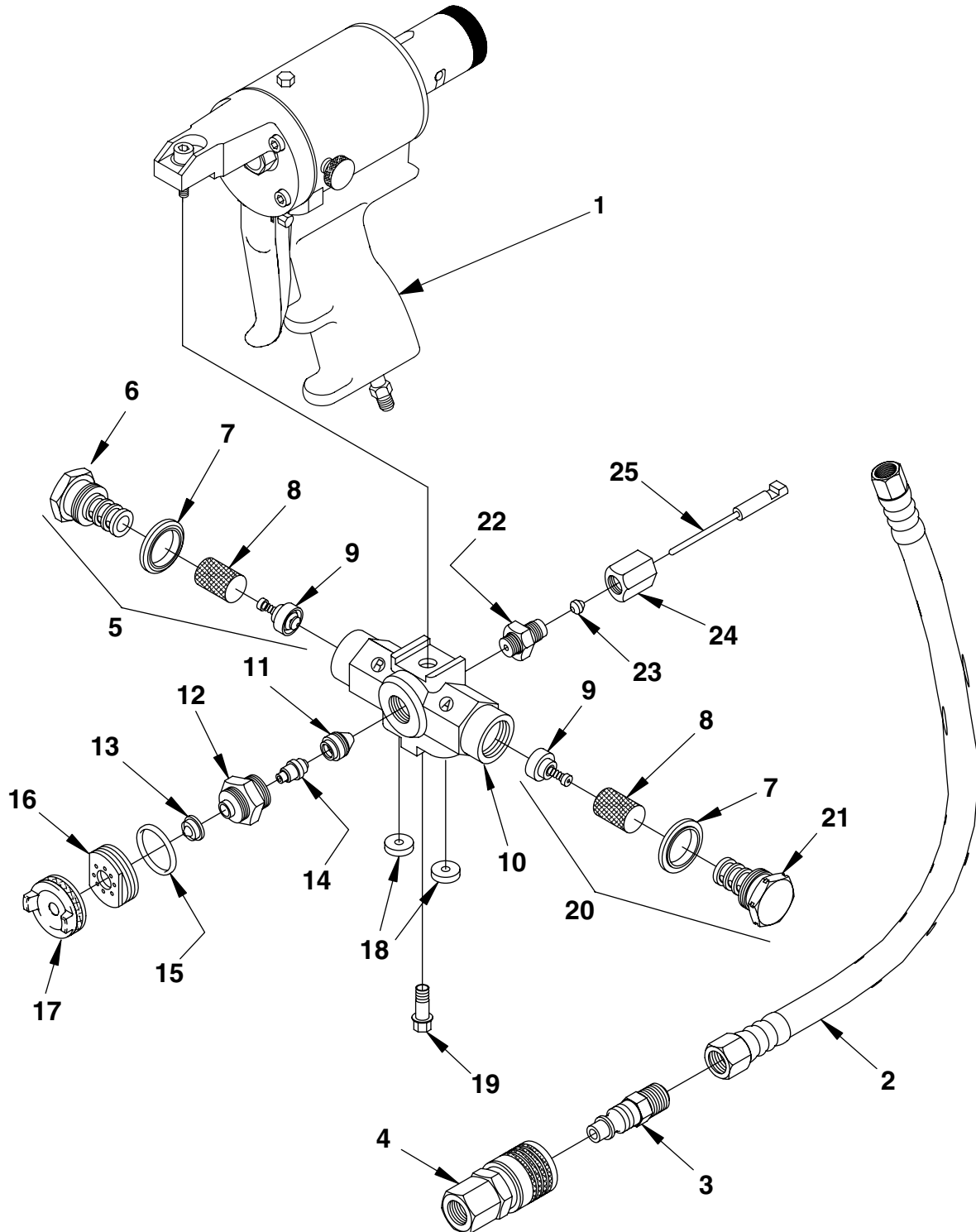

GX-7A Model Final Assembly

Part Numbers 295542, 295543, 295544, 295545

| Ref. | | | |
|------|----------|---|------|
| No. | Part No. | Description | Qty. |
| 1 | 295810 | Spray gun handle | 1 |
| 2 | 295184 | Air hose | 1 |
| 3 | 295596 | Coupler plug | 1 |
| 4 | 295597 | Coupler | 1 |
| 5 | 296834 | R-gun block screen screw assembly (includes 6, 7, 8, 9) | 1 |
| 6 | | R-gun block screen screw | 1 |
| 7 | 296693 | Screen screw seal (pack of 2) | - |
| 8† | | Screen, 80 mesh | - |
| 9 | 296722 | Check valve assembly (pack of 10) | - |
| 10 | 295384 | Gun block | 1 |
| 11 | | Module; see GX-7A Mix Mod- ule Kit , page 43 | 1 |
| 12 | 296976 | PCD body | 1 |
| 13 | | Tip; see Tip Kits , page 48 | 1 |
| 14 | 296978 | Front packing | 1 |
| 15 | 295868 | O-ring | 1 |
| 16 | 296832 | PCD retainer | 1 |
| 17 | 296831 | Air cap | 1 |
| 18 | 296128 | Coupling block gasket (pkg 2) | 1 |
| 19 | 296979 | Coupling block mounting screw (pkg 2) | 1 |
| 20 | 296833 | A-gun block screen screw assembly (includes 6, 8, 9, 21) | 1 |
| 21 | | A-gun block screen screw | 1 |
| 22 | 296828 | Rear packing retainer | 1 |
| 23 | 296829 | Rear seal packing (pack of 5) | - |
| 24 | 296830 | Rear seal retainer | 1 |
| 25 | 296692 | Valving rod | 1 |

† Screen Kit, 80 mesh; 296792 (pack of 10) and
296724 (pack of 50).

GX-7 DI Model Final Assembly (295541)

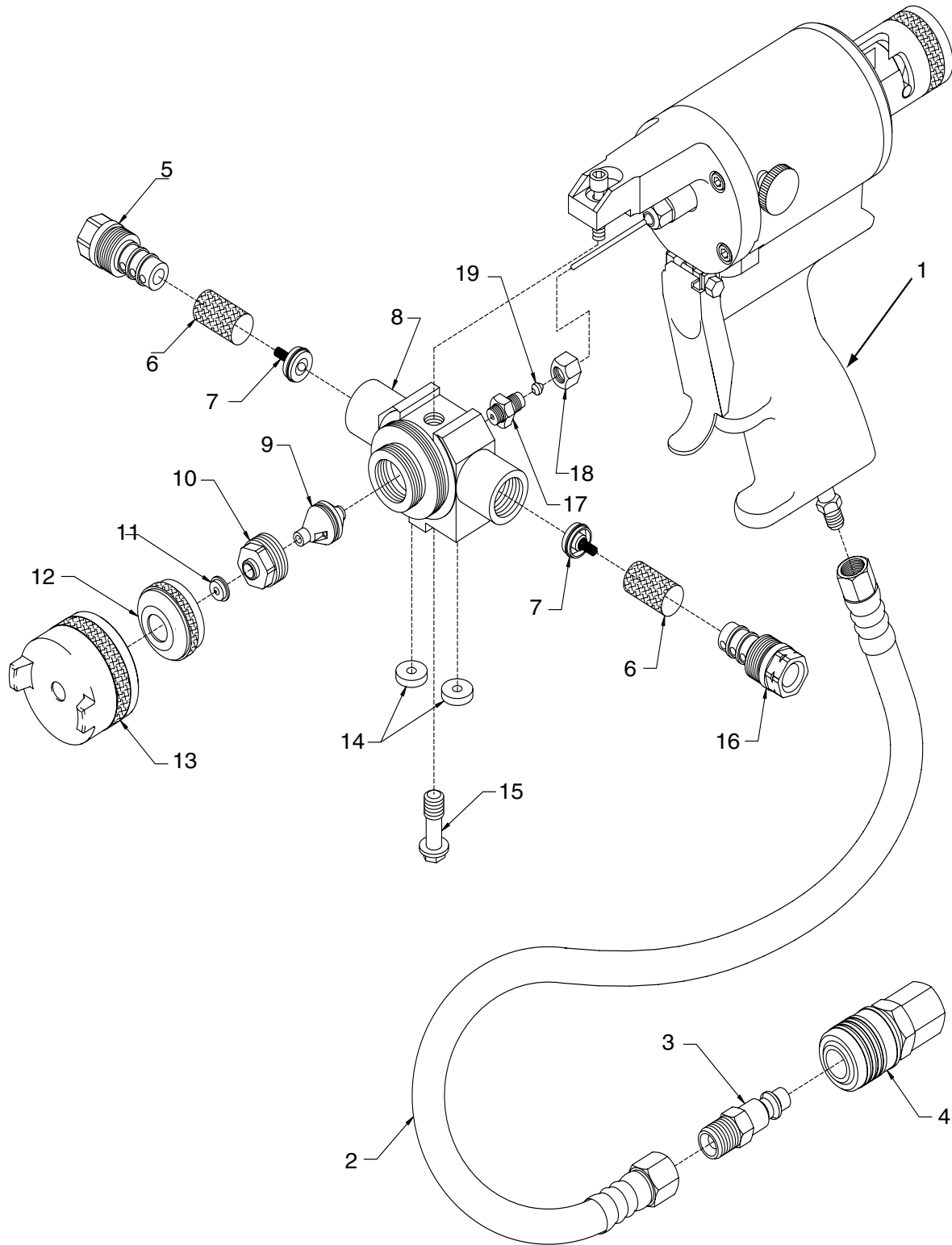

GX-7 DI Model Final Assembly (295541)

| Ref. | No. | Part No. | Description | Qty. |
|------|-----|----------|---|------|
| | 1 | 295809 | Spray gun handle assembly | 1 |
| | 2 | 295184 | Air hose, 1/4 in. x 23 in. (FXF) | 1 |
| | 3 | 295596 | Coupler plug | 1 |
| | 4 | 295597 | Coupler | 1 |
| | 5 | 295835 | R-screen screw | 1 |
| | 6† | | Screen, 80 mesh | - |
| | 7 | 296713 | Check valve assembly (pack of 2) | 2 |
| | 8 | 295860 | Gun block | 1 |
| | 9 | | Module; see GX-7 DI Model Specifications , page 47 | 1 |
| | 10 | 295837 | Module retainer | 1 |
| | 11 | | Tip; see Tip Kits , page 48 | 1 |
| | 12 | 296865 | Tip retainer | 1 |
| | 13 | 295838 | Air cap | 1 |
| | 14 | 296128 | Coupling block gasket (pack of 2) | - |
| | 15◆ | | Coupling block mounting screw | 1 |
| | 16 | 295834 | A-screen screw | 1 |
| | 17 | 295836 | Rear seal gland | 1 |
| | 18 | 296864 | Rear seal retainer assembly | 1 |
| | 19 | 296829 | Rear seal packing (pack of 5) | - |
| | 20 | 295383 | Coupling block (not shown) | 1 |

† Screen Kit, 80 mesh; 296792 (pack of 10) and 296724 (pack of 50).

◆ Coupling Block Screw Kit 296979 (includes pack of 2).

GX-7 400 Model Final Assembly (295540)

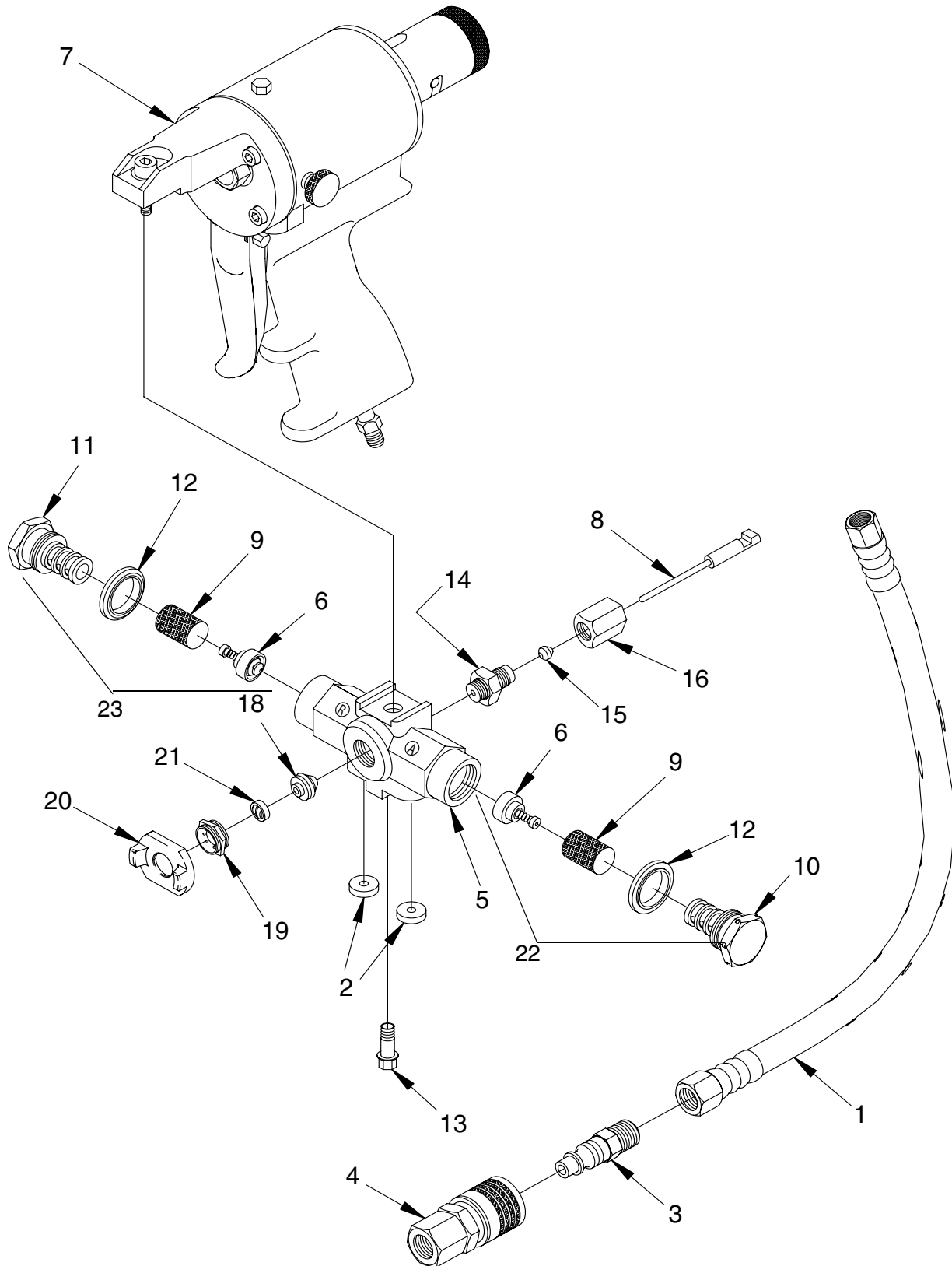

GX-7 400 Model Final Assembly (295540)

| Ref. | No. | Part No. | Description | Qty. |
|------|-----|----------|---|------|
| | 1 | 295184 | Air hose | 1 |
| | 2 | 296128 | Coupling block gasket (pack of 2) | - |
| | 3 | 295596 | Coupler plug | 1 |
| | 4 | 295597 | Coupler | 1 |
| | 5 | 295384 | Gun block (includes 13) | 1 |
| | 6 | 296722 | Check valve assembly (pack of 10) | - |
| | 7 | 295799 | Spray gun handle assembly | 1 |
| | 8 | 296692 | Valving rod | 2 |
| | 9† | | Screen-80, mesh | 2 |
| | 10 | | A-Screen screw | 1 |
| | 11 | | R-Screen screw | 1 |
| | 12 | 296693 | Screen screw seal (pack of 2) | - |
| | 13◆ | 295433 | Coupling block mounting screw | 1 |
| | 14 | 296828 | Rear packing retainer | 1 |
| | 15 | 296829 | Rear seal packing (pack of 5) | 1 |
| | 16 | 296830 | Rear seal retainer | 1 |
| | 18 | | Module; see GX-7 400 Mix Module Kit , page 45 | 1 |
| | 19 | 296836 | Retainer | 1 |
| | 20 | 296837 | Air cap | 1 |
| | 21 | | Tip; see Tip Kits , page 48 | 1 |
| | 22 | 296833 | A-gun block screen screw assembly (includes 6, 9, 10, 12) | - |
| | 23 | 296834 | R-gun block screen screw assembly (includes 6, 9, 10, 12) | - |

† Screen Kit, 80 mesh; 296792 (pack of 10) and
296724 (pack of 50).

◆ Coupling Block Screw Kit 296979 (includes pack
of 2).

GX-7A Model Handle Assembly (295810)

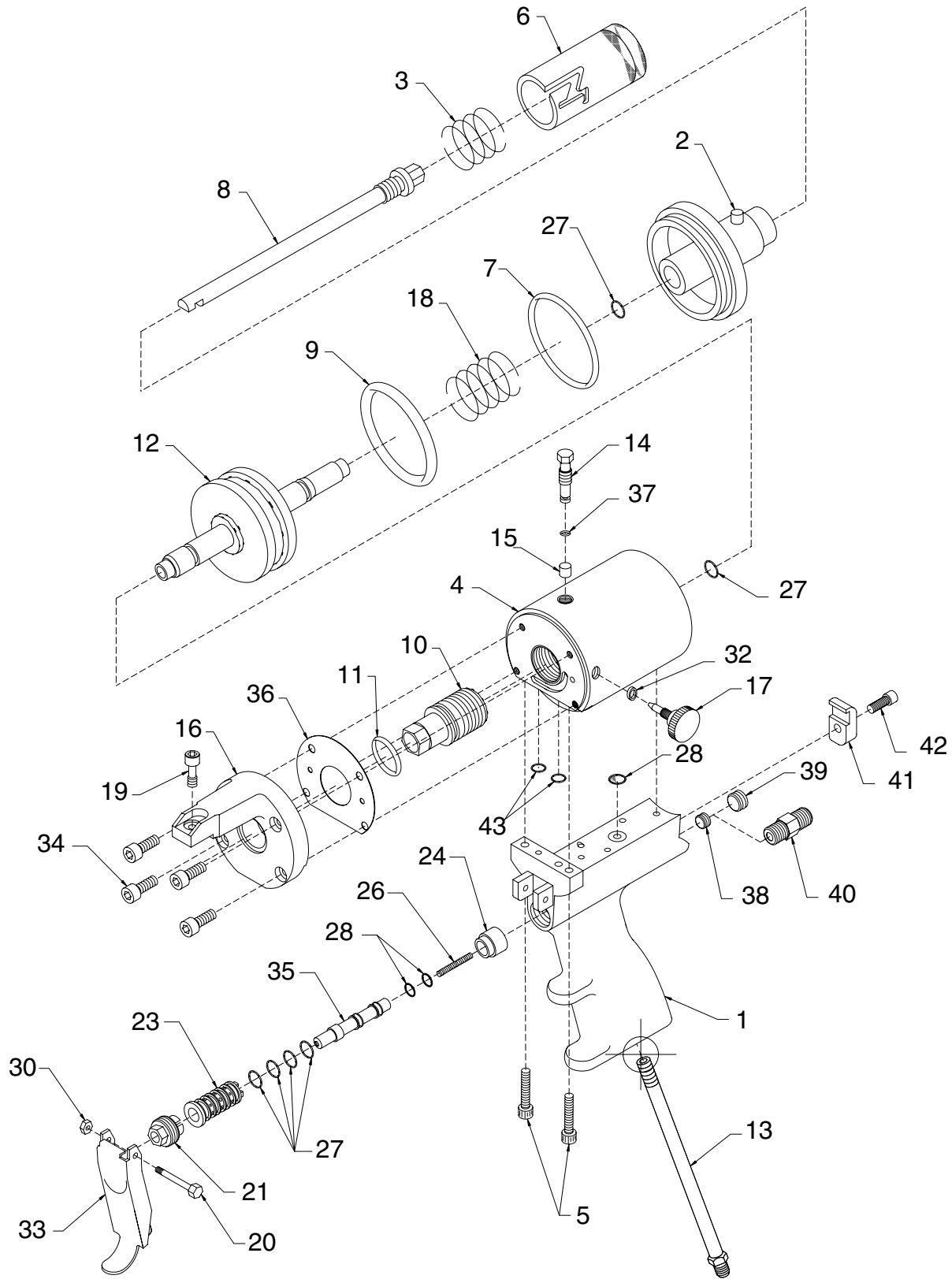

GX-7 Model Handle Assembly (295810)

| Ref. No. | Part No. | Description | Qty. | |
|-------------|----------|--|------|---|
| 1 | 296862 | Spray gun handle | 1 | † Parts included in Handle Seal Rebuild Kit 296895 (purchase separately). |
| 2 | 295678 | Cylinder end cap assembly | 1 | |
| 3 | 295676 | Spring | 1 | * Parts included in Trigger valve rebuild kit 296897 (purchase separately). |
| 4 | 295675 | Air cylinder | 1 | |
| 5 | 295709 | Socket head cap screw, 8-32 x 3/4 in. | 2 | |
| 6 | 295680 | Two position stop | 1 | |
| 7† | 295681 | O-ring | 1 | |
| 8 | 295682 | Rod draw bar | 1 | |
| 9† | 295683 | O-ring | 1 | |
| 10 | 295663 | Cylinder front stop | 1 | |
| 11† | 514279 | O-ring | 1 | |
| 12 | 295664 | Air piston assembly | 1 | |
| 13 | 295665 | Pipe nipple | 1 | |
| 14 | 295666 | Stop clamp screw | 1 | |
| 15† | 295667 | Nylon pellet | 1 | |
| 16 | 295673 | Gun block mount | 1 | |
| 17 | 295677 | Air needle valve | 1 | |
| 18 | 295668 | Spring | 1 | |
| 19 | 295669 | Socket head cap screw, 1/4-28 x 5/8 | 1 | |
| 20 | 295671 | Trigger mounting screw | 1 | |
| 21 | 295688 | Valve nut | 1 | |
| 23 | 295686 | Spool valve liner | 2 | |
| 24 | 295689 | Spring seat | 1 | |
| 26* | 296971 | Air valve spring | 1 | |
| 27†* | 106555 | O-ring, | 6 | |
| 28†* | C20988 | O-ring, fluoroelastomer | 3 | |
| 30 | 295438 | Locknut, elastic stop nut, 5-40 | 1 | |
| 32† | 295405 | Needle valve packing | 1 | |
| 33 | 295692 | Spray gun trigger | 1 | |
| 34 | 295684 | Socket head cap screw, 10-32 x 1/2 | 4 | |
| 35 | 295687 | Spool valve | 1 | |
| 36† | 295674 | Gasket | 1 | |
| 37† | 295706 | O-ring, Neoprene | 1 | |
| 38 | 295693 | Pipe plug, flush seal, 1/6 NPT | 1 | |
| 39 | 295662 | Pipe plug, flush seal, 1/8 NPT | 1 | |
| 40 | 103656 | Hex nipple, 1/8 NPT (optional) | 1 | |
| 41 | 295690 | Cylinder clamp | 1 | |
| 42 | C20003 | Socket head cap screw, 10-32 x 1/2 | 1 | |
| 43† | 295685 | O-ring | 2 | |

GX-7 DI Model Handle Assembly (295809)

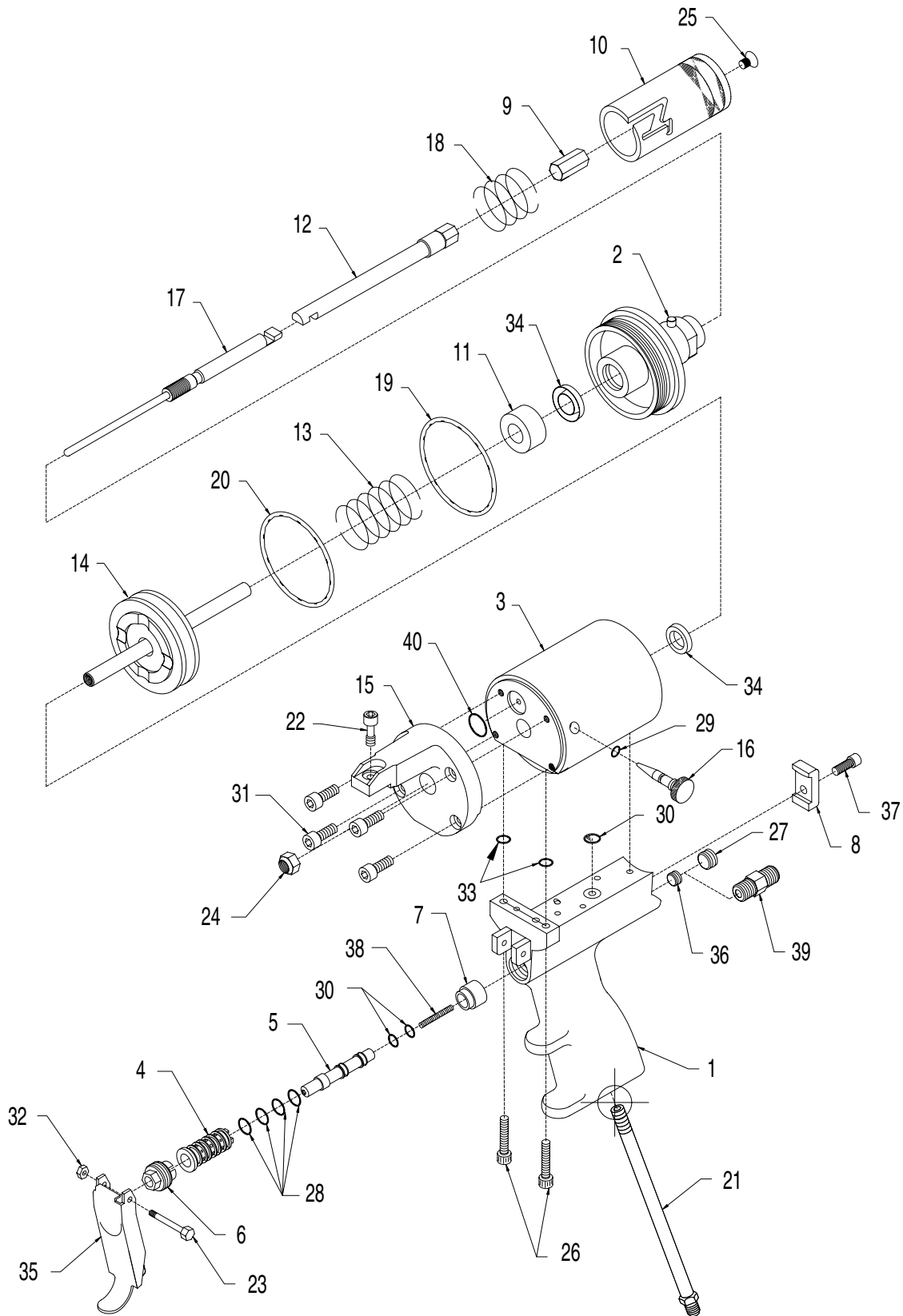

GX-7 DI Model Handle Assembly (295809)

| Ref. No. | Part No. | Description | Qty. |
|----------|----------|---|------|
| | | * Parts included in Trigger Valve Rebuild Kit 296897 (purchase separately). | |
| 1 | 296862 | Gun handle | 1 |
| 2 | 295714 | Cylinder end cap assembly | 1 |
| 3 | 295715 | Air cylinder | 1 |
| 4 | 295686 | Valve liner | 1 |
| 5 | 295687 | Valve spool | 1 |
| 6 | 295688 | Valve retainer nut | 1 |
| 7 | 295689 | Spring seat | 1 |
| 8 | 295690 | Cylinder clamp | 1 |
| 9 | 295716 | Stop, stroke, long | 1 |
| 10 | 295717 | Two position stop body | 1 |
| 11 | 295718 | Stroke spacer | 1 |
| 12 | 295719 | Valving rod holder | 1 |
| 13 | 295720 | Piston spring | 1 |
| 14 | 295712 | Piston assembly | 1 |
| 15 | 295721 | Gun block mount | 1 |
| 16 | 295713 | Air needle valve | 1 |
| 17 | 296863 | Valving rod, 125 SS | 1 |
| 18 | 295676 | Spring | 1 |
| 19† | 295681 | O-ring | 1 |
| 20† | 295683 | O-ring | 1 |
| 21 | 295665 | Pipe nipple | 1 |
| 22 | 295669 | Socket head cap screw, 1/4-28 x 5/8 | 1 |
| 23 | 295671 | Trigger mounting screw | 1 |
| 24 | 295431 | Locknut | 1 |
| 25 | 295722 | Flat head cap screw, 10-32 x 1/4 in. | 1 |
| 26 | 295709 | Socket head cap screw, 8-32 x 3/4 in. | 2 |
| 27 | 295662 | Pipe plug, flush seal, 1/8 in. | 1 |
| 28* | 106555 | O-ring, fluoroelastomer | 4 |
| 29† | C20988 | O-ring, fluoroelastomer | 1 |
| 30†* | 103337 | O-ring, fluoroelastomer | 3 |
| 31 | 295684 | Socket head cap screw, 10-32 x 5/8 in. | 4 |
| 32 | 295438 | Stop nut, elastic | 1 |
| 33† | 295685 | O-ring | 2 |
| 34† | 295496 | U-cup | 2 |
| 35 | 295692 | Trigger | 1 |
| 36 | 295693 | Pipe plug, flush seal, 1/16 in. | 1 |
| 37 | C20003 | Socket head cap screw, 10-32 x 1/2 | 1 |
| 38* | 295442 | Spring | 1 |
| 39 | 103656 | Hex nipple (optional), 1/8 MPT | 1 |
| 40† | 103338 | O-ring, fluoroelastomer | 1 |
| | | † Parts included in Air Cylinder Rebuild Kit 296895 (purchase separately). | |

GX-7 400 Model Handle Assembly (295799)

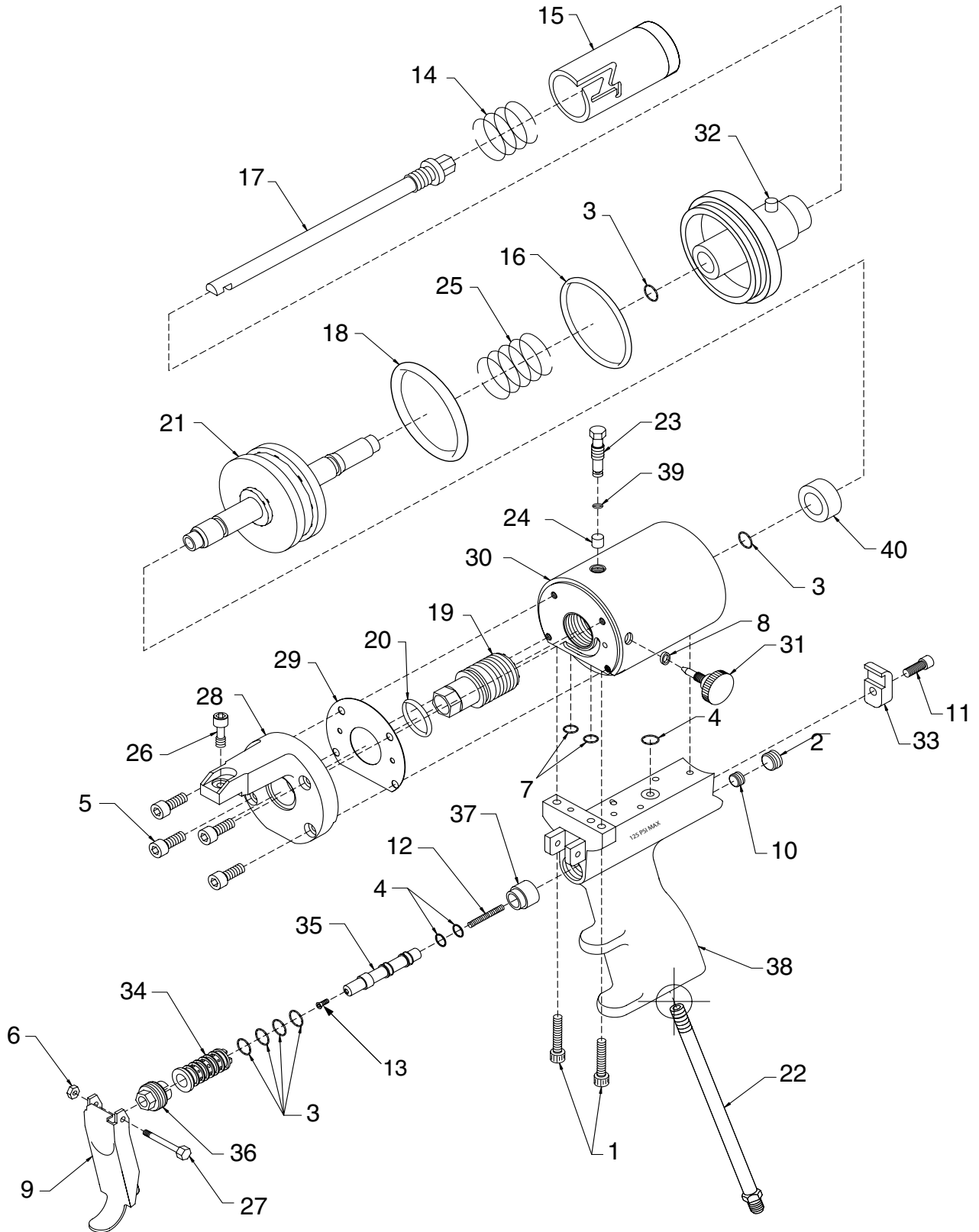

GX-7 400 Model Handle Assembly (295799)

| Ref. | No. | Part No. | Description | Qty. |
|------|-----|----------|------------------------------------|------|
| | 1 | 106245 | Cap screw, SCH | 2 |
| | 2 | 295662 | Pipe plug | 1 |
| | 3†* | 106555 | Packing o-ring | 6 |
| | 4†* | 103337 | Packing o-ring | 3 |
| | 5 | 295684 | Socket head cap screw | 4 |
| | 6 | 295438 | Stop nut, elastic, 5-40 | 1 |
| | 7†* | 295685 | O-ring | 2 |
| | 8† | 295405 | Needle valve, packing | 1 |
| | 9 | 295692 | Spray gun trigger | 1 |
| | 10 | 295693 | Pipe plug | 1 |
| | 11 | C20003 | Socket head cap screw | 1 |
| | 12* | 295442 | Spring | 1 |
| | 13 | 295695 | Button head cap screw | 1 |
| | 14 | 295676 | Spring | 1 |
| | 15 | 295771 | Two-position stop | 1 |
| | 16† | 295681 | O-ring | 1 |
| | 17 | 295682 | Draw rod bar | 1 |
| | 18† | 295683 | O-ring | 1 |
| | 19 | 295663 | Front cylinder stop | 1 |
| | 20† | 514279 | O-ring | 1 |
| | 21 | 295664 | Air piston | 1 |
| | 22 | 295665 | Pipe nipple fitting | 1 |
| | 23 | 295666 | Stop clamp screw | 1 |
| | 24† | 295667 | Pellet | 1 |
| | 25 | 295668 | Spring | 1 |
| | 26 | 295669 | Socket head cap screw, modified | 1 |
| | 27 | 295671 | Trigger mounting screw | 1 |
| | 28 | 295673 | Gun block base | 1 |
| | 29† | 295674 | Gasket | 1 |
| | 30 | 295675 | Air cylinder | 1 |
| | 31 | 295677 | Air needle valve | 1 |
| | 32 | 295678 | Cylinder end cap | 1 |
| | 33 | 295690 | Cylinder clamp | 1 |
| | 34 | 295686 | Valve liner | 1 |
| | 35 | 295687 | Valve spool | 1 |
| | 36 | 295688 | Retainer valve nut | 1 |
| | 37 | 295689 | Spring seat | 1 |
| | 38 | 296862 | Gun handle | 1 |
| | 39† | 295706 | O-ring | 1 |
| | 40 | 295708 | Spacer | 1 |

† Parts included in Air Cylinder Rebuild Kit
296895 (purchase separately).

* Parts included in Trigger Valve Rebuild Kit
296897 (purchase separately).

Coupling Block Assembly (295383)

All models

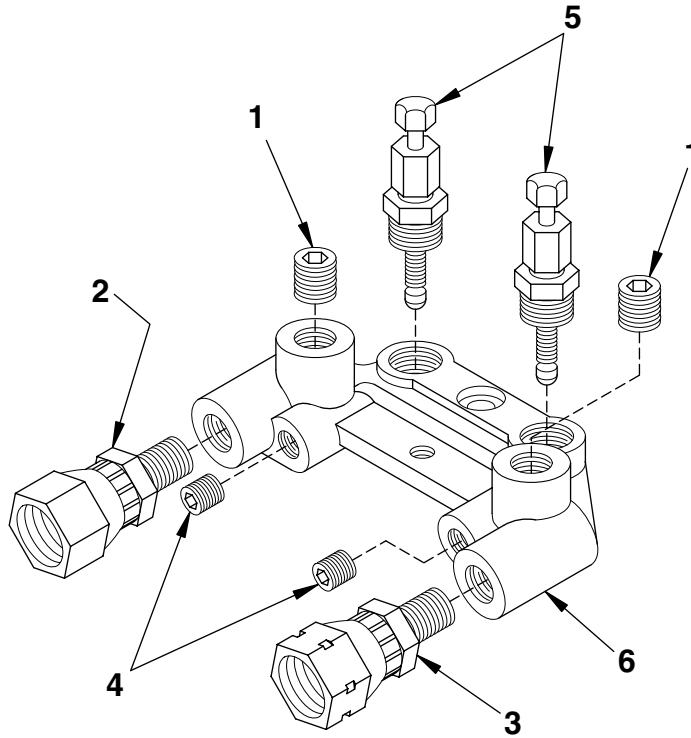

| Ref. No. | Part No. | Description | Qty |
|----------|----------|---------------------------------|-----|
| 1 | 295662 | Pipe plug, flush seal, 1/8 in. | 2 |
| 2 | 117634 | R-swivel fitting | 1 |
| 3 | 117635 | A-swivel fitting | 1 |
| 4 | 295693 | Pipe plug, flush seal, 1/16 in. | 2 |
| 5 | 296970 | Manual valve assembly | 2 |
| 6 | 296215 | Coupling block | 1 |

Specifications

GX-7A Mix Module Kit

| Module Kit†* | | Cleanout Tool | | | |
|--------------|------------|-----------------------|------------------|-------------------------|------------------|
| Part No. | Size Ref. | (A) Iso Port Part No. | Diameter in/(mm) | (R) Resin Port Part No. | Diameter in/(mm) |
| 296909 | #1 Round | 296262 | .0320 (.81) | 296262 | .032 (.81) |
| 296916 | #2 Round | 296253 | .018 (.45) | 296253 | .018 (.45) |
| 296919 | #3 Round | 296256 | .0225 (.57) | 296253 | .018 (.45) |
| 296921 | #4 Round | 296264 | .035 (.89) | 296262 | .032 (.81) |
| 296923 | #5 Round | 296256 | .0225 (.57) | 296260 | .028 (.71) |
| 296925 | #7 Flat | 296260 | .028 (.71) | 296260 | .028 (.71) |
| 296906 | #10 Flat | 296283 | .036 (.91) | 296283 | .036 (.91) |
| 296910 | #12 Flat | 296255 | .021 (.53) | 296255 | .021 (.53) |
| 296915 | #16 Round | 296260 | .028 (.71) | 296260 | .028 (.71) |
| 296917 | #22 Round | 296256 | .0225 (.57) | 296256 | .0225 (.57) |
| 296924 | #53 Round | 296257 | .024 (.61) | 296255 | .021 (.53) |
| 296926 | MA Round | 296265 | .037 (.94) | 296265 | .037 (.94) |
| 296875 | A2 Pour | 296253 | .018 (.45) | 296253 | .018 (.45) |
| 296876 | A3 Pour | 296267 | .039 (.99) | 296267 | .039 (.99) |
| 296868 | A5 Pour | 296262 | .032 (.81) | 296262 | .032 (.81) |
| 296870 | A5-FS Pour | 296262 | .032 (.81) | 296262 | .032 (.81) |



Each module has a specially sized cleanout tool. To avoid damage to module, use correct cleanout tool.

† Module Kits include one mix module and both cleanout tools. See following table.

* Some Module Kits also available in packs. See following table.

| Mix Module Kit | | |
|----------------|------------|--------------------|
| Part No. | Size Ref. | Qty./Pack |
| 296908 | #1 Round | 12 (with 2 drills) |
| 296869 | A5 Pour | 12 |
| 296871 | A5-FS Pour | 12 |
| 296872 | A10 Pour | 12 |
| 296873 | A20 Pour | 12 |
| 296874 | A2 Pour | 12 (with 2 drills) |
| 296911 | STD Blank | 5 |
| 296912 | STD Blank | 100 |
| 296913 | PEEK Blank | 5 |

Set-Up Chart for GX-7A Model

| Pressure (psi) | Output (lbs/min) | Pattern Dia. (inches) | Module Part No. | Polyol Port Size | No. Orifices | Iso Port Size | No. Orifices | Tip |
|----------------------------|------------------|-----------------------|-----------------|------------------|--------------|---------------|--------------|--------|
| Round Spray Pattern | | | | | | | | |
| 1000 | 22 | *22 | 296909 (#1) | .0320 | 4 | .0320 | 4 | 296712 |
| 1000 | 12 | *12 | 296919 (#3) | .0180 | 4 | .0225 | 4 | 296710 |
| 1600 | 16 | *14 | 296923 (#5) | .0280 | 4 | .0225 | 4 | 296710 |
| 2000 | 30 | *24 | 296909 (#1) | .0320 | 4 | .0320 | 4 | 296694 |
| 3000 | 40 | *24 | 296921 (#4) | .0320 | 4 | .0350 | 4 | 296695 |
| Pour Pattern | | | | | | | | |
| 600 | 3.5 | N/A | 296875 (A2) | .0180 | 1 | .0180 | 1 | 296697 |
| 600 | 12 | N/A | 296876 (A3) | .0390 | 1 | .0390 | 1 | 296697 |
| Fan Spray Pattern | | | | | | | | |
| 1000 | 12 | ❖16 x 4 | 296925 (#7) | .0280 | 2 | .0280 | 2 | 296704 |
| 1500 | 24 | ❖22 x 4 | 296312 (#10) | .0360 | 2 | .0360 | 2 | 296703 |
| 1500 | 5 | ❖16 x 3 | 296910 (#12) | .0210 | 2 | .0210 | 2 | 296705 |

* At 24 in. above substrate

❖ At 18 in. above substrate

GX-7 400 Mix Module Kit

| Module Kits | | | Cleanout Drill | | | |
|------------------|-----------|----------|-------------------|------------------|----------------------|------------------|
| Part No. | Size Ref. | Quantity | Iso Port Part No. | Diameter in/(mm) | Polyol Port Part No. | Diameter in/(mm) |
| 296885 296884 | 402 Round | 1 12 | 296253 | .018 (.45) | 296253 | .018 (.45) |
| 296859 296860 | 451 Fan | 1 12 | 296253 | .018 (.45) | 296253 | .018 (.45) |
| 296888 296887 | 452 Fan | 1 12 | 296254 | .020 (.51) | 296254 | .020 (.51) |
| 296891 296890 | 453 Fan | 1 12 | 296258 | .025 (.64) | 296256 | .0225 (.57) |

| |
|--|
| CAUTION |
| Each module kit includes cleanout drills. To avoid damage to module, use correct cleanout drill. |

Set-up Chart for GX-7 400 Model

| Pressure (psi) | Output (lbs/min) | Pattern Dia. (inches) | Module Part No. | Polyol Port Size | No. Orifices | Iso Port Size | No. Orifices | Tip |
|----------------------------|------------------|-----------------------|-----------------|------------------|--------------|---------------|--------------|--------|
| Round Spray Pattern | | | | | | | | |
| 1500 | 3.5 | ✖8 | 296885 (402) | .0180 | 1 | .0180 | 1 | 296858 |
| Fan Spray Pattern | | | | | | | | |
| 1500 | 3.5 | ❖16 x 3 | 296859 (451) | .0180 | 1 | .0180 | 1 | 296853 |
| 1500 | 4.5 | ❖16 x 3 | 296888 (452) | .0200 | 1 | .0200 | 1 | 296853 |
| 1500 | 8.0 | ❖16 x 3 | 296891 (453) | .0250 | 2 | .0225 | 2 | 296855 |

✖ At 24 in. above substrate

❖ At 18 in. above substrate

| Tip Kits (for GX-7 400 Gun) | | |
|------------------------------------|----------|----------|
| Part No. | No. Ref. | Quantity |
| 296858 | 40 Round | 1 |
| 296852 | 210 Fan | 1 |
| 296853 | 212 Fan | 1 |
| 296854 | 212 Fan | 5 |
| 296855 | 213 Fan | 1 |
| 296856 | 213 Fan | 5 |
| 296857 | 214 Fan | 1 |
| 296892 | TOM | 1 |

GX-7 DI Model Specifications

| Module/Tip Data for Chemical Sprayed at 2500 PSI | | | | |
|--|---------------------------|----------|-----------------|-------------------|
| ✖Module Kit | Cleanout Drill | Ref. No. | ✖Pattern | ✖Output (lbs/min) |
| Fan Spray Pattern | | | | |
| 296900 (#2) | 296282 (.086 diameter) | 212 | 12 in. wide | 12 |
| | | 206 | 20 in. wide | 22 |
| | | 213 | 12 in. wide | 12 |
| | | 204 | 20 in. wide | 21 |
| 296901 (#4) | 296260 (.028 diameter) | 212 | 10 in. wide | 8 |
| | | 206 | 24 in. wide | 11 |
| | | 204 | 18 in. wide | 10 |
| 296903 (#5) | 296253 (.018 diameter) | 212 | 11 in. wide | 4 |
| | | 213 | 12 in. wide | 4 |
| | | 208 | 8 in. wide | 4 |
| Round Spray Pattern | | | | |
| 296903 (#5) | 296253 (.018 diameter) | 40 | 4 in. diameter | 8 |
| | | 55 | 7 in. diameter | 9.5 |
| | | 70 | 8 in. diameter | 9.75 |
| | | 90 | 10 in. diameter | 9.75 |

✖ Actual results may vary due to chemical system characteristics, temperature, pressure, and ratio.

✖ Includes appropriate cleanout drills.

| Mix Module Kit | | |
|----------------|--------------|----------|
| Part No. | Size Ref. | Quantity |
| 296898 | PEEK 018/018 | 1 |
| 296899 | PEEK 028/028 | 1 |

Tip Kits

For GX-7A and GX-7 DI Models

| Round Tip Kits | | |
|----------------|------|----------|
| Part No. | Size | Quantity |
| 296708 | 40 | 1 |
| 296709 | 46 | 1 |
| 296717 | 55 | 5 |
| 296710 | 70 | 1 |
| 296718 | 70 | 5 |
| 296711 | 80 | 1 |
| 296719 | 80 | 5 |
| 296712 | 90 | 1 |
| 296720 | 90 | 5 |
| 296694 | 100 | 1 |
| 296714 | 100 | 5 |
| 296695 | 110 | 1 |
| 296696 | 110 | 5 |
| 296697 | 125 | 1 |
| 296877 | 140 | 1 |

| Flat Tip Kits | | |
|---------------|---------------|------|
| Part No. | No. Ref. | Qty. |
| 296698 | 202 | 1 |
| 296699 | 203 | 1 |
| 296700 | 204 | 1 |
| 296701 | 206 | 1 |
| 296702 | 208 | 1 |
| 296703 | 209 | 1 |
| 296704 | 210 | 1 |
| 296715 | 210 | 5 |
| 296882 | 212.5 SPEC | 1 |
| 296705 | 212 | 1 |
| 296716 | 212 | 5 |
| 296706 | 213 | 1 |
| 296883 | 213- SPEC | 1 |
| 296707 | 215 | 1 |

Tool Kits

GX-7A and GX-7 DI models: 296835

GX-7 400 model: 296184

Technical Data

| Category | Data |
|----------------------------|--|
| Air Supply | 100-125 psi (7.9 bars) |
| Maximum Operating Pressure | 3500 psi (24 MPa, 240 bar) |
| Maximum Output * | GX-7A Model: 40 lbs/min (18 kg/min) |
| | GX-7 DI Model: 22 lbs/min (10 kg/min) |
| | GX-7 400 Model: 8 lbs/min (3.6 kg/min) |
| Minimum Output * | GX-7A Model: 4 lbs/min (1.8 kg/min) |
| | GX-7 DI Model: 4 lbs/min (1.8 kg/min) |
| | GX-7 400 Model: 3.5 lbs/min (1.6 kg/min) |
| Height | 9 in. (23 cm) |
| Length | 9.5 in. (24 cm) |
| Width | 4.5 in. (11 cm) |
| Weight | 3.5 lbs. (1.5 kg) |
| Mixing | GX-7A Model: Internal impingement, airless atomization, solvent-free, mechanically self cleaning |
| | GX-7 DI Model: Internal direct impingement, airless atomiza- tion, solvent-free, mechanically self cleaning |
| | GX-7 400 Model: Internal direct impingement, airless atomiza- tion, solvent-free, mechanically self cleaning |

* *Theoretical: actual results will vary with operating conditions*

Graco Standard Warranty

Graco warrants all equipment referenced in this document which is manufactured by Graco and bearing its name to be free from defects in material and workmanship on the date of sale to the original purchaser for use. With the exception of any special, extended, or limited warranty published by Graco, Graco will, for a period of twelve months from the date of sale, repair or replace any part of the equipment determined by Graco to be defective. This warranty applies only when the equipment is installed, operated and maintained in accordance with Graco's written recommendations.

This warranty does not cover, and Graco shall not be liable for general wear and tear, or any malfunction, damage or wear caused by faulty installation, misapplication, abrasion, corrosion, inadequate or improper maintenance, negligence, accident, tampering, or substitution of non-Graco component parts. Nor shall Graco be liable for malfunction, damage or wear caused by the incompatibility of Graco equipment with structures, accessories, equipment or materials not supplied by Graco, or the improper design, manufacture, installation, operation or maintenance of structures, accessories, equipment or materials not supplied by Graco.

This warranty is conditioned upon the prepaid return of the equipment claimed to be defective to an authorized Graco distributor for verification of the claimed defect. If the claimed defect is verified, Graco will repair or replace free of charge any defective parts. The equipment will be returned to the original purchaser transportation prepaid. If inspection of the equipment does not disclose any defect in material or workmanship, repairs will be made at a reasonable charge, which charges may include the costs of parts, labor, and transportation.

THIS WARRANTY IS EXCLUSIVE, AND IS IN LIEU OF ANY OTHER WARRANTIES, EXPRESS OR IMPLIED, INCLUDING BUT NOT LIMITED TO WARRANTY OF MERCHANTABILITY OR WARRANTY OF FITNESS FOR A PARTICULAR PURPOSE.

Graco's sole obligation and buyer's sole remedy for any breach of warranty shall be as set forth above. The buyer agrees that no other remedy (including, but not limited to, incidental or consequential damages for lost profits, lost sales, injury to person or property, or any other incidental or consequential loss) shall be available. Any action for breach of warranty must be brought within two (2) years of the date of sale.

GRACO MAKES NO WARRANTY, AND DISCLAIMS ALL IMPLIED WARRANTIES OF MERCHANTABILITY AND FITNESS FOR A PARTICULAR PURPOSE, IN CONNECTION WITH ACCESSORIES, EQUIPMENT, MATERIALS OR COMPONENTS SOLD BUT NOT MANUFACTURED BY GRACO. These items sold, but not manufactured by Graco (such as electric motors, switches, hose, etc.), are subject to the warranty, if any, of their manufacturer. Graco will provide purchaser with reasonable assistance in making any claim for breach of these warranties.

In no event will Graco be liable for indirect, incidental, special or consequential damages resulting from Graco supplying equipment hereunder, or the furnishing, performance, or use of any products or other goods sold hereto, whether due to a breach of contract, breach of warranty, the negligence of Graco, or otherwise.

FOR GRACO CANADA CUSTOMERS

The Parties acknowledge that they have required that the present document, as well as all documents, notices and legal proceedings entered into, given or instituted pursuant hereto or relating directly or indirectly hereto, be drawn up in English. Les parties reconnaissent avoir convenu que la rédaction du présente document sera en Anglais, ainsi que tous documents, avis et procédures judiciaires exécutés, donnés ou intentés, à la suite de ou en rapport, directement ou indirectement, avec les procédures concernées.

Graco Information

TO PLACE AN ORDER, contact your Graco distributor or call to identify the nearest distributor.

Phone: 612-623-6921 **or Toll Free:** 1-800-328-0211 **Fax:** 612-378-3505

All written and visual data contained in this document reflects the latest product information available at the time of publication. Graco reserves the right to make changes at any time without notice.

This manual contains English. MM 311321

Graco Headquarters: Minneapolis

International Offices: Belgium, China, Japan, Korea

GRACO INC. P.O. BOX 1441 MINNEAPOLIS, MN 55440-1441

Copyright 2005, Graco Inc. is registered to I.S. EN ISO 9001

www.graco.com

Revised 07/2008