

Reactor A-20

311512E

For spraying or dispensing 1:1 mix ratio materials, including epoxies, and polyurethane foam. Not for use in explosive atmospheres.

253831 Air operated, electrically heated, plural component proportioner.

This model is field-configurable to the following supply voltages:

230 V, 1 Phase

230 V, 3 Phase

380 V, 3 Phase

2,000 psi (14 MPa, 140 bar) Maximum Fluid Working Pressure

120 psi (0.84 MPa, 8.4 bar) Maximum Air Working Pressure



Important Safety Instructions

Read all warnings and instructions in this manual.
Save these instructions.

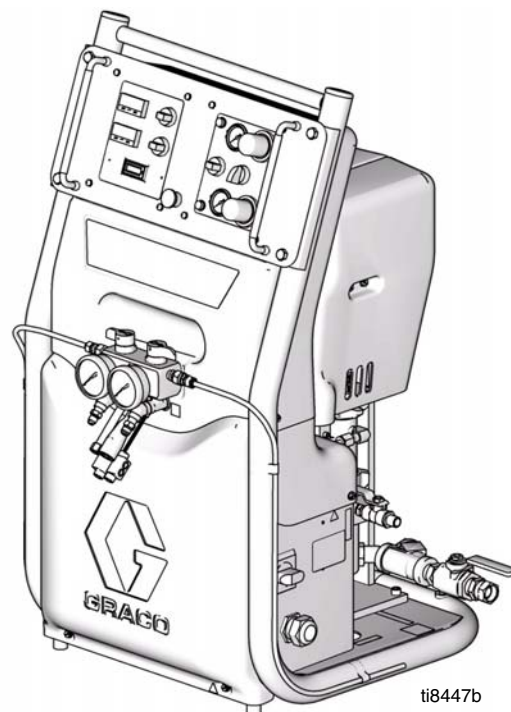

ti8447b

CE



9902471
Conforms to ANSI/UL
Std. 499 Certified to
CAN/CSA Std.
C22.2 No. 88

Contents

Supplied Manuals	3	Graco Standard Warranty	48
Related Manuals	3	Graco Information	48
Warnings	4		
Isocyanate Hazard	6		
Moisture Sensitivity of Isocyanates	6		
Keep Components A and B Separate	6		
Changing Materials	6		
Before Beginning Repair	7		
Pressure Relief Procedure	7		
Flushing	7		
Troubleshooting	8		
Repair	12		
Shroud Removal	12		
Pump Removal	12		
Pump Installation	14		
Recirculation / Over Pressure Relief Block	15		
Air Motor	15		
Reversing Switch	16		
Solenoid Valve Replacement	16		
Air Inlet Filter / Water Separator (Auto Drain) . .	16		
Primary Heater	17		
Heating Elements	18		
Fluid Inlet Filter Screen	19		
Isocyanate Pump Lubricant	19		
Fluid Temperature Sensor (FTS)	20		
Replacing Control Components	22		
Hose Power Controller / Circuit Breaker / Relays	22		
Air Motor Up / Down / Pressure Regulators / Gauges	23		
Control Panel Wiring	23		
Accessories	24		
Recommended Spare Parts	25		
Parts	26		
Reactor A-20	26		
Electrical Control Panel	28		
Relief Manifold	30		
Air Inlet	30		
A-20 Air Motor Pump Assembly	32		
Primary 6000W Heater	34		
Air Tubing Connections	36		
Reactor A-20 Wiring Schematic	38		
Wiring Diagrams	43		
Heater Circuit	43		
Pump Circuit	44		
Hose Circuit	45		
Technical Data	47		

Supplied Manuals

The following manuals are shipped with the Reactor™ A-20 Proportioner. Refer to these manuals for detailed equipment information.

Order Part No. 15M334 for a compact disk of Reactor manuals translated in several languages.

Manuals are also available at www.graco.com.

Reactor A-20 Proportioner	
Part No.	Description
311511	Reactor A-20 Proportioner, Operation Manual (English)
Proportioning Pump	
Part No.	Description
309577	Proportioning Pump Repair-Parts Manual (English)

Related Manuals

The following manuals are for accessories used with the Reactor™.

Order Part No. 15M334 for a compact disk of Reactor manuals translated in several languages.





Order Part No. 15B381 for a compact disk of Fusion manual translated in several languages.







Circulation and Return Tube Kit	
Part No.	Description
309852	Instruction-Parts Manual (English)
Heated Hose	
Part No.	Description
309572	Instruction-Parts Manual (English)
Fusion Air Purge Spray Gun	
Part No.	Description
309550	Instruction-Parts Manual (English)
Fusion Mechanical Purge Spray Gun	
Part No.	Description
309856	Instruction-Parts Manual (English)
Circulation Hose Manifold Kit	
Part No.	Description
309818	Instruction-Parts Manual (English)

Feed Pump Kit	
Part No.	Description
309815	Instruction-Parts Manual (English)
Air Supply Kit	
Part No.	Description
309827	Instruction-Parts Manual (English) for Feed Pump Air Supply Kit

Warnings

The following general warnings are for the setup, use, grounding, maintenance, and repair of this equipment. Additional, more specific warnings may be found throughout the body of this manual where applicable. *Symbols appearing in the body of the manual refer to these general warnings. When these symbols appear throughout the manual, refer back to these pages for a description of the specific hazard.*

 WARNING	
	<p>ELECTRIC SHOCK HAZARD</p> <p>Improper grounding, setup, or usage of the system can cause electric shock.</p> <ul style="list-style-type: none"> • Turn off and disconnect power cord before servicing equipment. • Use only grounded electrical outlets. • Use only 3-wire extension cords. • Ensure ground prongs are intact on sprayer and extension cords. • Do not expose to rain. Store indoors.
	<p>TOXIC FLUID OR FUMES HAZARD</p> <p>Toxic fluids or fumes can cause serious injury or death if splashed in the eyes or on skin, inhaled, or swallowed.</p> <ul style="list-style-type: none"> • Read MSDS's to know the specific hazards of the fluids you are using. • Store hazardous fluid in approved containers, and dispose of it according to applicable guidelines. • Always wear impervious gloves when spraying or cleaning equipment.
	<p>PERSONAL PROTECTIVE EQUIPMENT</p> <p>You must wear appropriate protective equipment when operating, servicing, or when in the operating area of the equipment to help protect you from serious injury, including eye injury, inhalation of toxic fumes, burns, and hearing loss. This equipment includes but is not limited to:</p> <ul style="list-style-type: none"> • Protective eyewear • Clothing and respirator as recommended by the fluid and solvent manufacturer • Gloves • Hearing protection
	<p>SKIN INJECTION HAZARD</p> <p>High-pressure fluid from gun, hose leaks, or ruptured components will pierce skin. This may look like just a cut, but it is a serious injury that can result in amputation. Get immediate surgical treatment.</p> <ul style="list-style-type: none"> • Do not point gun at anyone or at any part of the body. • Do not put your hand over the spray tip. • Do not stop or deflect leaks with your hand, body, glove, or rag. • Do not spray without tip guard and trigger guard installed. • Engage trigger lock when not spraying. • Follow Pressure Relief Procedure in this manual, when you stop spraying and before cleaning, checking, or servicing equipment.

 WARNING	
	<p>FIRE AND EXPLOSION HAZARD</p> <p>Flammable fumes, such as solvent and paint fumes, in work area can ignite or explode. To help prevent fire and explosion:</p> <ul style="list-style-type: none"> • Use equipment only in well ventilated area. • Eliminate all ignition sources; such as pilot lights, cigarettes, portable electric lamps, and plastic drop cloths (potential static arc). • Keep work area free of debris, including solvent, rags and gasoline. • Do not plug or unplug power cords, or turn power or light switches on or off when flammable fumes are present. • Ground all equipment in the work area. See Grounding instructions. • Use only grounded hoses. • Hold gun firmly to side of grounded pail when triggering into pail. • If there is static sparking or you feel a shock, stop operation immediately. Do not use equipment until you identify and correct the problem. • Keep a working fire extinguisher in the work area.
	<p>PRESSURIZED ALUMINUM PARTS HAZARD</p> <p>Do not use 1,1,1-trichloroethane, methylene chloride, other halogenated hydrocarbon solvents or fluids containing such solvents in pressurized aluminum equipment. Such use can cause serious chemical reaction and equipment rupture, and result in death, serious injury, and property damage.</p>
	<p>EQUIPMENT MISUSE HAZARD</p> <p>Misuse can cause death or serious injury.</p> <ul style="list-style-type: none"> • This equipment is for professional use only. • Do not leave the work area while equipment is energized or under pressure. Turn off all equipment and follow the Pressure Relief Procedure in this manual when equipment is not in use. • Do not operate the unit when fatigued or under the influence of drugs or alcohol. • Do not exceed the maximum working pressure or temperature rating of the lowest rated system component. See Technical Data in all equipment manuals. • Use fluids and solvents that are compatible with equipment wetted parts. See Technical Data in all equipment manuals. Read fluid and solvent manufacturer's warnings. For complete information about your material, request MSDS forms from distributor or retailer. • Check equipment daily. Repair or replace worn or damaged parts immediately with genuine manufacturer's replacement parts only. • Do not alter or modify equipment. • Use equipment only for its intended purpose. Call your distributor for information. • Route hoses and cables away from traffic areas, sharp edges, moving parts, and hot surfaces. • Do not kink or over bend hoses or use hoses to pull equipment. • Keep children and animals away from work area. • Comply with all applicable safety regulations.
	<p>MOVING PARTS HAZARD</p> <p>Moving parts can pinch or amputate fingers and other body parts.</p> <ul style="list-style-type: none"> • Keep clear of moving parts. • Do not operate equipment with protective guards or covers removed. • Pressurized equipment can start without warning. Before checking, moving, or servicing equipment, follow the Pressure Relief Procedure in this manual. Disconnect power or air supply.
	<p>BURN HAZARD</p> <p>Equipment surfaces and fluid that's heated can become very hot during operation. To avoid severe burns, do not touch hot fluid or equipment. Wait until equipment/fluid has cooled completely.</p>

Isocyanate Hazard



Spraying materials containing isocyanates creates potentially harmful mists, vapors, and atomized particulates.

Read material manufacturer's warnings and material MSDS to know specific hazards and precautions related to isocyanates.

Prevent inhalation of isocyanate mists, vapors, and atomized particulates by providing sufficient ventilation in the work area. If sufficient ventilation is not available, a supplied-air respirator is required for everyone in the work area.

To prevent contact with isocyanates, appropriate personal protective equipment, including chemically impermeable gloves, boots, aprons, and goggles, is also required for everyone in the work area.

Moisture Sensitivity of Isocyanates

Isocyanates (ISO) are catalysts used in two component foam and polyurea coatings. ISO will react with moisture (such as humidity) to form small, hard, abrasive crystals, which become suspended in the fluid. Eventually a film will form on the surface and the ISO will begin to gel, increasing in viscosity. If used, this partially cured ISO will reduce performance and the life of all wetted parts.

 The amount of film formation and rate of crystallization varies depending on the blend of ISO, the humidity, and the temperature.

To prevent exposing ISO to moisture:

- Always use a sealed container with a desiccant dryer in the vent, or a nitrogen atmosphere. **Never** store ISO in an open container.

- Keep the felt washers in the pump wet-cups saturated with Graco ISO pump oil, Part No. 217374. The lubricant creates a barrier between the ISO and the atmosphere.
- Use moisture-proof hoses specifically designed for ISO, such as those supplied with your system; see **Accessories**, page 24.
- Never use reclaimed solvents, which may contain moisture. Always keep solvent containers closed when not in use.
- Never use solvent on one side if it has been contaminated from the other side.
- Always park pumps when you shutdown.
- Always lubricate threaded parts with Part No. 217374 ISO pump oil or grease when reassembling.

Keep Components A and B Separate



CAUTION

To prevent cross-contamination of the equipment's wetted parts, **never** interchange component A (isocyanate) and component B (resin) parts.

Changing Materials

- When changing materials, flush the equipment multiple times to ensure it is thoroughly clean.
- Always clean the fluid inlet strainers after flushing; see **Fluid Inlet Filter Screen**, page 19.
- Check with your material manufacturer for chemical compatibility.
- Most materials use ISO on the A side, but some use ISO on the B side.
- Epoxies often have amines on the B (hardener) side. Polyureas often have amines on the B (resin) side.

Before Beginning Repair

						
<p>Repairing this equipment requires access to parts that may cause electric shock or other serious injury if work is not performed properly. Electrical troubleshooting must be done by a qualified electrician. Be sure to shut off all power to equipment and lock out power at the source before repairing.</p>						

Pressure Relief Procedure

						
---	---	--	--	--	--	--

1. Turn off feed pumps and agitator if used.
2. Turn PARK/RUN switch to PARK.
3. Trigger gun to relieve pressure.
4. Turn off air inlet valve.
5. Engage gun piston safety lock.



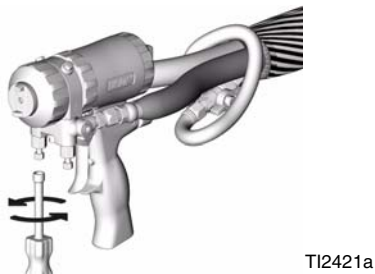

6. Verify gun fluid manifold valves A and B are closed.







7. Close pump inlet supply valves.

Flushing

						
<p>Flush equipment only in a well-ventilated area. Do not spray flammable fluids. Do not turn on heaters while flushing with flammable solvents.</p>						

- Flush with a compatible solvent.
- Use lowest possible pressure when flushing.
- To flush entire system, circulate through gun fluid manifold (with gun removed from manifold).
- Always leave hydraulic oil or a non-water based, non-water absorbent fluid in system. Do not use water.

						
<p>Only use flush solvents that are compatible with Fluoroelastomer seals. Non-compatible solvents will damage seals and cause hazardous conditions, such as high pressure leaks and pressure switch failure.</p>						

Troubleshooting

Power

PROBLEM	CAUSE	SOLUTION
Reactor does not operate	No power	Plug in power cord Turn Main Disconnect Switch ON
	Power cord not connected properly	Check connections
No power when disconnect switch is turned on; using 230V, 1 phase or 230V, 3 phase power	Power terminal jumper still at 380V, 3 phase position, as shipped from factory	Place jumpers in correct position; see operation manual 311511 and label inside front lower cabinet.
External main supply power circuit breaker trips and Reactor disconnect switch fails when switch is turned on.	Power terminal jumper was left in 230V, 1 phase position. When using 230V, 3 phase or 380V, 3 phase power	Place jumpers in correct position; see manual 311511. Replace main power disconnect switch; see page 26.
No temperature display lights at startup	No power	Plug in power cord Turn Main Disconnect Switch ON
	Control power fuses blown	Check and replace fuses on long terminal strip
Reactor stops working; all lights are off except temperature displays	Red stop switch was pushed	Reset all control switches to START

Pumps and Pressures

PROBLEM	CAUSE	SOLUTION
Pump does not run up and down but green switch light is on	PARK/RUN switch in PARK position	Turn PARK/RUN switch to RUN
	No air supply	Air supply line not connected Open inlet air ball valve
	Air pressure regulators set at 0 psi	Turn up air pressure regulators
Pump runs but no fluid pressure	Fluid inlet ball valves closed	Open fluid ball valves
Fluid pressure low or dropping	Air supply pressure low when spraying	Increase inlet air pressure
		Increase air compressor size to meet flow requirements
		Remove airline quick disconnects Use 3/8 in. (0.95 cm) ID or larger air supply hose
	Icing in air motor quick exhausts or mufflers	Check and repair fan Check inlet filter water separator; see page ##. Stop spraying for 5 minutes while fan melts ice.
Pump output low	Obstructed gun impingement ports or filters	Flush and clean gun; see gun manual
One pressure gauge drops when pumps are stalled on both the upstroke and the downstroke	Leaking pump throat	Repair pump; see 309577
	Leak between pump and gun	Check fluid tubes, heater, and hoses
	Spray gun is leaking on one side	Clean and repair spray gun
One pressure gauge drops when pumps are stalled on the downstroke, but not the upstroke	Inlet ball check not sealing	Clean or replace; see 309577
	Inlet check seat o-ring not sealing	Repair pump; see 309577

PROBLEM	CAUSE	SOLUTION
One pressure gauge drops when pumps are stalled on the upstroke, but not the downstroke	Piston check ball not sealing	Repair pump; see 309577
	Piston packing not sealing	Repair pump; see 309577
	Loose piston stud in pump	Repair pump; see 309577
	Bad inside sleeve seal	Repair o-ring; see 309577
A side rich; lack of B side	A side gauge is low	B side restriction downstream of gauge. Check gun check valve screen, mix module, or mix manifold restrictor.
	B side gauge is low	B side material supply problem. Check B side inlet strainer and pump intake valve.
B side rich; lack of A side	A side gauge is low	A side material supply problem. Check A side inlet strainer and pump intake valve.
	B side gauge is low	A side restriction downstream of gauge. Check gun check valve screen, mix module, or mix manifold restrictor.
Fluid pressures not balanced between A and B side	Fluid viscosities not equal	Sometimes normal if pressure offset is below 200 psi (14 bar) Preheat material in drums by recirculating; see Operation manual 311511
	Inlet Y-strainer screen plugged on low pressure side	Clean inlet filter screen
	Gun port or filter plugged on high pressure side	Clean or replace; see gun manual
	Pump inlet ball not seating or sticking	Clean seating; see pump manual
	Drum fluid outlet supply hose too small	Use 3/4 in. (1.9 cm) ID hose with short length
	Low side feed pump not working	Turn on or repair feed pump
Pump does not reverse direction	Obstruction of air motor or pumps	Check and clear obstruction
	Reversing switch failed	Check and service switch assembly; see page 16.
	Air solenoid valve failed.	Check solenoid valve, see page 16.
Unequal fluid pressure between UP/DOWN stroke	Air regulator pressures not set correctly. Feed pumps boost pressure on up stroke.	Adjust UP/DOWN air regulators to create equal fluid outlet pressures; see Operation manual 311511.
Pumps stop moving, Pump Mode Function green knob light off	Over-pressure shutdown from imbalanced pressures. Plugging one side will double the pressure. Starving one side will double the pressure on the other side.	Check for gun restriction, see Gun manual
		Air pressure set too high; lower air pressure
		Pump cavitating on low pressure side; check inlet and clean strainer. Check feed pump.
		Heater plugged on low pressure side; see Repair, page 18.

PROBLEM	CAUSE	SOLUTION
Air motor doesn't move with air pressure applied	Reversing switch failed	Inspect and repair parts; see page 32.
	Solenoid valve failed	Replace valve.
Pump movement speed is erratic	Worn air motor seals	Replace seals; see page see page 32.
	Worn pump seals	Replace seals; see Pump manual.
	Worn solenoid valve seals	Replace solenoid valve; see pages 16 and 32.

Hose Heat

PROBLEM	CAUSE	SOLUTION
Hose temperature controller display flashing "SbEr" and "H20.0"	FTS not connected. Control does not see thermocouple.	Check and connect FTS connector at each joint; see page 20.
Hose temperature controller display dropping with hose switch green light on	Hose power-lock connector loose	Connect hose power-lock at Reactor
		Check and reconnect all connector points along hose. Use wire tie to hold together.
Hose heat switch green light goes out	Hose over-temperature shutdown	Repair or replace hose power controllers. See page 22. Reset hose temperature control knob to START.
		Set Point 2 (SP2) deviation alarm set too low. Raise SP2 to 30 °F (17 °C) default setting.
Hose temperature display overshoots setpoint and/or green switch light goes out	Hose coiled up on itself too much, sends overheated fluid to FTS	Straighten out coiled hose
	Insulation peeled off of hose at FTS sensor inside hose causes the rest of hose to overheat.	Insulate hose up to FTS. FTS must represent bulk of heated hose.
Hose heat too low	Temperature setpoint too low	Check setpoint (SP1); adjust if necessary
	Pre-heaters too low	
	Fluid flow too high	Use smaller mix chamber. Decrease pressure.
	Hose heat not turned on long enough. More than 210 ft. connected.	Allow more time for hose heat to heat up or preheat supply drums
	Loose electrical connectors. Green light on Power Controller is off.	Check power and FTS connections; see page 20.
Either heat temperature controller display dark	Controller connector loose	Check and reconnect
No lights on hose power controller in lower cabinet while temperature controller 01 output light is on steady. Green switch light is on. No heat in hose.	No 4.5 to 12 Vdc signal between terminal #5(+) and #6(-)	Replace the temperature controller (143).
	Polarity is reversed on 4.5 to 12 Vdc	Reverse blue wires.
	No power to hose power controller terminals 2 and 3; 220-240 Vac	Make sure green light on hose switch is on. Make sure hose primary circuit breaker is on.

PROBLEM	CAUSE	SOLUTION
Hose power controller in lower cabinet illuminates green light, but amber light not on. Temperature controller 01 output light is on steady. No heat in hose.	Opening in hose circuit	Disconnect main hose plug. Check for only 0.4 - 6 ohm resistance through hose circuit. Make sure all hose connections are secure.
	Hose secondary circuit breaker open	Check hose secondary breaker. Check for continuity across breaker. Check current sensor for 18 ohms; see page 23.
Hose power controller in lower cabinet illuminates green light, but amber light not on when temperature controller 01 output light is on steady. High heat in hose. Causing temperature overshoot.	Current sensor doughnut not connected	Check hose power controller connections 15 and 16.
	Hose cable not running through current sensor doughnut	Check hose cable and reroute if needed. Check sensor for 18 ohms.
	Hose power controller needs replacement	Contact Graco Technical Assistance.
Low heat in hose. Hose power controller in lower cabinet illuminates green light, but amber light not on. Temperature controller 01 output light is on steady.	More than 210 ft (64 m) of heated hose on machine (prevents hose from reaching 45 amps)	Running at full voltage. Orange light only comes on when power controller is at 45 amp current limit. Remove any length of hose over 210 ft.

Primary Heater

Primary heat temperature controller green switch light goes out	Primary heater 230°F (110 °C) over-temperature switch tripped.	Reset heater switch to START after cooling.
	Solid state relay failed closed.	Replace solid state relay 165 SSR.
Primary heat display low; power ON	Temperature setpoint too low	Check setpoint (SP1) and adjust if necessary.
	Fluid flow too high	Use smaller mix chamber; decrease pressure.
	Heating element burned out	Check heater element resistance; see page 17.
	Heating element fuse blown	Determine high current cause; replace fuse; see page 17.
	Fluid too cold for flow rate	Recirculate fluid in supply drum; see Operation manual 311511.
No Primary heat. Temperature controller output light is on. Green switch light is on. Solid state relay indicator light is on.	Contact relay failed (190 CR)	Check for line voltage across contactor. Replace contactor.
	Circuit breaker tripped (110 CB)	Reset circuit breaker; investigate cause.
	Solid state relay failed (165 SSR)	Check for line voltage across relay.
Primary heat temperature controller displays "SbEr"	Open thermocouple	Check Thermocouple connection. Check thermocouple resistance; replace.

Repair

--	--	--	--	--	--	--

Unless otherwise noted, all repair procedures must be completed with incoming power switched OFF and locked out at the source. Any electrical repair or troubleshooting required beyond the scope of this manual must be performed by a qualified electrician. Shut off air inlet ball valve and shut off all air supply pressure.

Shroud Removal

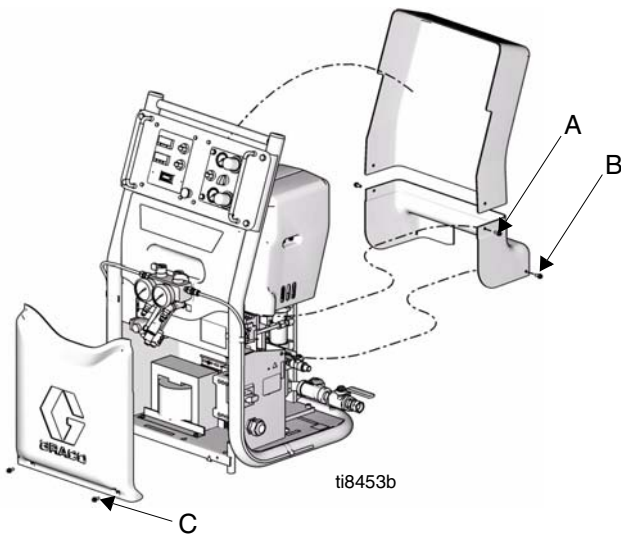

Rear Upper Half

1. Remove two screws (A) on sides of shroud.
2. Lift shroud up over three pins holding it in place at top of Reactor.
3. Lift shroud completely off and remove from Reactor.

Rear Lower Half

1. Remove two screws (B) from lower half of shroud.
2. Pull lower half of shroud up and off to remove from Reactor.

Lower Front Cover

1. Remove two bolts (C) at bottom of front cover.
2. Pull cover down and out to remove from Reactor.

Air Motor Cover

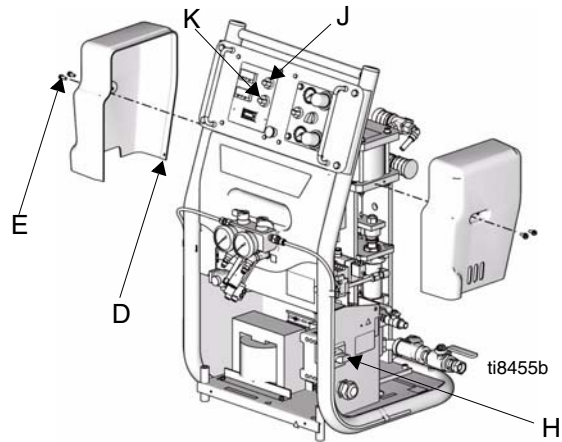

1. Pull out and remove pin (D) holding two shroud halves together.
2. Remove two screws (E) on each side of shroud.
3. Remove fan wires if required.

Pump Removal

--	--	--	--	--	--	--

Air motor shaft, yoke, pump rod and connecting rod move during operation. Moving parts can cause serious injury such as pinching or amputation. Keep hands and fingers away from connecting rod during operation.



See manual 311391 for pump repair instructions.

1. Shut off Primary Heater Switch and Hose Heater Switch.
2. Perform **Pressure Relief Procedure**; see page 7.
3. Perform **Flushing Procedure**; see page 7.
4. Turn Main Disconnect Switch OFF (H) and disconnect power supply.

5. Shut off both feed pumps and close both inlet supply valves (F).

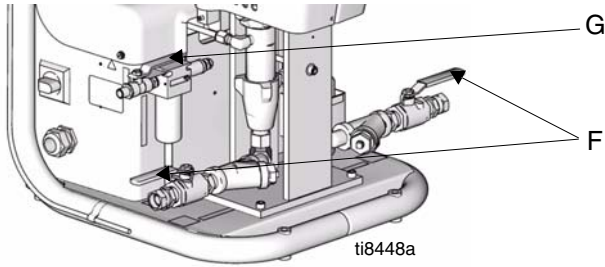

6. Shut off inlet air ball valve (G).
7. Remove air motor cover on side to be repaired; see page 12.
8. Disconnect fittings at inlet (Q) and outlet (M). Also disconnect steel outlet tube (P) from heater inlet.

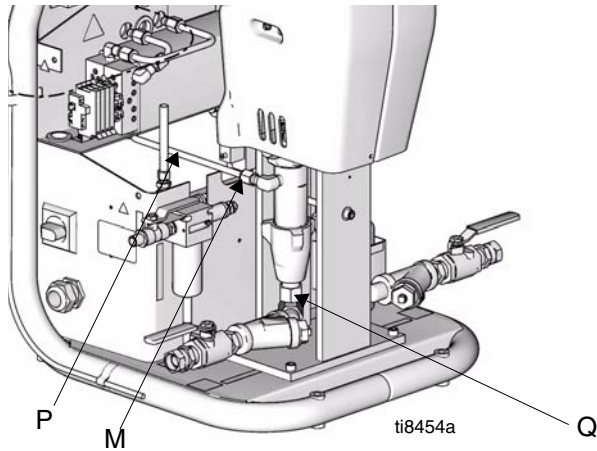

9. Disconnect tubes (N) from Iso Lube Pump on A side only.

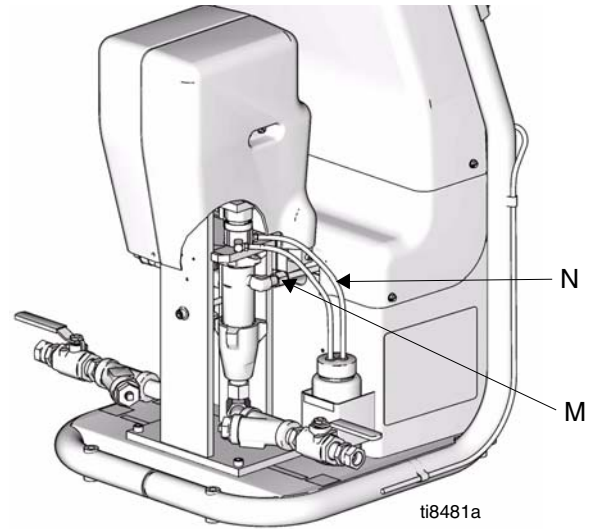

10. Push retaining wire clip (R) up. Push retaining pin out.

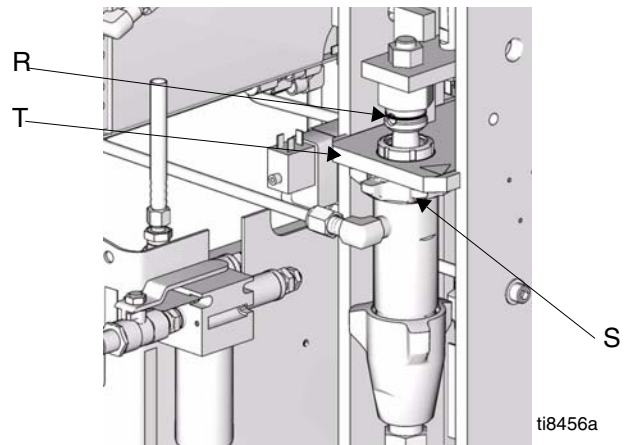

11. Loosen locknut (S) by hitting firmly with a non-sparking hammer.

12. Unscrew pump out of pump mounting plate (T).

Pump Installation

1. Ensure locknut (431) is screwed on pump with flat side up. Grease pump mounting threads in plate (412) with lithium grease. Screw pump into pump mounting plate (401) until top of pump thread is above mounting plate 1/2 to 1 1/2 threads above flush.
2. Align pump rod hole with link hole. Push retaining pin (436) in. Pull retaining wire down to cover pin ends.
3. Reconnect fluid inlet (Q) and outlet (M).

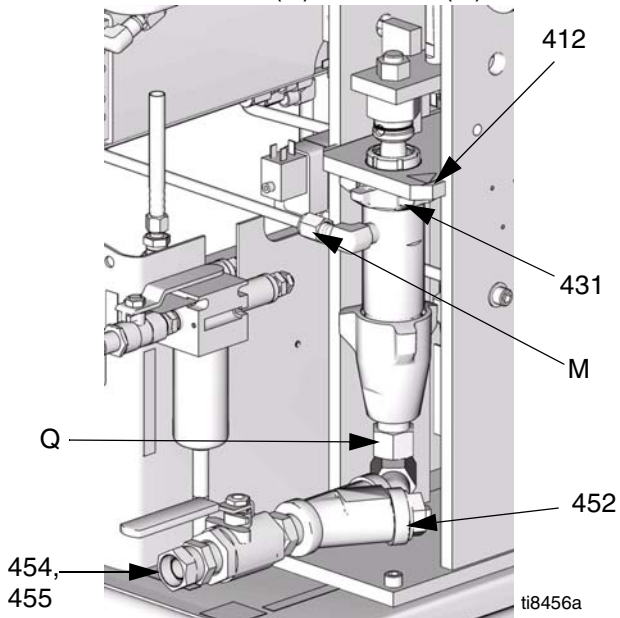

4. Tighten locknut (431) by hitting firmly with a non-sparking hammer.

5. For Iso A pump only: reconnect two tubing lines (N) from ISO Pump Lube reservoir. Flush and refill reservoir with TSL 206995.

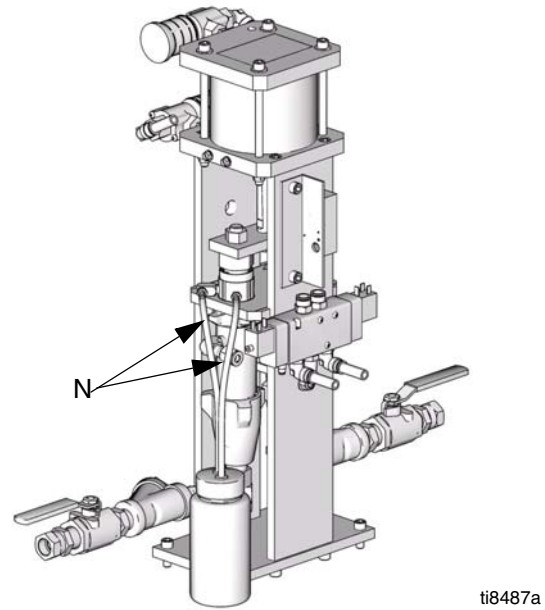

6. Refill Resin B pump wet cup with TSL 206995.
7. Reconnect fan wires if they were disconnected.
8. Reinstall air motor cover and tighten two screws (E).

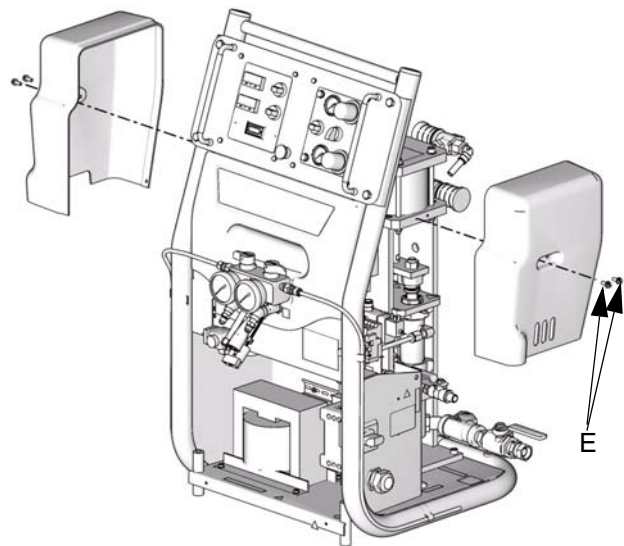

Recirculation / Over Pressure Relief Block

Valves can be serviced with the block on the machine (see page 32 for parts view). For thorough cleaning, remove the block assembly as follows.

1. Remove both rear shrouds and lower front shroud; see page 12.
2. Disconnect two fluid tubes connected to back of recirculation block.
3. Loosen and remove two screws (ST) in back of recirculation block.

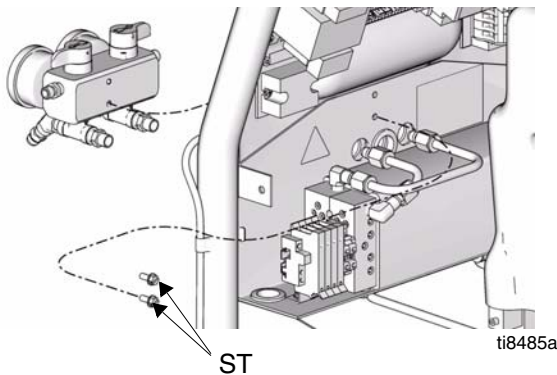

4. See **Relief Manifold**, page 30. Clean and inspect all parts for damage. Ensure that the seat (8a) and gasket (8b) are positioned inside each valve cartridge (8).
5. Apply PTFE pipe sealant to all tapered pipe threads before reassembling.
6. Reassemble in reverse order, following all notes.

Air Motor

See **A-20 Air Motor Pump Assembly** on page 32.

 Air Motor Seal Repair Kit 255057 is available to change all air motor seals.

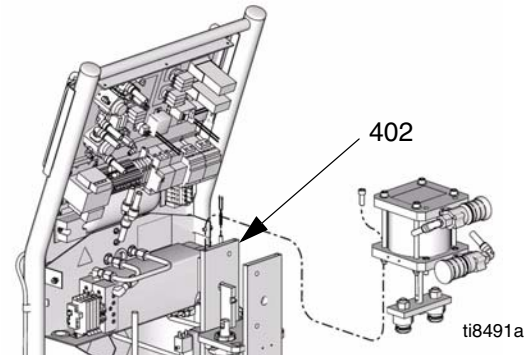

1. Press in tube fitting ferrules and pull out tubing to disconnect air lines.
2. Raise retaining spring (444) and knock retaining pins (436) out of both pump connection links (414). Leave yoke (415) and link (414) in place.
3. Remove four bolts (404) to remove entire air motor assembly.

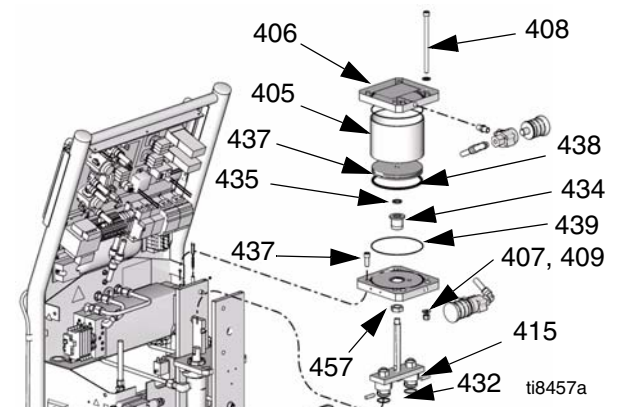

4. Remove lock nut (432) from piston rod (437) and remove pump yoke (415).
5. Remove four lock nuts (409), washers (407), and tie-rod bolts (408).
6. Remove top plate (406) from air cylinder (405).
7. Push piston assembly out of the air cylinder and replace piston o-ring (438) and lubricate. Inspect air cylinder (405) for wear or damage.
8. Remove nut (457). Replace bottom plate bearing (434), u-cup seal (435), and lubricate. U-cup seal open end faces up.
9. Replace top and bottom o-rings (439) in the plates. Use lubricant to hold in place.
10. Assemble in reverse order.
11. Torque tie rod bolts in small increments evenly to 17-22 in/lbs (3•4 Nm).

Reversing Switch

1. Remove single screw and remove cover from reversing switch (410).
2. Inspect parts for damage or wear; replace switch assembly if necessary.
3. Disconnect wire from terminal block (follow wire back to where it connects to terminal block and disconnect).
4. Remove two screws (404) from mounting bracket.
5. Reassemble in reverse order.

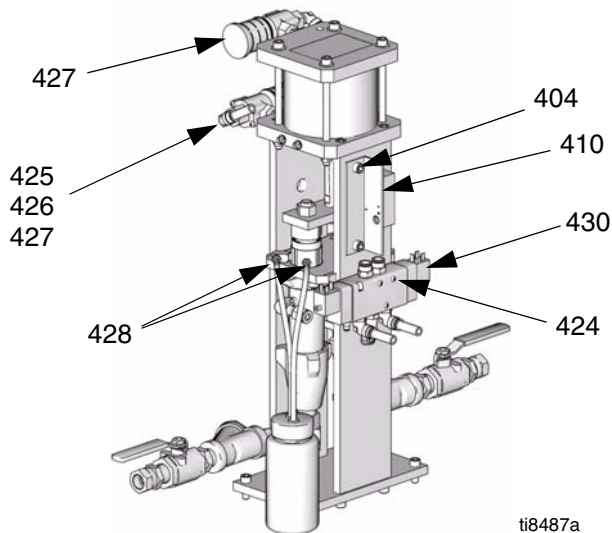

Solenoid Valve Replacement

See **A-20 Air Motor Pump Assembly**, page 32.

1. Disconnect all tubing attached to air control solenoid valve (430). To disconnect, push end sleeve in and pull tube. Mark each tube according to its corresponding fitting.
2. Loosen self-contained plug retaining screw on each end and remove electronic plug.
3. Remove three screws (424) on air control solenoid valve.
4. Replace fittings (425, 426, 428) and muffler (427) onto new valve.
5. Reattach mounting screws and plug retaining screws.
6. Reconnect all tubing lines.

Air Inlet Filter / Water Separator (Auto Drain)

Air Filter Element Removal

See **Air Inlet**, page 30.

1. Close air inlet valve (302) on filter (301).
2. Hold in metal spring clip and twist black cover counterclockwise to remove.

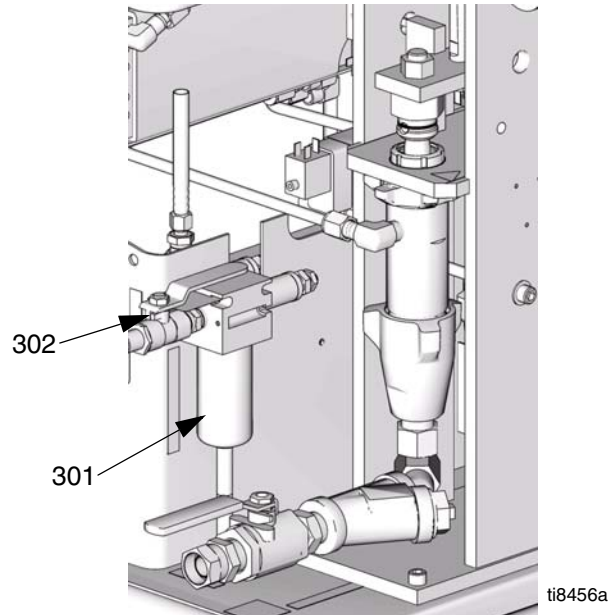

3. Unscrew clear drain cover by hand.
4. Unscrew black filter element retainer to remove element.
5. Inspect filter element. Clean or replace.

Air Filter Element Installation

1. Insert cleaned or replacement filter (114228).
2. Hand-screw filter retainer into place.
3. Hand-screw clear drain cover until tight.
4. Reposition black cover and turn. Make sure it "snaps" back into place.

Primary Heater

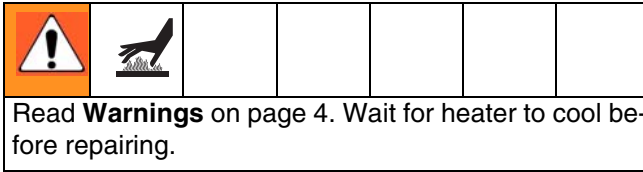

1. Turn Main disconnect Switch OFF.
2. Perform **Pressure Relief Procedure**; see page 7.
3. Wait for heater to cool.
4. Perform **Flushing** procedure; see page 7.
5. Remove both rear shrouds and lower front shroud; see page 12.

Removal

1. Disconnect two fluid lines (10, 11) at bottom of heater.
2. Disconnect two upper fluid lines (8, 9) at the connection to the recirculation manifold. Leave tubing assemblies connected to heater.

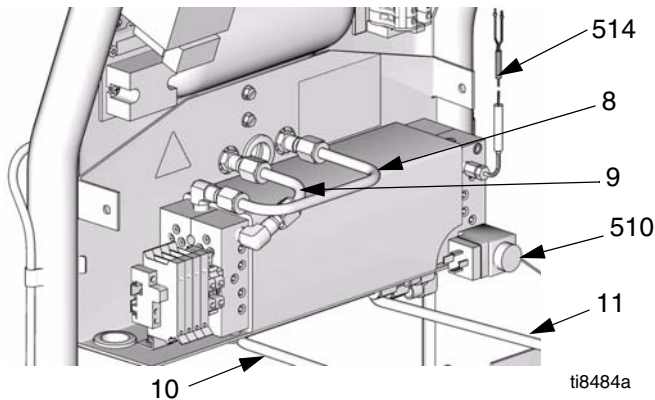

3. Follow brown thermocouple wire (514) up to hose heat temperature control and disconnect. See **Wiring** on page 35.
4. Disconnect over pressure switches. (510)
 - a. Loosen retaining screw.
 - b. Unplug connector front and back.
5. Disconnect two main power leads from wire harness at heater assembly terminal blocks.
6. Disconnect two wires from over temperature switch.

7. Remove back screw holding wiring bracket to heater shelf. Retain screw.
8. Remove four screws (37) underneath heater. Retain four thermal barrier spacers (22) for later installation.
9. Pull heater assembly out and remove from unit.

Service

See parts breakdown on page 34 for servicing.

Installation

Reconnect and install in reverse order.

Heating Elements

The primary heater contains four 1500-watt (30-36 ohms each) heating elements wired in parallel. To check if the elements are functional, perform the following steps:

1. Turn OFF and lock out incoming power at source.
2. Allow heater to cool.
3. Remove two rear shrouds; see page 12.
4. Measure the resistance of all four heating elements wired in parallel together at the heater contactor.

When measured at points T1 on 165 SSR and T3 on 190 CR (see figure below), ohms reading should be 8.5. If ohm reading is above 10 ohms, see step 5.

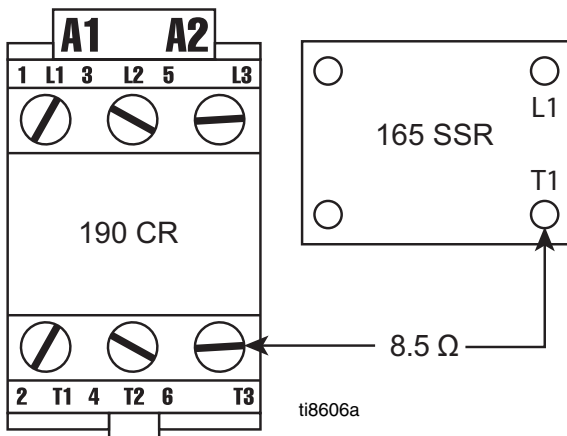

5. Check each fuse in fuse holder. Swing open fuse holder by pulling on tab. Test each fuse for electrical continuity from end to end. Replace if open resistance is measured. If fuses are good, see step 6.
6. Measure resistance of two heating elements wired in parallel with fuse holders open.

Resistance between 1A and 2A to be 17 ohms.
Resistance between 1B and 2B to be 17 ohms.

If resistance is higher than 25 ohms, determine which heating element is failed open. Disconnect each heating element wire from fuse holder and measure resistance.

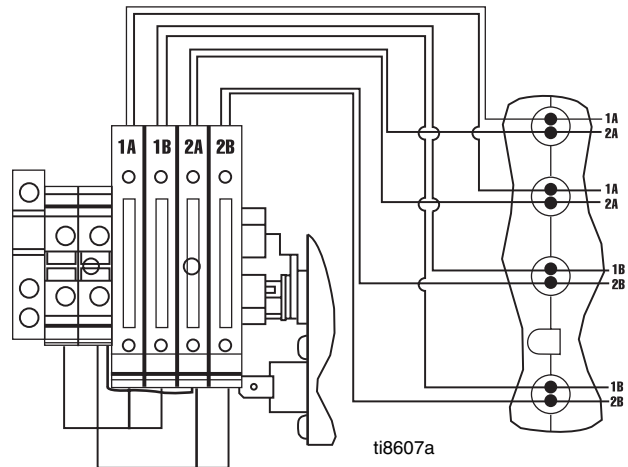

7. Each heating element resistance reading should be 34 ohms.

Fluid Inlet Filter Screen



A Y-line filter screen before each proportioning pump traps solid matter to ensure proper operation of ball check valves in pump base. Inspect and clean both screens. See Reactor A-20 Operation manual (311511).

 Regularly clean isocyanate pump screen during start-up procedure. This minimizes moisture contamination problems by immediately flushing out any isocyanate residue at start of dispensing operation.

Remove and clean filter screens as follows:

1. Follow **Pressure Relief Procedure** on page 7.
2. Place a rag beneath filter base to catch drain-off of chemical when removing screen plug.
3. Loosen screen plug just enough to allow material to drain out onto rag.
4. Unthread screen plug and remove it.
5. Pull screen straight out of strainer. Clean or replace. See **Accessories**, page 24, for alternate mesh size.
6. Thoroughly clean screen gasket and material inside strainer.
7. Position screen on shoulder of plug and screw securely back into strainer.
8. Reconnect transfer pump air supply and open material inlet supply valve. Ensure there are no leaks and wipe equipment clean.

Isocyanate Pump Lubricant

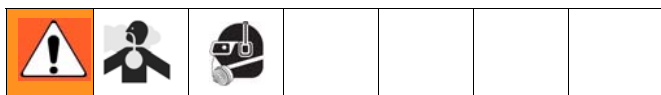

Check pump lubricant daily. Change lubricant before it becomes a gel or when its color darkens. The time interval between changes due to gel formation will depend on environmental conditions.

To change lubricant, use the following steps.

1. Lift lubricant reservoir out of bracket and remove reservoir from cap.
2. Flush reservoir thoroughly and fill 3/4 full with TSL Throat Seal Lubricant 206995.
3. Thread reservoir back onto cap assembly and return it to the bracket.

The lubrication system is now ready from operation. No priming is required.

Fluid Temperature Sensor (FTS)

Check FTS operation by connecting directly to Reactor.

 An alternating hose controller display of SbEr and H20.00 indicates a loss of signal from the FTS. Two conditions must be satisfied for proper FTS operation:

- The sensor must be functional
- The signal must travel uninterrupted from the sensor to the control unit

FTS Cable Test

1. Disconnect FTS cable (SS) at Reactor.

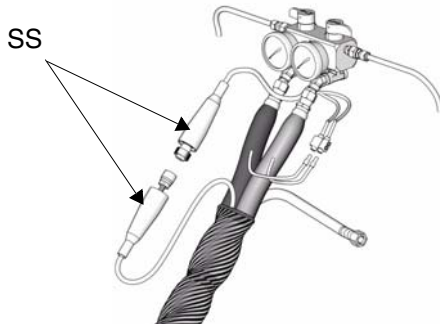

ti8444b

2. Test with ohmmeter between pins of cable connector.

Pins	Result
1 to 2	Approximately 35 ohms per 50 ft (15.2 m) of hose, plus approximately 10 ohms for FTS
1 to 3	Infinity

3. If cable fails test, retest at FTS.

FTS Test

1. Turn Main Disconnect Switch OFF. Disconnect power supply cord.
2. **Relieve pressure**; see page 7.
3. Remove tape and protective covering from FTS. Disconnect hose cable. Test with ohmmeter between pins of cable connector.

Pins	Result
1 to 2	Approximately 35 ohms per 50 ft (15.2 m) of hose, plus approximately 10 ohms for FTS
1 to 3	Infinity
3 to FTS ground screw	0 ohms
1 to FTS component A fitting (ISO)	Infinity

4. If FTS fails test, replace FTS.

Removal

1. Disconnect air hoses (C, L) and electrical connectors.
 2. Disconnect FTS from whip hose and fluid hoses.
 3. Remove ground wire (MM) from ground screw on underside of FTS.
 4. Remove FTS probe (UU) from component A (ISO) side of hose.
1. Carefully extend FTS probe (UU). Do not bend or kink probe. Insert in component A (ISO) side of main hose.
 2. Connect whip hose ground wire (MM) to ground screw on underside of FTS.
 3. Install FTS in reverse order of removal. Leave slack in cables as stress relief, to prevent cable failure.
 4. Secure hose and cable connection with tape and install protective covering.

Installation

CAUTION

To prevent damage to probe, do not kink or excessively bend whip hose. Do not coil hose tighter than the minimum bend radius of 3 ft (0.9 m). Do not subject hose to excessive weight, impact, or other abuse.

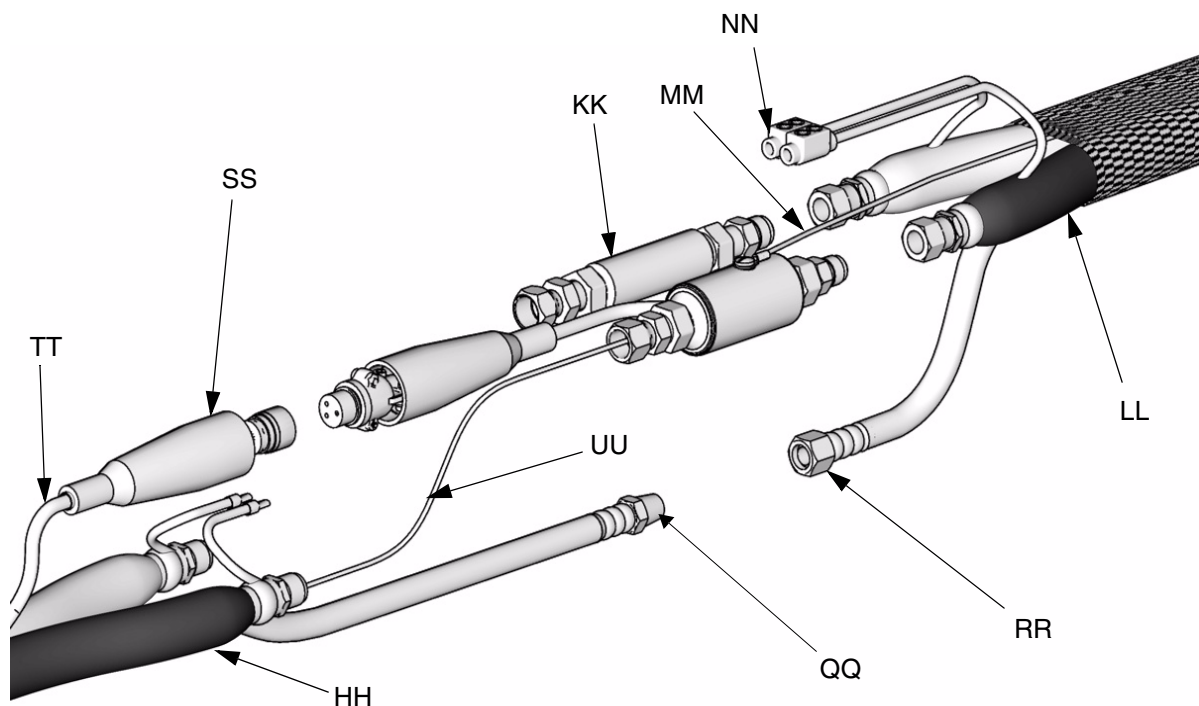

ti9581b

FIG. 1: Fluid Temperature Sensor and Heated Hoses

Replacing Control Components

Hose Power Controller / Circuit Breaker / Relays

Hose Heat Power Controller and Hose Transformer Secondary Circuit Breaker are DIN rail-mounted in the lower cabinet. Unsnap them from the DIN to replace them. See **Electrical Control Panel**, page 28.

Hose Heat Power Controller

Place flat blade screwdriver under controller and pry spring-loaded release tab above fan and against back wall. Pivot bottom of unit towards front.

Circuit Breakers and Power Contactor Relays

Pry tab on bottom down. Pivot bottom relays towards front.

Digital Temperature Controller

1. Carefully pry tabs away on back sides of case and pull black wire connector off of controller.
2. Squeeze in side tabs on black retainer clip.
3. Pull clip off of controller.
4. Push controller out towards front.

Rotating Panel Switches

1. Push down thumb tab on back of switch assembly.
2. Pull contact block assembly straight back.
3. Use a small blade to unclip contact blocks and light blocks.
4. Unscrew round nut on back of knobs to remove.

Counter

1. Pry tabs of retaining clip away from top and bottom of counter body.
2. Push counter out from back towards front.

Red Stop Switch

1. Remove yellow locking tab on back of switch.

2. Rotate metal tab counterclockwise.
3. Pull contact block straight back and off.
4. Unscrew round nut on back of knob to remove.

Checking Heated Hose Power Controller

The controller, next to the hose transformer in the lower compartment, requires four conditions to be met for proper function:

- 210 - 240 Vac to power the controller
- 4.5 - 5.5 Vdc to operate the control circuit
- a complete electrical circuit through the hose heaters, transformer secondary, and secondary circuit breaker.
- transformer secondary current sensor connected with hose cable running through sensor doughnut.

If these four conditions are met, one green and one orange status lights are illuminated. This only happens if the hose temperature controller output light is on. If the temperature controller light is flickering on less than 50%, the orange light may not be illuminated. No more than 210 ft of hose on the machine.

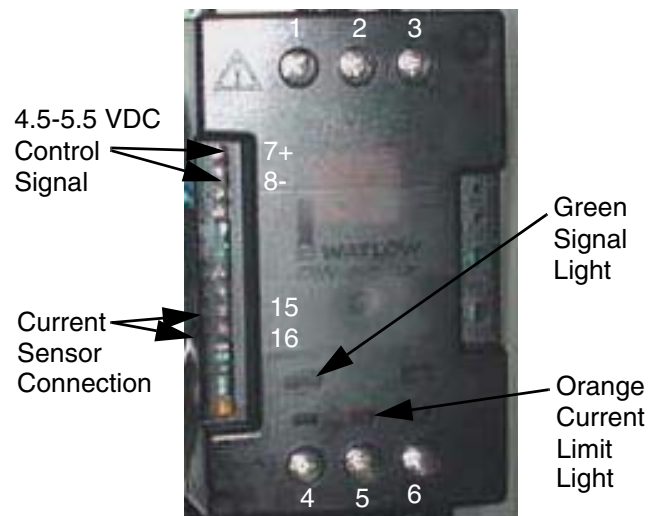

- 5.





Hose Heat Manual Mode

If the hose temperature controller does not see the Fluid Temperature Sensor (FTS), it will shut off the hose heat and give a flashing error alternating between:

SbEr = Sensor break error
H20.0 = Heat output 20%

The hose can be manually heated by turning the hose back on with the hose switch and green light. The up/down arrows can be used to adjust the default 20% power output.

There is no monitoring or alarm in manual mode. You must monitor the temperature by inserting a probe thermometer inside the hose insulation against the hose. The thermometer will read 10-20 °F less than actual fluid temperature. Repair the temperature sensor or cable as soon as possible to avoid damaging the heated hose.

						
<p>Do not allow hose to overheat during manual control. Hose temperature, as indicated by a properly installed hose thermometer, must not exceed 170 °F (76 °C). Closely monitor hose temperature to avoid personal injury or damage to property.</p>						

Checking Heated Hose Current Sensor

The hose current sensor is a small “D” shaped black plastic coil with two small wires coming to terminals (15, 16) of the Hose Power Controller. The “D” coil itself has one of the large wires from the hose transformer secondary running through it.

1. Disconnect either wire at connection 15 or 16.
2. Connect ohm meter to the disconnected wire and to the connected wire at terminal.
3. Resistance across the sensor should read approximately 18 ohms on the meter.

Air Motor Up / Down / Pressure Regulators / Gauges

Regulators

Unscrew block nut on front of panel. Push regulator out to the back.

Gauges

1. Remove air fitting.
2. Remove brass nut and clamp.
3. Push gauge out to front.

Control Panel Wiring

Every wire has a component number followed by a dash and a number, which indicates the terminal location. Refer to schematic and labels on back of panel.

Accessories

Feed Pump Kits

Pumps, hoses, and mounting hardware to supply fluids to Reactor. Includes 246483 Air Supply Kit. See 309815.

246483 Air Supply Kit

Hoses and fittings to supply air to feed pumps, agitator, and gun air hose. Included in feed pump kits. See 309827

246978 Circulation Kit

Return hoses and fittings to make circulation system. Includes two 246477 Return Tube Kits. See 309852.

246477 Return Tube Kit

Desiccant dryer, return tube, and fittings for one drum. Two included in 246978 Circulation Kit. See 309852.

255057 Air Motor Seal Kit

Includes piston rod seal and bearing, piston and cylinder o-rings.

TSL (Throat Seal Liquid)

206995 1 qt (1 liter) bottle

206996 1 gal. (3.8 liter) container

Heated Hoses

50 ft (15.2 m) and 25 ft (7.6 m) lengths, 1/4 in. (6 mm), 3/8 in. (10 mm), or 1/2 in. (13 mm) diameter, 2000 psi (14 MPa, 140 bar) or 3500 psi (24 MPa, 241 bar). See 309572.

Heated Whip Hoses

10 ft (3 m) whip hose, 1/4 in. (6 mm) or 3/8 in. (10 mm) diameter, 2000 psi (14 MPa, 140 bar) or 3500 psi (24 MPa, 241 bar). See 309572.

Fusion Spray Gun

Air Purge Gun available in round or flat pattern. See 309550. Mechanical Purge Gun available in round or flat pattern. See manual 309856.

Y-Strainer Screen

Replacement strainer screen for fluid Y-strainer; 20 mesh.

Part	Description
180199	20 mesh; as shipped
255082	80 mesh (2 pack)
255083	80 mesh (10 pack)

114228 Air Filter Element

Replacement air filter element; 5 micron.

Recommended Spare Parts

Keep the following spare parts on hand to reduce downtime.

Part No.	Description
245971	Pump, Resin (B) side
246421	Resin (B) Pump Repair Kit for 245971 pump
246831	Pump, ISO (A) side
15C851	ISO (A) Pump Repair Kit for 246831 pump
246963	Wet Cup Kit for 246831 pump
206995	TSL bottle, 1 qt (1 liter)
101078	Y-Strainer; includes 180199 element
180199	Element, Y-Strainer, 20 mesh
114228	Element, air filter, 5 micron
255057	Kit, Air Motor Seal
108636	Muffler (qty 2)
239914	Valve, recirc/spray; includes seat and gasket
120624	Fuse, heating element (qty 4)
260938	Heating element (qty 4)
116225	Fuse, control power (qty 3)

Parts

Reactor A-20

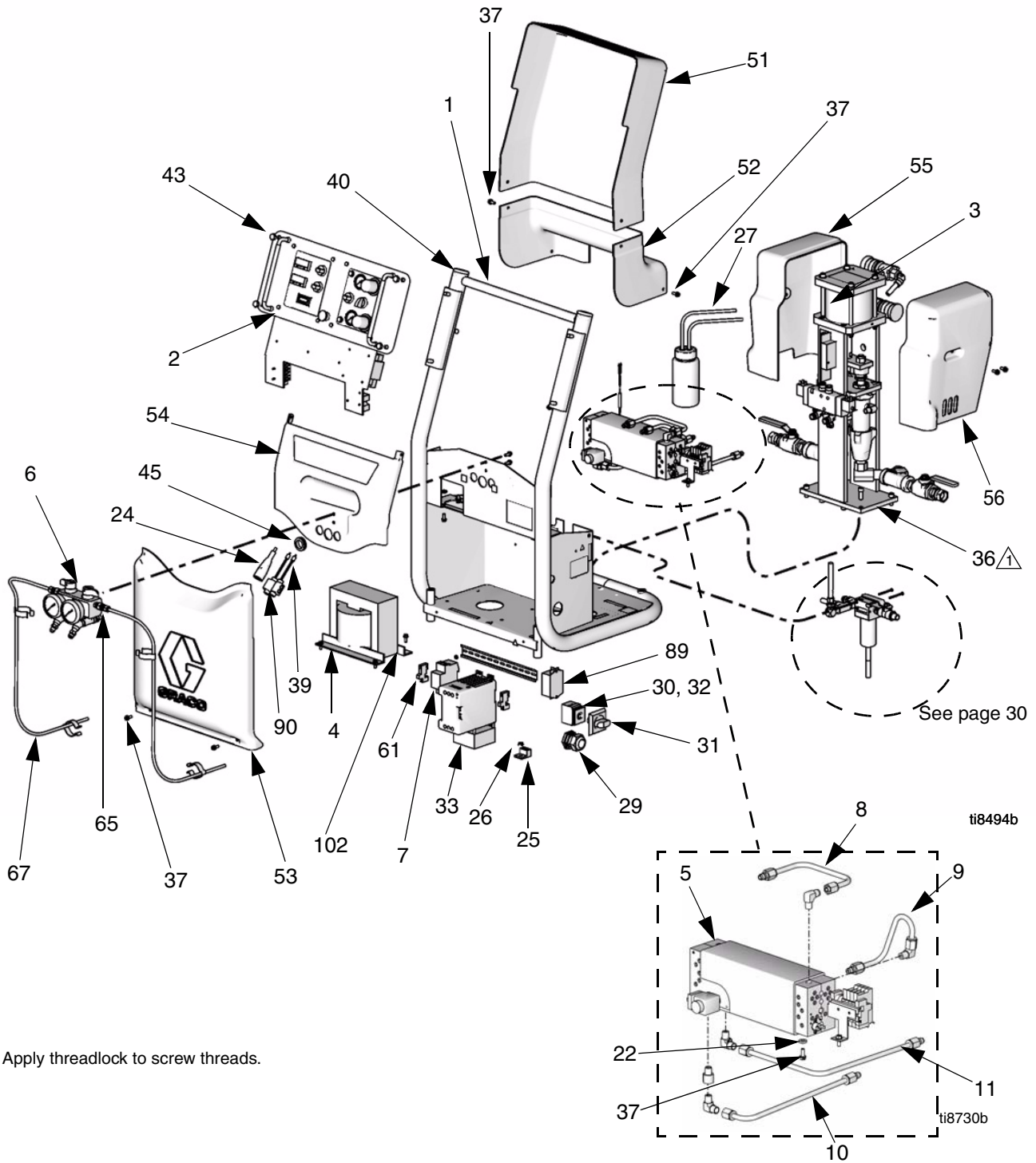

FIG. 2: Reactor A-20

Reactor A-20

Ref.	Part	Description	Qty.	Ref.	Part	Description	Qty.
1		CART, assy.	1	74†	261669	SENSOR, fluid temperature	1
2		PANEL, control, electrical; see page 28	1	78†▲	189285	LABEL, caution, hot	1
3		PUMP, air motor; see page 32	1	89	120616	FILTER, electrical	1
4	15J349	TRANSFORMER, 2790VA, 230/62	1	90	261821	CONNECTOR, wire	1
5		HEATER, 6000W, primary; see page 34	1	102	113796	SCREW, flanged	4
6		MANIFOLD, relief; see page 30	1	▲ Replacement Danger and Warning labels, tags, and cards are available at no cost.			
7	120579	CIRCUIT BREAKER, 50 amp	1	† Not shown.			
8	15H837	TUBE, fluid, A (outlet), A-20	1	* See Electrical Control Panel , page 28.			
9	15H836	TUBE, fluid, B (outlet), A-20	1				
10	15H963	TUBE, fluid, A (inlet), A-20	1				
11	15H962	TUBE, fluid, B (inlet), A-20	1				
22	167002	INSULATOR, heat	4				
23	120550	FITTING, tube, union Y, 1/2 OD	1				
24	15B380	CABLE, FTS	1				
25	117666	TERMINAL, ground	1				
26	115942	NUT, hex, flange head, 1/4-20; see manual 309911	1				
27	246995	BOTTLE, assembly, complete	1				
29	117682	BUSHING, strain relief, PG29	1				
30	120571	SWITCH, disconnect, 40A	1				
31	120572	KNOB, disconnect, operator	1				
32	120580	SWITCH, fourth pole	1				
33	120387	CONTROL, hose power, 240V	1				
35*	114128	FITTING, elbow, male, swivel	4				
36	C19837	SCREW, cap, socket hd, 3/8-16 x 1	4				
37	108296	SCREW, hex washer hd, 1/4-20	16				
39	15J224	WIRE, high current to hose	1				
40	112125	PLUG, tube	2				
41*	114151	FITTING, elbow, male, swivel	4				
42*	100451	COUPLING	2				
43	117623	NUT, cap (3/8-16)	4				
45	114269	GROMMET, rubber	1				
46*	113505	NUT, keps, hex hd, 10/24	3				
47†▲	15G280	LABEL, warning	1				
51	253894	COVER, controls, rear	1				
52	253893	COVER, elect, rear	1				
53	253891	COVER, elect, front	1				
54	253892	COVER, controls, front	1				
55	253895	COVER, motor, left	1				
56	253896	COVER, motor, right	1				
57†	120302	CASTER, friction post, 3 in. wheel	4				
61	112446	BLOCK, clamp end	2				
62*	116513	REGULATOR, air	2				
63†*	116514	NUT, regulator mnt	2				
64*	116257	GAUGE, pressure	2				
65	205447	COUPLING, hose	2				
66	054826	TUBE, plastic, PTFE, 6 ft	1				
67	186494	CLIP, spring	4				
71†▲	189930	LABEL, caution, electric	1				
72†	172953	LABEL, ground	1				

Electrical Control Panel

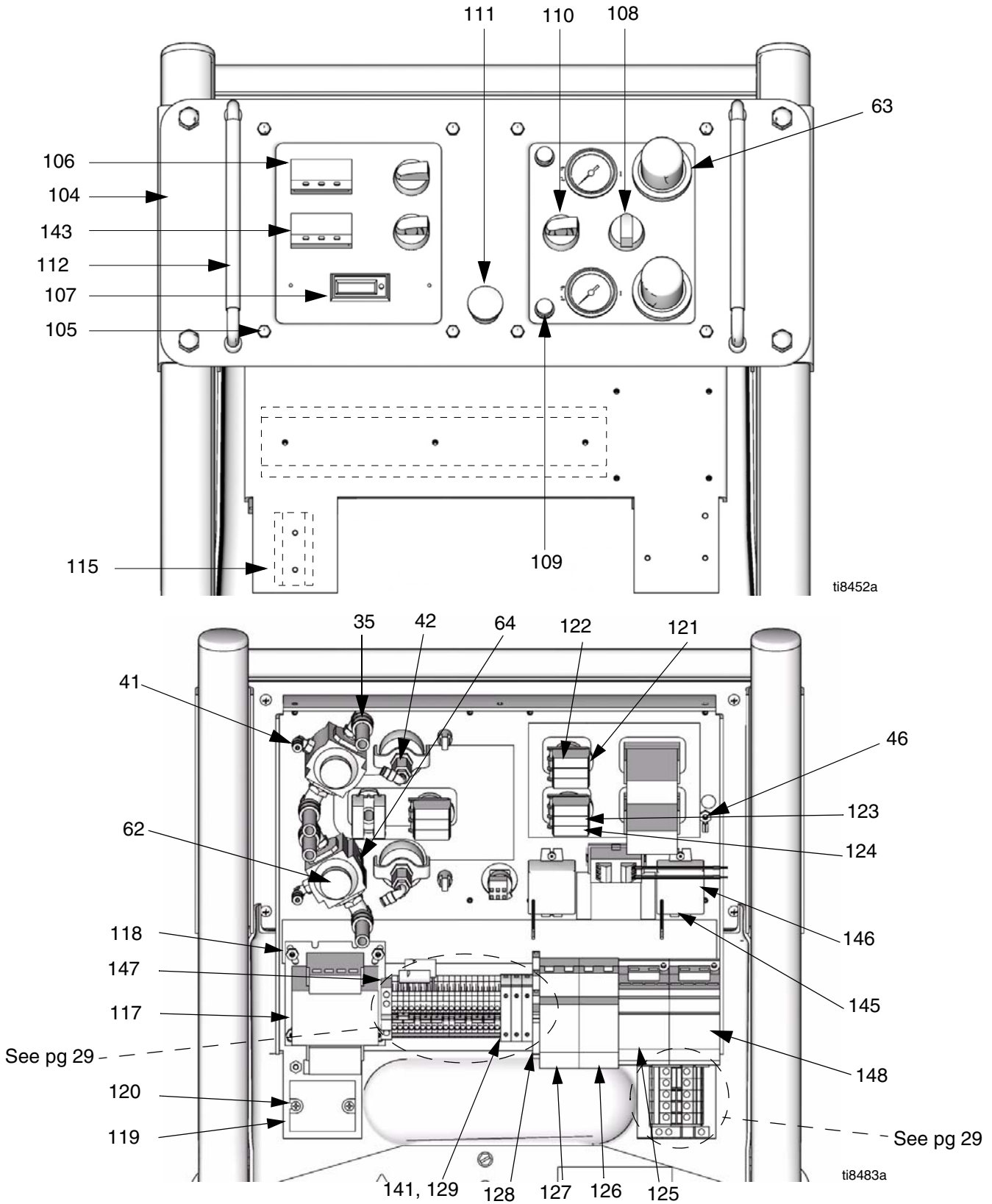
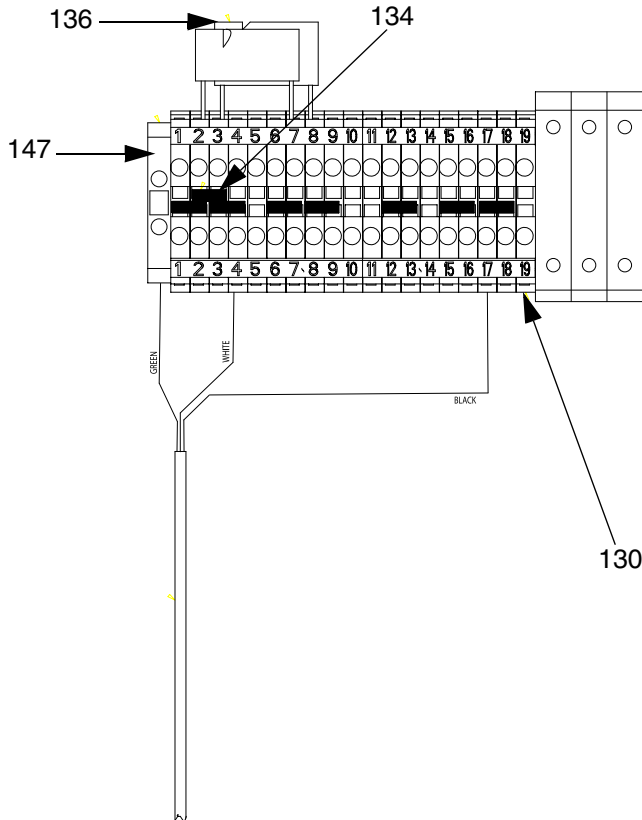

FIG. 3: Electrical Control Panel

Electrical Control Panel

Ref. Part	Description	Qty.
104	15B291 PLATE, display	1
105	117523 NUT, cap (#10)	8
106	15J591 CONTROLLER, temp, heater (w/software)	1
107	296825 COUNTER, digital	1
108	120497 SWITCH, selector, two position	1
109	120526 LIGHT, indicator, 120 volt	2
110	120492 SWITCH, three position, lighted	3
111	117500 SWITCH, e-stop	1
112	117499 HANDLE, large	2
115	RAIL, mounting, 3 in.	1
117	120482 TRANSFORMER	1
118	113505 NUT, keps, hex hd, 10-24	8
119	120479 RELAY, SSR, heater	1
120	103196 SCREW, mach pan hd, 8-32	4
121	120493 LATCH, mounting	4
122	120494 BLOCK, switch, N.O., red	4
123	120496 BASE, light, LED	3

Ref. Part	Description	Qty.
124	120495 BLOCK, switch, N.C., green	4
125	120498 RELAY, contactor, hose	2
126	295351 CIRCUIT BREAKER, 16A, 2P	1
127	295355 CIRCUIT BREAKER, 32A, 2P	1
128	120489 RELAY, pump circuit	1
129	514556 HOLDER, fuse term. block (5x20 mm)	3
130	120491 BLOCK, terminal	19
131	120490 COVER, end	1
132	112446 BLOCK, clamp end	3
133	120570 BLOCK, terminal	5
134	120485 BRIDGE, plug-in, (jumper)	8
135	120573 BRIDGE, plug-in, (jumper)	2
136	295472 CAPACITOR	2
141	116225 FUSE, bussmann, gdc-1a (5x20 mm)	3
143	15J590 CONTROLLER, temp, hose (w/software)	1
145	102794 NUT, hex, 4-40	4
146	120582 FILTER, noise, SSR	2
147	112443 BLOCK, terminal ground	1
148	120656 RELAY, contactor, heater	1



Electrical Control Panel - Detail

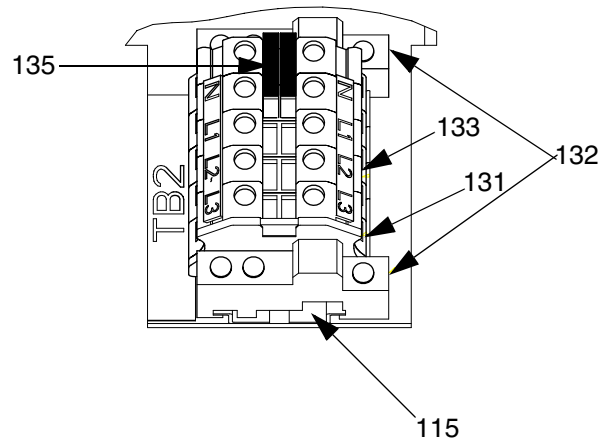

Relief Manifold

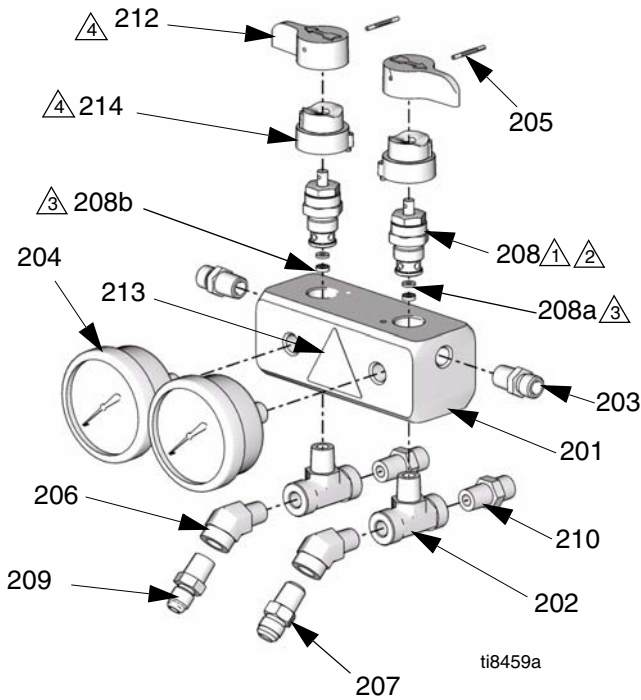

- ① Apply sealant and torque to 250 in-lbs (28 N•m)
- ② Use blue thread lock on valve cartridge threads into manifold
- ③ Part of item 208
- ④ Apply lubricant to mating surfaces
- ⑤ Apply pipe sealant to all NPT threads

FIG. 4: Relief Manifold

Ref. Part	Description	Qty.
201	15F870 MANIFOLD, recirculation	1
202	108638 FITTING, pipe, tee	2
203	162453 FITTING, (1/4 npsm x 1/4 npt)	2
204	113641 GAUGE, pressure, fluid, SST	2
205	111600 PIN, grooved	2
206	119789 FITTING, elbow, street, 45 deg,	2
207	116704 ADAPTER, 9/16-18 JIC (#6) x 1/4 npt	1
208	239913 VALVE, drain; includes 208a, 208b	2
208a	SEAT	2
208b	GASKET	2
209	119998 ADAPTER, 1/2-20 JIC (#5) x 1/4 npt	1
210	119983 FITTING, union, 1/4 npt x 3/8 tube	2
212	187625 HANDLE, valve, drain	2
213	189285 LABEL, caution	1
214	224807 BASE, valve	2

Air Inlet

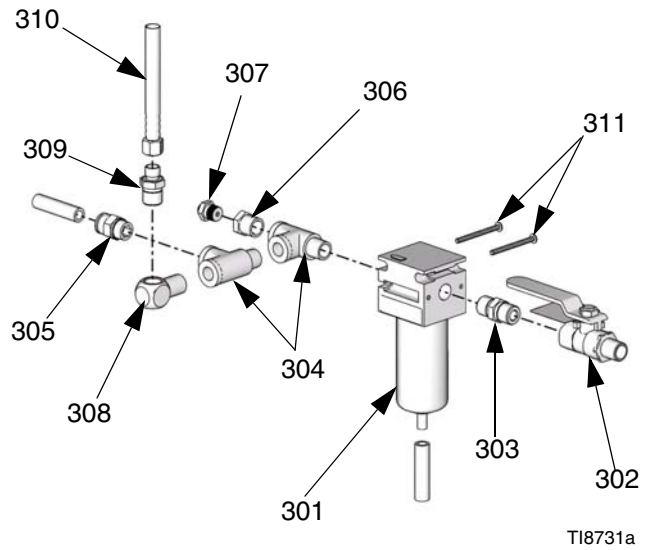

FIG. 5: Air Inlet

Ref. Part	Description	Qty.
301	117629 FILTER, air, 3/8 (auto drain)	1
302	113333 VALVE, ball, vented, 0.375	1
303	156849 PIPE, nipple	1
304	803088 FITTING, tee, street	2
305	114129 FITTING, connector, male	1
306	100176 BUSHING, hex	1
307	15D916 FITTING, straight 5/32 to 1/4 npt	1
308	155699 FITTING, elbow, street	1
309	164672 ADAPTER	1
310	15B772 HOSE, air, 18 in.	1
311	SCREW, pan head, 8-32 x 2 in.	2



A series of horizontal lines spanning the width of the page, providing a template for writing or drawing.

A-20 Air Motor Pump Assembly

Ref.	Part	Description	Qty.	Ref.	Part	Description	Qty.
401	15J138	PLATE, base, pump	1	453	109077	VALVE, ball, 3/4 npt	2
402	15J131	PLATE, side	2	454	296178	FITTING, union, swivel, 3/4 mpt x 1/2 fpt	1
403	15J587	PLATE, cylinder, air, bottom	1	455	157785	FITTING, swivel	1
404	C19837	SCREW, cap, socket hd, 3/8-16 x 1	10	456	C20651	FITTING, elbow, 45 deg, 3/4 npt(m)	2
405	297411	CYLINDER, air	1	457	121601	NUT, acetal, 1 1/8-12	1
406	15J586	PLATE, cylinder, air, top	1	<i>† Not shown.</i>			
407	101971	WASHER, thrust, 3/8	10	<i>★ See manual 309577.</i>			
408	120557	SCREW, cap, socket hd	5				
409	101566	NUT, lock	5				
410	296111	SWITCH, reversing	1				
410a†	295476	SWTICH, micro	1				
410b†	297276	SHAFT, pivot	1				
410c†	297280	LEVER, roller, assy.	1				
410d†	297318	WASHER, fiber	1				
410e†	295418	SPRING	1				
411	15J134	ACTUATOR, switch	1				
412	15J133	PLATE, mounting, pump	1				
413	246831	PUMP, displacement, w/lube, 0.552	1				
414★	15J132	LINK, connecting	2				
415★	15J135	PLATE, yoke, pump	1				
416★	191892	FITTING, elbow, street, 90 deg	1				
417★	193031	NUT, retaining	2				
418★	120543	FITTING, elbow, 3/8 npt x 3/8	2				
419★	245971	PUMP, resin	1				
421	114114	FITTING, elbow, male, swivel	2				
422	114129	FITTING, connector, male	2				
423	112166	SCREW, cap, sch, 1/4-20 x 3/4	1				
424		SCREW, pan head, phillips, 8-32 x 2	3				
425	114128	FITTING, elbow, male, swivel	2				
426	297439	VALVE, quick exhaust	2				
427	108636	MUFFLER	2				
428	116746	FITTING, barbed, plated	2				
429	111328	CONNECTOR, male	1				
430	120522	VALVE, control, air	1				
431	120553	NUT, center lock, 5/8-18	2				
432	120552	NUT, center lock, 1/2-20	1				
433	104765	PLUG, pipe headless	2				
434	15J149	BUSHING, rod, air motor	1				
435	120554	SEAL, u-cup, bevel lip	1				
436	183210	PIN, str, hdls	2				
437	297372	PISTON, air, w/ rod	1				
438	296113	O-RING, #350, buna-n	1				
439	296112	O-RING, #049, buna-n	2				
440	120551	MUFFLER, bronze, sintered	1				
442	156971	FITTING, nipple, short	2				
444	183169	SPRING, retaining	2				
450	156589	FITTING, union, adapter, 90 deg	2				
451	C20487	FITTING, nipple, hex	2				
452	101078	STRAINER, Y	2				
452a†	180199	SCREEN, 20 mesh	1				

Primary 6000W Heater

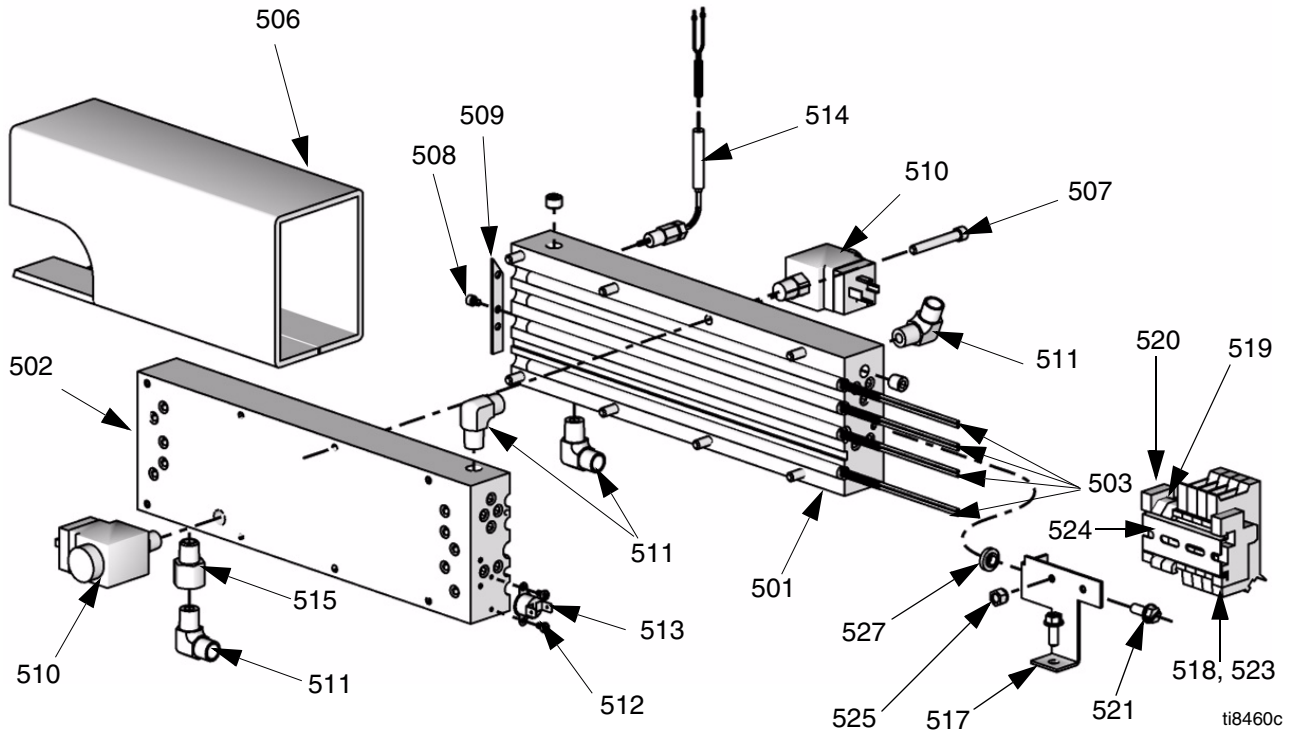

FIG. 7: Primary 6000W Heater

Ref.	Part	Description	Qty.
501	288352	HEATER, B, kit	1
502	288353	HEATER, A, kit	1
503	260938	ELEMENT, heating 1500 watt	4
506	15H960	INSULATOR, heater	1
507	297258	SCREW, cap, socket head	8
508	295732	SCREW, cap, sh, 8-32 x 1/4 lg	1
509	297529	STOP	1
510	296821	SWITCH, pressure, 2200 psi	2
511	119891	FITTING, elbow, 1/4 npt x 3/8 tube	4
512	103854	SCREW, mach, bdgh, 6-32	2
513	15B137	SWITCH, over temperature	1
514	117484	SENSOR, thermocouple	1
515	113336	ADAPTER, 1/4 nptm, 1/4 nptf	1
517	15J583	BRACKET, mounting, fuse	1
518	120621	FUSE, block	4
519	120570	BLOCK, terminal	2
520	112446	BLOCK, clamp end	1
521	108296	SCREW, mach, hex, washer hd, 1/4-20	1
523	120624	FUSE, electrical, MDA-20, 1/4 x 1 1/4	4
524	295261	RAIL, mounting	2
525	113505	NUT, keps, hex hd, 10-24	2
527	110533	WASHER, flat, nylon, 1/4	1



A series of horizontal lines spanning the width of the page, providing a template for writing or drawing.

Air Tubing Connections

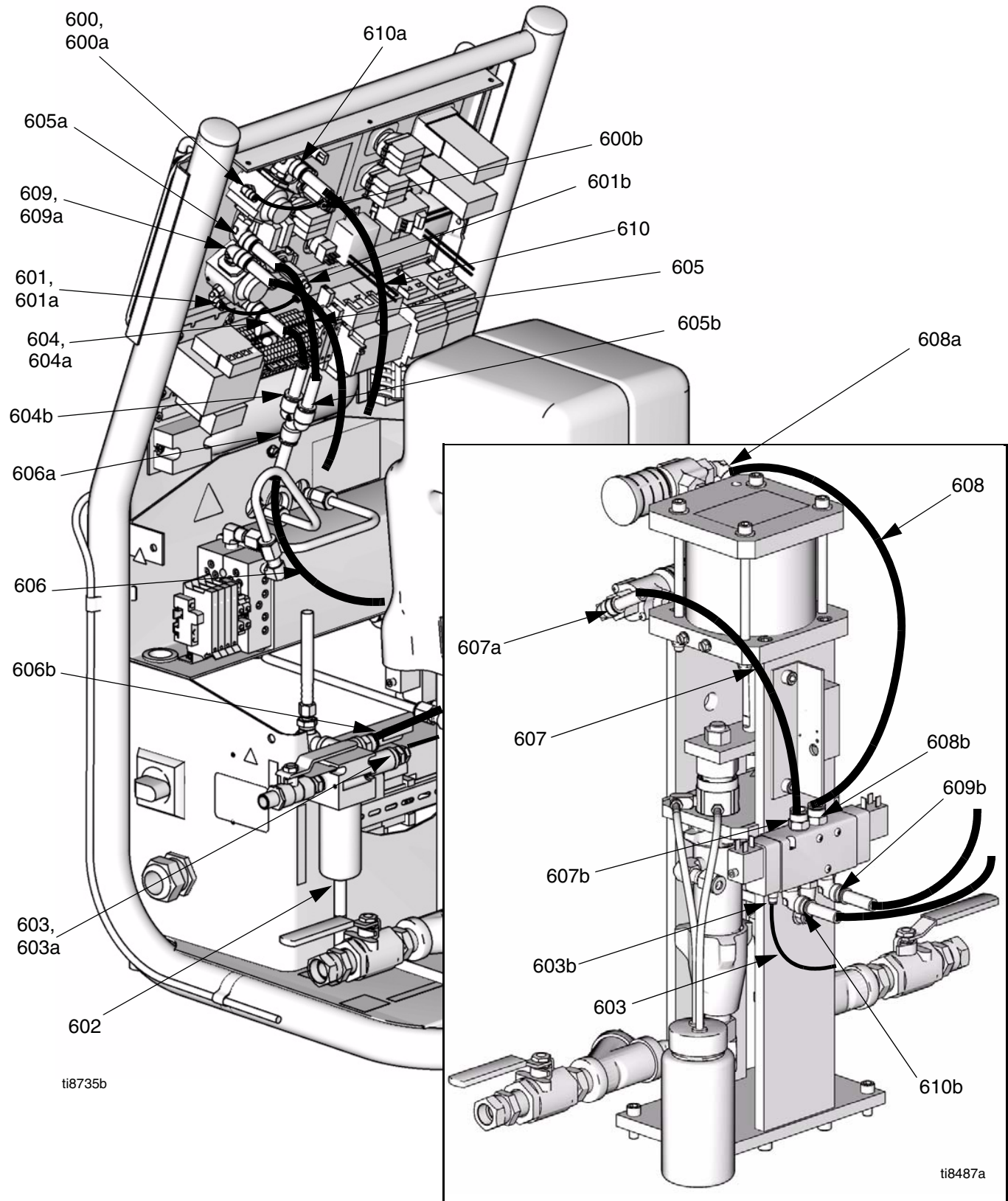

FIG. 8: Air Tubing Connections

Air Tubing Connections

Item	Ref.	Length in. (mm)	Connection	
			From	To
Y	600	4.5 (114.3)	600a	600b
Y	601	4.5 (114.3)	601a	601b
X	602	5.0 (127)	602a	602b
Y	603	7.5 (190.5)	603a	603b
X	604	9.0 (228.6)	604a	604b
X	605	12.0 (304.8)	605a	605b
X	606	19.0 (482.6)	606a	606b
X	607	14.5 (368.3)	607a	607b
X	608	18.5 (469.9)	608a	608b
X	609	29.0 (736.6)	609a	609b
X	610	35.0 (889)	610a	610b

X = TUBE, 1/2 in. OD, polyurethane

Y = TUBE, 5/32 in. OD, polyethylene

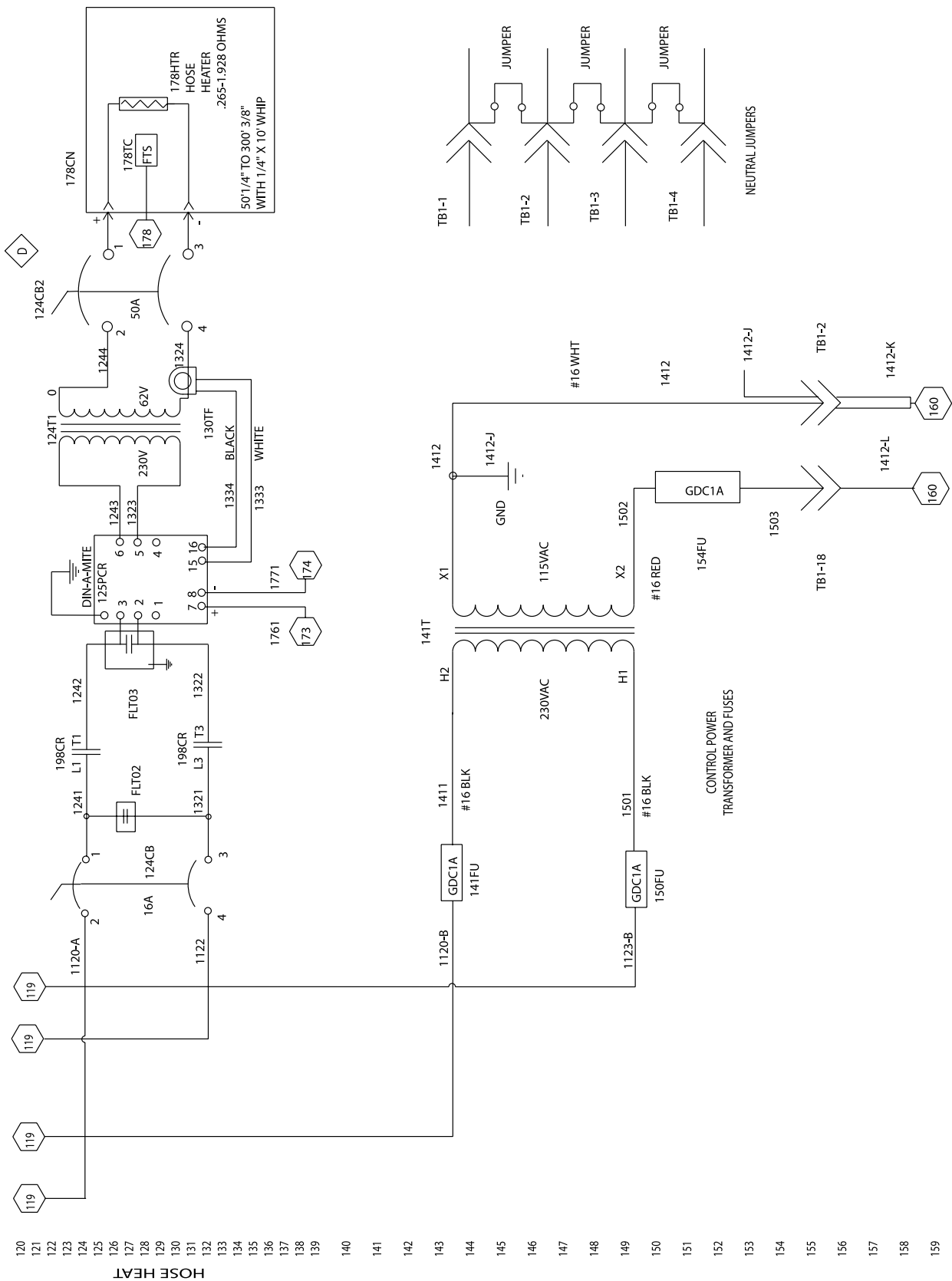

Reactor A-20 Wiring Schematic

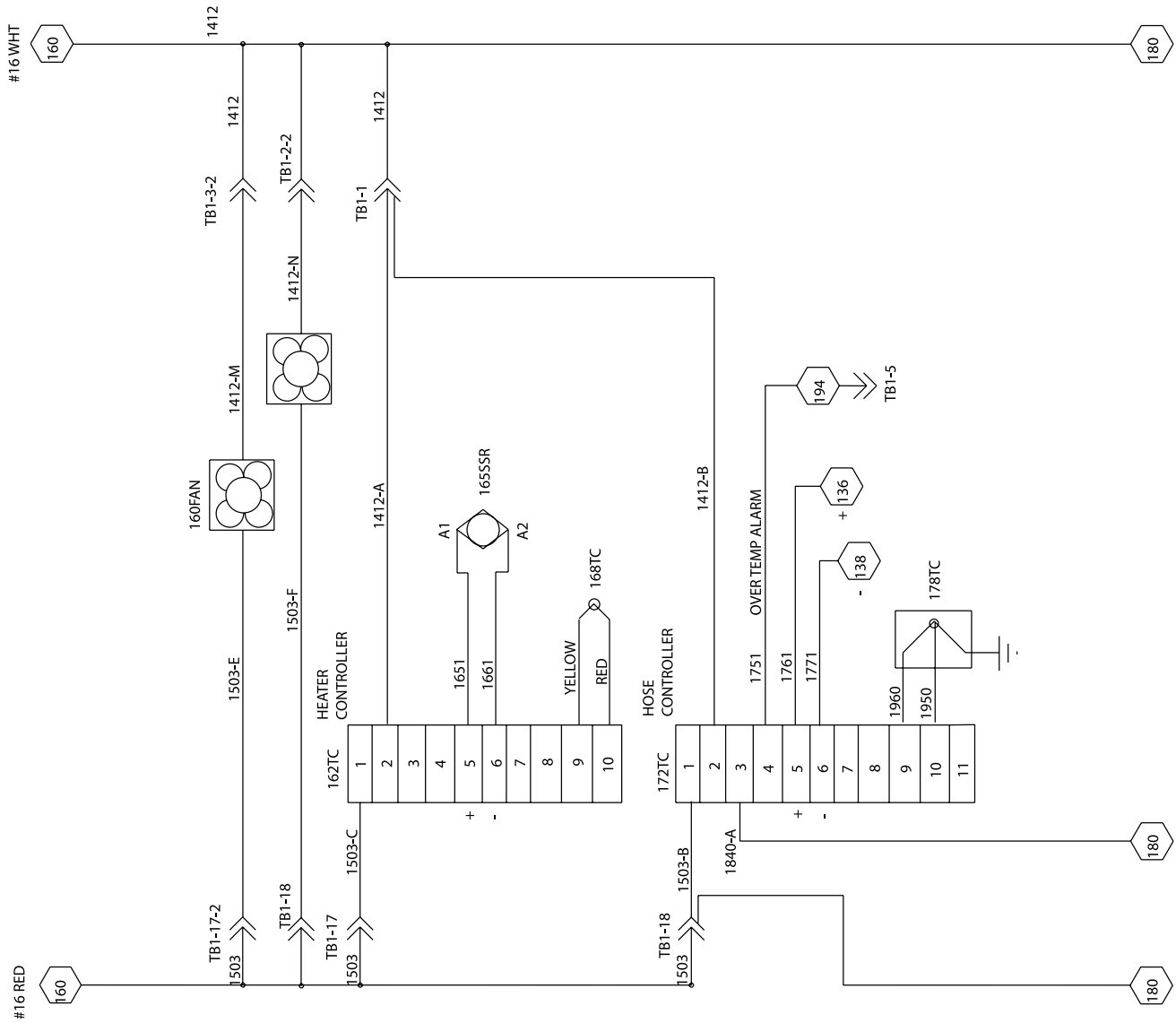

161
162
163
164
165
166
167
168
169
170
171
172
173
174
175
176
177
178
179

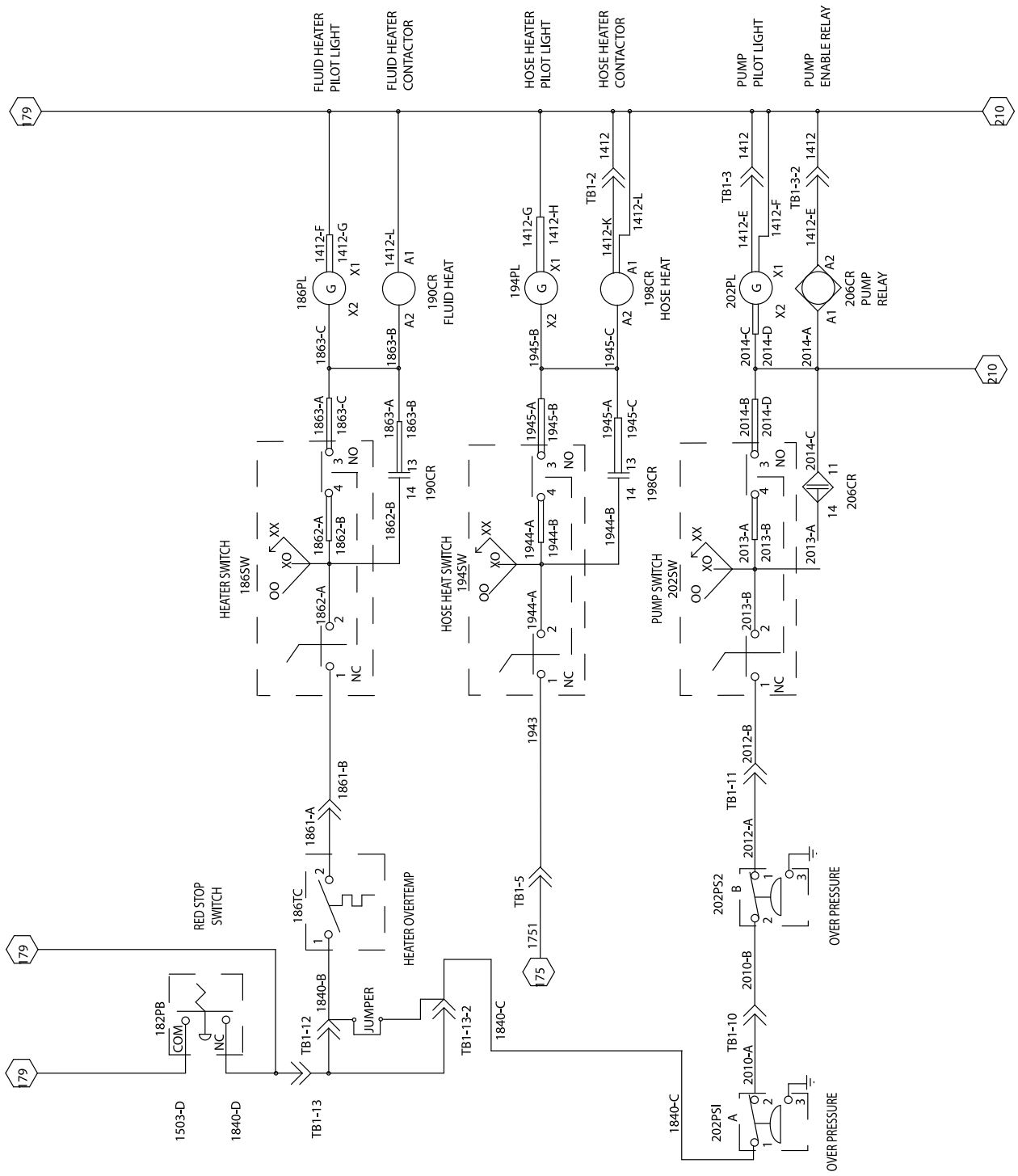

180
181
182
183
184
185
186
187
188
189
190
191
192
193
194
195
196
197
198
199
200
201
202
203
204
205
206
207
208
209

Wiring Diagrams

Heater Circuit

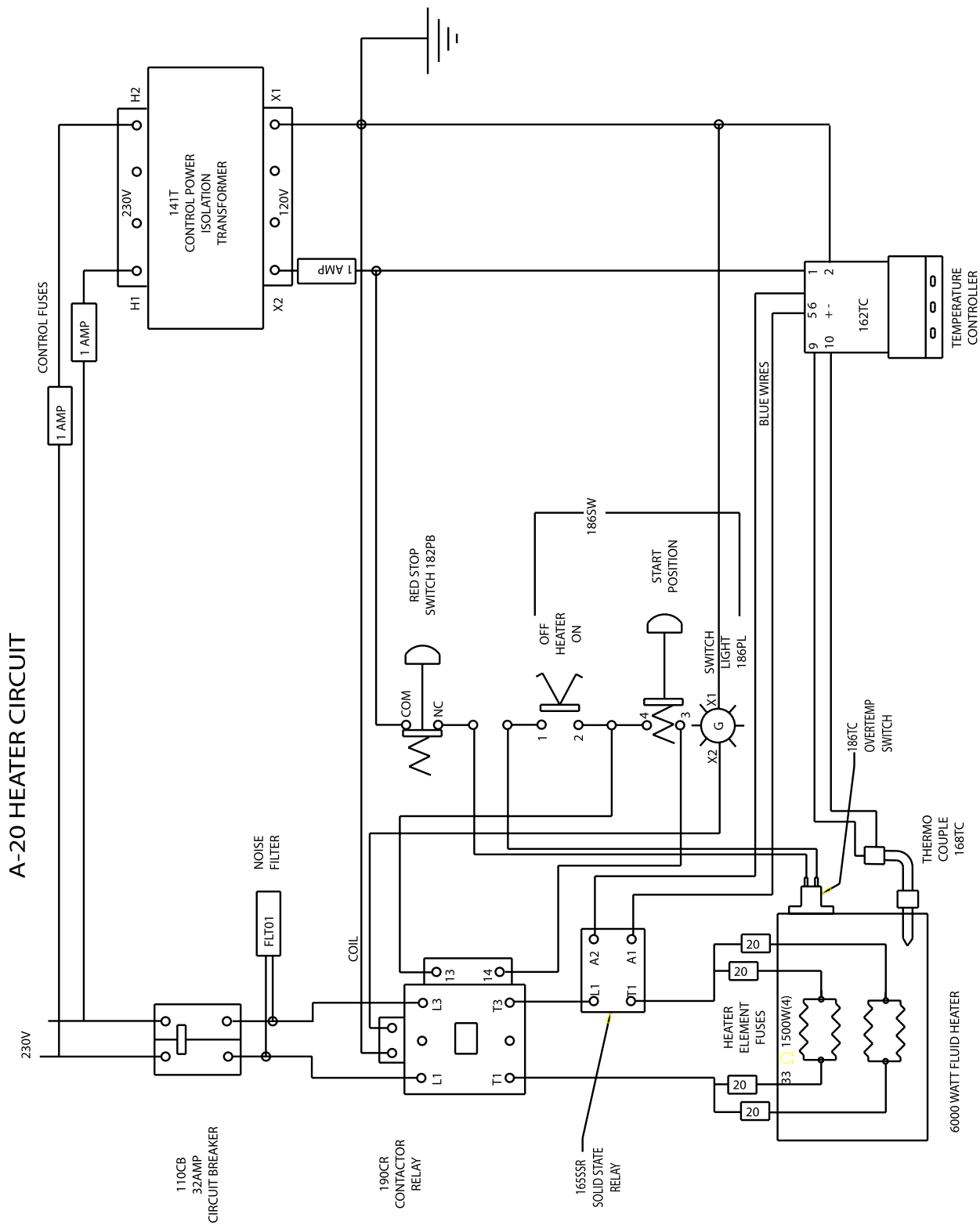

Pump Circuit

A-20 PUMP CIRCUIT

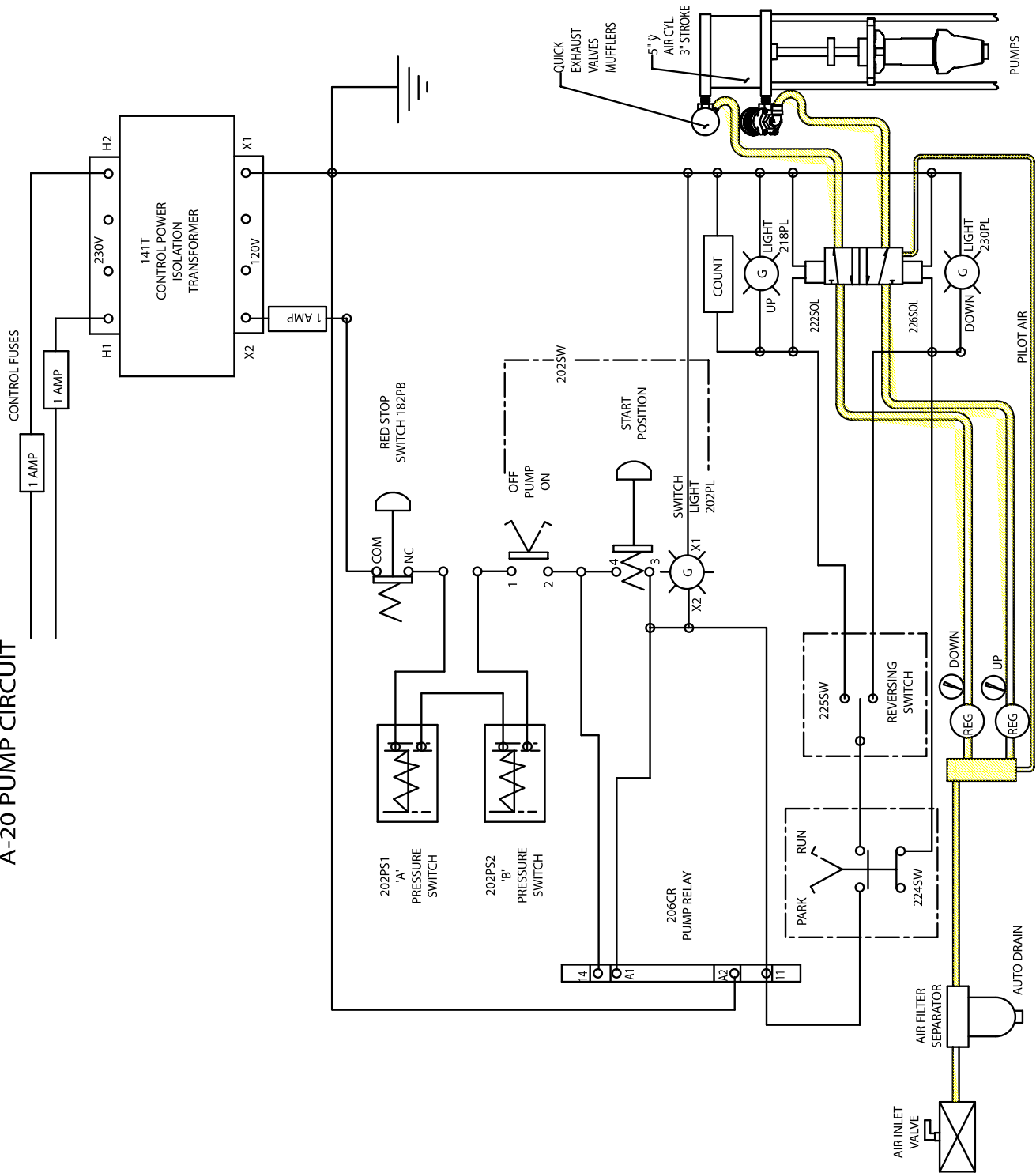

Hose Circuit

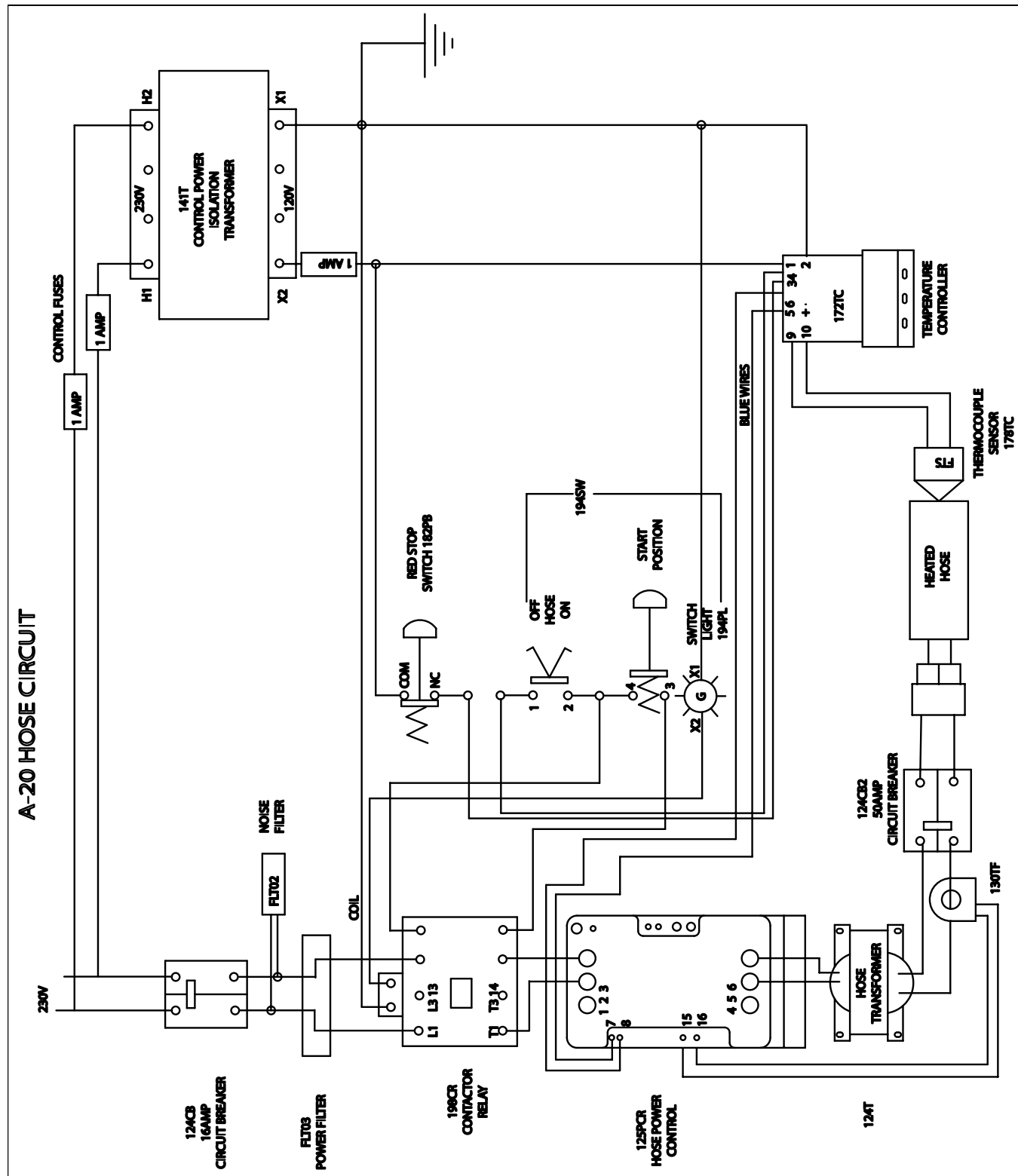

Technical Data

Category	Data
Maximum Fluid Working Pressure	2000 psi (14 MPa, 140 bar)
Maximum Air Working Pressure	120 psi (0.84 MPa, 8.4 bar)
Machine Maximum Power with hose	9000 Watts
Voltage Requirement (50/60 Hz) (230 V Nominal: 195-253 VAC) (380 V Nominal: 338-457 VAC)	230 V, 1 Phase 230 V, 3 Phase (Delta) 380 V, 3 Phase (WYE 220 V Nominal to Neutral)
Amperage Requirement (Full Load Peak)*	40 amps @ 230 V, 1 Phase 32 amps @ 230 V, 3 Phase 18.5 amps @ 380 V, 3 Phase
Maximum Heater Fluid Temperature	190 °F (88 °C)
Maximum Hose Fluid Temperature	180 °F (82 °C)
Maximum Ambient Temperature	120 °F (49 °C)
Maximum Output	20 lb/min. (9.0 kg/min.)
Output Per Cycle (A and B)	0.028 gal/cycle (0.105 ltr/cycle)
Overpressure Relief Shutdown	2250 psi (15.5 MPa, 155 bar)
Over Temperature Shutdown (Primary Heater)	230 °F (110 °C)
Heater Power	6000 Watts
Hose Power	2790 Watts
Sound Pressure	86.3 dB(A) at 2000 psi (14 MPa, 140 bar), 0.5 gpm (1.9 lpm)
Sound Power, per ISO 9614-2	91.6 dB(A) at 2000 psi (14 MPa, 140 bar), 0.5 gpm (1.9 lpm)
Viscosity Range	250-1500 centipoise
Maximum Fluid Inlet Pressure	400 psi (2.7 MPa, 27 bar)
Fluid Inlet/Strainer Filter	20 mesh standard (optional - 60/40 mesh)
Air inlet Filter Mesh	5 Micron
Component B (Resin) Inlet	3/4 npt(f) swivel
Component A (Isocyanate) Inlet	1/2 npt(f) swivel
Recirculation/Block Hose Connections	Iso (A) side: #5 JIC (m); Resin (B) side: #6 JIC (m)
Maximum Heated Hose Length	310 ft. (95 m) 210 ft of 3/8 ID @ 12 watts/ft, 310 ft @ 9 watts/ft
Height	39.5 in. (1003.3 cm)
Width	27.2 in. (690.9 cm)
Depth	25.0 in. (635 cm)
Weight	250 lb (117.6 kg)
Wetted Parts	Carbon steel, stainless steel, chrome, aluminum, Fluoroelastomer, PTFE, nylon
Certification	CE **

*Full load amps with all devices operating at maximum capabilities with 210 ft (64.1 m) of hose.

**When a surge transient is applied to the power lines of the unit, heat to the hose may be interrupted and require the hose heat switch to be manually cycled.

Graco Standard Warranty

Graco warrants all equipment referenced in this document which is manufactured by Graco and bearing its name to be free from defects in material and workmanship on the date of sale to the original purchaser for use. With the exception of any special, extended, or limited warranty published by Graco, Graco will, for a period of twelve months from the date of sale, repair or replace any part of the equipment determined by Graco to be defective. This warranty applies only when the equipment is installed, operated and maintained in accordance with Graco's written recommendations.

This warranty does not cover, and Graco shall not be liable for general wear and tear, or any malfunction, damage or wear caused by faulty installation, misapplication, abrasion, corrosion, inadequate or improper maintenance, negligence, accident, tampering, or substitution of non-Graco component parts. Nor shall Graco be liable for malfunction, damage or wear caused by the incompatibility of Graco equipment with structures, accessories, equipment or materials not supplied by Graco, or the improper design, manufacture, installation, operation or maintenance of structures, accessories, equipment or materials not supplied by Graco.

This warranty is conditioned upon the prepaid return of the equipment claimed to be defective to an authorized Graco distributor for verification of the claimed defect. If the claimed defect is verified, Graco will repair or replace free of charge any defective parts. The equipment will be returned to the original purchaser transportation prepaid. If inspection of the equipment does not disclose any defect in material or workmanship, repairs will be made at a reasonable charge, which charges may include the costs of parts, labor, and transportation.

THIS WARRANTY IS EXCLUSIVE, AND IS IN LIEU OF ANY OTHER WARRANTIES, EXPRESS OR IMPLIED, INCLUDING BUT NOT LIMITED TO WARRANTY OF MERCHANTABILITY OR WARRANTY OF FITNESS FOR A PARTICULAR PURPOSE.

Graco's sole obligation and buyer's sole remedy for any breach of warranty shall be as set forth above. The buyer agrees that no other remedy (including, but not limited to, incidental or consequential damages for lost profits, lost sales, injury to person or property, or any other incidental or consequential loss) shall be available. Any action for breach of warranty must be brought within two (2) years of the date of sale.

GRACO MAKES NO WARRANTY, AND DISCLAIMS ALL IMPLIED WARRANTIES OF MERCHANTABILITY AND FITNESS FOR A PARTICULAR PURPOSE, IN CONNECTION WITH ACCESSORIES, EQUIPMENT, MATERIALS OR COMPONENTS SOLD BUT NOT MANUFACTURED BY GRACO. These items sold, but not manufactured by Graco (such as electric motors, switches, hose, etc.), are subject to the warranty, if any, of their manufacturer. Graco will provide purchaser with reasonable assistance in making any claim for breach of these warranties.

In no event will Graco be liable for indirect, incidental, special or consequential damages resulting from Graco supplying equipment hereunder, or the furnishing, performance, or use of any products or other goods sold hereto, whether due to a breach of contract, breach of warranty, the negligence of Graco, or otherwise.

FOR GRACO CANADA CUSTOMERS

The Parties acknowledge that they have required that the present document, as well as all documents, notices and legal proceedings entered into, given or instituted pursuant hereto or relating directly or indirectly hereto, be drawn up in English. Les parties reconnaissent avoir convenu que la rédaction du présente document sera en Anglais, ainsi que tous documents, avis et procédures judiciaires exécutés, donnés ou intentés, à la suite de ou en rapport, directement ou indirectement, avec les procédures concernées.

Graco Information

TO PLACE AN ORDER, contact your Graco distributor or call to identify the nearest distributor.

Phone: 612-623-6921 **or Toll Free:** 1-800-328-0211 **Fax:** 612-378-3505

*All written and visual data contained in this document reflects the latest product information available at the time of publication.
Graco reserves the right to make changes at any time without notice.*

This manual contains English. MM 311512

Graco Headquarters: Minneapolis
International Offices: Belgium, China, Japan, Korea

GRACO INC. P.O. BOX 1441 MINNEAPOLIS, MN 55440-1441

Copyright 2006, Graco Inc. is registered to I.S. EN ISO 9001

www.graco.com
Revised 8/2008