

REACTOR™

312063G

Hydraulic, Heated, Plural Component Proportioner
For spraying polyurethane foam and polyurea coatings.
Not for use in explosive atmospheres.

U.S. Patent Pending



Important Safety Instructions

Read all warnings and instructions in this manual.
Save these instructions.

See page 3 for model information, including
maximum working pressure and approvals.

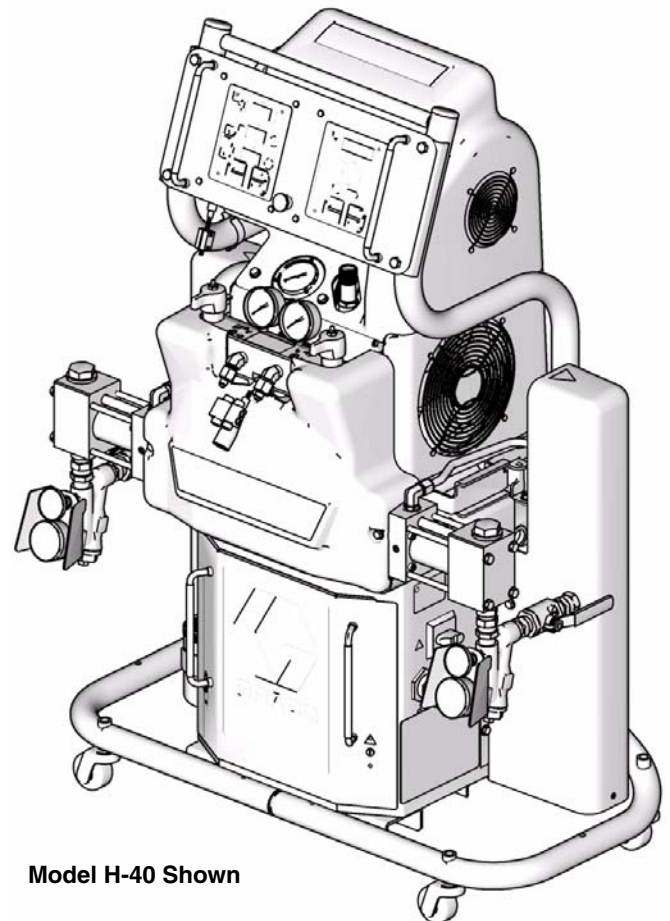

Model H-40 Shown

T19830a



9902471
Conforms to ANSI/UL
Std. 499 Certified to
CAN/CSA Std.
C22.2 No. 88



H003

Contents

Models	3	Repair	27
Supplied Manuals	5	Pressure Relief Procedure	27
Related Manuals	5	Flushing	28
Warnings	6	Proportioning Pumps	28
Temperature Control Diagnostic Codes	8	Circuit Breaker Module	30
E01: High fluid temperature	8	Electric Motor	31
E02: High zone current	9	Motor Control Board	32
E03: No zone current	9	Transducers	34
E04: Fluid Temperature Sensor (FTS) or thermocouple disconnected	9	Electric Fan	34
E05: Circuit board overheated	10	Temperature Control Module	35
E06: Communication cable unplugged	10	Primary Heaters	37
Motor Control Diagnostic Codes	11	Heated Hose	39
Alarms	11	Fluid Temperature Sensor (FTS)	40
Warnings	11	Display Module	42
E21: No component A transducer	12	Inlet Fluid Strainer Screen	44
E22: No component B transducer	12	Pump Lubrication System	44
E23: High fluid pressure	12	Change Hydraulic Fluid and Filter	45
E24: Pressure imbalance	12	Parts	47
E27: High motor temperature	14	Parts Used on All Models	53
E30: Momentary loss of communication	14	Parts that Vary by Model	55
E31: Pumpline reversing switch failure/high cycle rate	14	Sub Assemblies	58
E99: Loss of communication	15	Proportioner Assembly	58
Troubleshooting	16	10.2 kW and 6.0 kW Heaters	60
Reactor Electronics	16	8.0 kW Dual Zone Heater	61
Primary Heaters (A and B)	18	7.65 kW Single Zone Heater	62
Hose Heat System	19	Hydraulic Cylinder	63
Hydraulic Drive System	21	Display	64
Proportioning System	23	Temperature Control	65
		Fluid Manifold	66
		Circuit Breaker Modules	67
		Dimensions	72
		Technical Data	73
		Graco Standard Warranty	74
		Graco Information	74

Models

H-25 SERIES

Part, Series	Full Load Peak Amps* Per Phase	Voltage (phase)	System Watts†	Primary Heater Watts	Max Flow Rate◆ lb/min (kg/min)	Approximate Output per Cycle (A+B) gal. (liter)	Hydraulic Pressure Ratio	Maximum Fluid Working Pressure psi (MPa, bar)
255400, D	69	230V (1)	15,960	8,000	22 (10)	0.063 (0.24)	1.91:1	2000 (13.8, 138)
255401, D	46	230V (3)	15,960	8,000	22 (10)	0.063 (0.24)	1.91:1	2000 (13.8, 138)
255402, D	35	400V (3)	15,960	8,000	22 (10)	0.063 (0.24)	1.91:1	2000 (13.8, 138)
255406, D	100	230V (1)	23,260	15,300	22 (10)	0.063 (0.24)	1.91:1	2000 (13.8, 138)
255407, D	59	230V (3)	23,260	15,300	22 (10)	0.063 (0.24)	1.91:1	2000 (13.8, 138)
255408, D	35	400V (3)	23,260	15,300	22 (10)	0.063 (0.24)	1.91:1	2000 (13.8, 138)

H-40 SERIES

Part, Series	Full Load Peak Amps* Per Phase	Voltage (phase)	System Watts†	Primary Heater Watts	Max Flow Rate◆ lb/min (kg/min)	Approximate Output per Cycle (A+B) gal. (liter)	Hydraulic Pressure Ratio	Maximum Fluid Working Pressure psi (MPa, bar)
★253400, D	100	230V (1)	23,100	12,000	45 (20)	0.063 (0.24)	1.91:1	2000 (13.8, 138)
253401, D	71	230V (3)	26,600	15,300	45 (20)	0.063 (0.24)	1.91:1	2000 (13.8, 138)
253402, D	41	400V (3)	26,600	15,300	45 (20)	0.063 (0.24)	1.91:1	2000 (13.8, 138)
253407, D	95	230V (3)	31,700	20,400	45 (20)	0.063 (0.24)	1.91:1	2000 (13.8, 138)
253408, D	52	400V (3)	31,700	20,400	45 (20)	0.063 (0.24)	1.91:1	2000 (13.8, 138)

H-50 SERIES

Part, Series	Full Load Peak Amps* Per Phase	Voltage (phase)	System Watts†	Primary Heater Watts	Max Flow Rate◆ lb/min (kg/min)	Approximate Output per Cycle (A+B) gal. (liter)	Hydraulic Pressure Ratio	Maximum Fluid Working Pressure psi (MPa, bar)
★253725, D	100	230V (1)	23,100	12,000	52 (24)	0.073 (0.28)	1.64:1	1700 (11.7, 117)
253726, D	71	230V (3)	26,600	15,300	52 (24)	0.073 (0.28)	1.64:1	2000 (13.8, 138)
253727, D	41	400V (3)	26,600	15,300	52 (24)	0.073 (0.28)	1.64:1	2000 (13.8, 138)
256505, D	95	230V (3)	31,700	20,400	52 (24)	0.073 (0.28)	1.64:1	2000 (13.8, 138)
256506, D	52	400V (3)	31,700	20,400	52 (24)	0.073 (0.28)	1.64:1	2000 (13.8, 138)

H-XP2 SERIES

Part, Series	Full Load Peak Amps* Per Phase	Voltage (phase)	System Watts†	Primary Heater Watts	Max Flow Rate◆ gpm (lpm)	Approximate Output per Cycle (A+B) gal. (liter)	Hydraulic Pressure Ratio	Maximum Fluid Working Pressure psi (MPa, bar)
255403, D	100	230V (1)	23,260	15,300	1.5 (5.7)	0.042 (0.16)	2.79:1	3500 (24.1, 241)
255404, D	59	230V (3)	23,260	15,300	1.5 (5.7)	0.042 (0.16)	2.79:1	3500 (24.1, 241)
255405, D	35	400V (3)	23,260	15,300	1.5 (5.7)	0.042 (0.16)	2.79:1	3500 (24.1, 241)

H-XP3 SERIES

Part, Series	Full Load Peak Amps* Per Phase	Voltage (phase)	System Watts†	Primary Heater Watts	Max Flow Rate◆ gpm (lpm)	Approximate Output per Cycle (A+B) gal. (liter)	Hydraulic Pressure Ratio	Maximum Fluid Working Pressure psi (MPa, bar)
★253403, D	100	230V (1)	23,100	12,000	2.8 (10.6)	0.042 (0.16)	2.79:1	3500 (24.1, 241)
253404, D	95	230V (3)	31,700	20,400	2.8 (10.6)	0.042 (0.16)	2.79:1	3500 (24.1, 241)
253405, D	52	400V (3)	31,700	20,400	2.8 (10.6)	0.042 (0.16)	2.79:1	3500 (24.1, 241)

* Full load amps with all devices operating at maximum capabilities. Fuse requirements at various flow rates and mix chamber sizes may be less.

† Total system watts, based on maximum hose length for each unit:

- Parts 255400 through 255408, 310 ft (94.6 m) maximum heated hose length, including whip hose.
- Parts 253400 through 253408, 253725 through 25372, 256505, and 256506, 410 ft (125 m) maximum heated hose length, including whip hose.

◆ Maximum flow rate given for 60 Hz operation. For 50 Hz operation, maximum flow rate is 5/6 of 60 Hz maximum flow.

★ CE approval does not apply.

Supplied Manuals

The following manuals are shipped with the Reactor™ Proportioner. Refer to these manuals for detailed equipment information.

Order Part 15M334 for a compact disk of Reactor manuals translated in several languages.

Manuals are also available at www.graco.com.

Reactor Hydraulic Proportioner	
Part	Description
312062	Reactor Hydraulic Proportioner, Operation Manual (English)
Reactor Electrical Diagrams	
Part	Description
312064	Reactor Hydraulic Proportioner, Electrical Diagrams (English)
Proportioning Pump	
Part	Description
312068	Proportioning Pump Repair-Parts Manual (English)

Translations

The Reactor Repair-Parts manual is available in the following languages. See the following chart for specific languages and corresponding part numbers.

Part	Language
312063	English
312428	Chinese
312429	Dutch
312430	French
312431	German
312432	Italian
312433	Japanese
312434	Korean
312435	Russian
312436	Spanish

Related Manuals





The following manuals are for accessories used with the Reactor™.







Order Part 15M334 for a compact disk of Reactor manuals translated in several languages. Order Part 15B381 for a compact disk of Fusion manual translated in several languages.

Feed Pump Kits	
Part	Description
309815	Instruction-Parts Manual (English)
Air Supply Kit	
Part	Description
309827	Instruction-Parts Manual (English) for Feed Pump Air Supply Kit
Circulation and Return Tube Kits	
Part	Description
309852	Instruction-Parts Manual (English)
Heated Hose	
Part	Description
309572	Instruction-Parts Manual (English)
Circulation Kit	
Part	Description
309818	Instruction-Parts Manual (English)
Circulation Valve Kit	
Part	Description
312070	Instruction-Parts Manual (English)
Data Reporting Kit	
Part	Description
309867	Instruction-Parts Manual (English)
Rupture Disk Assembly Kit	
Part	Description
309969	Instruction-Parts Manual (English)
Proportioning Pump Repair Kits	
Part	Description
312071	Seal Kits Instruction-Parts Manual (English)

Warnings

The following warnings are for the setup, use, grounding, maintenance, and repair of this equipment. The exclamation point symbol alerts you to a general warning and the hazard symbol refers to procedure-specific risk. Refer back to these warnings. Additional, product-specific warnings may be found throughout the body of this manual where applicable.

 WARNING	
	<p>ELECTRIC SHOCK HAZARD</p> <p>Improper grounding, setup, or usage of the system can cause electric shock.</p> <ul style="list-style-type: none"> • Turn off and disconnect power cord before servicing equipment. • Use only grounded electrical outlets. • Use only 3-wire extension cords. • Ensure ground prongs are intact on sprayer and extension cords. • Do not expose to rain. Store indoors.
	<p>TOXIC FLUID OR FUMES HAZARD</p> <p>Toxic fluids or fumes can cause serious injury or death if splashed in the eyes or on skin, inhaled, or swallowed.</p> <ul style="list-style-type: none"> • Read MSDS's to know the specific hazards of the fluids you are using. • Store hazardous fluid in approved containers, and dispose of it according to applicable guidelines. • Always wear impervious gloves when spraying or cleaning equipment.
	<p>PERSONAL PROTECTIVE EQUIPMENT</p> <p>You must wear appropriate protective equipment when operating, servicing, or when in the operating area of the equipment to help protect you from serious injury, including eye injury, inhalation of toxic fumes, burns, and hearing loss. This equipment includes but is not limited to:</p> <ul style="list-style-type: none"> • Protective eyewear • Clothing and respirator as recommended by the fluid and solvent manufacturer • Gloves • Hearing protection
	<p>SKIN INJECTION HAZARD</p> <p>High-pressure fluid from gun, hose leaks, or ruptured components will pierce skin. This may look like just a cut, but it is a serious injury that can result in amputation. Get immediate surgical treatment.</p> <ul style="list-style-type: none"> • Do not point gun at anyone or at any part of the body. • Do not put your hand over the spray tip. • Do not stop or deflect leaks with your hand, body, glove, or rag. • Do not spray without tip guard and trigger guard installed. • Engage trigger lock when not spraying. • Follow Pressure Relief Procedure in this manual, when you stop spraying and before cleaning, checking, or servicing equipment.

 WARNING	
	<p>FIRE AND EXPLOSION HAZARD</p> <p>Flammable fumes, such as solvent and paint fumes, in work area can ignite or explode. To help prevent fire and explosion:</p> <ul style="list-style-type: none"> • Use and clean equipment only in well ventilated area. • Eliminate all ignition sources; such as pilot lights, cigarettes, portable electric lamps, and plastic drop cloths (potential static arc). • Keep work area free of debris, including solvent, rags and gasoline. • Do not plug or unplug power cords or turn lights on or off when flammable fumes are present. • Ground equipment, personnel, object being sprayed, and conductive objects in work area. See Grounding instructions. • Use only Graco grounded hoses. • Check gun resistance daily. • If there is static sparking or you feel a shock, stop operation immediately. Do not use equipment until you identify and correct the problem. • Do not flush with gun electrostatics on. Do not turn on electrostatics until all solvent is removed from system. • Keep a working fire extinguisher in the work area.
	<p>PRESSURIZED ALUMINUM PARTS HAZARD</p> <p>Do not use 1,1,1-trichloroethane, methylene chloride, other halogenated hydrocarbon solvents or fluids containing such solvents in pressurized aluminum equipment. Such use can cause serious chemical reaction and equipment rupture, and result in death, serious injury, and property damage.</p>
	<p>EQUIPMENT MISUSE HAZARD</p> <p>Misuse can cause death or serious injury.</p> <ul style="list-style-type: none"> • This equipment is for professional use only. • Do not leave the work area while the equipment is energized or under pressure. Turn off all equipment and follow the Pressure Relief Procedure in this manual when the equipment is not in use. • Do not operate the unit when fatigued or under the influence of drugs or alcohol. • Do not exceed the maximum working pressure or temperature rating of the lowest rated system component. See Technical Data in all equipment manuals. • Use fluids and solvents that are compatible with equipment wetted parts. See Technical Data in all equipment manuals. Read fluid and solvent manufacturer's warnings. For complete information about your material, request MSDS forms from distributor or retailer. • Check equipment daily. Repair or replace worn or damaged parts immediately with genuine manufacturer's replacement parts only. • Do not alter or modify equipment. • Use equipment only for its intended purpose. Call your distributor for information. • Route hoses and cables away from traffic areas, sharp edges, moving parts, and hot surfaces. • Do not kink or over bend hoses or use hoses to pull equipment. • Keep children and animals away from work area. • Comply with all applicable safety regulations.
	<p>MOVING PARTS HAZARD</p> <p>Moving parts can pinch or amputate fingers and other body parts.</p> <ul style="list-style-type: none"> • Keep clear of moving parts. • Do not operate equipment with protective guards or covers removed. • Pressurized equipment can start without warning. Before checking, moving, or servicing equipment, follow the Pressure Relief Procedure in this manual. Disconnect power or air supply.
	<p>BURN HAZARD</p> <p>Equipment surfaces and fluid that's heated can become very hot during operation. To avoid severe burns, do not touch hot fluid or equipment. Wait until equipment/fluid has cooled completely.</p>

Temperature Control Diagnostic Codes

Temperature control diagnostic codes appear on temperature display.

These alarms turn off heat. E99 clears automatically when communication is regained. Codes E03 through

E06 can be cleared by pressing . For other codes,

turn main power OFF  then ON  to clear.

Code	Code Name	Alarm Zone	Corrective Action page
01	High fluid temperature	Individual	8
02	High zone current	Individual	9
03	No zone current with hose heater on	Individual	9
04	FTS not connected	Individual	9
05	Board overtemperature	Individual	10
06	Communication cable unplugged from module	Individual	10
99	Loss of communication	A	15





For hose zone only, if FTS is disconnected at startup, display will show hose current 0A.

E01: High fluid temperature

Causes of E01 Errors

- Thermocouple A or B (310) senses a fluid temperature above 230°F (110°C).
- Fluid temperature sensor (FTS) senses a fluid temperature above 230°F (110°C).
- Overtemperature switch A or B (308) senses a fluid temperature above 230°F (110°C) and opens. At 190°F (87°C) the switch closes again.
- Thermocouple A or B (310) fails, is damaged, is not touching the heater element (307), or has a poor connection to the temperature control board.
- Overtemperature switch A or B (308) fails in the open position.
- The temperature control board fails to turn off any heat zone.
- Zone power wires or thermocouples are switched from one zone to another.
- Failed heater element where thermocouple is installed.

Checks

						
<p>Troubleshooting this equipment requires access to parts that may cause electric shock or other serious injury if work is not performed properly. Have a qualified electrician perform all electrical troubleshooting. Be sure to shut off all power to the equipment before repairing.</p>						

Check which zone is displaying the E01 error.

1. Check that connector A is firmly plugged into temperature control module (see FIG. 8, page 35).
2. Clean and re-plug connections.
3. Check connections between the temperature control module and overtemperature switches A and B (308), and between temperature control module and thermocouples A and B (310) or FTS (21) [depending on which zone is displaying E01]. See TABLE 6, page 35. Ensure that all wires are securely connected to connector B.

4. Remove connector B from temperature control module, and check continuity of overtemperature switches A and B, thermocouples A and B, or FTS by measuring resistance across the pins on the plug end; see TABLE 1.

 Before doing the following checks, note which zone (A, B, FTS, or all) has high fluid temperature.

Table 1: Sensor Connector Continuity Checks

Pins	Description	Reading
1 & 2	OT switch A	nearly 0 ohms
3 & 4	OT switch B	nearly 0 ohms
5 & 6	Thermocouple A	4-6 ohms
8 & 9	Thermocouple B	4-6 ohms
11 & 12	FTS	approximately 35 ohms per 50 ft (15.2 m) of hose, plus approximately 10 ohms for FTS
10 & 12	FTS	100k ohms

5. Verify fluid temperature, using an external temperature sensing device.
 - **If temperature *is* too high (sensor reading is 229°F [109°C] or above):**
6. Check if thermocouples A and B are damaged, or not contacting the heater element, page 38.
7. To test that temperature control module turns off when equipment reaches temperature setpoint:
 - a. Set temperature setpoints far below displayed temperature.
 - b. Turn zone on. If temperature rises steadily, power board is failing.
 - c. Verify by swapping with another power module. See **Replacing Temperature Control Assembly Modules**, page 36.
 - d. If the swapped module does not fix the problem, the power module is not the cause.
8. Verify continuity of heater elements with an ohmmeter, see page 36.

E02: High zone current

1. Check connections for electrical short, page 39.
2. Exchange zone module with another one. Turn zone on and check for error (see page 36). If error disappears, replace faulty module.
 - a. *For hose zone:* If error still occurs, perform **Transformer Primary Check** and **Transformer Secondary Check**, starting on page 41.

 When there is a high current error, the LED on that zone's module will turn red while the error is displayed.

E03: No zone current

1. Check for tripped circuit breaker inside electrical cabinet or at power source for that zone. Replace circuit breaker if it trips habitually.
2. Check for loose or broken connection at that zone.
3. Exchange zone module with another one. Turn zone on and check for error (see page 36). If error disappears, replace faulty module.
4. If E03 occurs for all zones, the contactor may not be closing. Verify wiring from heater control to contactor coil.
 - a. *Hose zone:* test hose continuity, page 39.
 - b. Perform **Transformer Primary Check** and **Transformer Secondary Check**, starting on page 41.

 When a no current error occurs, the LED on the specific zone's module turns red when the error is displayed.

E04: Fluid Temperature Sensor (FTS) or thermocouple disconnected

1. Check temperature sensor connections to long green connector on temperature control module, page 35. Unplug and re-plug sensor wires.
2. Test fluid temperature sensor continuity with ohmmeter, page 8.

3. If an error occurred for the hose zone, check FTS connections at each section of hose.
4. If an error occurred for the hose zone, test FTS by plugging directly into machine.

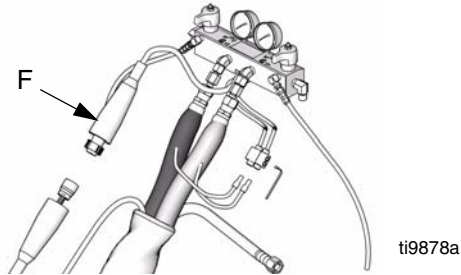

5. To verify heater control module is not causing the problem, use a wire to short-circuit the two pins corresponding to the FTS (red and yellow for A or B zone, red and purple for hose). The display will show the control heater module temperature.
6. If an error occurred for the hose zone, temporarily use the current control mode. Refer to Reactor Operation manual 312062.

E05: Circuit board overheated

 Each module has an on-board temperature sensor. Heat is turned off if module temperature exceeds 185°F (85°C) within the heater module.

1. Check that fan above electrical cabinet is operating.
2. Check that electrical cabinet door is properly installed.
3. Check for obstructions blocking cooling holes in bottom of electrical cabinet.
4. Clean heatsink fins behind heater control modules.
5. Ambient temperature may be too high. Allow Reactor to cool by moving to a cooler location.

E06: Communication cable unplugged

1. Unplug and re-plug cable that connects heater control module to heater module.
2. Replace communication cable if problem persists.

Motor Control Diagnostic Codes

Motor control diagnostic codes E21 through E27 appear on pressure display.

There are two types of motor control codes: alarms and warnings. Alarms take priority over warnings.

Alarms

Alarms turn off Reactor. Turn main power OFF

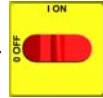

then ON



to clear.



Alarms can also be cleared, except for code 23, by

pressing .

Warnings

Reactor will continue to run. Press to clear. A

warning will not recur for a predetermined amount of time (varies for different warnings), or until main power

is turned OFF



then ON



.

Code	Code Name	Alarm (A) or Warning (W)	Corrective Action page
21	No transducer (component A)	A	12
22	No transducer (component B)	A	12
23	High fluid pressure	A	12
24	Pressure imbalance	A/W (to select, see page 32)	12
27	High motor temperature	A	14
30	Momentary loss of communication	A	14
31	Pipeline reversing switch failure/high cycle rate	A	14
99	Loss of communication	A	15

E21: No component A transducer

1. Check transducer A connection at J3 on motor control board, page 33, and clean contacts.
2. Reverse A and B transducer connections. If error moves to transducer B (E22), replace transducer A, page 34. If error does not move, replace motor control board, page 32.

E22: No component B transducer

1. Check transducer B connection at J8 on motor control board, page 33, and clean contacts.
2. Reverse A and B transducer connections. If error moves to transducer A (E21), replace transducer B, page 34. If error does not move, replace motor control board, page 32.

E23: High fluid pressure

1. Relieve pressure. Verify low pressure with analog

gauges. Turn main power OFF  then ON

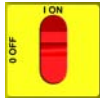



. If error persists, do checks below.

2. If pressure imbalance is set to Warning instead of Alarm (see page 32), an E23 will occur. See **E24: Pressure imbalance** for causes and checks.

E24: Pressure imbalance

 Upon initial start-up this diagnostic code will not cause an alarm for 2 minutes.

 If the pressure difference between components A and B exceeds 500 psi (3.5 MPa, 35 bar), an E24 will occur. This default value is adjustable; see the operation manual.

 E24 can be an alarm or a warning, as desired. Set DIP switch on motor control board ON for alarm, OFF for warning. See page 32.

Fast E24 Errors

Fast E24 errors occur:

- within 10 seconds of turning the pumps on, or
- as soon as you trigger the gun.

Causes of Fast E24 Errors

- one side of the gun is plugged.
- a pressure transducer has failed.
- damaged pump seals or check valve.
- no feed pressure or empty material drum
- plugged heater.
- plugged hose.
- plugged manifold.
- one PRESSURE RELIEF/SPRAY valve is leaking or

is set to PRESSURE RELIEF/CIRCULATION .

Checks for Fast E24 Errors

 If a fast E24 error occurs, first check the readings of the analog gauges.

- **If the gauge readings are very close:**

1. Clear the error (page 11) and try running the unit again.
2. If E24 recurs and the gauge readings are still very close, a pressure transducer has failed.

The digital display always shows the higher of the two pressures. As soon as the higher analog pressure drops below the lower analog pressure, the display changes to the new higher reading. Knowing this, the following checks will show which transducer has failed, or if the motor control board has failed.

3. For testing purposes only, set DIP switch 2 on the motor control board to OFF. See page 32. This will allow the Reactor to continue to run with a pressure imbalance.
 - c. Run the unit until pressure is 1000-1500 psi (7-10.5 MPa, 70-105 bar). Shut down the unit, clear the alarm, and power back up, but do not depressurize the unit.
 - d. Check the analog gauges to see which pressure is higher, and check if the display matches.

If the higher gauge and display match, that transducer is communicating with the motor control board. Continue with step e.

If the higher gauge and display do not match, that transducer is not communicating with the motor control board. Check wire connections and replace transducer, page 34.

- e. Turn pumps off. Reduce pressure of higher component by **slightly** turning PRESSURE RELIEF/SPRAY valve for that component toward

PRESSURE RELIEF/CIRCULATION , while watching the display and the analog gauges. As soon as the higher analog pressure drops below the lower analog pressure, the display should change to the new higher reading. Continue reducing the original higher pressure an additional 200 psi (1.4 MPa, 14 bar); digital display should stop dropping.

- f. Repeat for the other side, to check the other transducer.

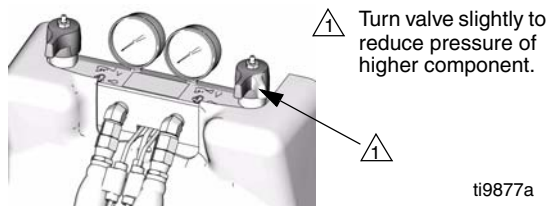

4. To test if the failure is with the transducer or the socket on the motor control board:

- a. Reverse connections at J3 and J8 on the motor control board.
- b. Run the unit until pressure is 1000-1500 psi (7-10.5 MPa, 70-105 bar).
- c. If the problem stays on the same side as before, replace the motor control board. If the problem appears to move to the other side, replace the transducer.

• **If the gauge readings are not very close:**

1. Secure bleed lines in grounded waste containers, or route back to respective component A or B supply drum. Reduce pressure of higher component by **slightly** turning PRESSURE RELIEF/SPRAY valve for that component toward PRESSURE

RELIEF/CIRCULATION , until gauges show balanced pressures.

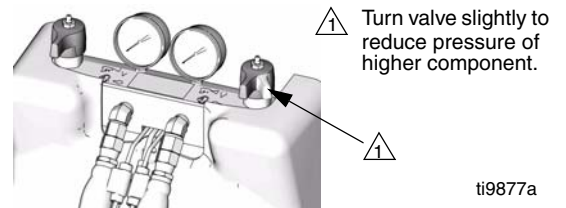

 Turn PRESSURE RELIEF/SPRAY valve only enough to balance pressure. If you turn it completely, all pressure will bleed off.

2. If you cannot get the pressures to balance:
 - a. Check for damaged pump seals or check valves.
 - b. Check if you've run out of material.
 - c. Check for a plugged fluid path by using the feed pump to push fluid through the gun manifold.
3. If you are able to balance pressures, try running the unit.

4. If a fast E24 error occurs again, and the gauges readings are not very close:
 - a. Check and clean the gun inlet screens.
 - b. Check and clean the gun mix chamber impingement ports and center port. See gun manual.

 Some mix chambers have counter bored impingement ports, requiring two drill sizes to clean completely.

Slow E24 Errors

Slow E24 errors occur gradually. The pressures are balanced when you begin spraying, but slowly become imbalanced until an E24 occurs.

Causes of Slow E24 Errors

- one side of the gun is partially plugged.
- the A or B proportioner pump has failed.
- the A or B feed pump has failed.
- the A or B feed pump pressure is set too high.
- the A or B proportioner pump inlet screen is plugged.
- the hose is not heating properly.
- kinked supply hose.
- bottom of drum is damaged, causing blockage of feed pump inlet.
- drum is not vented.

E27: High motor temperature

Causes of E27 Errors

- Motor temperature is too high. Reduce pressure, gun tip size, or move Reactor to a cooler location. Allow 1 hour for cooling.
- Make sure there is no obstruction to fan airflow. Ensure that the motor/fan shroud is installed.
- Check that the motor overtemperature wire assembly is plugged into J9 on the motor control board, page 33.
- If the preceding checks do not correct the problem, perform the following tests:

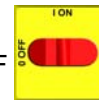

1. Turn main power OFF.
2. Allow motor to cool completely. Check continuity between pins 1 and 2 on connector J9 on the motor control board, page 32. If the resistance is infinity, the motor thermal switch or the wire harness is bad. Check wiring, measure thermal switch continuity at motor, and replace failed part.
3. Unplug motor from J9 on motor control board. Install jumper across pins 1 and 2 on board. If error still occurs, replace motor control board.
4. If the E27 error is still occurring, the problem is with the motor control board.

E30: Momentary loss of communication

If communication is lost between the display and the motor control board, the display will normally show E99. The motor control board will register E30 (the red LED will blink 30 times). When communications are reconnected, the display may show E30 briefly (no more than 2 seconds). If the display shows E30 continuously, there is a loose connection causing the display and board to repeatedly lose and regain communication.

E31: Pumpline reversing switch failure/high cycle rate

Failure of a pumpline switch or switch mechanism may result in a high cycle rate, causing an E31 to occur. Replace the switch or switch mechanism. See **Pumps Do Not Reverse Direction**, page 26.

E31 may also occur if the system is modified to produce a higher flow rate.

E99: Loss of communication

If communication is lost between the motor control display and the motor control board, or the temperature control display and the temperature control module, the affected display will show E99.

1. Check all wiring between the display and the motor control board and the temperature control module. Pay close attention to the wire crimping at J13 on the motor control board (page 33) and (C) on the temperature control module (page 35). Unplug and re-plug connectors.
 2. Incoming voltage should be 230 Vac. Check the temperature control module voltage at terminal block (805) on the circuit breaker module (see page 67). Check the motor control board voltage at motor/pumps circuit breaker (813), see page 30.
- **Check if temperature control module or motor control board is causing error:**
3. Swap display connection on temperature control module (C) with display connection on motor control board (J13).
 4. If error no longer occurs, the board or module was at fault. Switch connections back to ensure connector was not poorly connected.

Troubleshooting

Reactor Electronics



2. Turn main power OFF



3. Allow equipment to cool.

Before performing any troubleshooting procedures:

1. Relieve pressure, page 27.

Try the recommended solutions in the order given for each problem, to avoid unnecessary repairs. Also, determine that all circuit breakers, switches, and controls are properly set and wiring is correct before assuming there is a problem.

PROBLEM	CAUSE	SOLUTION
Both sides of display do not illuminate.	No power.	Plug in power cord. Turn disconnect ON 
	Low voltage.	Ensure input voltage is within specifications, page 42.
	Loose wire.	Check connections, page 42.
	Display disconnected.	Check cable connections, page 42.
Temperature display does not illuminate.	Display disconnected.	Check cable connections, page 42.
	Display cable damaged or corroded.	Clean connections; replace cable if is damaged.
	Defective circuit board.	Swap display connection to motor control board with connection to heater control board. If temperature display illuminates, heater control board is causing problem. Otherwise, display cable or display is failing.
Pressure display does not illuminate.	Display disconnected.	Check cable connections, page 42.
	Display cable damaged or corroded.	Clean connections; replace cable if is damaged.
	Defective circuit board.	Swap display connection to motor control board with connection to heater control board. If pressure display illuminates, motor control board is causing problem. Otherwise, display cable or display is failing.
Erratic display; display turns on and off.	Low voltage.	Ensure input voltage is within specifications, page 42.
	Poor display connection.	Check cable connections, page 42. Replace damaged cable.
	Display cable damaged or corroded.	Clean connections; replace cable if is damaged.
	Display cable not grounded.	Ground cable, page 42.
	Display extension cable too long.	Must not exceed 100 ft (30.5 m)

PROBLEM	CAUSE	SOLUTION
Hose display reads OA at startup.	FTS disconnected or not installed.	Verify proper installation of FTS (see Operation manual 312062), or adjust FTS to desired current setting.
Display does not respond properly to button pushes.	Poor display connection.	Check cable connections, page 42. Replace damaged cable.
	Display cable damaged or corroded.	Clean connections; replace cable if is damaged.
	Ribbon cable on display circuit board disconnected or broken.	Connect cable (page 42) or replace.
	Broken display button.	Replace, page 42.
Red stop button does not work.	Broken button (fused contact).	Replace, page 42.
	Loose wire.	Check connections, page 42.
Fan not working.	Blown fuse.	Verify with ohmmeter; replace if necessary (page 42).
	Loose wire.	Check fan wire.
	Defective fan.	Replace, page 42.

Primary Heaters (A and B)



Before performing any troubleshooting procedures:

1. Relieve pressure, page 27.

2. Turn main power OFF



3. Allow equipment to cool.

Try the recommended solutions in the order given for each problem, to avoid unnecessary repairs. Also, determine that all circuit breakers, switches, and controls are properly set and wiring is correct before assuming there is a problem.

PROBLEM	CAUSE	SOLUTION
Primary heater(s) does not heat.	Heat turned off.	Press A or B zone I keys.
	Temperature control alarm.	Check temperature display for diagnostic code, page 8.
	Signal failure from thermocouple.	See E04: Fluid Temperature Sensor (FTS) or thermocouple disconnected , page 9.
Control of primary heat is abnormal; high temperature overshoots or E01 error occurs intermittently.	Dirty thermocouple connections.	Examine connection of thermocouples to long green plug on heater control board. Unplug and re-plug thermocouple wires, cleaning off any debris. Unplug and re-plug long green connector.
	Thermocouple not contacting heater element.	Loosen ferrule nut (N), push in thermocouple (310) so tip (T) contacts heater element (307). Holding thermocouple tip (T) against heater element, tighten ferrule nut (N) 1/4 turn past tight. See page 38 for illustration.
	Failed heater element.	See Primary Heaters, page 37.
	Signal failure from thermocouple.	See E04: Fluid Temperature Sensor (FTS) or thermocouple disconnected , page 9.
	Thermocouple wired incorrectly.	See E04: Fluid Temperature Sensor (FTS) or thermocouple disconnected , page 9. Power up zones one at a time and verify that temperature for each zone rises.

Hose Heat System



Before performing any troubleshooting procedures:

1. Relieve pressure, page 27.

2. Turn main power OFF

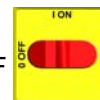

3. Allow equipment to cool.

Problems

Try the recommended solutions in the order given for each problem, to avoid unnecessary repairs. Also, determine that all circuit breakers, switches, and controls are properly set and wiring is correct before assuming there is a problem.

PROBLEM	CAUSE	SOLUTION
Hose heats but heats slower than usual or it does not reach temperature.	Ambient temperature is too cold.	Use auxiliary hose heat system.
	FTS failed or not installed correctly.	Check FTS, page 9.
	Low supply voltage.	Verify line voltage. Low line voltage significantly reduces power available to hose heat system, affecting longer hose lengths.
Hose does not maintain temperature while spraying.	A and B setpoints too low.	Increase A and B setpoints. Hose is designed to maintain temperature, not to increase it.
	Ambient temperature is too cold.	Increase A and B setpoints to increase fluid temperature and keep it steady.
	Flow too high.	Use smaller mix chamber. Decrease pressure.
	Hose was not fully preheated.	Wait for hose to heat to correct temperature before spraying.
	Low supply voltage.	Verify line voltage. Low line voltage significantly reduces power available to hose heat system, affecting longer hose lengths.
Hose temperature exceeds setpoint.	A and/or B heaters are overheating material.	Check primary heaters for either a thermocouple problem or a failed element attached to thermocouple, page 9.
	Faulty thermocouple connections.	Verify that all FTS connections are snug and that pins of connectors are clean. Examine connection of thermocouples to long green plug on heater control board. Unplug and re-plug thermocouple wires, cleaning off any debris. Unplug and re-plug long green connector on heater control board.

PROBLEM	CAUSE	SOLUTION
Erratic hose temperature.	Faulty thermocouple connections.	Verify that all FTS connections are snug and that pins of connectors are clean. Examine connection of thermocouples to long green plug on heater control board. Unplug and re-plug thermocouple wires, cleaning off any debris. Unplug and re-plug long green connector.
	FTS not installed correctly.	FTS should be installed close to end of hose in same environment as gun. Verify FTS installation, page 40.
Hose does not heat.	FTS failed or is not contacting correctly.	Check FTS, page 40.
	FTS not installed correctly.	FTS should be installed close to end of hose in same environment as gun. Verify FTS installation, page 40.
	Temperature control alarm.	Check temperature display or diagnostic code, page 40.
Hoses near Reactor are warm, but hoses downstream are cold.	Shorted connection or failed hose heating element.	<p>With hose heat on and temperature setpoint above displayed hose zone temperature, verify voltage between connectors at each section of hose.</p> <p>Voltage should drop incrementally for each section of hose further from Reactor. Use safety precautions when hose heat is turned on.</p>

Hydraulic Drive System



Before performing any troubleshooting procedures:

1. Relieve pressure, page 27.

2. Turn main power OFF



3. Allow equipment to cool.

Problems

Try the recommended solutions in the order given for each problem, to avoid unnecessary repairs. Also, determine that all circuit breakers, switches, and controls are properly set and wiring is correct before assuming there is a problem.

PROBLEM	CAUSE	SOLUTION
Electric motor will not start or stops during operation.	Loose connections.	Check connections at motor control board.
	Circuit breaker tripped.	Reset breaker (813); see Circuit Breaker Module , page 30. Check 230 Vac at output of breaker.
	Damaged motor control board.	Replace board. See Motor Control Board , page 32.

PROBLEM	CAUSE	SOLUTION
<p>Hydraulic pump does not develop pressure. Low or zero pressure with screeching noise.</p>	<p>Pump is not primed or lost its prime.</p>	<p>Check electric motor rotation. Both motor and hydraulic pump must rotate counterclockwise when viewed from shaft end. If rotation is incorrect, reverse leads L1 and L2. See Connect Electrical Cord in Operation manual 312602.</p>
		<p>Check dipstick to ensure that hydraulic reservoir is properly filled (see Operation manual).</p>
		<p>Check that inlet fitting is fully tight, to ensure no air is leaking into the pump inlet.</p>
		<p>To prime pump, run unit at lowest pressure setting and slowly increase pressure. In some cases it may be necessary to remove motor cover and drive belt to allow for manual (counterclockwise) rotation of hydraulic pump. Turn fan pulley by hand. Verify oil flow by removing oil filter to see flow into filter manifold. Reinstall oil filter. Do NOT operate unit without a properly installed oil filter.</p>
	<p>Screeching noise is characteristic of cavitation and is normal at initial startup for a maximum of 30 seconds.</p>	<p>If noise continues longer than 30 seconds, press motor  key to shut off the motor. Check that the inlet fittings are tight and that the pump has not lost its prime.</p>
<p>Hydraulic fluid is too hot.</p>	<p>Ensure that the reservoir is properly serviced. Improve ventilation to allow more efficient heat dissipation.</p>	
<p>Electric motor operating in wrong direction for 3 Phase system.</p>	<p>Motor must operate counter-clockwise from pully end.</p>	
<p>Drive belt loose or broken.</p>	<p>Check drive belt condition. Replace if broken.</p>	

Proportioning System



Before performing any troubleshooting procedures:

1. Relieve pressure, page 27.

2. Turn main power OFF



3. Allow equipment to cool.

Problems

Try the recommended solutions in the order given for each problem, to avoid unnecessary repairs. Also, determine that all circuit breakers, switches, and controls are properly set and wiring is correct before assuming there is a problem.

PROBLEM	CAUSE	SOLUTION
Proportioning pump does not hold pressure when stalled.	Pump piston or intake valve leaking.	<ol style="list-style-type: none"> 1. Observe gauges to determine which pump is losing pressure. 2. Determine in which direction the pump has stalled by observing which directional valve indicator light is on. See Table 2, page 25 to isolate the problem. 3. Repair the valve; see pump manual 312068.
Material imbalance. See Pressure/Material Imbalance , page 25.	Restriction at the gun.	Clean the gun; see your separate gun manual.
	Inadequate flow from pump; cavitation.	Increase fluid supply to proportioning pump: <ul style="list-style-type: none"> • Use 2:1 supply pump • Use minimum 3/4 in. (19 mm) ID supply hose, as short as practical
		Fluid is too thick. Consult your material supplier for the recommended fluid temperature to maintain a viscosity of 250 to 1500 centipoise.
		Clean inlet strainer screen, page 44.
Worn pump inlet valve ball/seat or gasket. Replace, see pump manual 312068.		
Pressure relief/circulation valve leaking back to supply.	Remove return line and determine if flow is present while in SPRAY  mode.	

PROBLEM	CAUSE	SOLUTION
Pumps do not reverse direction or pumps do not move.	Bent or loose activator plate, rocker arm, or reversing switch.	See Pumps Do Not Reverse Direction , page 26.
	Loose piston packing bolt.	See Pumps Do Not Reverse Direction , page 26.
	Faulty directional valve.	See Pumps Do Not Reverse Direction , page 26.
Erratic pump movement.	Pump cavitation.	Feed pump pressure is too low. Adjust pressure to maintain 100 psi (0.7 MPa, 7 bar) minimum.
		Fluid is too thick. Consult your material supplier for recommended fluid temperature to maintain a viscosity of 250 to 1500 centipoise.
	Loose activator plate, rocker arm, or reversing switch.	See Pumps Do Not Reverse Direction , page 26.
	Faulty directional valve.	Replace directional valve.
Pump output low.	Obstructed fluid hose or gun; fluid hose ID too small.	Open, clear; use hose with larger ID.
	Worn piston valve or intake valve in displacement pump.	See pump manual 312068.
	Inadequate feed pump pressure.	Check feed pump pressure and adjust to 100 psi (0.7 MPa, 7 bar) minimum.
Fluid leak at pump rod seal.	Worn throat seals.	Replace. See pump manual 312068.
No pressure on one side.	Fluid leaking from pump outlet rupture disk (216).	Check if heater (2) and PRESSURE RELIEF/SPRAY valve (SA or SB) are plugged. Clear. Replace rupture disk (216) with a new one; do not replace with a pipe plug.
	Inadequate feed pump pressure.	Check feed pump pressure and adjust to 100 psi (0.7 MPa, 7 bar) minimum.

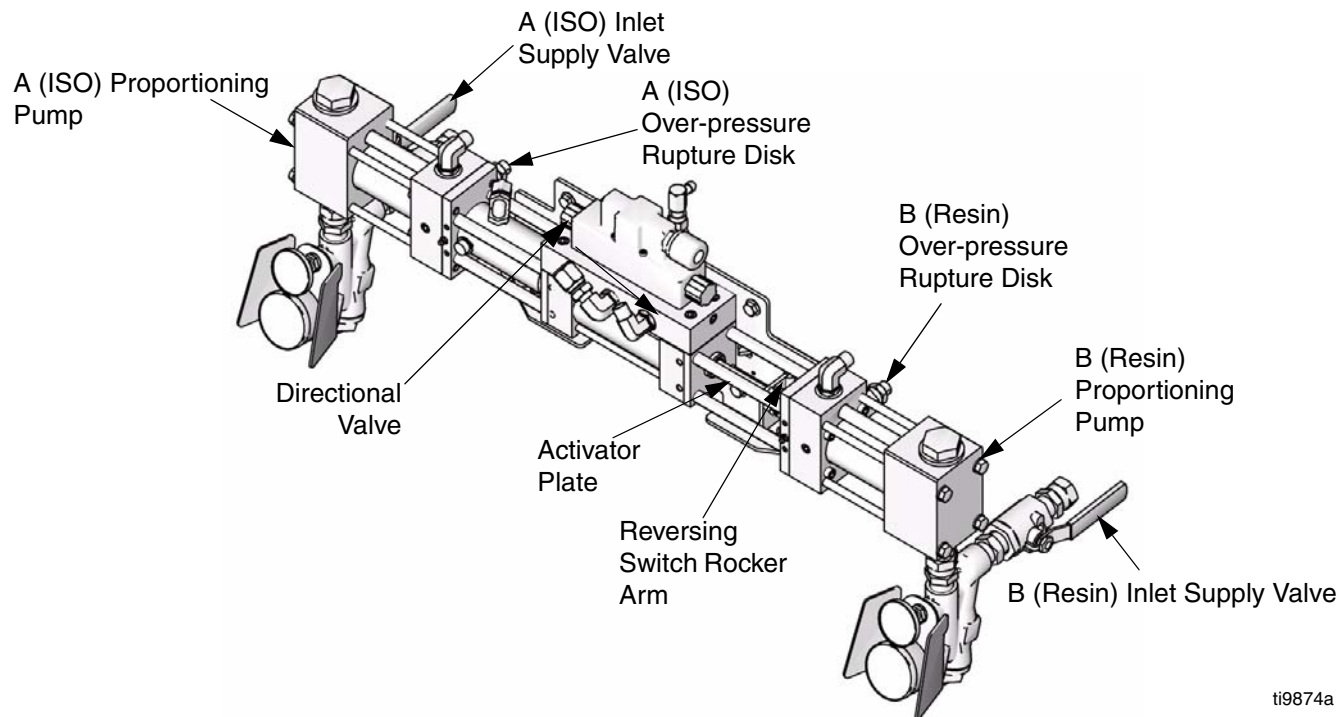

ti9874a

FIG. 1. Proportioning System

Table 2. Directional Valve Indicator Status

Left Pump Directional Indicator Lighted	Right Pump Directional Indicator Lighted
B-side pump piston valve dirty or damaged	B-side pump inlet valve dirty or damaged
A-side pump inlet valve dirty or damaged	A-side pump piston valve dirty or damaged

Pressure/Material Imbalance

To determine which component is out of balance, check the color of some sprayed material. Two-component materials are usually a mix of light and dark fluids, so the under-proportioned component can often be readily determined.

When you have determined which component is under-proportioned, spray off-target, focusing on the pressure gauge for that component.

For example: if component B is under-proportioned, focus on the B-side pressure gauge. If the B gauge reads considerably higher than the A gauge, the problem is at the gun. If the B gauge reads considerably lower than the A gauge, the problem is at the pump.

Pumps Do Not Reverse Direction

1. For the proportioning pumps to reverse direction, the activator plate (219) must contact the rocker arm to activate the reversing switch (210). Check for a bent or loose activator plate, rocker arm, or reversing switch. See FIG. 1 on page 25, and the parts drawing on page 58.
2. Check the function of the directional valve. Direction indication lights should switch on and off based on the reversing switch (210) position. LEDs D19 and D20 (near J5 reversing switch connector on motor board) should alternately illuminate based on the reversing switch position.

There are two possible problems with the directional valve:

- a. If D19 and D20 do not alternately illuminate, the possible causes include:
 - faulty reversing switch wiring,
 - faulty reversing switch, or
 - faulty motor board.

To resolve this problem:

- verify the continuity of each reversing switch wire. Replace faulty wires.
- verify reversing switch. Unplug the J5 reversing switch connector. Verify that continuity alternates between NC2 to com and N03 to com by toggling the reversing switch (see Electrical Diagrams manual 312064). If continuity does not alternate, replace the reversing switch and reconnect the J5 reversing switch connector.
- if the reversing switch and wiring are not the cause, and D19 and D20 will not alternately illuminate, replace the motor board.

- b. If D19 and D20 do illuminate but the direction indication lights do not, the possible causes include:
 - faulty motor board,
 - faulty directional valve wiring, or
 - faulty directional valve.

To resolve this problem:

- verify the motor board output voltages at the J18 directional valve connector. When the reversing switch is toggled one direction, there should be 230V output between pins 1 and 2 (A+ and A-). When it is toggled the other direction, there should be 230V output between pins 3 and 4 (B+ and B-). If output voltages are not present, replace the motor board.
- verify continuity of each directional valve wire and verify wiring connections (see Electrical Diagrams manual 312064).
- if motor board and wiring are not the cause, replace the directional valve.



For diagnostic purposes, it is possible to manually override the directional valve by using a small screwdriver to depress the button in the center of either directional valve end cap. Depressing the button in the right end cap should cause the pump to travel to the right. Depressing the left button should cause the pump to travel to the left.

3. If you have determined that the cause is none of the above, check for a loose piston packing retaining bolt. This causes the piston to contact the inner face of the pump inlet flange before the activator plate contacts the rocker arm. Shut down the unit and disassemble the appropriate pump for repair.

Repair

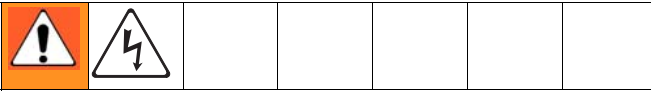

Repairing this equipment requires access to parts that may cause electric shock or other serious injury if work is not performed properly. Have a qualified electrician connect power and ground to main power switch terminals, see operation manual. Be sure to shut off all power to the equipment before repairing.

Pressure Relief Procedure



1. Relieve pressure in gun and perform gun shutdown procedure. See gun manual.
2. Close gun fluid manifold valves A and B.



ti2421a

3. Shut off feed pumps and agitator, if used.

4. Turn PRESSURE RELIEF/SPRAY valves (SA, SB) to PRESSURE RELIEF/CIRCULATION . Route fluid to waste containers or supply tanks. Ensure gauges drop to 0.

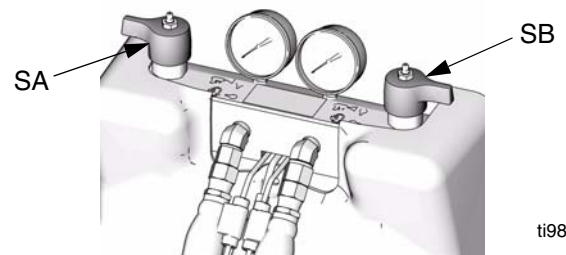

ti9879a

5. Engage gun piston safety lock.



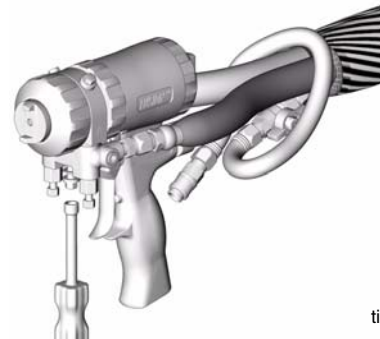

ti2409a

6. Disconnect gun air line and remove gun fluid manifold.



ti2554a

Flushing

							
<p>Flush equipment only in a well-ventilated area. Do not spray flammable fluids. Do not turn on heaters while flushing with flammable solvents.</p>							

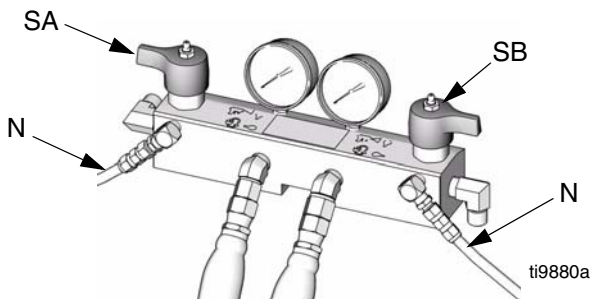

- Flush out old fluid with new fluid, or flush out old fluid with a compatible solvent before introducing new fluid.
- Use the lowest possible pressure when flushing.
- All fluid components are compatible with common solvents. Use only moisture-free solvents.
- To flush feed hoses, pumps, and heaters separately from heated hoses, set PRESSURE RELIEF/SPRAY valves (SA, SB) to PRESSURE

RELIEF/CIRCULATION . Flush through bleed lines (N).





- To flush entire system, circulate through gun fluid manifold (with manifold removed from gun).
- To prevent moisture from reacting with isocyanate, always leave the system dry or filled with a moisture-free plasticizer or oil. Do not use water.

Proportioning Pumps

							
---	---	--	--	--	--	--	--

 See manual 312068 for pump repair instructions.

1. Shut off **A** , **B** , and  heat zones.
2. Flush, page 28.
3. If pumps are not parked, press . Trigger gun until pumps stop.
4. Turn main power OFF . Disconnect power supply.
5. Shut off both feed pumps. Close both fluid inlet ball valves (B).

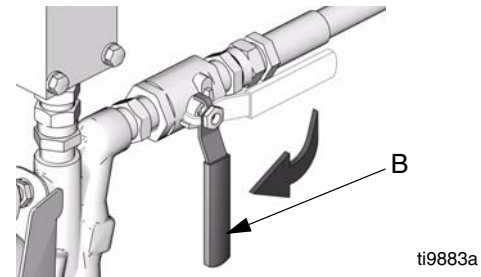

6. Turn both PRESSURE RELIEF/SPRAY valves (SA, SB) to PRESSURE RELIEF/CIRCULATION . Route fluid to waste containers or supply tanks. Ensure gauges drop to 0.

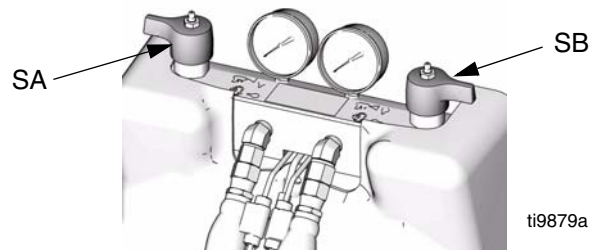

 Use drop cloth or rags to protect Reactor and surrounding area from spills.

- See FIG. 2. Disconnect the B (Resin) side pump inlet and outlet lines. Remove the pin (219) from the clevis (218) to disconnect the pump from the hydraulic cylinder (201). Remove the four screws (203) holding the pump to the spacers (413) of the cylinder. Take the pump assembly to a workbench.

 Torque to 200 in-lb (22.6 N•m).

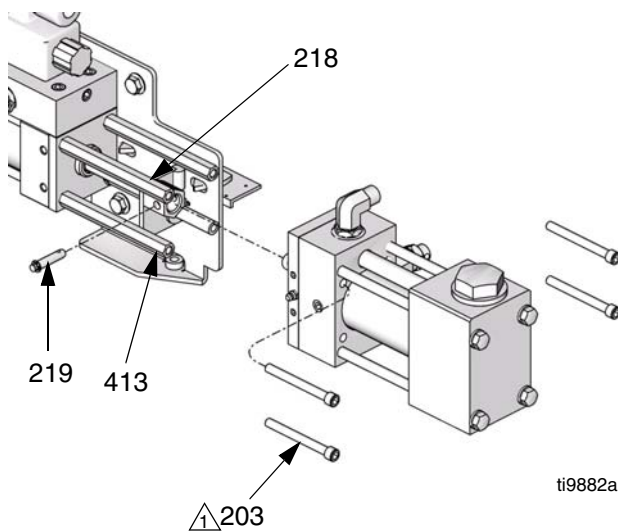



FIG. 2. Proportioning Pump - B Side

- See FIG. 3. Disconnect the A (ISO) side pump inlet and outlet lines. Use the pin extractor tool (244) to remove the pin (219), which disconnects the pump from the hydraulic cylinder (201). Remove the four screws (203) holding the pump to the spacers (413) of the cylinder. Take the pump assembly to a workbench.

 Torque to 200 in-lb (22.6 N•m).

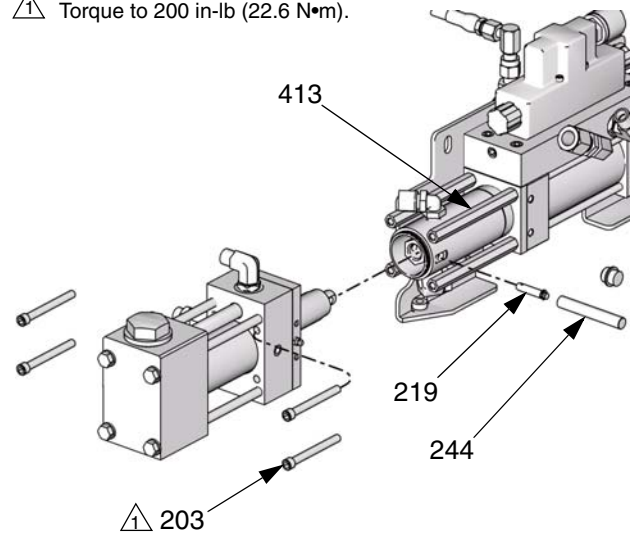
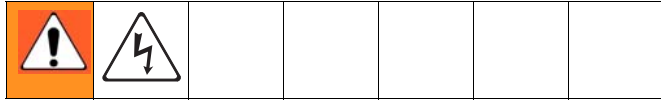

FIG. 3: Proportioning Pump - A Side

- See manual 312068 for pump repair instructions.
- Reconnect the pump in the reverse order. Torque the screws (203) to 200 in-lb (22.6 N•m).

Circuit Breaker Module

1. Turn main power OFF . Disconnect power supply. Turn circuit breakers on to test.



2. Relieve pressure, page 27.
3. Using an ohmmeter, check for continuity across circuit breaker (top to bottom). If no continuity, trip breaker, reset, and retest. If still no continuity, replace breaker as follows:
 - a. Refer to electrical diagrams and to TABLE 3. Disconnect wires and remove bad breaker.
 - b. Install new breaker and reconnect wires.

Table 3: Circuit Breakers, see FIG. 4

Ref.	Size	Component
809	50A	Hose/Transformer Secondary Side
811	40A	Transformer Primary
812A	25A, 40A, or 50A*	Heater A
812B	25A, 40A, or 50A*	Heater B
813	20A or 30A*	Motor/Pumps

* Depending on model.

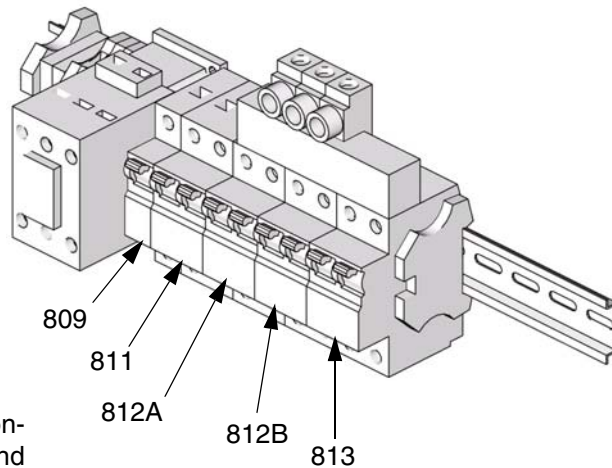

NOTE: To reference cables and connectors, see the electrical diagrams and the parts drawings on pages 67-68.

ti9884a

FIG. 4. Circuit Breaker Module

Electric Motor

Removal

1. Turn main power OFF . Disconnect power supply.

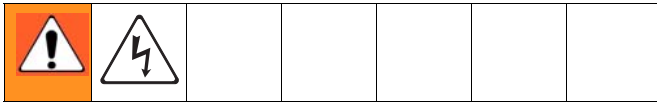

2. Relieve pressure, page 27.
3. Remove motor shroud.
4. Disconnect motor cables as follows:
 - a. Refer to electrical diagrams in the Reactor Electrical Diagram manual 312064. Motor control board is on right side inside cabinet, see page 32.
 - b. Remove motor electric junction box cover.
 - c. Make a note of or label the wire connections. Refer to the Reactor Electrical Diagram manual 312064 and the diagram inside the motor junction box cover. The motor must operate counterclockwise when looking at the output shaft.

CAUTION
Motor is heavy. Two people may be required to lift.

5. Remove screws holding motor to bracket. Lift motor off unit.

Installation

1. Place motor on unit.
2. Fasten motor with screws.
3. Connect the wires, using wire nuts. Refer to the Reactor Electrical Diagram manual 312064 and the diagram inside the motor junction box cover. The motor must operate counterclockwise when looking at the output shaft.



3-Phase Motors: motor must rotate counterclockwise when viewed from shaft end. If rotation is incorrect, reverse power leads L1 and L2. See Reactor Operation manual 312062, Connect Electrical Cord.

4. Return to service.

Motor Control Board

 Motor control board has one red LED (D11). Power must be on to check. See FIG. 5 for location. Function is:

- Startup: 1 blink for 60 Hz, 2 blinks for 50 Hz.
- Motor running: LED on.
- Motor not running: LED off.
- Diagnostic code (motor not running): LED blinks diagnostic code, pauses, then repeats (for example, E21=21 blinks, pause, 21 blinks).

CAUTION
Before handling board, put on a static conductive wrist strap to protect against static discharge which can damage board. Follow instructions provided with wrist strap.

1. Turn main power OFF . Disconnect power supply.

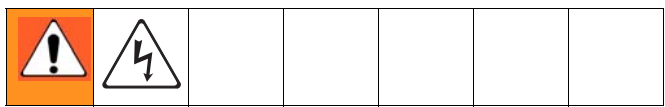

2. Relieve pressure, page 27.
3. Refer to electrical diagrams. Motor control board is on right side inside cabinet.
4. Put on static conductive wrist strap.
5. Disconnect all cables and connectors from board.
6. Remove nuts (40) and take entire motor control assembly to workbench.
7. Remove screws and take board off heatsink.
8. Set DIP switch (SW2) on new board. See TABLE 4 for factory settings. See FIG. 5 for location on board.



						
To prevent overpressurization, DIP switch 2 must be set to ON for Model H-25.						

Table 4: DIP Switch (SW2) Settings

DIP Switch	ON (up)	OFF (down)
Switch 1	Motor soft start ON (factory default)	Motor soft start OFF (Not applicable to 3-phase motors)
Switch 2	ON for pressure imbalance alarm (factory default)	OFF for pressure imbalance warning
Switch 3	Standby ON	Standby OFF (factory default)
Switch 4	ON for Models H-25 and H-40 (system dependent)	OFF for Models H-XP2 and H-XP3 (system dependent)

9. Install new board in reverse order. Apply thermal heatsink compound to mating surfaces of board and heatsink.

 Order Part 110009 Thermal Compound.

Table 5: Motor Control Board Connectors

Connector	Pin	Description
J1	n/a	Main power
J3	n/a	Transducer A
J4	n/a	Not used
J7	n/a	Not used
J8	n/a	Transducer B
J9	n/a	Motor thermostat (NC)
J10	n/a	Not used
J12	n/a	Data reporting
J13	n/a	To display board
J14	n/a	Motor power
J18	1	Directional valve, A+
	2	Directional valve, A-
	3	Directional valve, B+
	4	Directional valve, B-
	5	GND
J5	1	Unused (VDD)
	2	Pumpline reversing switch (COM)
	3	Pumpline reversing switch (NC)
	4	Pumpline reversing switch (NO)

Motor Control

DIP Switch (SW2) Settings

Models H-25, H-40, H-50

ON

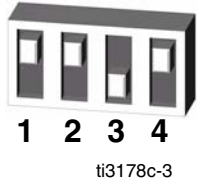

Models H-XP2 & H-XP3

ON

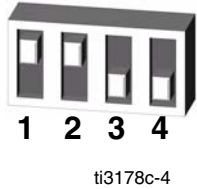

⚠ Apply 110009 thermal heatsink compound to mating surfaces.

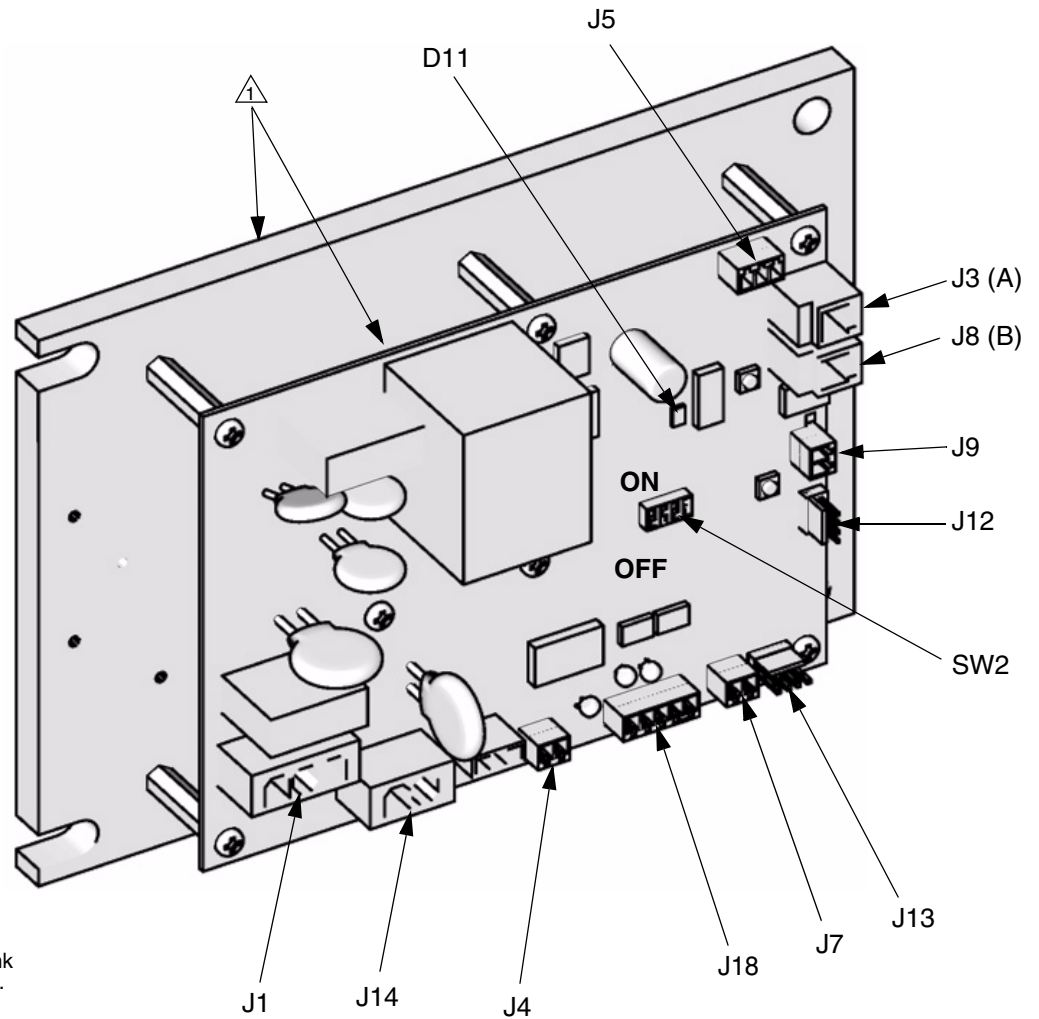

ti7724a

FIG. 5. Motor Control Board

Transducers

1. Turn main power OFF . Disconnect power supply.

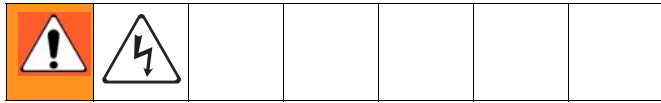

2. Relieve pressure, page 27.
3. Refer to electrical diagrams. Motor control board is on right side inside cabinet.
4. Disconnect transducer cables at board; see FIG. 5, page 33. Reverse A and B connections and check if

diagnostic code follows; see **E21: No component A transducer**, page 12.

5. If transducer fails test, thread cable through top of cabinet. Note path as cable must be replaced in same way.
6. Install o-ring (720) on new transducer (706), FIG. 6.
7. Install transducer in manifold. Mark end of cable with tape (red=transducer A, blue=transducer B).
8. Route cable into cabinet and thread into bundle as before.
9. Connect transducer cable at board; see FIG. 5, page 33.

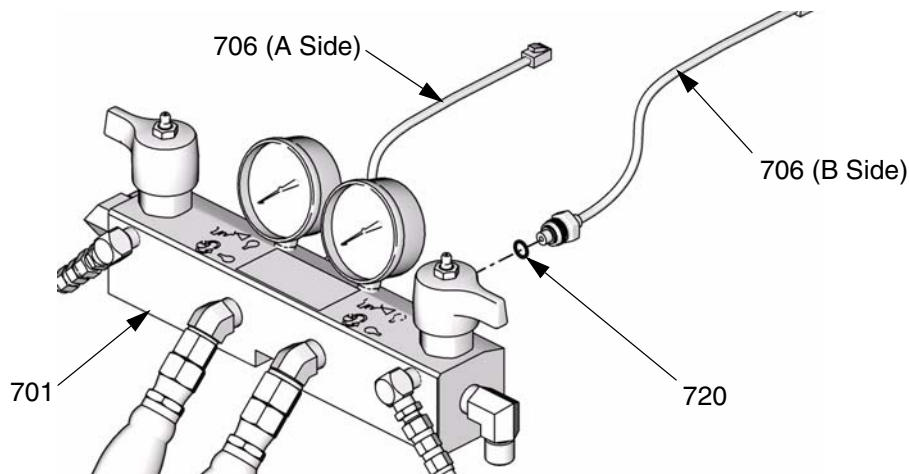

ti9885a

FIG. 6. Transducers

Electric Fan

1. Turn main power OFF . Disconnect power supply.

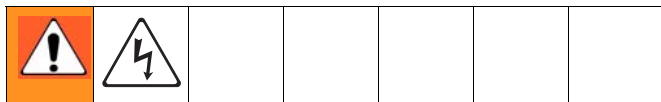

2. Relieve pressure, page 27.
3. Check fuses (F) at left of breaker module, FIG. 7. Replace if blown. If good, continue with step 4.
4. Refer to electrical diagrams. Disconnect fan wires from fuses (F).

5. Remove fan.
6. Install fan in reverse order.

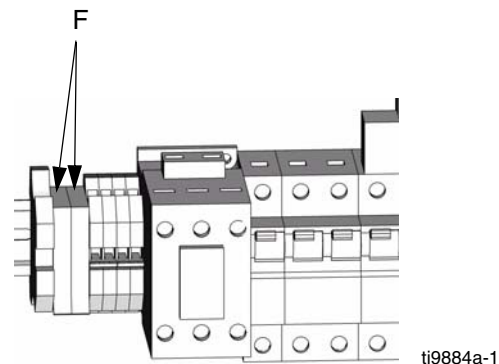

ti9884a-1

FIG. 7. Fan Fuses

Temperature Control Module

Table 6: Temperature Control Module Connections

Connector	Description	
DATA (A)	Data reporting	
SENSOR (B)	PIN	
	12	HOSE T/C P; FTS (purple)
	11	HOSE T/C R; FTS (red)
	10	HOSE T/C S; FTS (silver (unshielded bare wire))
	9	HEATER T/C B, Y; Thermocouple (yellow)
	8	HEATER T/C B, R; Thermocouple (red)
	7	Not used
	6	HEATER T/C A, Y; Thermocouple (yellow)
	5	HEATER T/C A, R; Thermocouple (red)
	4, 3	OVERTEMPERATURE B; Overtemperature switch B
2, 1	OVERTEMPERATURE A; Overtemperature switch A	
DISPLAY (C)	Display	
COMMUNICATION (D)	Communication to power boards	
PROGRAM (E)	Software programming	
BOOT (F)	Software bootloader	
POWER/RELAY (G)	Circuit board power input and contactor control output	

Table 7: Temperature Power Module Connections

Connector	Description
COMMUNICATION (H)	Communication to control board
POWER (J)	Power to heater

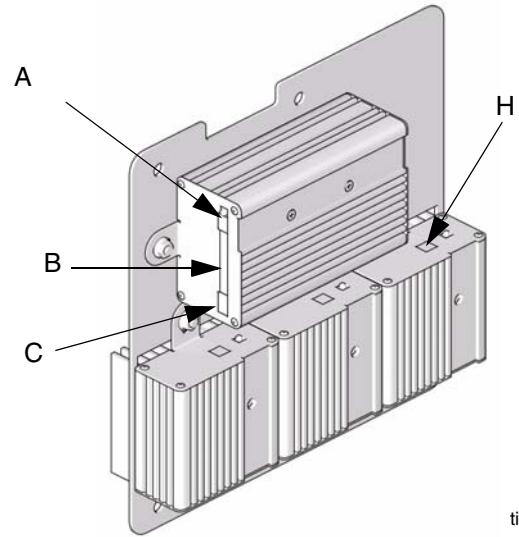

ti9875a

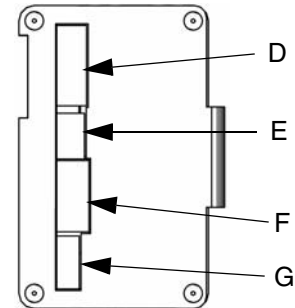

ti9843a1

Right Side of Control Heater Module

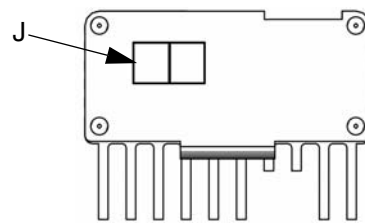







ti9843a4

Bottom of Power Modules

FIG. 8: Temperature Control Module Connections

Test SCR Circuit

1. Test the SCR circuit in the on position:
 - a. Make sure everything is connected, including the hose.
 - b. Turn main power ON  .
 - c. Adjust the hose heat setpoint **above** the ambient hose temperature.
 - d. Turn on  heat zone by pressing  .
 - e. Hold down  to view electrical current.
Hose current should ramp up to 45A. If there is no hose current, see **E03: No zone current**, page 9. If hose current exceeds 45A, see **E02: High zone current**, page 9. If hose current stays several amps below 45A, hose is too long or voltage is too low.

2. Test the SCR circuit in the off position:
 - a. Make sure everything is connected, including the hose.
 - b. Turn main power ON  .
 - c. Adjust the hose heat setpoint **below** the ambient hose temperature.
 - d. Turn on  heat zone by pressing  .
 - e. Using a voltmeter, carefully measure the voltage at the hose connector. You should not get a voltage reading. If you do, the SCR on the temperature control board is bad. Replace the temperature control assembly.

Replacing Temperature Control Assembly Modules

CAUTION
Before handling assembly, put on a static conductive wrist strap to protect against static discharge which can damage assembly. Follow instructions provided with wrist strap.

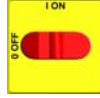
1. Turn main power OFF  . Disconnect power supply.

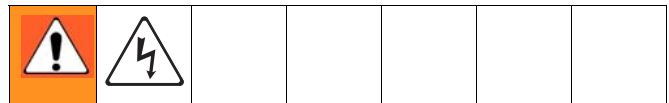

2. Relieve pressure, page 27.
3. Refer to electrical diagrams; see Electrical Diagrams manual 312064. Temperature control assembly is on left side inside cabinet.
4. Remove bolts that secure transformer assembly and slide assembly to side in cabinet.
5. Put on static conductive wrist strap.
6. Disconnect all cables and connectors from assembly; see **Parts - Temperature Control**, page 65.
7. Remove nuts and take entire temperature control assembly to workbench.
8. Replace defective module.
9. Install assembly in reverse order.

Primary Heaters

Heater Element



1. Turn main power OFF . Disconnect power supply.
2. Relieve pressure, page 27.
3. Wait for heaters to cool.
4. Remove heater shroud.
5. See pages 60-62 for illustrations of each heater. Disconnect heater element wires from heater wire connector. Test with ohmmeter.

Total Heater Wattage	Element	Ohms
6,000	1500	30-35
7,650	2550	18-21
8,000	2000	23-26
10,200	2550	18-21

6. To remove heater element, first remove thermocouple (310) to avoid damage, see step 7, page 38.
7. Unscrew heater element (307) from fitting (302). Remove heater element (307) from housing (301). Be careful not to spill any fluid left in housing.
8. Inspect element. It should be relatively smooth and shiny. If there is a crusted, burnt, ash-like material adhered to element or sheath shows pitting marks, replace element.
9. Apply thread sealant to heater element threads and install new heater element (307), holding mixer (309) so it does not block thermocouple port (P).
10. Reinstall thermocouple, page 38.
11. Reconnect heater element leadwires to heater wire connector.
12. Replace heater shroud.

Line Voltage

The primary heaters output their rated wattage at 230 Vac. Low line voltage will reduce power available and the heaters will not perform at full capability.

Thermocouple

1. Turn main power OFF . Disconnect power supply.
2. Relieve pressure, page 27.

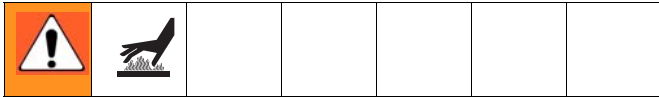

3. Wait for heaters to cool.
4. Remove heater shroud.
5. Disconnect thermocouple wires from B on temperature control module. See TABLE 6, page 35 and FIG. 8, page 35.
6. Feed thermocouple wires out of cabinet. Note path as wires must be replaced in the same way.
7. See FIG. 9. Loosen ferrule nut (N). Remove thermocouple (310) from heater housing (301), then remove thermocouple housing (H). Do not remove the thermocouple adapter (305) unless necessary. If adapter must be removed, ensure that mixer (309) is out of the way when replacing the adapter.

8. Replace thermocouple, FIG. 9.
 - a. Remove protective tape from thermocouple tip (T).
 - b. Apply PTFE tape and thread sealant to male threads and tighten thermocouple housing (H) into adapter (305).
 - c. Push in thermocouple (310) so tip (T) contacts heater element (307).
 - d. Holding thermocouple (T) against heater element, tighten ferrule nut (N) 1/4 turn past tight.
9. Route wires (S) into cabinet and thread into bundle as before. Reconnect wires to board.
10. Replace heater shroud.
11. Turn on heaters A and B simultaneously to test. Temperatures should rise at same rate. If one heater is low, loosen ferrule nut (N) and tighten thermocouple housing (H) to ensure thermocouple tip (T) contacts element (307).

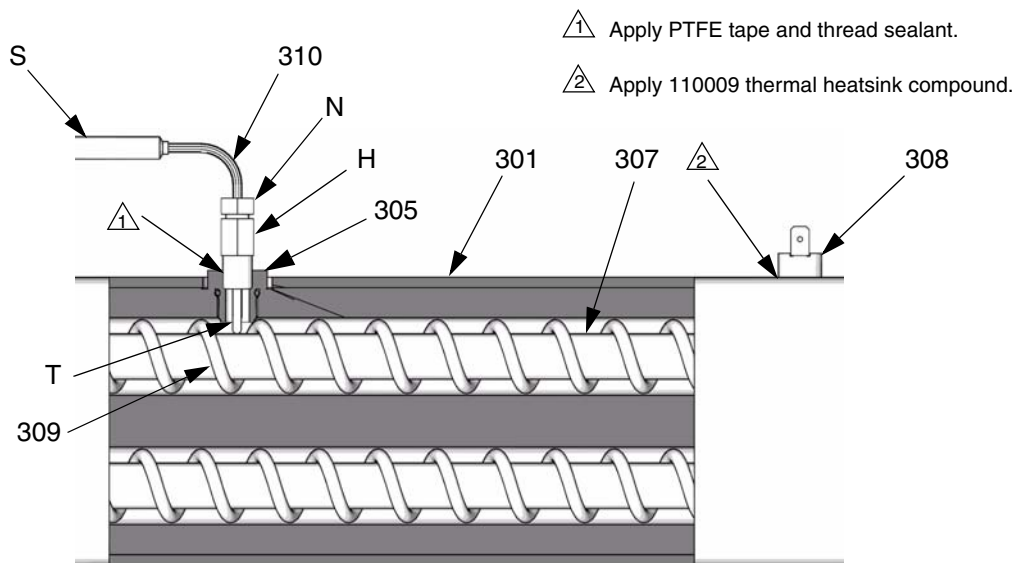

ti7924a

FIG. 9. Thermocouple

Overtemperature Switch

1. Turn main power OFF . Disconnect power supply.
2. Relieve pressure, page 27.

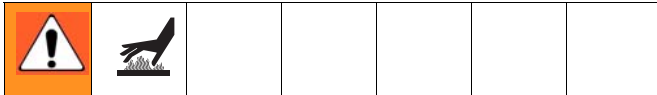

3. Wait for heaters to cool.
4. Remove heater shroud.
5. Disconnect one leadwire from overtemperature switch (308), FIG. 9. Test across switch with ohmmeter. Resistance must be approximately 0 ohms.
6. If switch fails test, remove wires and screws. Discard failed switch. Apply thermal compound 110009, install new switch in same location on housing (301), and secure with screws (311). Reconnect wires.

 If wires need replacement, disconnect from temperature control board. See TABLE 6, page 35 and FIG. 8, page 35.

Heated Hose

 Refer to the heated hose manual 309572 for hose replacement parts.

Check Hose Connectors

1. Turn main power OFF . Disconnect power supply.
2. Relieve pressure, page 27.

 Whip hose must be connected.

3. Disconnect hose connector (D) at Reactor, FIG. 10.

4. Using an ohmmeter, check between the two terminals of the connector (D). There should be continuity.
5. If hose fails test, retest at each length of hose, including whip hose, until failure is isolated.

Check FTS Cables

1. Turn main power OFF . Disconnect power supply.
2. Relieve pressure, page 27.
3. Disconnect FTS cable (F) at Reactor, FIG. 10.

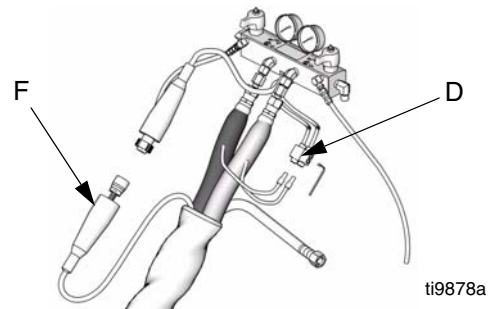

FIG. 10. Heated Hose

4. Test with ohmmeter between pins of cable connector.

Pins	Result
1 to 2	approximately 35 ohms per 50 ft (15.2 m) of hose, plus approximately 10 ohms for FTS
1 to 3	infinity

5. If cable fails test, retest at FTS, page 40.

Fluid Temperature Sensor (FTS)

Test/Removal

1. Turn main power OFF . Disconnect power supply.
2. Relieve pressure, page 27.
3. Remove tape and protective covering from FTS (21), FIG. 10. Disconnect hose cable (F). Test with ohmmeter between pins of cable connector.

Pins	Result
1 to 2	approximately 10 ohms
1 to 3	infinity
3 to FTS groundscrew	0 ohms
1 to FTS component A fitting (ISO)	infinity

4. If FTS fails any test, replace FTS.
5. Disconnect air hoses (C, L), and electrical connectors (D).
6. Disconnect FTS from whip hose (W) and fluid hoses (A, B).
7. Remove ground wire (K) from ground screw on underside of FTS.
8. Remove FTS probe (H) from component A (ISO) side of hose.

Installation

The Fluid Temperature Sensor (FTS) is supplied. Install FTS between main hose and whip hose. See Heated Hose manual 309572 for instructions.

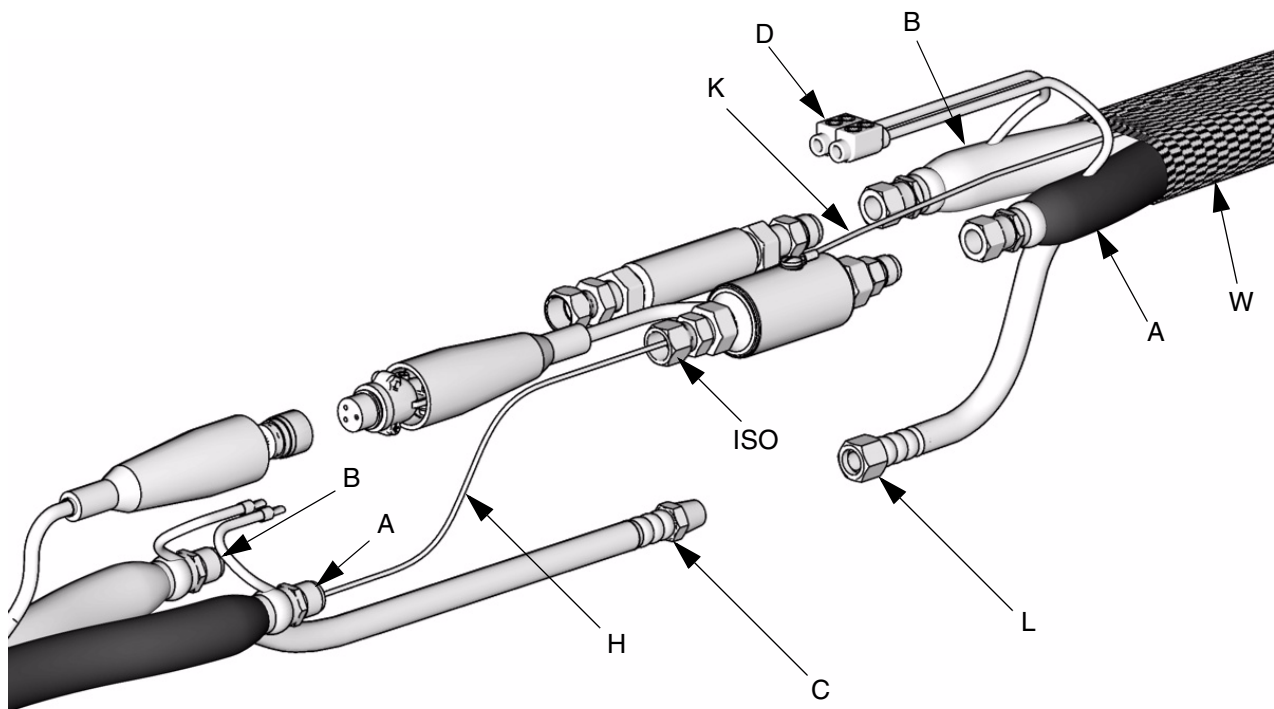

ti9581b

FIG. 11: Fluid Temperature Sensor and Heated Hoses

Transformer Primary Check

1. Turn main power OFF .
2. Locate the two smaller (10 AWG) wires coming out of transformer. Trace these wires back to contactor and circuit breaker (811). Use an ohmmeter to test for continuity between two wires; there should be continuity.

Transformer Secondary Check

1. Turn main power OFF .
2. Locate the two larger (6 AWG) wires coming out of transformer. Trace these wires back to large green connector under hose control module and circuit breaker (809). Use an ohmmeter to test for continuity between two wires; there should be continuity.

If you are not sure which wire in green plug under hose module connects to transformer, test both wires. One wire should have continuity with the other transformer wire in breaker (809) and the other wire should not.

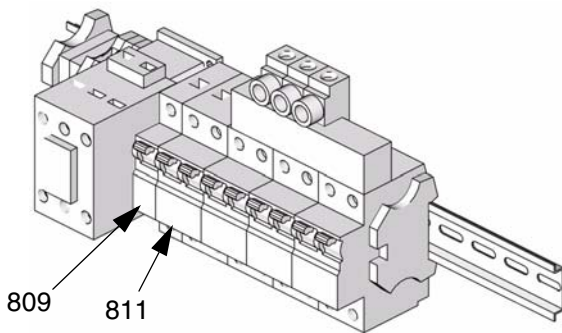



FIG. 12: Circuit Breaker Module

3. To verify transformer voltage, turn on hose zone. Measure voltage from 18CB-2 to POD-HOSE-P15-2; see Reactor Electrical Diagrams manual 312064.

Model	Secondary Voltage
310 ft.	90 Vac*
410 ft.	120 Vac*

* For 230 Vac line voltage.

Replace Transformer

 Use this procedure to replace transformer.

1. Turn main power OFF . Disconnect power supply.

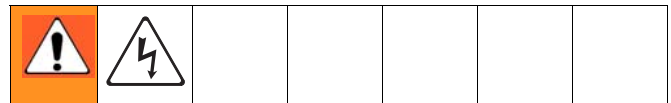

2. Open Reactor cabinet.
3. Remove bolts holding transformer to cabinet floor. Slide transformer forward.
4. Disconnect the transformer wires; see Reactor Electrical Diagrams manual 312064.
5. Remove transformer from cabinet.
6. Install new transformer in reverse order.

Display Module

Temperature and Pressure Displays

CAUTION
Before handling board, put on a static conductive wrist strap to protect against static discharge which can damage board. Follow instructions provided with wrist strap.

1. Turn main power OFF . Disconnect power supply.

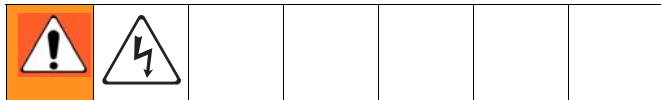

2. Relieve pressure, page 27.
3. Refer to electrical diagrams.
4. Put on static conductive wrist strap.
5. Disconnect main display cable (20) at lower left corner of display module; see FIG. 13.
6. Remove screws (509, 510) and cover (504); see FIG. 13.

 If replacing both displays, label temperature display cables TEMP and pressure display cables PUMP before disconnecting.

7. Disconnect cable connectors (506 and 511) from back of temperature display (501) or pressure display (502); see FIG. 13.
8. Disconnect ribbon cable(s) (R) from back of display; see FIG. 13.
9. Remove nuts (508) and plate (505).
10. Disassemble display, see detail in FIG. 13.
11. Replace board (501a or 502a) or membrane switch (501b or 502b) as necessary.
12. Reassemble in reverse order, see FIG. 13. Apply medium strength thread sealant where shown. Be sure display cable ground wire (G) is secured

between cable bushing and cover (504) with screws (512).

Red Stop Button

CAUTION
Before handling board, put on a static conductive wrist strap to protect against static discharge which can damage board. Follow instructions provided with wrist strap.

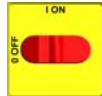
1. Turn main power OFF . Disconnect power supply.

2. Relieve pressure, page 27.
3. Refer to electrical diagrams.
4. Put on static conductive wrist strap.
5. Remove screws (509, 510) and cover (504), FIG. 13.
6. Disconnect button cable connectors (506) from back of temperature display (501) and pressure display (502).
7. Remove red stop button (506).
8. Reassemble in reverse order. Be sure display cable ground wire (G) is secured between cable bushing and cover (504) with screws (512).

⚠ Apply medium strength thread sealant.

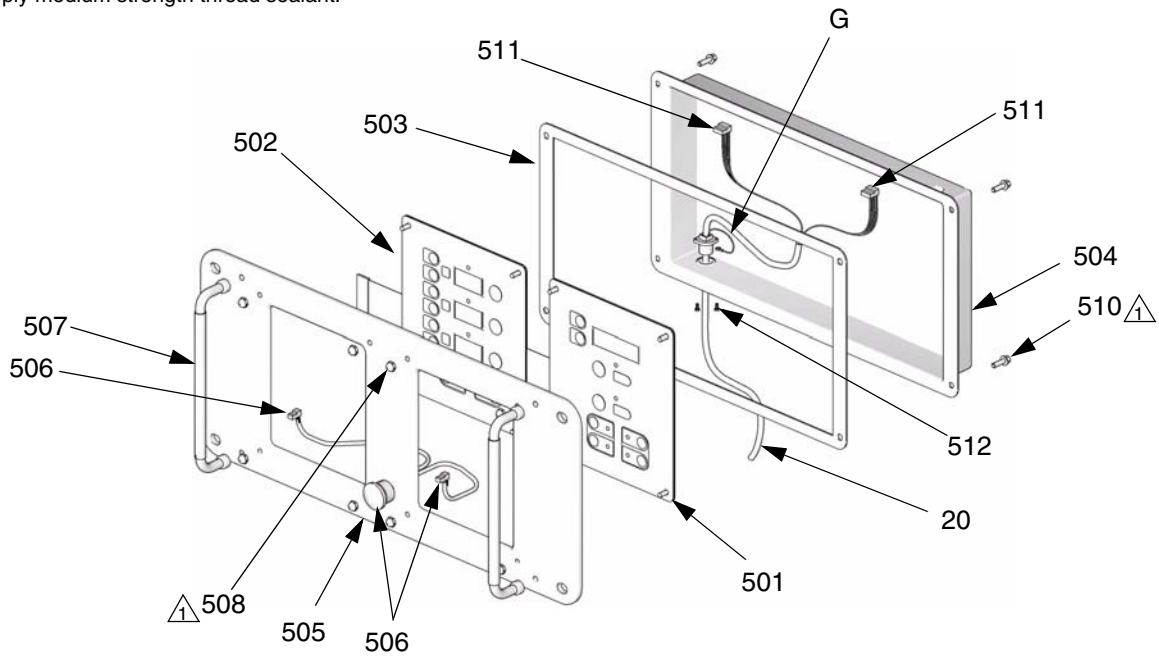

ti2574a

Detail of Membrane Switches and Display Boards

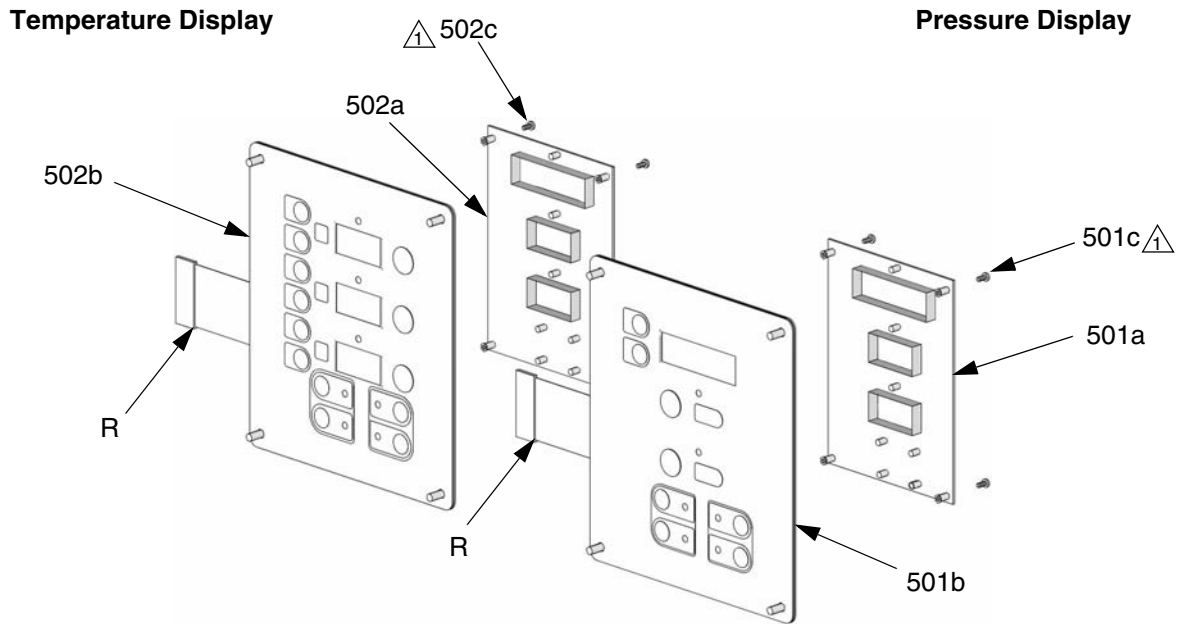

ti3172a

FIG. 13. Display Module

Inlet Fluid Strainer Screen

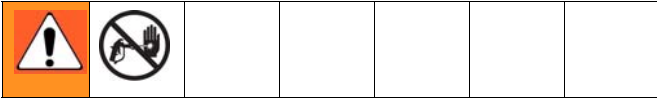

The inlet strainer at each proportioning pump filters out solid matter that can plug the inlet check valves. Inspect the screens daily as part of the startup routine, and clean as required.

Isocyanate can crystallize from moisture contamination or from freezing. If the chemicals used are clean and proper storage, transfer, and operating procedures are followed, there should be minimal contamination of the A-side screen.

 Clean the A-side screen only during daily startup. This minimizes moisture contamination by immediately flushing out any isocyanate residue at the start of dispensing operations.

1. Close the material supply valve at the pump inlet to prevent material from being pumped while the strainer plug (59j) is removed.
2. Place a container under the strainer base to catch drain off when removing the strainer plug.
3. Remove the screen (59g) from the strainer manifold. Thoroughly flush the screen with gun cleaner and shake it dry. Inspect the screen for blockage. No more than 25% of the mesh should be restricted. If more than 25% is blocked, replace the screen. Inspect the strainer gasket (59h) and replace as required.
4. Ensure the pipe plug (59k) is securely screwed into the strainer plug (59j). Install the strainer plug with the screen (59g) and gasket (59h) in place and tighten. Do not overtighten. Let the gasket make the seal.
5. Open the material supply valve, ensure that there are no leaks, and wipe the equipment clean.
6. Proceed with operation.

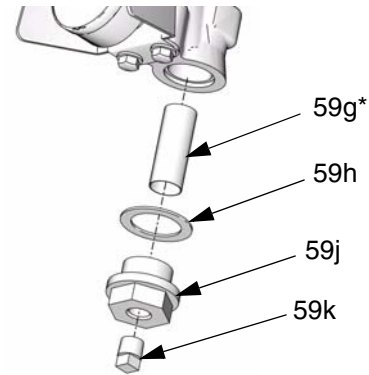

ti9886a

FIG. 14. Y Strainer Components

* Fluid filter screen (59g) replacements:

Part	Description
180199	20 mesh (standard); 1 pack
255082	80 mesh (optional); 2 pack
255083	80 mesh (optional); 10 pack

Pump Lubrication System



Check the condition of the ISO pump lubricant daily. Change the lubricant if it becomes a gel, its color darkens, or it becomes diluted with isocyanate.

Gel formation is due to moisture absorption by the pump lubricant. The interval between changes depends on the environment in which the equipment is operating. The pump lubrication system minimizes exposure to moisture, but some contamination is still possible.

Lubricant discoloration is due to continual seepage of small amounts of isocyanate past the pump packings during operation. If the packings are operating properly, lubricant replacement due to discoloration should not be necessary more often than every 3 or 4 weeks.

To change pump lubricant:

1. Relieve pressure, page 27.
2. Lift the lubricant reservoir (LR) out of the bracket (RB) and remove the container from the cap. Holding the cap over a suitable container, remove the check valve and allow the lubricant to drain. Reattach the check valve to the inlet hose. See FIG. 15.

3. Drain the reservoir and rinse with clean lubricant.
4. When the reservoir is clean, fill with fresh lubricant.
5. Thread the reservoir onto the cap assembly and place it into the bracket.
6. Push the larger diameter supply tube (ST) approximately 1/3 of the way into the reservoir.
7. Push the smaller diameter return tube (RT) into the reservoir until it reaches the bottom.

 **Important:** The return tube (RT) must reach the bottom of the reservoir, to ensure that isocyanate crystals will settle to the bottom and not be siphoned into the supply tube (ST) and returned to the pump.

8. The lubrication system is ready for operation. No priming is required.

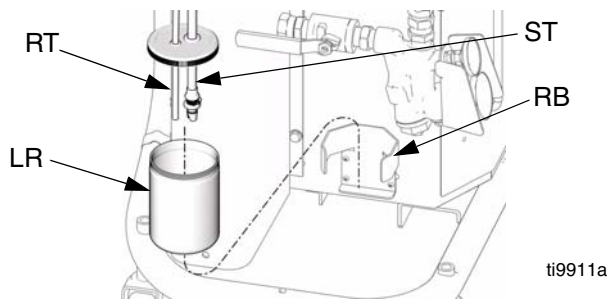

ti9911a

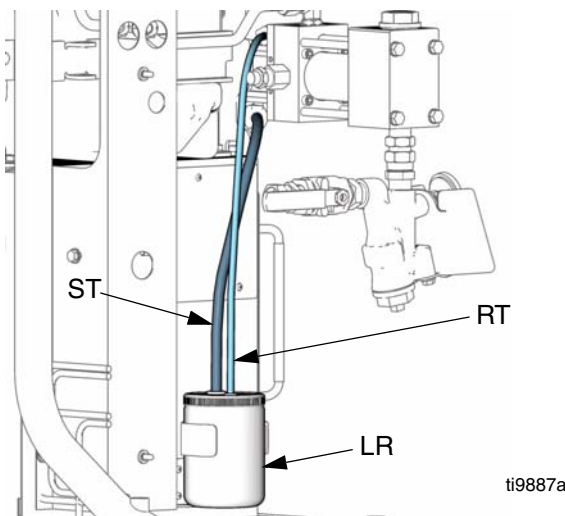

ti9887a

FIG. 15. Pump Lubrication System

Change Hydraulic Fluid and Filter



See Table 8 for recommended frequency of oil changes.

 Change break-in oil in a new unit after first 250 hours of operation or within 3 months, whichever comes first.

Table 8: Frequency of Oil Changes

Ambient Temperature	Recommended Frequency
0 to 90°F (-17 to 32°C)	1000 hours or 12 months, whichever comes first
90°F and above (32°C and above)	500 hours or 6 months, whichever comes first

1. Relieve pressure, page 27.
2. Allow hydraulic fluid to cool.
3. Place a pan under reservoir drain plug (110k) to catch oil.

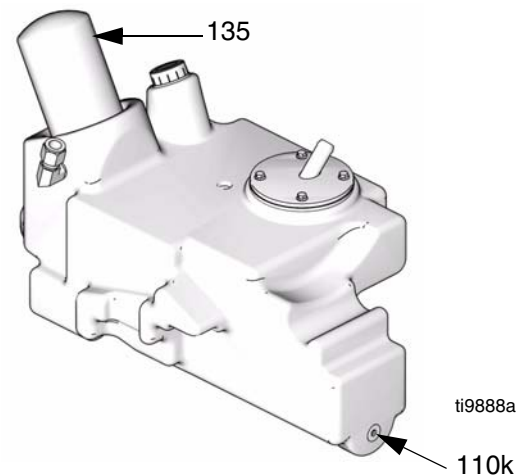

FIG. 16: Change Hydraulic Fluid and Filter

4. Remove drain plug (110k).

5. Place a rag around base of oil filter (135) to prevent oil from spilling. Unscrew filter 1/4-3/4 turn to break air lock in filter. Wait five minutes to allow oil in filter to drain back into reservoir. Unscrew filter and remove.
6. Reinstall drain plug (110k).
7. Replace filter (135):
 - a. Coat filter seal with fresh oil.
 - b. Screw filter on snug, then an additional 1/4 turn.
8. Refill reservoir with approved hydraulic fluid. See Table 9.
9. Proceed with normal operation.

 Upon starting motor, hydraulic pump may make a screeching noise until primed. If this noise continues for more than 30 seconds, switch off motor control. See **Hydraulic Drive System**, page 21.

Table 9: Approved Anti-Wear (AW) Hydraulic Oils

Supplier	Name
Citgo	A/W ISO Grade 46
Amsoil	AWI ISO Grade 46 (synthetic*)
BP Oil International	Energol [®] HLP-HM, ISO Grade 46
Carl Bechem GmbH	Staroil HVI 46
Castrol	Hyspin AWS 46
Chevron	Rykon [®] AW, ISO 46
Exxon	Humble Hydraulic H, ISO Grade 46
Mobil	Mobil DTE 25, ISO Grade 46
Shell	Shell Tellus, ISO Grade 46
Texaco	Texaco AW Hydraulic, ISO Grade 46
* Note: Do not mix mineral-based and synthetic hydraulic oils. Completely drain oil from reservoir and pump prior to converting between oils.	
If the approved oils are not available in your area, use an alternative hydraulic oil meeting the following requirements:	
Oil Type:	Anti-Wear (AW) Hydraulic
ISO Grade:	46
Viscosity, cSt at 40°C:	43.0-47.0
Viscosity, cSt at 100°C:	6.5-9.0
Viscosity Index:	95 or higher
Pour Point, ASTM D 97:	-15°F (-26°C) or lower
Other essential properties:	Formulated for anti-wear, anti-foaming, oxidation stability, corrosion protection, and water separation

Parts

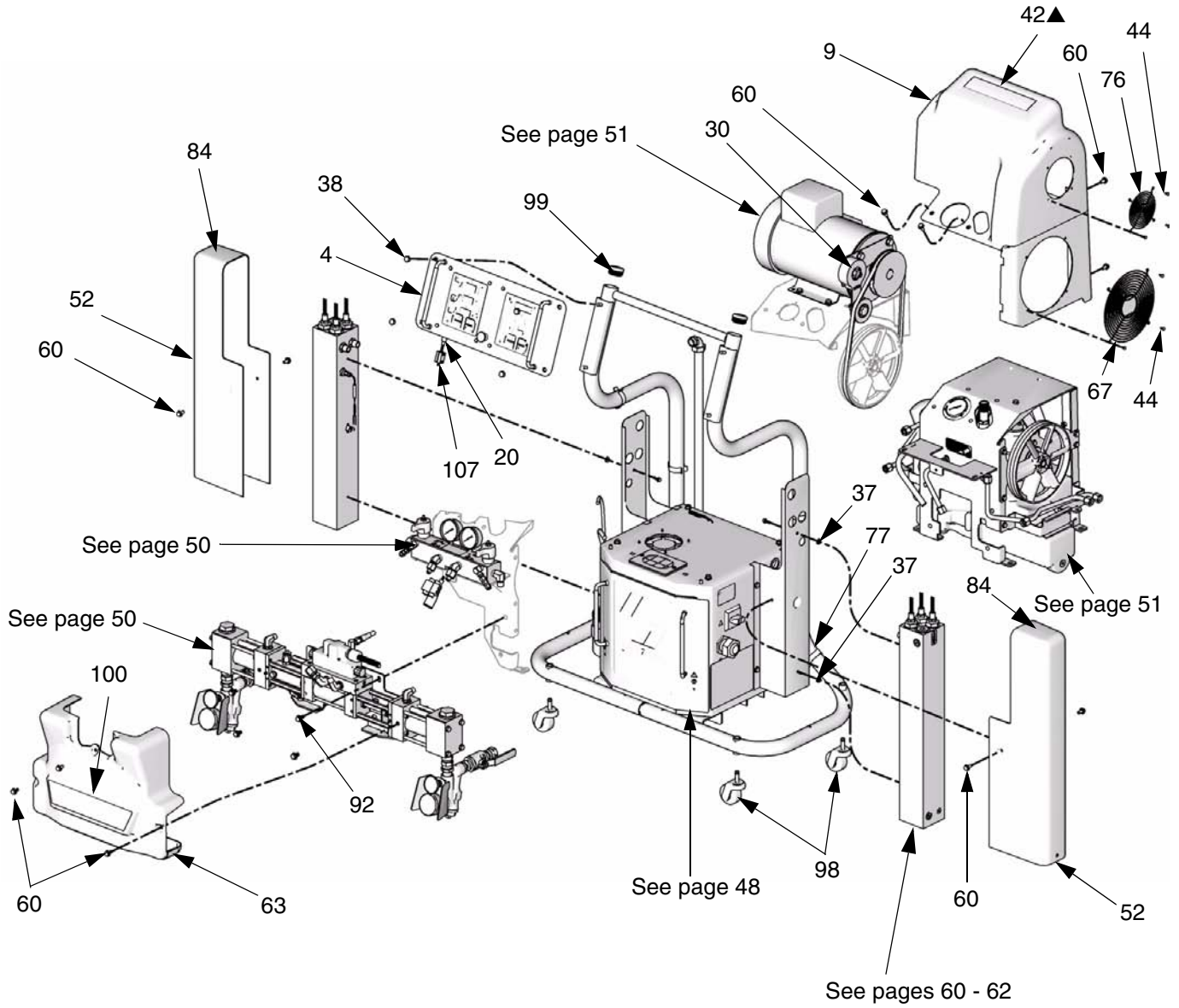

t19831a

Detail of Cabinet Area

8.0 kW Heater Bracket (Ref. 36) Shown

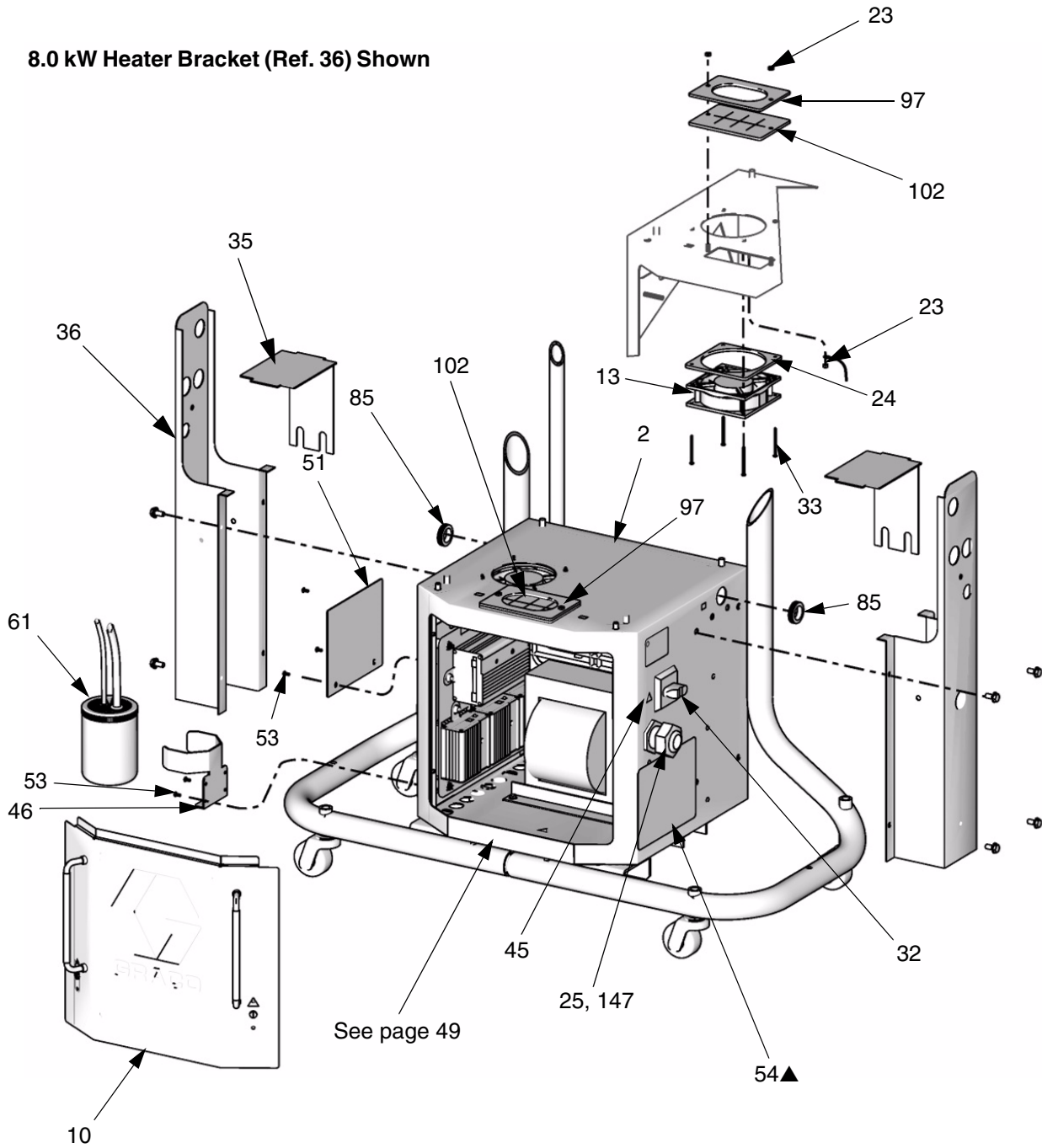

T19834a

Left Side of Cabinet

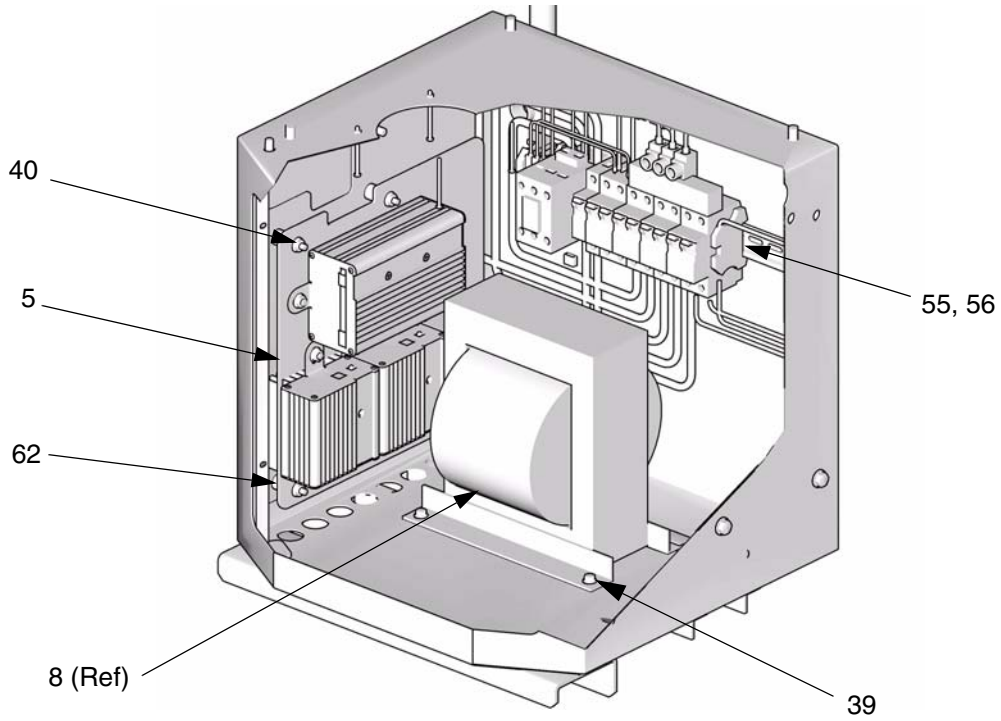

T19835a

Right Side of Cabinet

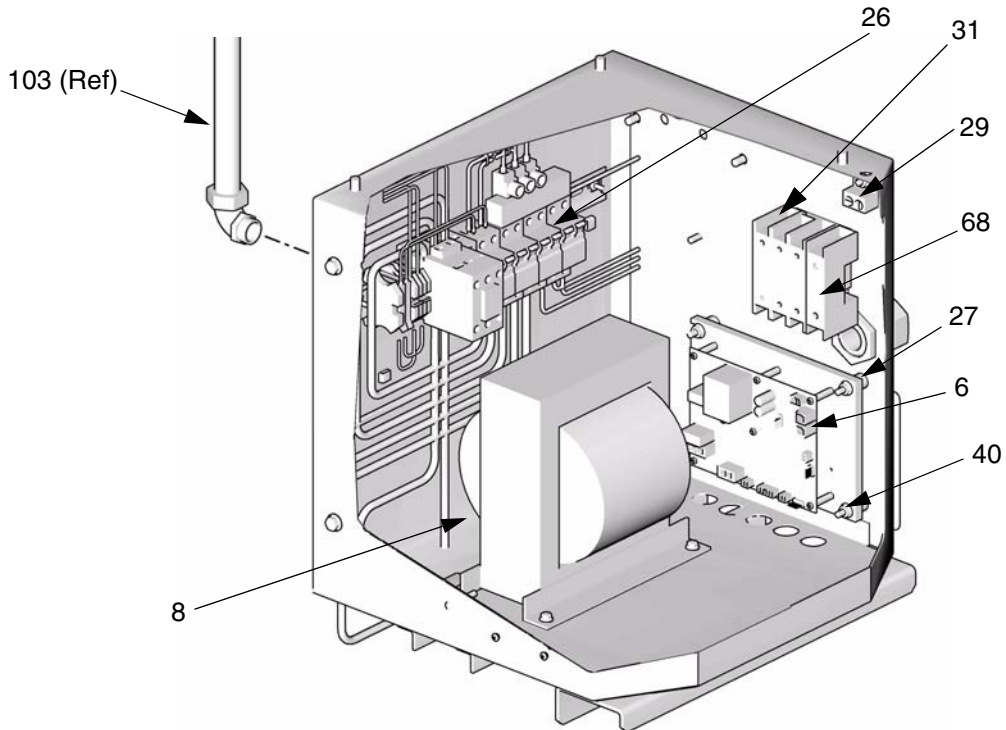

T19836a

Detail, Fluid Manifold Area

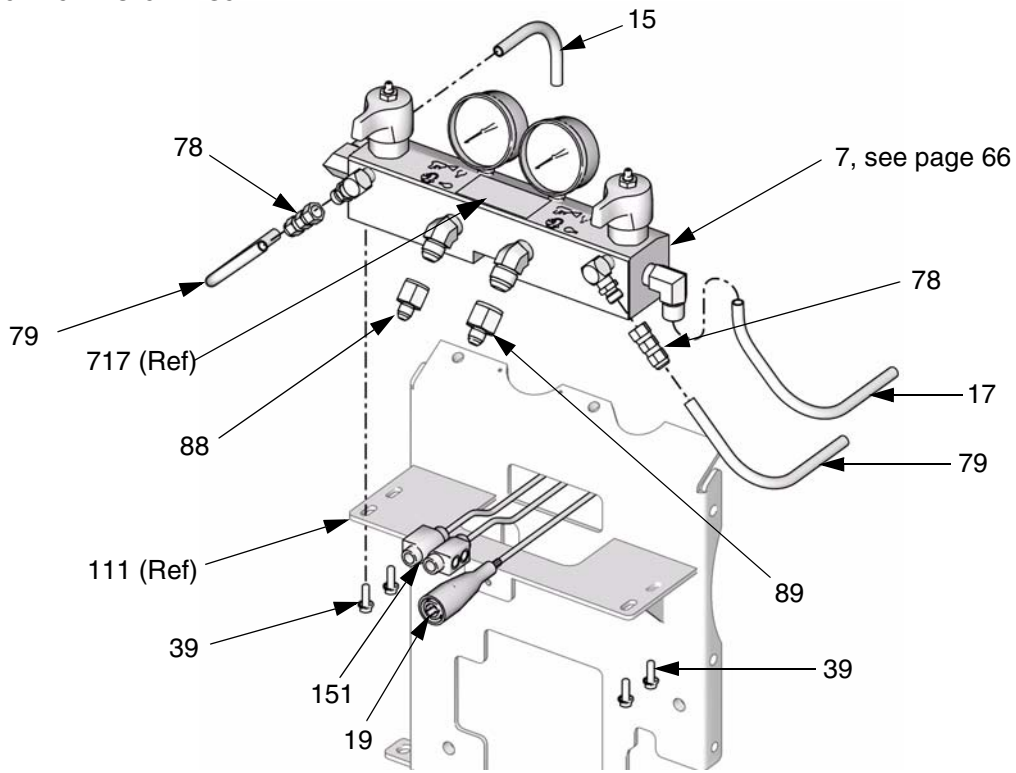

TI9838a

Detail, Proportioner Area

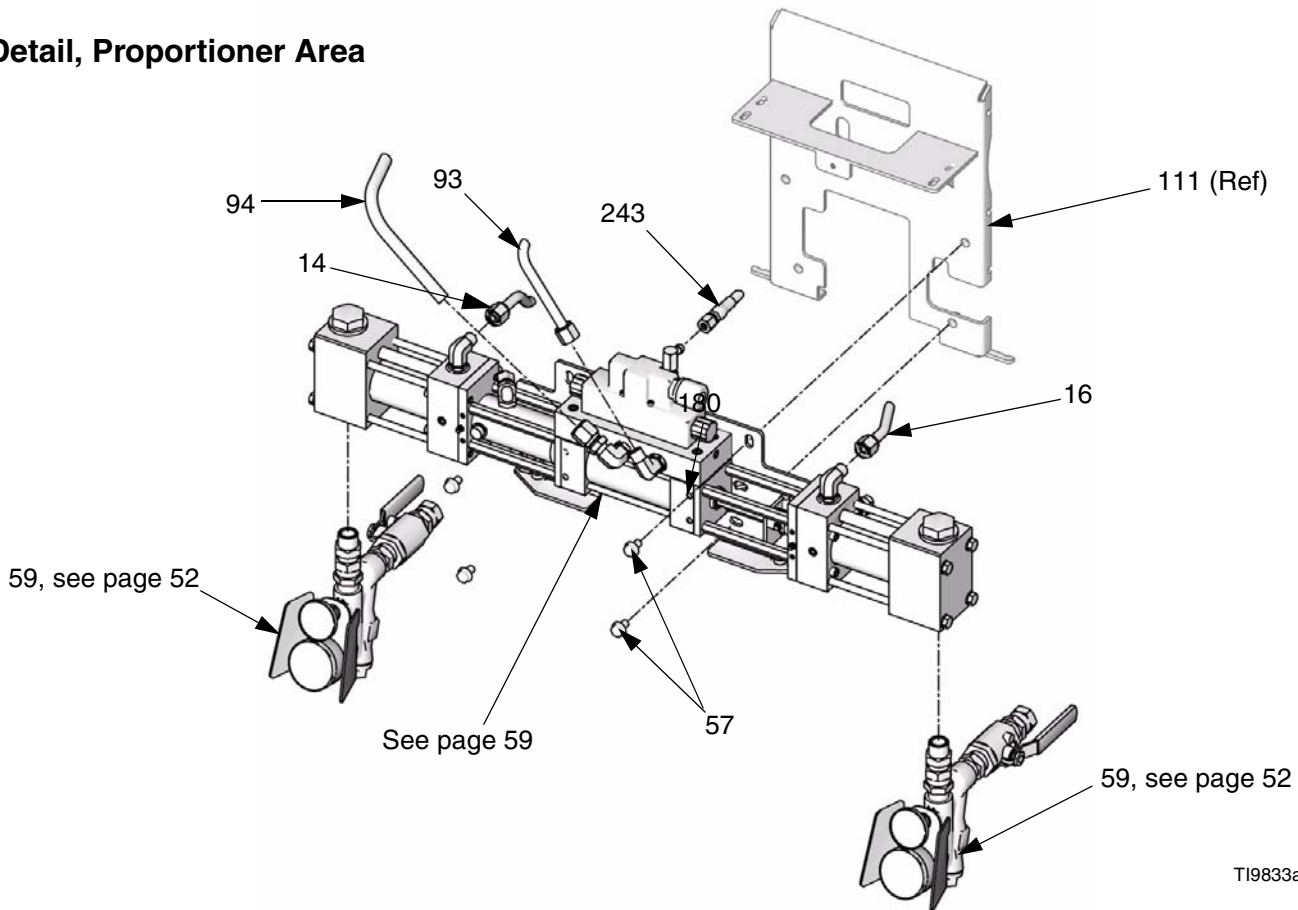

TI9833a

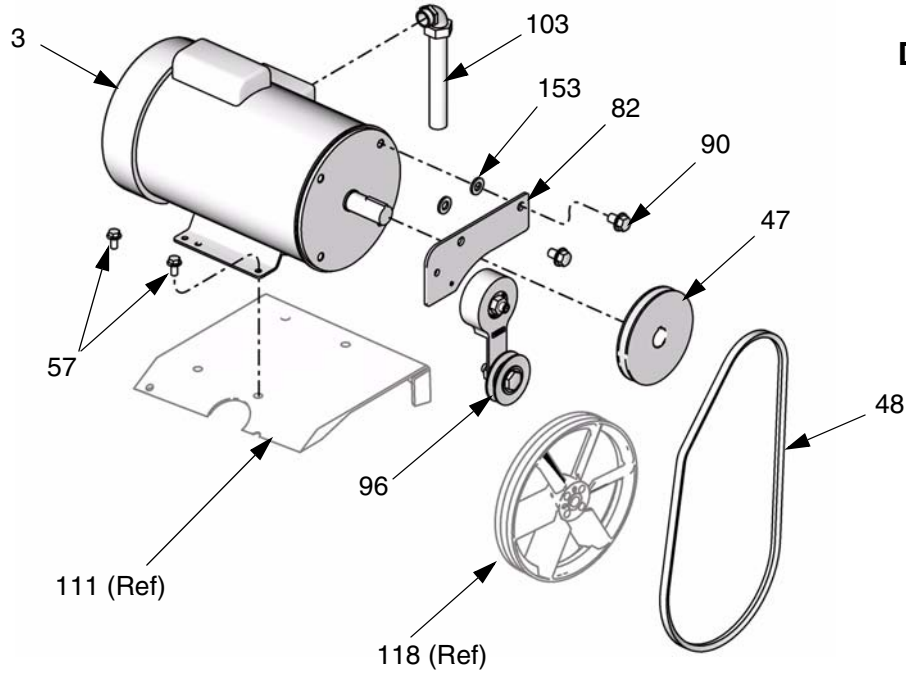

ti7709a

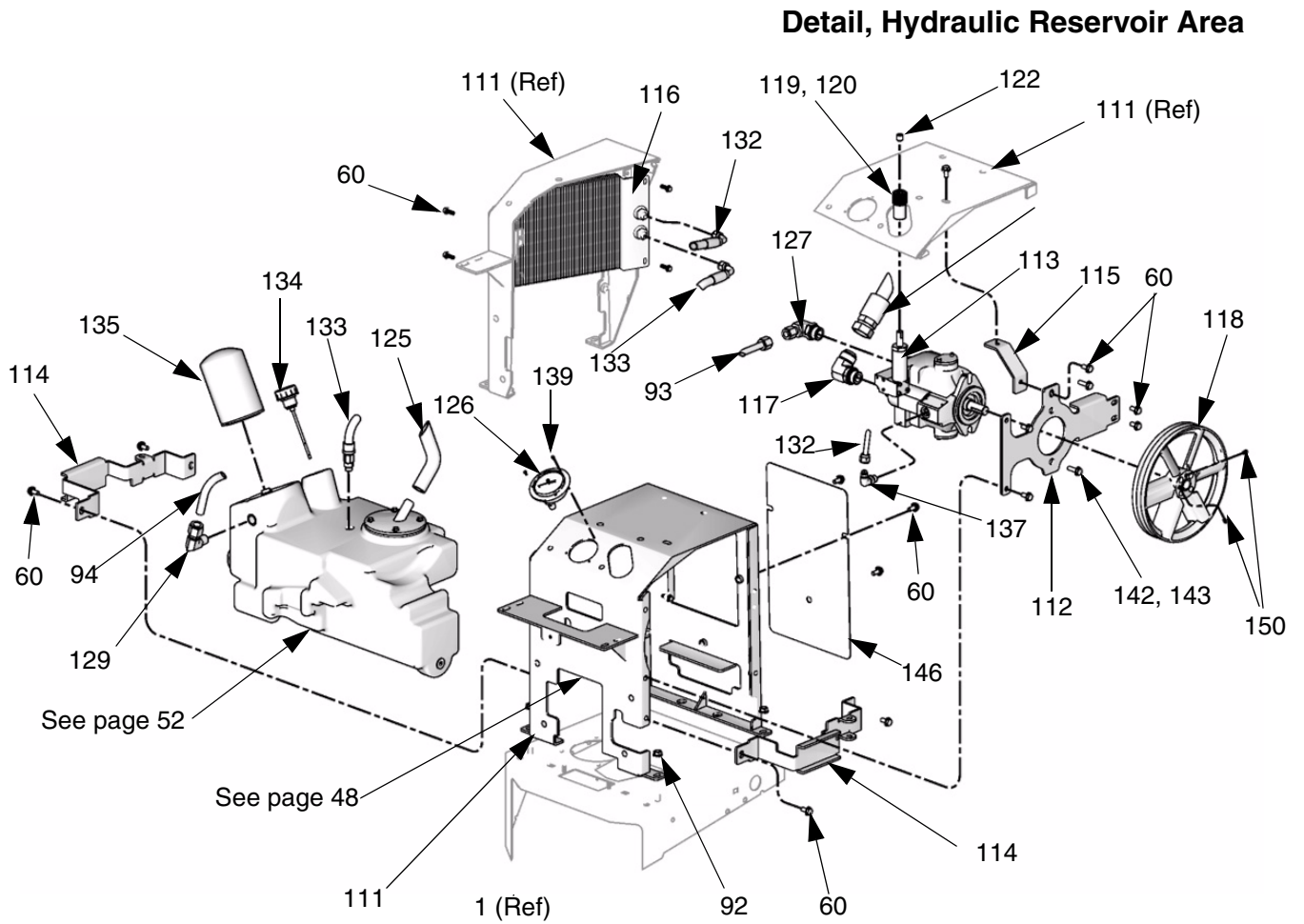

T19832b

Ref. 59, Fluid Inlet Kit

A Side

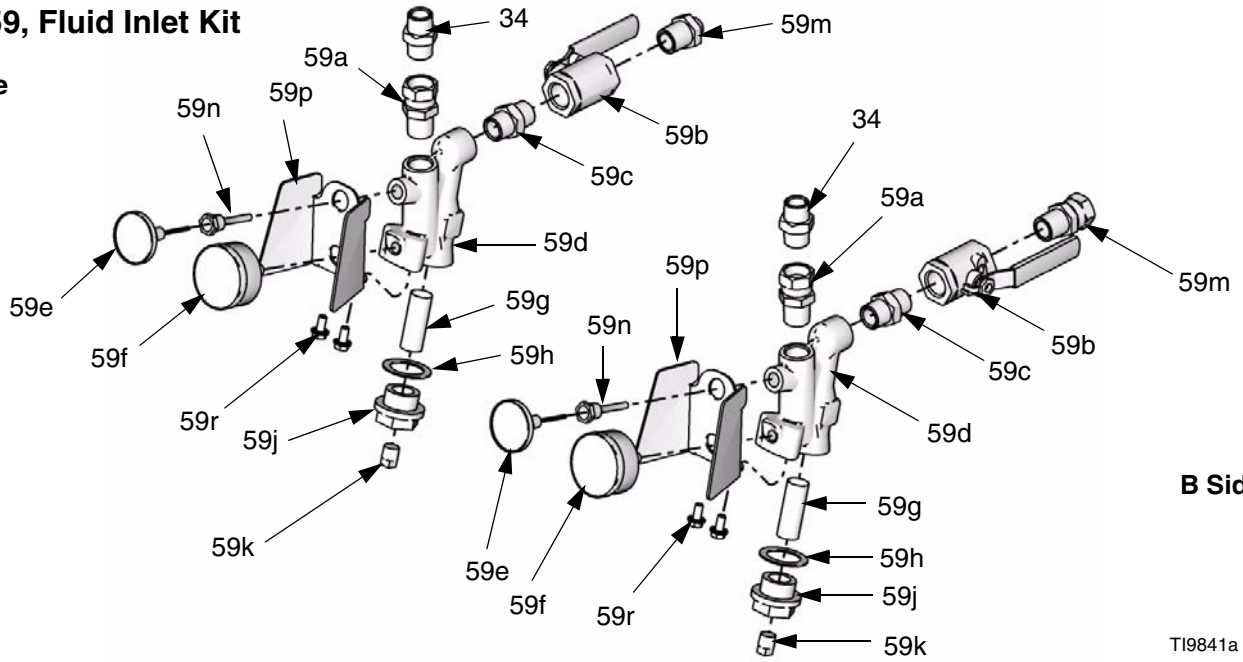

TI9841a

Ref. 110, Hydraulic Reservoir

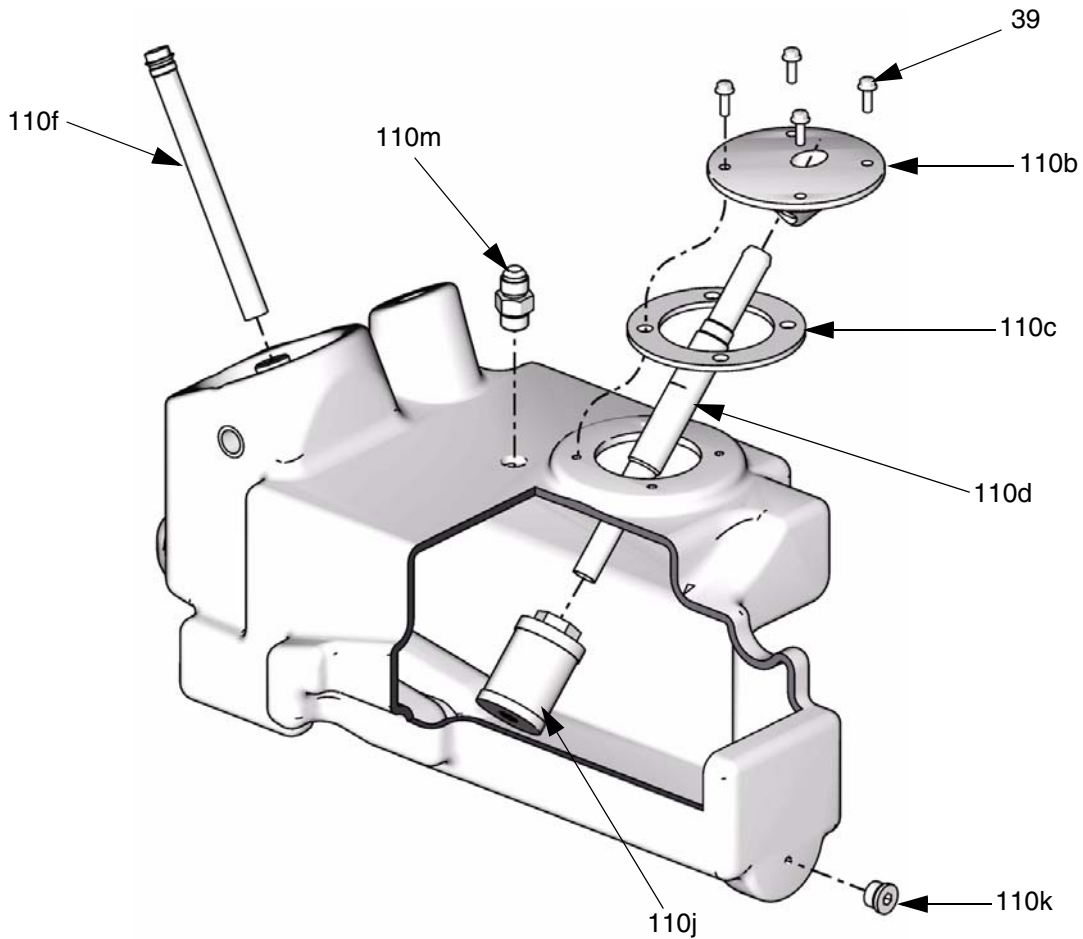

ti9840a

Parts Used on All Models

Ref	Part	Description	Qty.	Ref	Part	Description	Qty.
2		HEATER; see page 55 for part numbers	2	45▲	189930	LABEL, caution	2
3		MOTOR; see page 55 for part numbers	1	46	247844	BRACKET, reservoir, lube	1
4	245974	DISPLAY; page 64	1	47	247845	PULLEY, drive	1
5		CONTROL, temperature; see page 55 for part numbers	1	48	803889	BELT	1
6		BOARD, circuit, motor control; see page 55 for part numbers	1	49★	15B593	SHIELD, membrane switch	1
7	247823	MANIFOLD, fluid; page 66	1	50★	308212	PAD, pamphlet safety	1
8		TRANSFORMER; see page 55 for part numbers	1	51	15B775	COVER, wire access	1
9	247832	COVER, motor	1	52		COVER, heater; see page 55 for part numbers	2
10	246976	COVER, main cabinet	1	53		SCREW, machine, pan hd; 8-32 x 3/8	7
11		PUMP, proportioning; see page 55 for part numbers	1	54▲	15G280	LABEL, warning	1
13	115834	FAN, cooling	1	55	113505	NUT, KEPS, hex hd	4
14		TUBE, inlet, component A; see page 55 for part numbers	1	56	112776	WASHER, plain	2
15		TUBE, outlet, component A; see page 55 for part numbers	1	57	113802	SCREW, hex hd, flanged	8
16		TUBE, inlet, component B; see page 55 for part numbers	1	58★		STRAP, tie, wire	20
17		TUBE, outlet, component B; see page 55 for part numbers	1	59	255159	KIT, inlet, fluid; includes 59a-59r; see page 52	1
18★	247787	CABLE, harness, heater overtemp., includes 12-pin connector	1	59a		. UNION, swivel; 3/4 npt(m) x 3/4 npsm(f)	3
19	15B380	CABLE, hose, control; see manual 312064	1	59b		. VALVE, ball; 3/4 npt (fbe)	2
20	15B383	CABLE, display	1	59c		. NIPPLE; 3/4 npt	2
21★	261669	KIT, fluid temp sensor, coupler	1	59d	247503	. MANIFOLD, strainer, inlet	2
23	103181	WASHER, lock ext	1	59e	102124	. THERMOMETER, dial	2
24	15B360	GASKET, fan	1	59f	120300	. GAUGE, pressure, fluid	2
25	255047	STRAIN RELIEF, M40 thread	1	59g	180199	. ELEMENT, filter; 20 mesh (standard)	2
26		MODULE; see page 55 for part numbers	1	59h	15H200	. GASKET, strainer; PTFE	2
27	116149	SPACER	4	59j	15H199	. PLUG, strainer	2
29	117666	TERMINAL, ground	1	59k		. PLUG, pipe; 3/8 npt	2
30	C19843	SCREW, CAP, socket hd	1	59m		. UNION, swivel; 3/4 npt(m) x 1/2 npt(f); A side only	1
31	247841	SWITCH, disconnect	1	59n	15D757	. HOUSING, thermometer	2
32	247842	KNOB, operator disconnect	1	59p	253481	. GUARD, gauge	2
33	117723	SCREW, mach, slotted hd	4	59r	111800	. SCREW, cap, hex hd; 5/16-18 x 5/8 in. (16 mm)	4
34	C20487	NIPPLE, hex	2	60	111800	SCREW, cap, hex hd	35
35		COVER, heater wire; see page 55 for part numbers	2	61	247849	RESERVOIR, lube hose assy	1
36		BRACKET, heater; see page 55 for part numbers	2	62	247782	SPACER	4
37	167002	INSULATOR, heat	4	63	247850	COVER, front	1
38	117623	NUT, cap (3/8-16)	4	65	15H185	WIRE, mechanical switch cable; see page 58	1
39	113796	SCREW, flanged, hex hd	14	66★		CONNECTOR, 2 PIN, motor power; see page 55 for part numbers	1
40	115942	NUT, hex, flange head	9	67	117284	GRILL, fan guard	1
42	15K817	LABEL, fault codes	1	68		SWITCH, added pole; see page 55 for part numbers	1
44		RIVET, pop; 3/16 in. (5 mm) x 0.4 in. (10 mm)	8	74★	206995	THROAT SEAL LIQUID; 1 quart	1
				76	115836	GUARD, finger	1
				77	186494	CLIP, spring	5
				78	205447	COUPLING, hose	2
				79	054826	TUBE, PTFE; 1/4 in. (6 mm) ID; 8 ft (2.4 m)	8

Parts

Ref	Part	Description	Qty.	Ref	Part	Description	Qty.
82	15H207	BRACKET, tensioner	1	118		PULLEY, fan	1
84▲	189285	LABEL, caution	2		247856	H-40, H-50, H-XP3 models only	
85	114269	GROMMET, rubber	2		247857	H-25, H-XP2 models only	
88	247851	FITTING, reducer #5 x #8 JIC	1	119	15H512	LABEL, control	1
89	247852	FITTING, reducer #6 x #10 JIC	1	120	15H204	KNOB, pressure	1
90	111802	SCREW, cap, hex hd; 1/2-13 x 3/4 in. (19 mm)	2	122	117560	SCREW, set, socket hd	1
				125	247793	HOSE, inlet, coupled	1
92	112958	NUT, hex, flanged; 3/8-16	4	126	255029	GAUGE, pressure, fluid, panel mount	1
93	15T895	HUSE, supply	1				
94	247784	TUBE, return	1	127		ELBOW	1
96	247853	ADJUSTER, belt, tensioner	1		121320	H-40, H-50, H-XP3 models only	
97	15G816	COVER, plate, wire way	1		121321	H-25, H-XP2 models only	
98	120302	CASTER	4	129	255036	ELBOW, male	1
99	112125	PLUG, tube	2	130★	117792	GUN, grease	1
100		LABEL; see page 55 for part numbers	1	131★	117773	GREASE, lubricant	1
				132	15G782	HOSE, coupled	1
102	15H189	BOOT, wire feed through	1	133	15G784	HOSE, coupled	1
103		CONDUIT, assembly, motor power; see page 55 for part numbers	1	134	116915	DIPSTICK with breather cap	1
				135	247792	FILTER, oil, 18-23 psi bypass	1
107	119253	SUPPRESSOR, ferrite; 151 ohm	1	137		FITTING	1
110	247826	RESERVOIR, hydraulic; includes 110b-110m; see page 52	1		116793	H-40, H-50, H-XP3 models only	
					110792	H-25, H-XP2 models only	
110b	247778	. HOUSING, inlet	1	139	107156	SCREW, cap socket head	3
110c	247771	. GASKET, inlet	1	140★	115764	FITTING, npt (part of hydraulic pump assembly); H-25, H-XP2 models only	1
110d	247777	. TUBE, inlet	1				
110f	247770	. TUBE, return	1	141★	112161	SCREW (part of hydraulic pump assembly); H-25, H-XP2 models only	2
110j	116919	. FILTER, inlet	1				
110k	255032	. PLUG	1	142	112586	SCREW, cap, hex hd	2
110m	255021	. FITTING, straight	1	143	110996	NUT, hex, flange hd; 5/16-18	2
111	247822	BRACKET, motor mount	1	144	C19862	NUT, lock, hex	1
112		BRACKET, mounting, pump	1	146	247836	COVER, access	1
	247819	H-40, H-50, H-XP3 models only		147	255048	NUT, strain relief, M40 thread	1
	247830	H-25, H-XP2 models only		148★	255039	CONNECTOR, heater	1
113		PUMP, hydraulic	1	150		SCREW, set; 1/4 x 1/2 (13 mm)	2
	255019	H-40, H-50, H-XP3 models only		151	261821	CONNECTOR, wire, 6 AWG (pair)	1
	247855	H-25, H-XP2 models only		153	104373	WASHER, thrust	2
114	247821	BRACKET, reservoir, hydraulic	2				
115	247820	BRACKET, support, pumpmount	1				
116	247829	COOLER, hydraulic	1				
117		ELBOW; 1-1/16 npt(m) x 1/2 in. (13 mm) tube	1				
	255020	H-40, H-50, H-XP3 models only					
	255035	H-25, H-XP2 models only					

▲ Replacement Danger and Warning labels, tags, and cards are available at no cost.

★ Not shown.

Parts that Vary by Model

Use the following tables to find parts that vary by model. See **Parts**, starting on page 47 for parts used on all models.

H-25 and H-XP2 Models

Ref	Description	255400 H-25 8.0 kW (230V, 1 phase)	255401 H-25 8.0 kW (230V, 3 phase)	255402 H-25 8.0 kW (400V, 3 phase)	255403 H-XP2 15.3 kW (230V, 1 phase)	255404 H-XP2 15.3 kW (230V, 3 phase)	255405 H-XP2 15.3 kW (400V, 3 phase)	255406 H-25 15.3 kW (230V, 1 phase)	255407 H-25 15.3 kW (230V, 3 phase)	255408 H-25 15.3 kW (400V, 3 phase)	Qty
2	HEATER; pages 60-62	247815 (Qty. 1)	247815 (Qty. 1)	247815 (Qty. 1)	247813 (Qty. 2)	247813 (Qty. 2)	247813 (Qty. 2)	247813 (Qty. 2)	247813 (Qty. 2)	247813 (Qty. 2)	
3	MOTOR; page 51	247816	247816	247816	247816	247816	247816	247816	247816	247816	1
6	BOARD, motor control; page 49	247839	247839	247839	247839	247839	247839	247839	247839	247839	1
8	TRANSFORMER; page 49	247812	247812	247812	247812	247812	247812	247812	247812	247812	1
11	PUMP, proportioning; page 58	Model 120	Model 120	Model 120	Model 80	Model 80	Model 80	Model 120	Model 120	Model 120	1
14	TUBE, inlet, component A; page 50	15R648	15R648	15R648	15R646	15R646	15R646	15R646	15R646	15R646	1
15	TUBE, outlet, component A; page 50	15R649	15R649	15R649	15R645	15R645	15R645	15R645	15R645	15R645	1
16	TUBE, inlet, component B; page 50	15R653	15R653	15R653	15R650	15R650	15R650	15R650	15R650	15R650	1
17	TUBE, outlet, component B; page 50	15R651	15R651	15R651	15R644	15R644	15R644	15R644	15R644	15R644	1
26	MODULE, breaker; page 67	C	A	B	C	A	B	C	A	B	1
35	COVER, heater wire				247502	247502	247502	247502	247502	247502	2
36	BRACKET, heater; page 47	247831	247831	247831	247843	247843	247843	247843	247843	247843	2
52	COVER, heater	247847	247847	247847	247846	247846	247846	247846	247846	247846	2
66	CONNECTOR, 2-pin, motor power	120871	120871	120871	120871	120871	120871	120871	120871	120871	1
68	SWITCH, added pole; 400V only			117553			117553			117553	1
100	LABEL	15H194	15H194	15H194	15H195	15H195	15H195	15H194	15H194	15H194	1
103	CONDUIT, assy, motor power	247814	247814	247814	247814	247814	247814	247814	247814	247814	1

H-40 and H-XP3 Models

Ref	Description	253400 H-40 12.0 kW (230V, 1 phase)	253401 H-40 15.3 kW (230V, 3 phase)	253402 H-40 15.3 kW (400V, 3 phase)	253403 H-XP3 12.0 kW (230V, 1 phase)	253404 H-XP3 20.0 kW (230V, 3 phase)	253405 H-XP3 20.0 kW (400V, 3 phase)	253407 H-40 20.4 kW (230V, 3 phase)	253408 H-40 20.4 kW (400V, 3 phase)	Qty
2	HEATER; pages 60-62	247834	247813	247813	247834	247833	247833	247833	247833	2
3	MOTOR; page 51	247810	247785	247785	247810	247785	247785	247785	247785	1
6	BOARD, motor control; page 49	247835	247835	247835	247835	247835	247835	247835	247835	1
8	TRANS- FORMER; page 49	247786	247786	247786	247786	247786	247786	247786	247786	1
11	PUMP, proportioning; page 58	Model 120	Model 120	Model 120	Model 80	Model 80	Model 80	Model 120	Model 120	1
14	TUBE, inlet, component A; page 50	15R646	15R646	15R646	15R646	15R646	15R646	15R646	15R646	1
15	TUBE, outlet, component A; page 50	15R645	15R645	15R645	15R645	15R645	15R645	15R645	15R645	1
16	TUBE, inlet, component B; page 50	15R650	15R650	15R650	15R650	15R650	15R650	15R650	15R650	1
17	TUBE, outlet, component B; page 50	15R644	15R644	15R644	15R644	15R644	15R644	15R644	15R644	1
26	MODULE, breaker; page 67	C	D	E	C	D	E	D	E	1
35	COVER, heater wire	247502	247502	247502	247502	247502	247502	247502	247502	2
36	BRACKET, heater; page 47	247843	247843	247843	247843	247843	247843	247843	247843	2
52	COVER, heater	247846	247846	247846	247846	247846	247846	247846	247846	2
66	CONNEC- TOR, 2-pin, motor power	120871			120871					1
68	SWITCH, added pole; 400V only			117553			117553		117553	1
100	LABEL	247780	247780	247780	247781	247781	247781	247780	247780	1
103	CONDUIT, assy, motor power	247814	247790	247790	247814	247790	247790	247790	247790	1

H-50 Models

Ref	Description	253725 H-50 12.0 kW (230V, 1 phase)	253726 H-50 15.3 kW (230V, 3 phase)	253727 H-50 15.3 kW (400V, 3 phase)	256505 H-50 20.4 kW (230V, 3 phase)	256506 H-50 20.4 kW (400V, 3 phase)	Qty
2	HEATER; pages 60-62	247834	247813	247813	247833	247833	2
3	MOTOR; page 51	247810	247785	247785	247785	247785	1
6	BOARD, motor control; page 49	247835	247835	247835	247835	247835	1
8	TRANSFORMER; page 49	247786	247786	247786	247786	247786	1
11	PUMP, proportioning; page 58	Model 140	Model 140	Model 140	Model 140	Model 140	1
14	TUBE, inlet, component A; page 50	15R646	15R646	15R646	15R646	15R646	1
15	TUBE, outlet, component A; page 50	15R645	15R645	15R645	15R645	15R645	1
16	TUBE, inlet, component B; page 50	15R650	15R650	15R650	15R650	15R650	1
17	TUBE, outlet, component B; page 50	15R644	15R644	15R644	15R644	15R644	1
26	MODULE, breaker; page 67	C	D	E	D	E	1
35	COVER, heater wire	247502	247502	247502	247502	247502	2
36	BRACKET, heater; page 47	247843	247843	247843	247843	247843	2
52	COVER, heater	247846	247846	247846	247846	247846	2
66	CONNECTOR, 2-pin, motor power	120871					1
68	SWITCH, added pole; 400V only			117553		117553	1
100	LABEL	256509	256509	256509	256509	256509	1
103	CONDUIT, assy, motor power	247814	247790	247790	247790	247790	1

Sub Assemblies

Proportioner Assembly

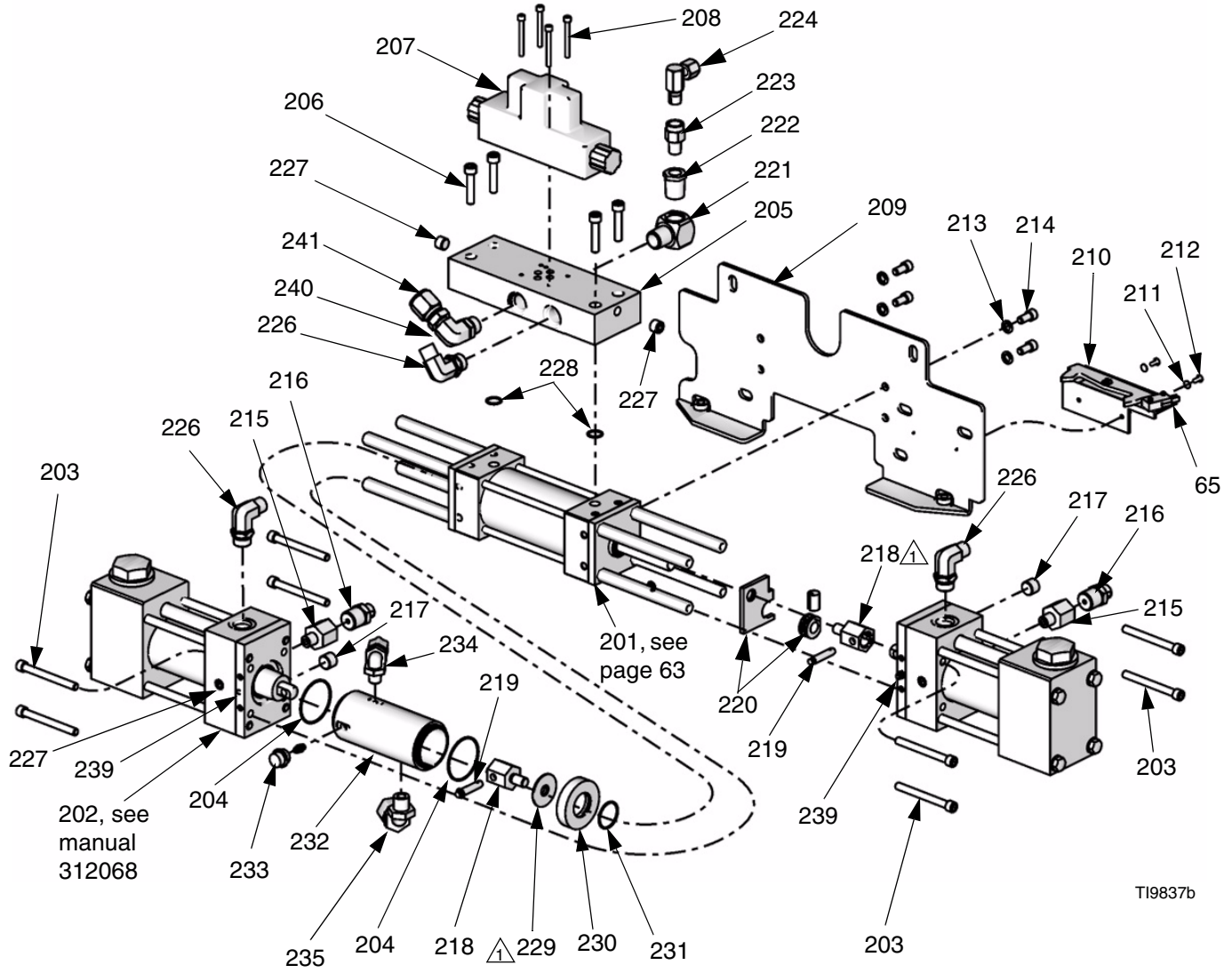

\triangle Torque to 10-15 ft-lb (13.6 - 20.3 N•m).

Proportioner Assembly

Ref	Part	Description	Qty.	Ref	Part	Description	Qty.
				222	100206	BUSHING	1
201	295027	CYLINDER, hydraulic, w/spacers; see page 63 for parts	1	223	15H524	ACCUMULATOR, pressure;1/4 npt	1
202		PUMP; see manual 312068	2	224	155541	FITTING, union, swivel, 90 degrees	1
203	295824	SCREW, socket hd; 5/16-24 x 3 in. (76 mm)	8	226	121312	ELBOW; 3/4 SAE-ORB x 1/2 in. JIC	3
204	106258	O-RING	2	227	295225	PLUG, pipe, flush	4
205	298040	MANIFOLD, hydraulic	1	228	112793	O-RING	2
206	113467	SCREW, socket hd	4	229	295852	NUT	1
207	120299	VALVE, directional, hydraulic	1	230*		ADAPTER, lube, cylinder	1
208	C19986	SCREW, socket hd	4	231	177156	O-RING	1
209	247817	BRACKET, mounting	1	232*		CYLINDER, lube	1
210	247818	SWITCH, reversing	1	233	295829	PLUG; 3/8 mpt x 0.343 in.	1
211	157021	WASHER, lock	2	234	295826	ELBOW, 90 degree; 1/4 npt(m) x 3/8 in. (9.5 mm) OD tube	1
212		SCREW, pan hd; 8-32 x 3/8	2	235	295397	ELBOW; 3/4 npt(m) x 1/2 in. (13 mm) OD tube	1
213	100214	WASHER, lock	4	239	295229	FITTING, grease; 1/4-28	2
214	108751	SCREW, socket hd	4	240	255037	ELBOW; 3/4 npt(f)	1
215	159842	ADAPTER	2	241	255038	CONNECTOR	1
216	248187	HOUSING, rupture, disc; kit, see manual 309969	2	242★	15H184	WIRE, bidirectional cable assy	1
217	M70430	SCREW, socket hd; 1/4-28 x 0.19	2	243	15H253	HOSE, gauge, hydraulic, 3000 psi; shown on page 50	1
218	261864	CLEVIS, hex	2	244★	296607	TOOL, clevis pin, extractor	1
219	296653	PIN, clevis	2				
220	261862	KIT, activator and bushing	1			★ <i>Not shown.</i>	
221	158683	ELBOW, 90 degree	1			* <i>Parts available in Kit 261863.</i>	

10.2 kW and 6.0 kW Heaters

(Two Per Machine)

Parts 247833 and 247834

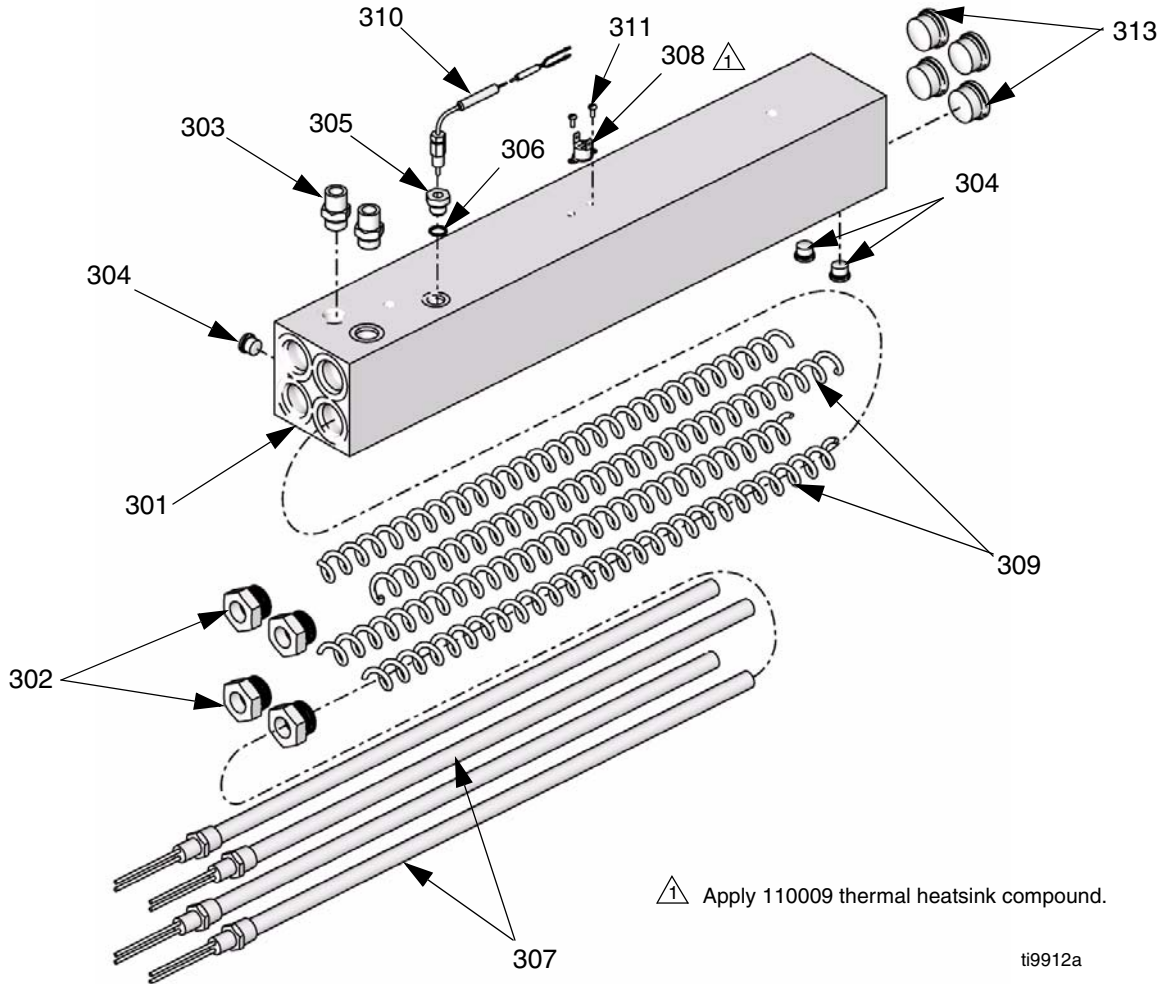

⚠ Apply 110009 thermal heatsink compound.

ti9912a

Ref	Part	Description	Qty.	Ref	Part	Description	Qty.
				308	15B137	SWITCH, overtemperature	1
				309	15B135	MIXER, immersion heater	4
301		HOUSING, heater	1	310	117484	SENSOR	1
302	15H302	FITTING, reducer	4	311	100518	SCREW, machine, pan hd	2
303	121309	ADAPTER, 3/4 SAE-ORB x 1/2 in. JIC	2	313	15H305	PLUG, hollow	4
304	15H304	PLUG	4				
305	15H306	ADAPTER, thermocouple	1				
306	120336	O-RING; fluoroelastomer	1				
307		HEATER, immersion	4				
	15B138	2550W; 10.4 kW heater only					
	15B140	1500 W; 6.0 kW heater only					

8.0 kW Dual Zone Heater

(One Per Machine)

Part 247815

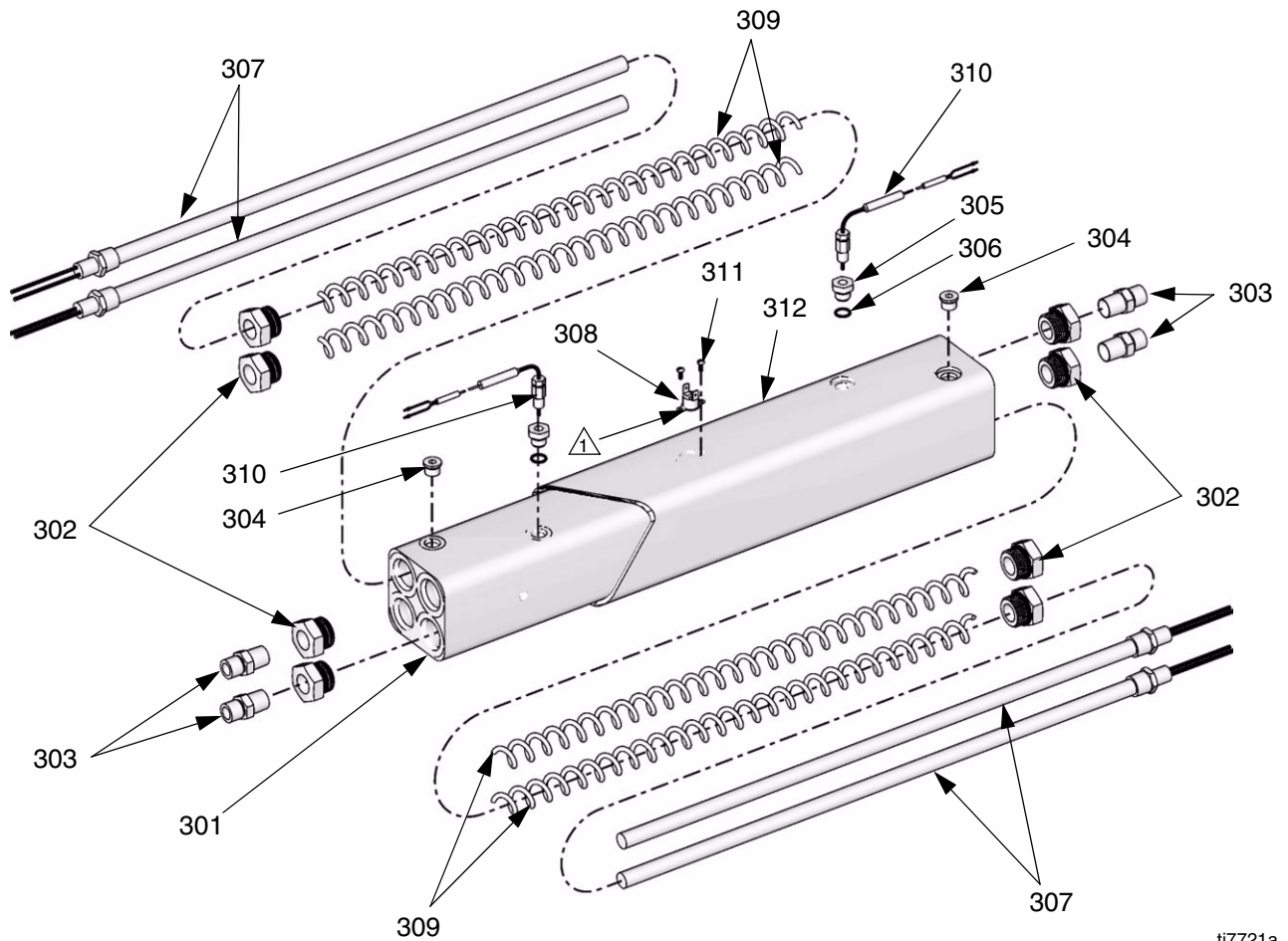

ti7721a

 Apply 110009 thermal heatsink compound.

Ref.	Part	Description	Qty.	Ref.	Part	Description	Qty.
301		HOUSING, heater	1	308	15B137	SWITCH, over temperature	1
302	15H302	FITTING, reducer	8	309	15B135	MIXER, immersion heater	4
303	121319	ADAPTER, 1/2 npt(m) x 1/2 in. JIC	4	310	117484	SENSOR	2
304	15H304	PLUG	2	311	100518	SCREW, machine, pan hd	2
305	15H306	ADAPTER, thermocouple	2	312	15H205	INSULATOR	1
306	120336	O-RING; fluoroelastomer	2				
307	15B139	HEATER, immersion; 2000 W	4				

7.65 kW Single Zone Heater

(Two Per Machine)

Part 247813

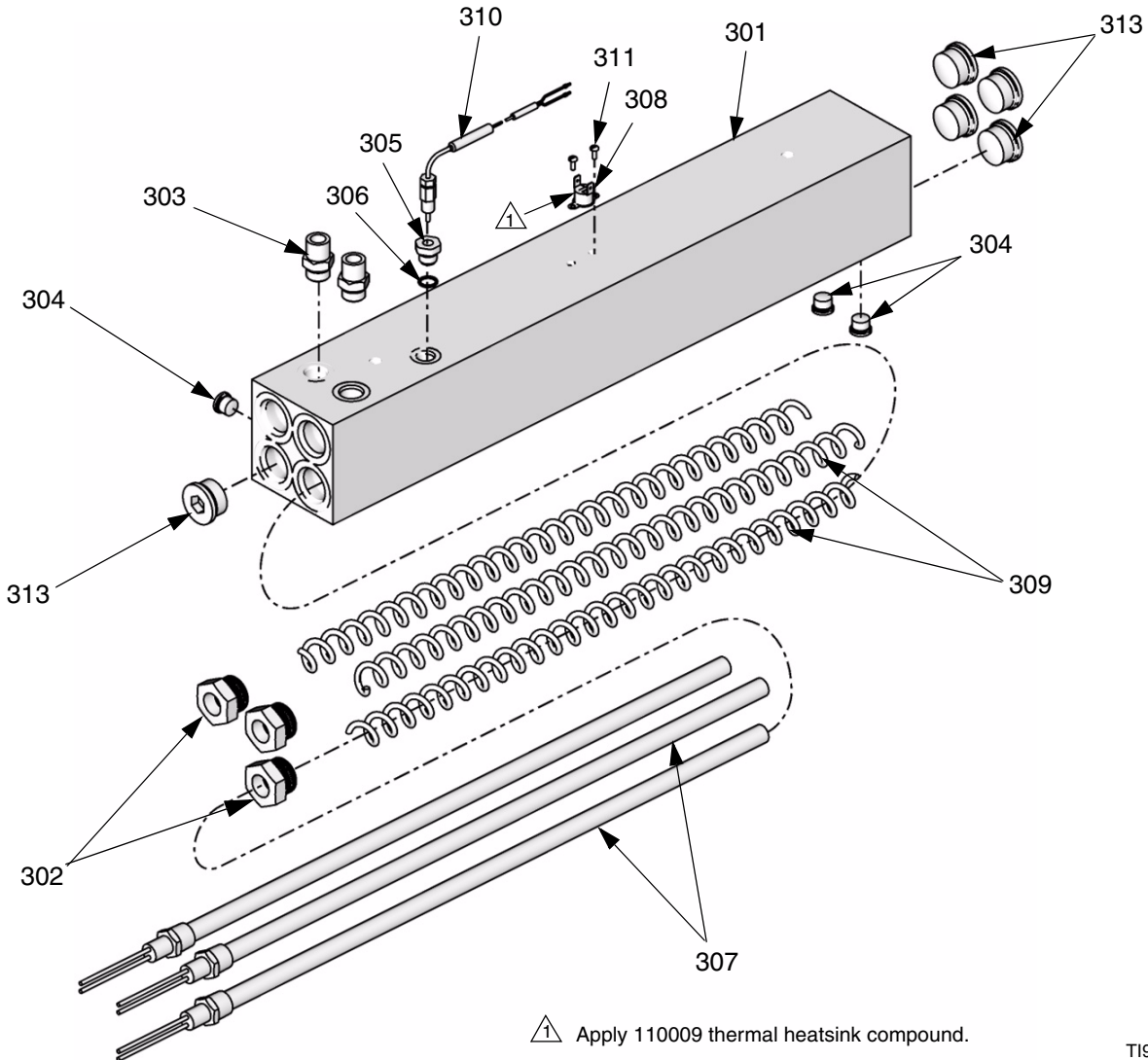

 Apply 110009 thermal heatsink compound.

T19842a

Ref.	Part	Description	Qty	Ref.	Part	Description	Qty
301		HOUSING, heater	1	308	15B137	SWITCH, overtemperature	1
302	15H302	FITTING, reducer	3	309	15B135	MIXER, immersion heater	3
303	121309	ADAPTER, 3/4 SAE-ORB x 1/2 in. JIC	2	310	117484	SENSOR	1
304	15H304	PLUG	3	311	100518	SCREW, machine, pan hd	2
305	15H306	ADAPTER, thermocouple	1	313	15H305	PLUG, hollow	5
306	120336	O-RING; fluoroelastomer	1				
307	15B138	HEATER, immersion; 2550 W	3				

Hydraulic Cylinder

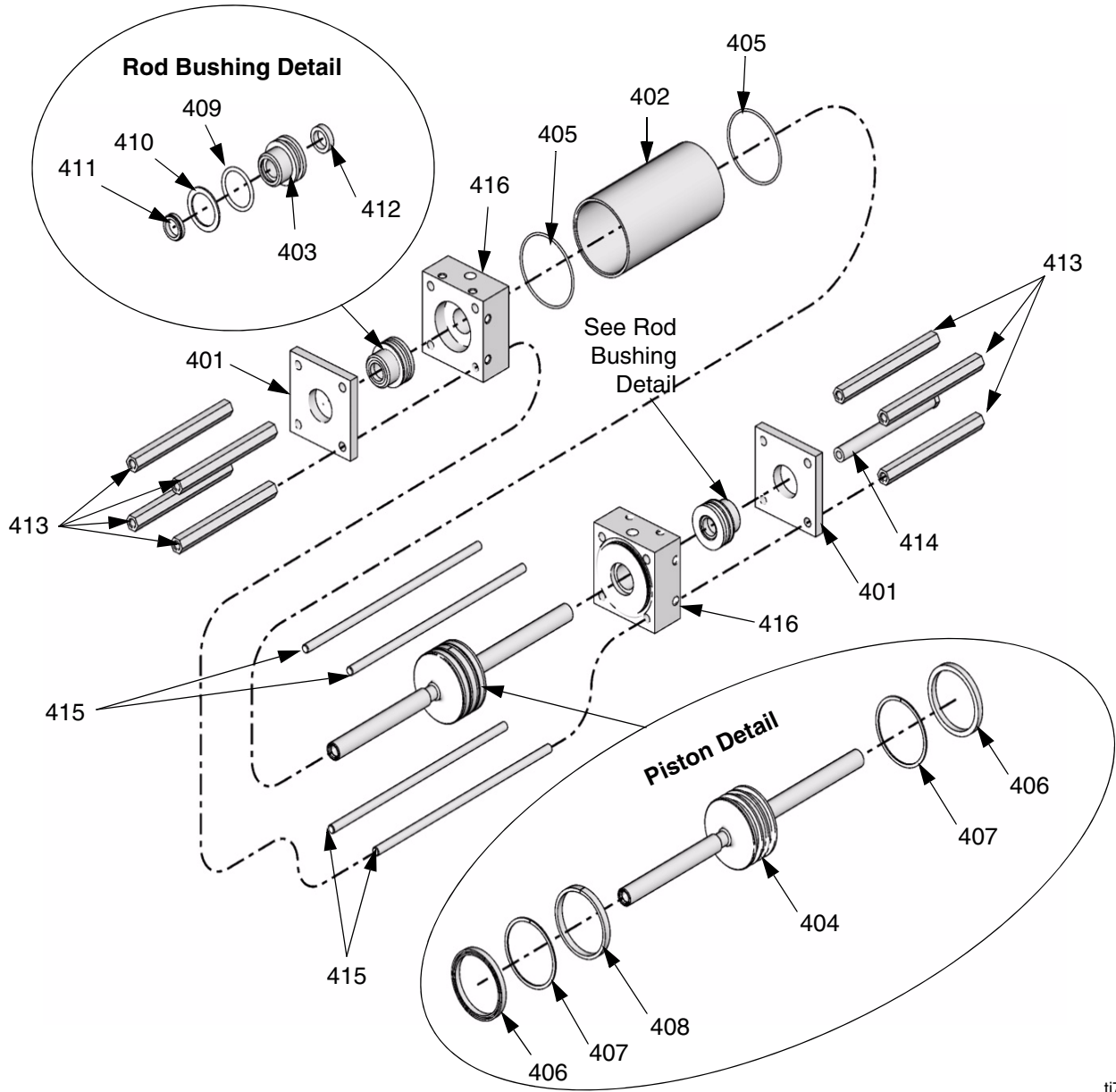

ti7727a

Ref.	Part	Description	Qty.	Ref.	Part	Description	Qty.
401	295029	PLATE, retainer	2	409	158776	O-RING	2
402	295030	CYLINDER	1	410	295644	RING, backup	2
403	295031	BUSHING, rod	2	411	295645	WIPER, rod	2
404	296642	PISTON	1	412	296644	SEAL, shaft	2
405	295640	O-RING	2	413	295032	SPACER, proportioning pump	7
406	295641	U-CUP	2	414	261861	SPACER, reverse switch	1
407	295642	RING, backup	2	415	295034	ROD, tie	4
408	296643	RING, wear	1	416	295035	BLOCK, port	2

Display

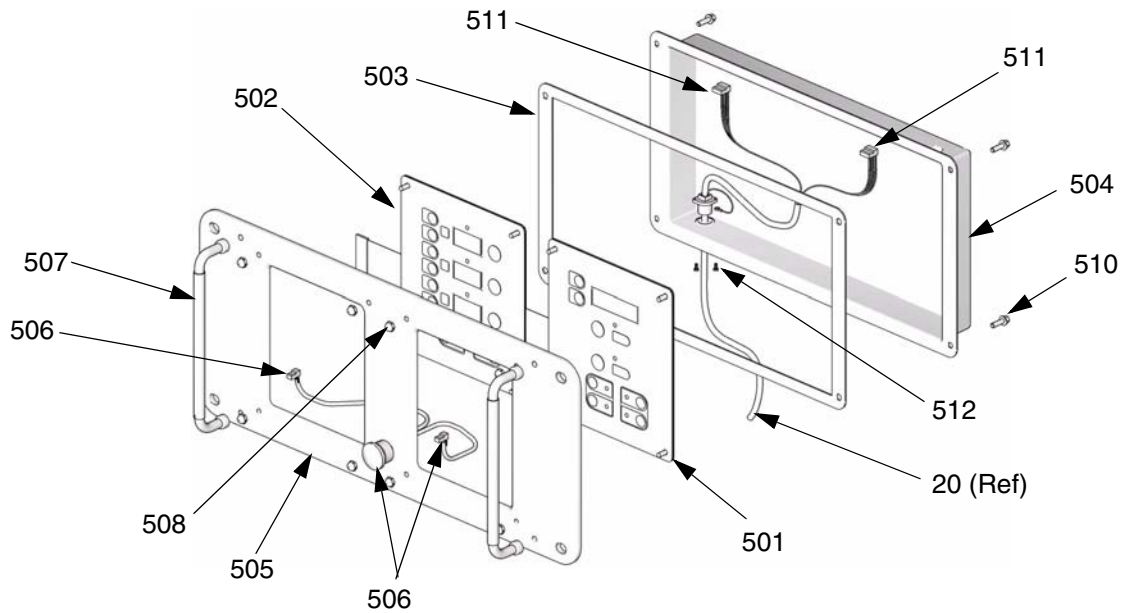

ti2574a

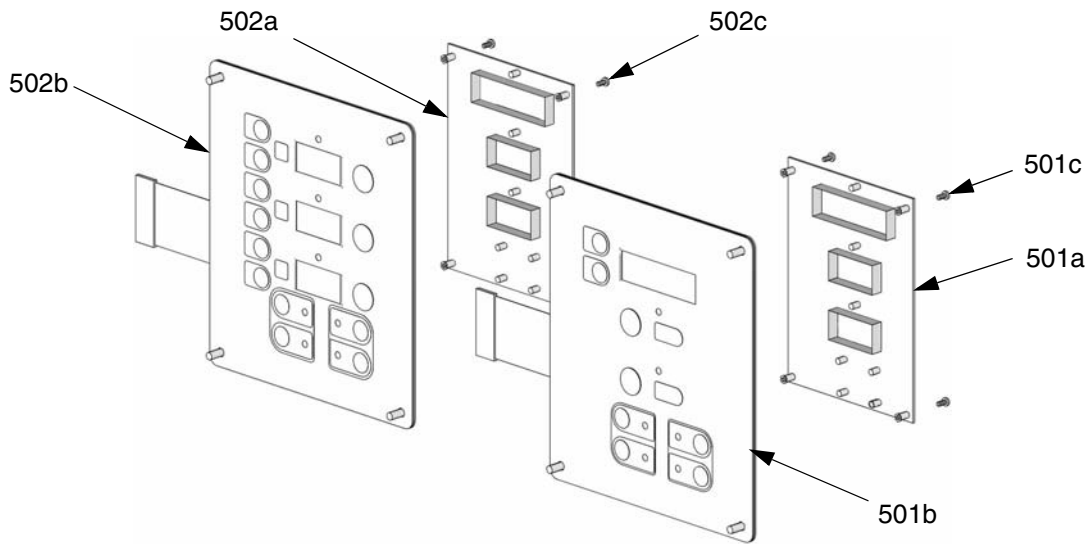

ti3172a

Ref.	Part	Description	Qty.	Ref.	Part	Description	Qty.
501	245978	DISPLAY, pressure; includes 501a-501c	1	505	15B291	PLATE	1
501a	246130	.BOARD, circuit	1	506	246287	HARNESS, wire, red stop button	1
501b	246478	.SWITCH, membrane	1	507	117499	HANDLE	2
501c	112324	.SCREW	4	508	117523	NUT, cap; 10-24	8
502	245977	DISPLAY, temperature; includes 502a-502c	1	510		SCREW, machine, pan-hd; M5 x 0.8; 16 mm	4
502a	246130	.BOARD, circuit	1	511	15B386	CABLE, display	1
502b	246479	.SWITCH, membrane	1	512	195853	SCREW, machine; M2.5 x 6	2
502c	112324	.SCREW	4				
503	15B293	GASKET	1				
504	15B292	COVER	1				

Temperature Control

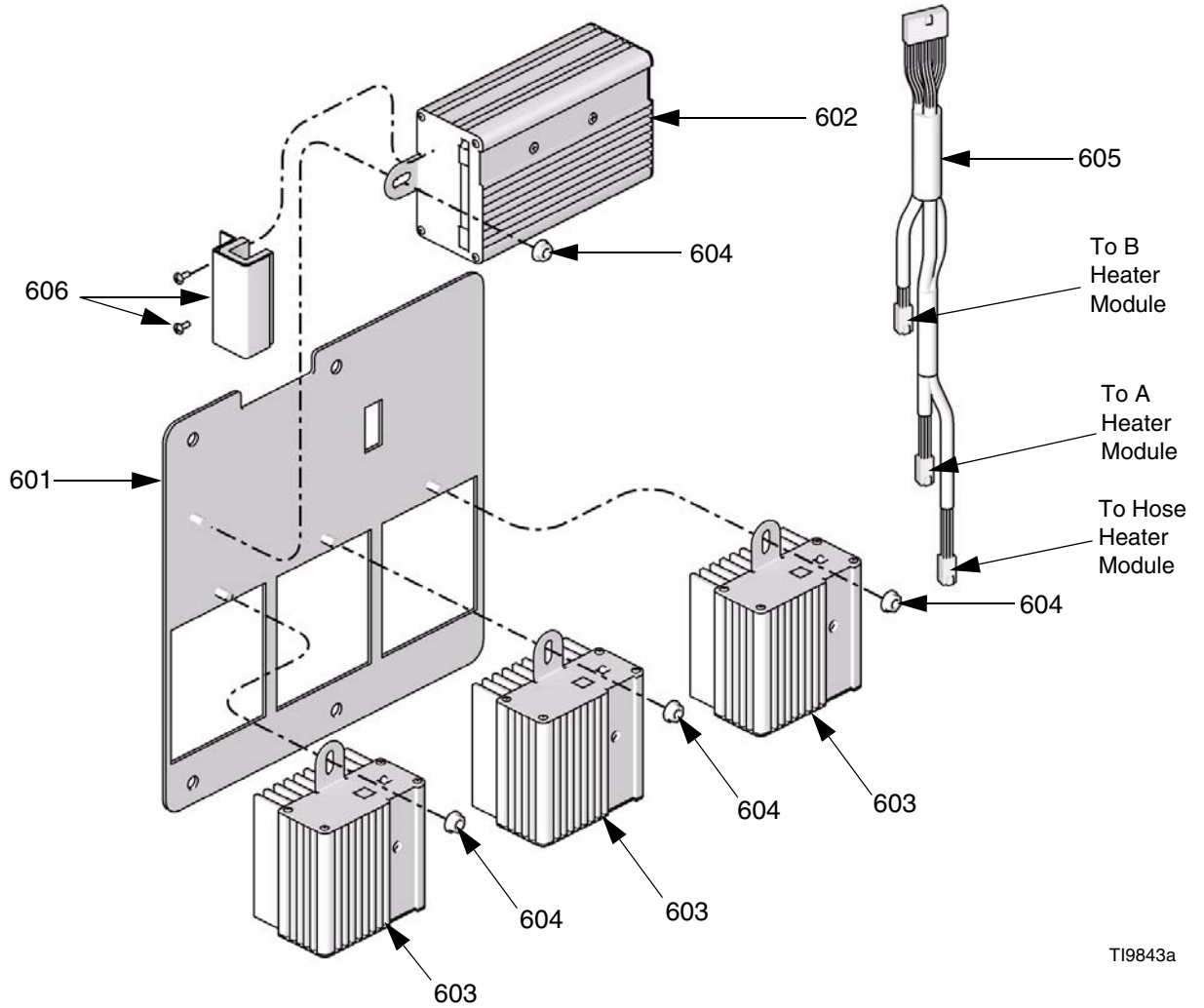

TI9843a

Ref.	Part	Description	Qty.
601	247772	PANEL, module mounting	1
602	247827	HOUSING, control module	1
603	247828	HOUSING, heater module	3
604	115942	NUT, hex	4
605	247801	CABLE, communication	1
606	247825	KIT, cover, connector with screws	1

Fluid Manifold

- ① Torque to 355-395 in-lb (40.1-44.6 N•m).
- ② Apply sealant (113500) to threads.
- ③ Valve must be closed with handle position as shown on drawing.

** Apply PTFE tape or thread sealant to tapered threads.

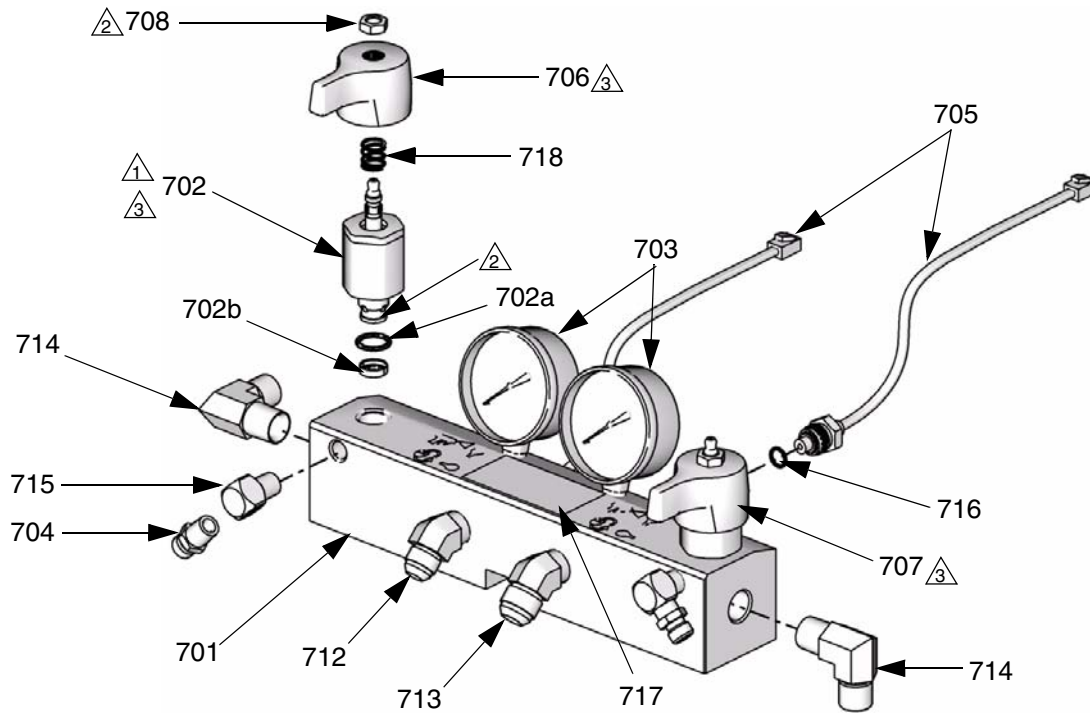

TI9839a

Ref.	Part	Description	Qty.	Ref.	Part	Description	Qty.
701	247837	MANIFOLD, fluid	1	714	121312	ELBOW, 90 degrees	2
702†	247824	VALVE, drain cartridge	2	715	100840	ELBOW, street; 1/4 npsm x 1/4 npt	2
702a†	158674	. O-RING	1	716	111457	O-RING, PTFE	2
702b†	247779	. SEAL, seat, valve	1	717▲	189285	LABEL, caution	1
703	102814	GAUGE, pressure, fluid	2	718†	150829	SPRING, compression	2
704	162453	FITTING, 1/4 npsm x 1/4 npt	2	▲ Replacement Warning labels, signs, tags, and cards are available at no cost.			
705	246123	TRANSDUCER, pressure, control	2	† Included in the following complete valve kits*: ISO Valve Kit (left/red handle) 255149. Resin Valve Kit (right/blue handle) 255150. Valve Set Kit (both handles and grease gun) 255148.			
706	247788	HANDLE, red	1	* Complete valve kits also include thread sealant. (Purchase kits separately).			
707	247789	HANDLE, blue	1				
708†	112309	NUT, hex, jam	2				
712	117556	NIPPLE, #8 JIC x 1/2 npt	1				
713	117557	NIPPLE, #10 JIC x 1/2 npt	1				

Circuit Breaker Modules

A - 230V, 3 Phase Circuit Breaker Modules

For wiring and cable connections, refer to electrical diagrams manual 312064, supplied. See page 70 for parts.

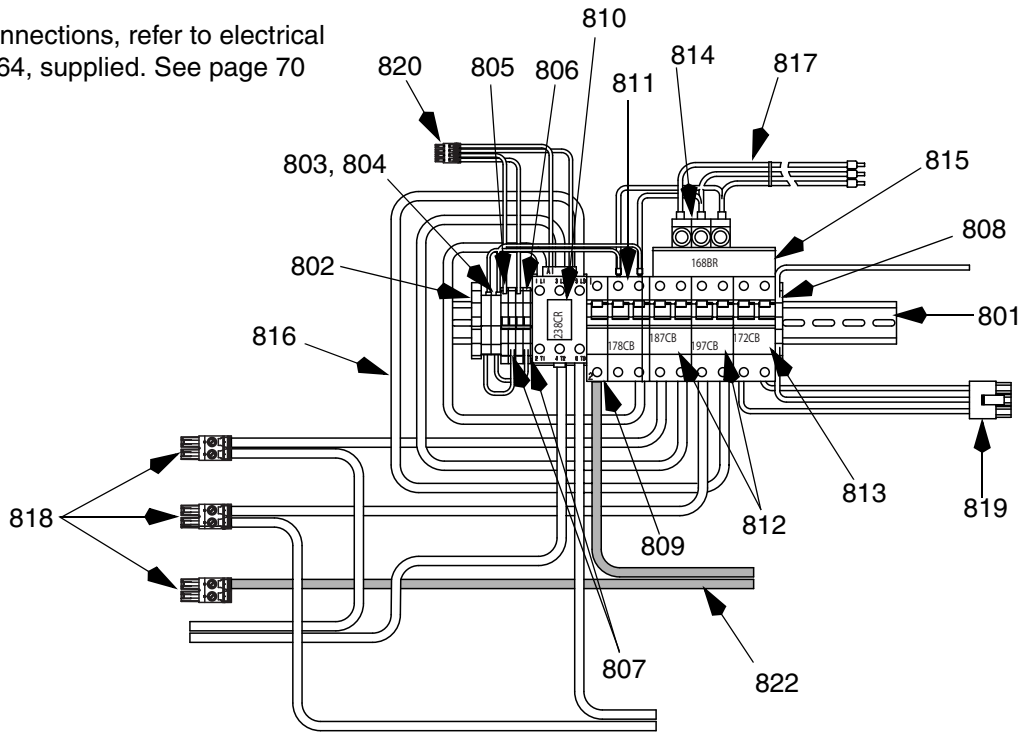

B - 400V, 3 Phase Circuit Breaker Modules

For wiring and cable connections, refer to electrical diagrams manual 312064, supplied. See page 70 for parts.

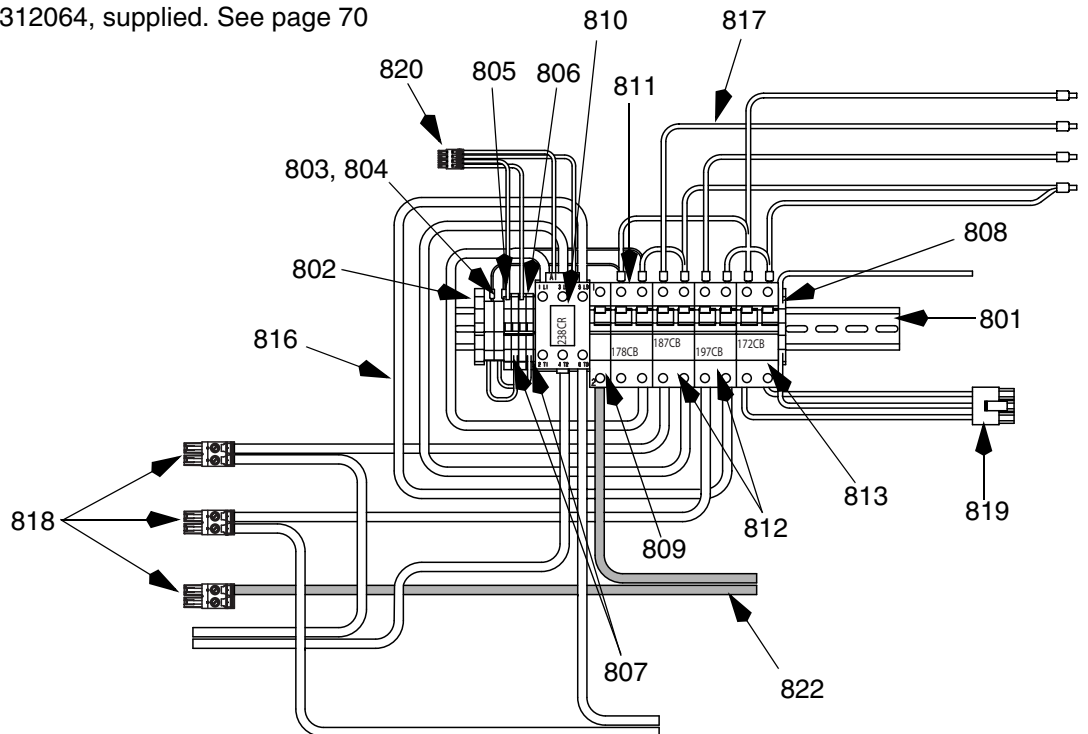

C - 230V, 1 Phase Circuit Breaker Modules

For wiring and cable connections, refer to electrical diagrams manual 312064, supplied. See page 70 for parts.

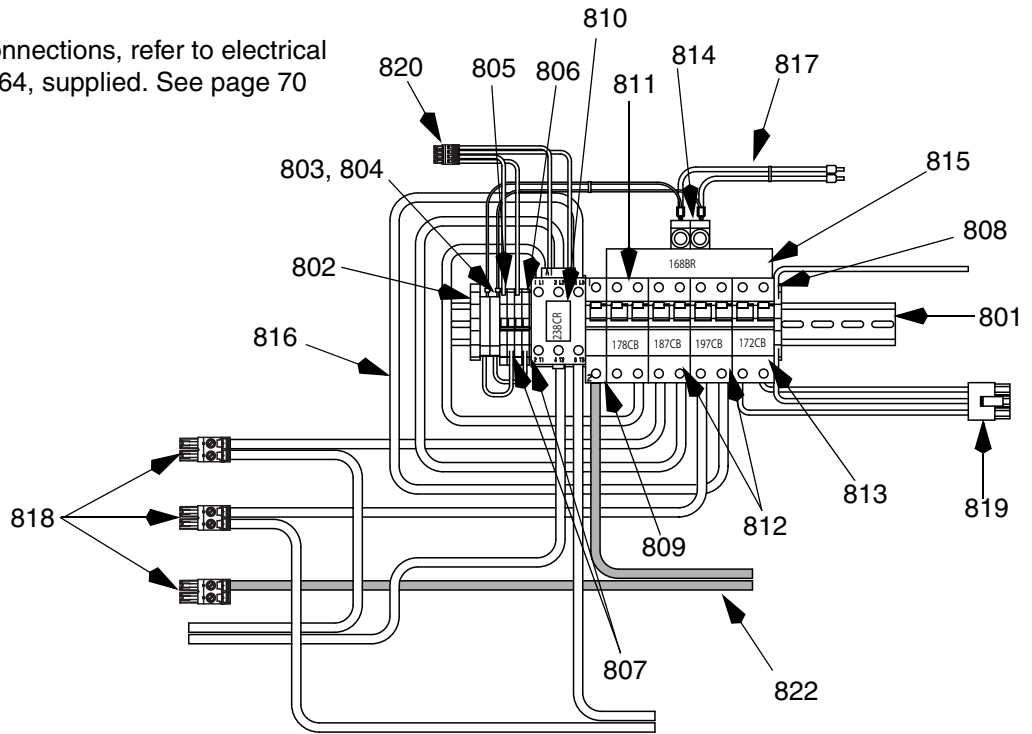

D - 230V, 3 Phase Circuit Breaker Modules

For wiring and cable connections, refer to electrical diagrams manual 312064, supplied. See page 70 for parts.

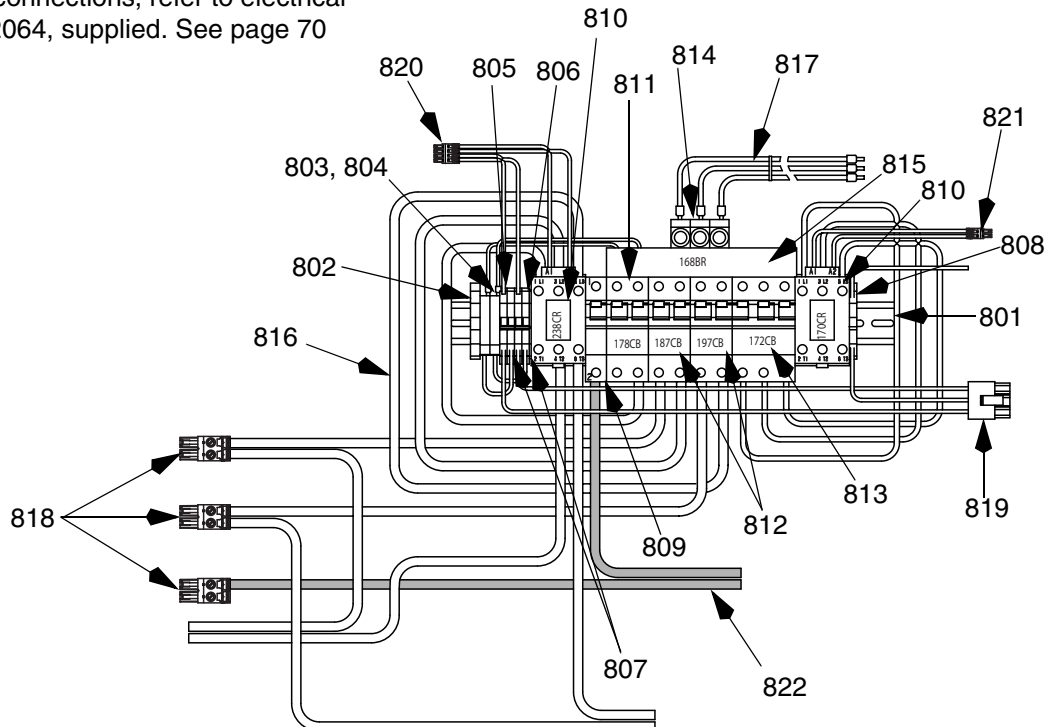

E - 400V, 3 Phase Circuit Breaker Modules

 For wiring and cable connections, refer to electrical diagrams manual 312064, supplied. See page 70 for parts.

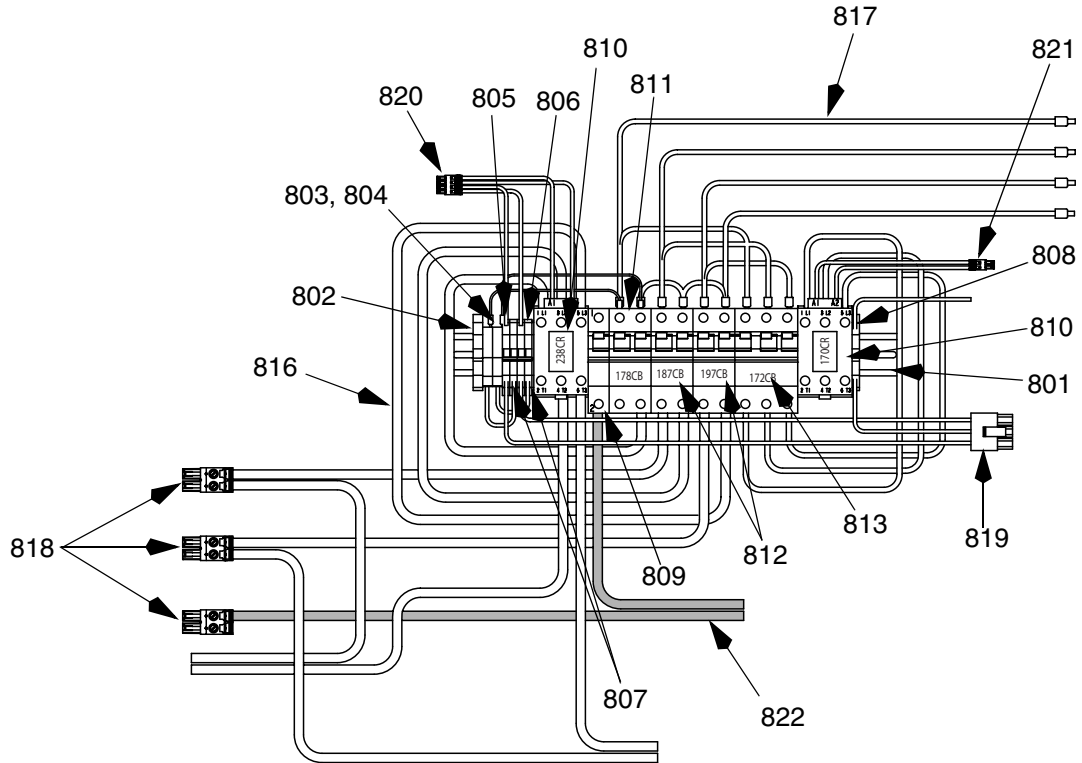

Circuit Breaker Modules Parts List

Ref.	Description	Breaker Modules					Qty
		A 230V, 3 phase	B 400V, 3 phase	C 230V, 1 phase	D 230V, 3 phase	E 400V, 3 phase	
801	RAIL, mounting	255028	255028	255028	255028	255028	1
802	CLAMP, block, end	255045	255045	255045	255045	255045	1
803	HOLDER, fuse terminal, block	255043	255043	255043	255043	255043	2
804	FUSE	255023	255023	255023	255023	255023	2
805	TERMINAL, block	255042	255042	255042	255042	255042	4
807	BRIDGE, plug in, jumper	255044	255044	255044	255044	255044	2
808	BLOCK, terminal ground	255046	255046	255046	255046	255046	1
809	BREAKER, 1 pole, 50A	255026	255026	255026	255026	255026	1
810	CONTACTOR, relay, 65A	255022	255022	255022			1
	CONTACTOR, relay, 65A				255022	255022	2
811	BREAKER, 2 phase, 40A	247768	247768	247768	247768	247768	1
812	BREAKER, 2 phase, 25A	*255050	*255050	*255050			2
	BREAKER, 2 phase, 40A	†247768	†247768	†*247768			2
	BREAKER, 2 phase, 50A				120579	120579	2
813	BREAKER, 2 phase, 20A	255049	255049	*†255049			1
	BREAKER, 3 pole, 20A				255025	255025	1
	BREAKER, 2 phase, 30A			※255041			1
814	CONNECTOR, power lug	117679			117679		3
	CONNECTOR, power lug			117679			2
815	BAR, power buss, 3 phase	117805					1
	BAR, power buss, 1 phase			117678			1
	BAR, power buss, 3 phase, 3x3				255024		1
816	CABLE, harness lower	247802	247802	247802	247803	247803	1
817	CABLE, harness upper	247805	247806	247804	247808	247807	1
818	CONNECTOR, 2 pin large	255027	255027	255027	255027	255027	3
819	CONNECTOR, 3 pin	120895	120895	120895	120895	120895	1
820	CONNECTOR, 4 pin	255031	255031	255031	255031	255031	1
821	CONNECTOR, 2 pin small				255030	255030	1
822	CABLE, harness, hose wire	247791	247791	247791	247791	247791	1

* 8 kW H-25 models only.

† 15.3 kW H-25, H-XP2, H-40, H-50 models only.

※ 12kW H-40, H-50 models only.

Dimensions

Dimension	in. (mm)	Dimension	in. (mm)
A (height)	55.0 (1397)	F (side mounting holes)	16.25 (413)
B (width)	39.6 (1006)	G (mounting post inner diameter)	0.44 (11)
C (depth)	18.5 (470)	H (front mounting post height)	2.0 (51)
D (front mounting holes)	29.34 (745)	J (rear mounting post height)	3.6 (92)
E (rear mounting holes)	33.6 (853)		

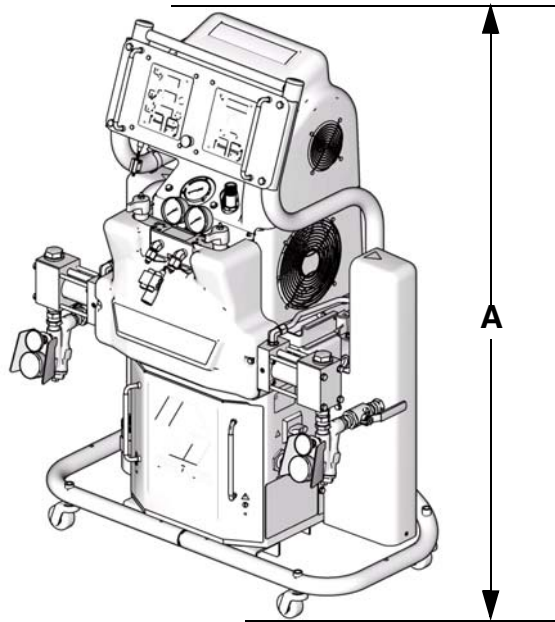

ti9830a

Top View

Side View

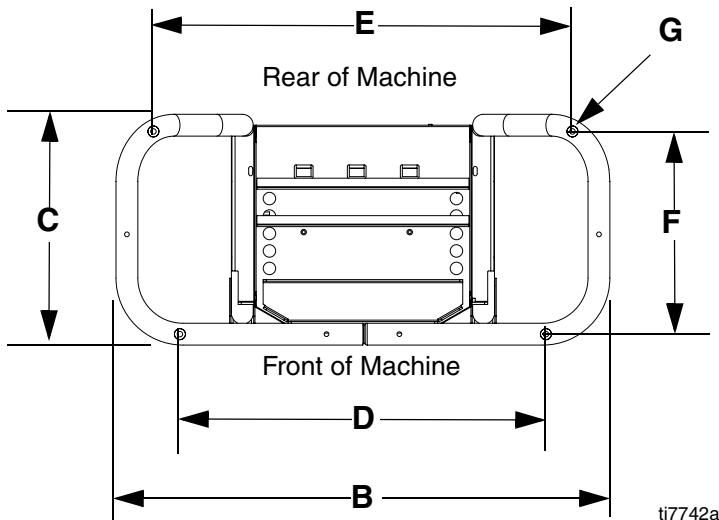

ti7742a

Detail of mounting post height, to correctly size mounting bolts

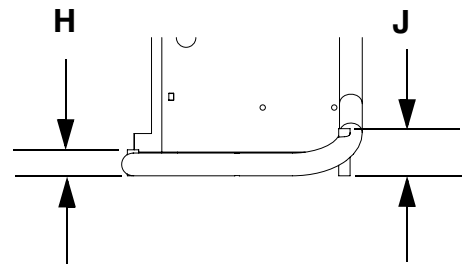

ti7743a

Technical Data

Category	Data
Maximum Fluid Working Pressure	Models H-25 and H-40: 2000 psi (13.8 MPa, 138 bar) Model H-50 1 phase: 1700 psi (11.7 MPa, 11.7 bar) Model H-50 3 phase: 2000 psi (13.8 MPa, 138 bar) Models H-XP2 and H-XP3: 3500 psi (24.1 MPa, 241 bar)
Fluid:Oil Pressure Ratio	Models H-25 and H-40: 1.91:1 Model H-50: 1.64:1 Models H-XP2 and H-XP3: 2.79:1
Fluid Inlets	Component A (ISO): 1/2 npt(f), 250 psi (1.75 MPa, 17.5 bar) maximum Component B (RES): 3/4 npt(f), 250 psi (1.75 MPa, 17.5 bar) maximum
Fluid Outlets	Component A (ISO): #8 (1/2 in.) JIC, with #5 (5/16 in.) JIC adapter Component B (RES): #10 (5/8 in.) JIC, with #6 (3/8 in.) JIC adapter
Fluid Circulation Ports	1/4 npsm(m), with plastic tubing, 250 psi (1.75 MPa, 17.5 bar) maximum
Maximum Fluid Temperature	190°F (88°C)
Maximum Output (10 weight oil at ambient temperature)	Model H-25: 22 lb/min (10 kg/min) (60 Hz) Model H-XP2: 1.5 gpm (5.7 liter/min) (60 Hz) Model H-50: 52 lb/min (24 kg/min) (60 Hz) Model H-40: 45 lb/min (20 kg/min) (60 Hz) Model H-XP3: 2.8 gpm (10.6 liter/min) (60 Hz)
Output per Cycle (A and B)	Models H-25 and H-40: 0.063 gal. (0.23 liter) Model H-50: 0.073 gal. (0.28 liter) Models H-XP2 and H-XP3: 0.042 gal. (0.16 liter)
Line Voltage Requirement	230V 1 phase and 230V 3 phase units: 195-264 Vac, 50/60 Hz 400V 3 phase units: 338-457 Vac, 50/60 Hz
Amperage Requirement	See Models , page 3.
Heater Power (A and B heaters total, no hose)	See Models , page 3.
Hydraulic reservoir capacity	3.5 gal. (13.6 liters)
Recommended hydraulic fluid	Citgo A/W Hydraulic Oil, ISO Grade 46
Sound power, per ISO 9614-2	90.2 dB(A)
Sound pressure, 1 m from equipment	82.6 dB(A)
Weight	Units with 8.0 kW Heaters: 535 lb (243 kg) Units with 12.0 kW Heaters: 597 lb (271 kg) Units with 15.3 kW Heaters (H-25/H-XP2 models):562 lb (255 kg) Units with 15.3 kW Heaters (H-40/H-XP3/H-50 models): 597 lb (271 kg) Units with 20.4 kW Heaters: 597 lb (271 kg)
Wetted Parts	Aluminum, stainless steel, zinc-plated carbon steel, brass, carbide, chrome, fluoroelastomer, PTFE, ultra-high molecular weight polyethylene, chemically resistant o-rings

All other brand names or marks are used for identification purposes and are trademarks of their respective owners.

Graco Standard Warranty

Graco warrants all equipment referenced in this document which is manufactured by Graco and bearing its name to be free from defects in material and workmanship on the date of sale to the original purchaser for use. With the exception of any special, extended, or limited warranty published by Graco, Graco will, for a period of twelve months from the date of sale, repair or replace any part of the equipment determined by Graco to be defective. This warranty applies only when the equipment is installed, operated and maintained in accordance with Graco's written recommendations.

This warranty does not cover, and Graco shall not be liable for general wear and tear, or any malfunction, damage or wear caused by faulty installation, misapplication, abrasion, corrosion, inadequate or improper maintenance, negligence, accident, tampering, or substitution of non-Graco component parts. Nor shall Graco be liable for malfunction, damage or wear caused by the incompatibility of Graco equipment with structures, accessories, equipment or materials not supplied by Graco, or the improper design, manufacture, installation, operation or maintenance of structures, accessories, equipment or materials not supplied by Graco.

This warranty is conditioned upon the prepaid return of the equipment claimed to be defective to an authorized Graco distributor for verification of the claimed defect. If the claimed defect is verified, Graco will repair or replace free of charge any defective parts. The equipment will be returned to the original purchaser transportation prepaid. If inspection of the equipment does not disclose any defect in material or workmanship, repairs will be made at a reasonable charge, which charges may include the costs of parts, labor, and transportation.

THIS WARRANTY IS EXCLUSIVE, AND IS IN LIEU OF ANY OTHER WARRANTIES, EXPRESS OR IMPLIED, INCLUDING BUT NOT LIMITED TO WARRANTY OF MERCHANTABILITY OR WARRANTY OF FITNESS FOR A PARTICULAR PURPOSE.

Graco's sole obligation and buyer's sole remedy for any breach of warranty shall be as set forth above. The buyer agrees that no other remedy (including, but not limited to, incidental or consequential damages for lost profits, lost sales, injury to person or property, or any other incidental or consequential loss) shall be available. Any action for breach of warranty must be brought within two (2) years of the date of sale.

GRACO MAKES NO WARRANTY, AND DISCLAIMS ALL IMPLIED WARRANTIES OF MERCHANTABILITY AND FITNESS FOR A PARTICULAR PURPOSE, IN CONNECTION WITH ACCESSORIES, EQUIPMENT, MATERIALS OR COMPONENTS SOLD BUT NOT MANUFACTURED BY GRACO. These items sold, but not manufactured by Graco (such as electric motors, switches, hose, etc.), are subject to the warranty, if any, of their manufacturer. Graco will provide purchaser with reasonable assistance in making any claim for breach of these warranties.

In no event will Graco be liable for indirect, incidental, special or consequential damages resulting from Graco supplying equipment hereunder, or the furnishing, performance, or use of any products or other goods sold hereto, whether due to a breach of contract, breach of warranty, the negligence of Graco, or otherwise.

FOR GRACO CANADA CUSTOMERS

The Parties acknowledge that they have required that the present document, as well as all documents, notices and legal proceedings entered into, given or instituted pursuant hereto or relating directly or indirectly hereto, be drawn up in English. Les parties reconnaissent avoir convenu que la rédaction du présente document sera en Anglais, ainsi que tous documents, avis et procédures judiciaires exécutés, donnés ou intentés, à la suite de ou en rapport, directement ou indirectement, avec les procédures concernées.

Graco Information

TO PLACE AN ORDER, contact your Graco distributor or call to identify the nearest distributor.

Phone: 612-623-6921 **or Toll Free:** 1-800-328-0211, **Fax:** 612-378-3505

*All written and visual data contained in this document reflects the latest product information available at the time of publication.
Graco reserves the right to make changes at any time without notice.*

This manual contains English. MM 312063

Graco Headquarters: Minneapolis
International Offices: Belgium, China, Japan, Korea

GRACO INC. P.O. BOX 1441 MINNEAPOLIS, MN 55440-1441

Copyright 2007, Graco Inc. is registered to I.S. EN ISO 9001

www.graco.com
Revised 10/2008