

REACTOR®

312066V

EN

Electric, Heated, Plural Component Proportioner. For spraying polyurethane foam and polyurea coatings. For professional use only.

Not approved for use in European explosive atmosphere locations.



Important Safety Instructions

Read all warnings and instructions in this manual. Save these instructions.

See page 3 for model information, including maximum working pressure and approvals.

Model E-XP1 Shown

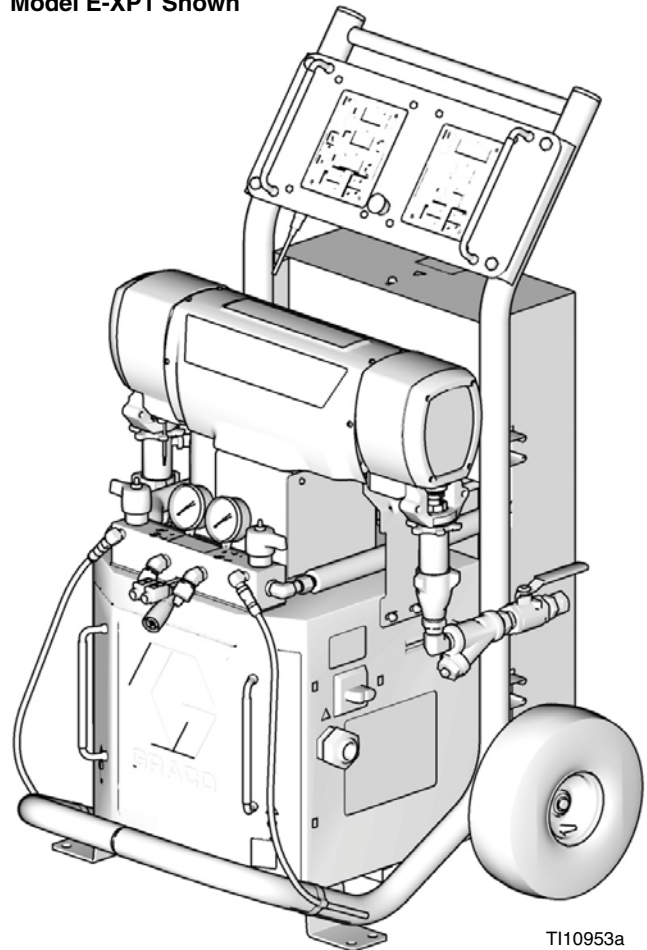

T110953a



Contents

Models	3	Repair	23
Supplied Manuals	4	Before Beginning Repair	23
Related Manuals	4	Pressure Relief Procedure	23
Warnings	5	Flushing	24
Temperature Control Diagnostic Codes	8	Pump Removal	24
E01: High fluid temperature	8	Pump Installation	26
E02: High zone current	9	Drive Housing	28
E03: No zone current	10	Motor Brushes	30
E04: Fluid Temperature Sensor (FTS) or thermocouple disconnected	10	Capacitor Test	32
E05: Circuit board overheated	10	Circuit Breaker Module	32
E06: Communication cable unplugged	10	Electric Motor	33
Motor Control Diagnostic Codes	11	Motor Control Board	34
Alarms	11	Transducers	36
Warnings	11	Electric Fan	36
E21: No component A transducer	12	Temperature Control Module	37
E22: No component B transducer	12	Primary Heaters	40
E23: High fluid pressure	12	Heated Hose	43
E24: Pressure Imbalance	12	Fluid Temperature Sensor (FTS)	44
E25: High line voltage	14	Display Module	46
E26: Low line voltage	14	Inlet Fluid Strainer Screen	48
E27: High Motor Temperature	14	Pump Lubrication System	48
E28: High current in motor	14	Parts	50
E29: Brush Wear	14	Reactor Assembly (Model E-XP1 Shown)	50
E31: Motor Control Failure (E-30 and E-XP2 only)	15	Parts Used on All Models	53
E32: Motor Control Overtemperature	16	Parts that Vary by Model	54
Communication Diagnostic Codes	16	Sub Assemblies	58
E30: Momentary loss of communication	16	Proportioner Module	58
E99: Loss of communication	16	10.2 kW and 6.0 kW Fluid Heaters	60
Troubleshooting	17	7.65 kW Single Zone Fluid Heater	61
Reactor Electronics	18	Reactor Frame	62
Primary Heaters (A and B)	20	Display	63
Hose Heat System	21	Temperature Control	64
		Motor Control	65
		Fluid Manifold	66
		Circuit Breaker Modules	67
		248669 Conversion Kit	71
		Dimensions	72
		Technical Data	73
		Graco Standard Warranty	74
		Graco Information	74

Models

E-20 SERIES

Part, Series	Full Load Peak Amps*	Voltage (phase)	System Watts†	Primary Heater Watts	Max Flow Rate◆ lb/min (kg/min)	Approximate Output per Cycle (A+B) gal. (liter)	Maximum Fluid Working Pressure psi (MPa, bar)
259025, E	48	230V (1)	10,200	6,000	20 (9)	0.0104 (0.04)	2000 (14, 140)
259030, E	24	400V (3)	10,200	6,000	20 (9)	0.0104 (0.04)	2000 (14, 140)
259034, E	32	230V (3)	10,200	6,000	20 (9)	0.0104 (0.04)	2000 (14, 140)

E-30 SERIES

Part, Series	Full Load Peak Amps*	Voltage (phase)	System Watts†	Primary Heater Watts	Max Flow Rate◆ lb/min (kg/min)	Approximate Output per Cycle (A+B) gal. (liter)	Maximum Fluid Working Pressure psi (MPa, bar)
259026, F	78	230V (1)	17,900	10,200	30 (13.5)	0.0272 (0.1034)	2000 (14, 140)
259031, F	34	400V (3)	17,900	10,200	30 (13.5)	0.0272 (0.1034)	2000 (14, 140)
259035, F	50	230V (3)	17,900	10,200	30 (13.5)	0.0272 (0.1034)	2000 (14, 140)
259057, F	100	230V (1)	23,000	15,300	30 (13.5)	0.0272 (0.1034)	2000 (14, 140)
259058, F	62	230V (3)	23,000	15,300	30 (13.5)	0.0272 (0.1034)	2000 (14, 140)
259059, F	35	400V (3)	23,000	15,300	30 (13.5)	0.0272 (0.1034)	2000 (14, 140)

E-XP1 SERIES

Part, Series	Full Load Peak Amps*	Voltage (phase)	System Watts†	Primary Heater Watts	Max Flow Rate◆ gpm (lpm)	Approximate Output per Cycle (A+B) gal. (liter)	Maximum Fluid Working Pressure psi (MPa, bar)
259024, E	69	230V (1)	15,800	10,200	1.0 (3.8)	0.0104 (0.04)	2500 (17.2, 172)
259029, E	24	400V (3)	15,800	10,200	1.0 (3.8)	0.0104 (0.04)	2500 (17.2, 172)
259033, E	43	230V (3)	15,800	10,200	1.0 (3.8)	0.0104 (0.04)	2500 (17.2, 172)

E-XP2 SERIES

Part, Series	Full Load Peak Amps*	Voltage (phase)	System Watts†	Primary Heater Watts	Max Flow Rate◆ gpm (lpm)	Approximate Output per Cycle (A+B) gal. (liter)	Maximum Fluid Working Pressure psi (MPa, bar)
259028, F	100	230V (1)	23,000	15,300	2.0 (7.6)	0.0203 (0.0771)	3200 (22, 220)
259032, F	35	400V (3)	23,000	15,300	2.0 (7.6)	0.0203 (0.0771)	3200 (22, 220)
259036, F	62	230V (3)	23,000	15,300	2.0 (7.6)	0.0203 (0.0771)	3200 (22, 220)

* Full load amps with all devices operating at maximum capabilities. Fuse requirements at various flow rates and mix chamber sizes may be less.

† Total system watts, based on maximum hose length for each unit:

- E-20 and E-XP1 series, 210 ft (64 m) maximum heated hose length, including whip hose.
- E-30 and E-XP2 series, 310 ft (94.5 m) maximum heated hose length, including whip hose.

◆ Maximum flow rate given for 60 Hz operation. For 50 Hz operation, maximum flow rate is 5/6 of 60 Hz maximum flow.

Supplied Manuals

The following manuals are shipped with the Reactor™ Proportioner. Refer to these manuals for detailed equipment information.

Order Part 15M334 for a compact disk of Reactor manuals translated in several languages.

Manuals are also available at www.graco.com.

Reactor Electric Proportioner	
Part	Description
312065	Reactor Electric Proportioner, Operation Manual (English)
Reactor Electrical Diagrams	
Part	Description
312067	Reactor Electric Proportioner, Electrical Diagrams (English)
Displacement Pump	
Part	Description
309577	Electric Reactor Displacement Pump Repair-Parts Manual (English)

Related Manuals





The following manuals are for accessories used with the Reactor™.





Order Part 15M334 for a compact disk of Reactor manuals translated in several languages.

Reactor Data Reporting Kit	
Part	Description
309867	Instruction-Parts Manual (English)
Fusion Spray Gun	
Part	Description
309550	Instruction-Parts Manual (English)
Heated Hose	
Part	Description
309572	Instruction-Parts Manual (English)
Circulation and Return Tube Kit	
Part	Description
309852	Instruction-Parts Manual (English)
Rupture Disk Assembly Kit	
Part	Description
312416	Instruction-Parts Manual (English)
Electric Reactor Installation	
Part	Description
310815	Instruction Manual (English)

Warnings

The following warnings are for the setup, use, grounding, maintenance, and repair of this equipment. The exclamation point symbol alerts you to a general warning and the hazard symbol refers to procedure-specific risk. Refer back to these warnings. Additional, product-specific warnings may be found throughout the body of this manual where applicable.

 WARNING	
	<p>ELECTRIC SHOCK HAZARD</p> <p>Improper grounding, setup, or usage of the system can cause electric shock.</p> <ul style="list-style-type: none"> • Turn off and disconnect power cord before servicing equipment. • Use only grounded electrical outlets. • Use only 3-wire extension cords. • Ensure ground prongs are intact on sprayer and extension cords. • Do not expose to rain. Store indoors.
	<p>TOXIC FLUID OR FUMES HAZARD</p> <p>Toxic fluids or fumes can cause serious injury or death if splashed in the eyes or on skin, inhaled, or swallowed.</p> <ul style="list-style-type: none"> • Read MSDS's to know the specific hazards of the fluids you are using. • Store hazardous fluid in approved containers, and dispose of it according to applicable guidelines. • Always wear impervious gloves when spraying or cleaning equipment.
	<p>PERSONAL PROTECTIVE EQUIPMENT</p> <p>You must wear appropriate protective equipment when operating, servicing, or when in the operating area of the equipment to help protect you from serious injury, including eye injury, inhalation of toxic fumes, burns, and hearing loss. This equipment includes but is not limited to:</p> <ul style="list-style-type: none"> • Protective eyewear • Clothing and respirator as recommended by the fluid and solvent manufacturer • Gloves • Hearing protection
	<p>SKIN INJECTION HAZARD</p> <p>High-pressure fluid from gun, hose leaks, or ruptured components will pierce skin. This may look like just a cut, but it is a serious injury that can result in amputation. Get immediate surgical treatment.</p> <ul style="list-style-type: none"> • Engage trigger lock when not spraying. • Do not point gun at anyone or at any part of the body. • Do not put your hand over the spray tip. • Do not stop or deflect leaks with your hand, body, glove, or rag. • Do not spray without tip guard and trigger guard installed. • Follow Pressure Relief Procedure in this manual, when you stop spraying and before cleaning, checking, or servicing equipment. • Tighten all fluid connections before operating equipment. • Check hoses and couplings daily. Replace worn or damaged parts immediately.

 WARNING	
	<p>FIRE AND EXPLOSION HAZARD</p> <p>Flammable fumes, such as solvent and paint fumes, in work area can ignite or explode. To help prevent fire and explosion:</p> <ul style="list-style-type: none"> • Use and clean equipment only in well ventilated area. • Eliminate all ignition sources; such as pilot lights, cigarettes, portable electric lamps, and plastic drop cloths (potential static arc). • Keep work area free of debris, including solvent, rags and gasoline. • Do not plug or unplug power cords or turn lights on or off when flammable fumes are present. • Ground equipment, personnel, object being sprayed, and conductive objects in work area. See Grounding instructions. • Use only Graco grounded hoses. • Check gun resistance daily. • If there is static sparking or you feel a shock, stop operation immediately. Do not use equipment until you identify and correct the problem. • Do not flush with gun electrostatics on. Do not turn on electrostatics until all solvent is removed from system. • Keep a working fire extinguisher in the work area.
	<p>THERMAL EXPANSION HAZARD</p> <p>Fluids subjected to heat in confined spaces, including hoses, can create a rapid rise in pressure due to the thermal expansion. Over-pressurization can result in equipment rupture and serious injury.</p> <ul style="list-style-type: none"> • Open a valve to relieve the fluid expansion during heating. • Replace hoses proactively at regular intervals based on your operating conditions.
	<p>PRESSURIZED ALUMINUM PARTS HAZARD</p> <p>Do not use 1,1,1-trichloroethane, methylene chloride, other halogenated hydrocarbon solvents or fluids containing such solvents in pressurized aluminum equipment. Such use can cause serious chemical reaction and equipment rupture, and result in death, serious injury, and property damage.</p>
	<p>EQUIPMENT MISUSE HAZARD</p> <p>Misuse can cause death or serious injury.</p> <ul style="list-style-type: none"> • This equipment is for professional use only. • Do not leave the work area while the equipment is energized or under pressure. Turn off all equipment and follow Pressure Relief Procedure in this manual when the equipment is not in use. • Do not operate the unit when fatigued or under the influence of drugs or alcohol. • Do not exceed the maximum working pressure or temperature rating of the lowest rated system component. See Technical Data in all equipment manuals. • Use fluids and solvents that are compatible with equipment wetted parts. See Technical Data in all equipment manuals. Read fluid and solvent manufacturer's warnings. For complete information about your material, request MSDS forms from distributor or retailer. • Check equipment daily. Repair or replace worn or damaged parts immediately with genuine manufacturer's replacement parts only. • Do not alter or modify equipment. • Use equipment only for its intended purpose. Call your distributor for information. • Route hoses and cables away from traffic areas, sharp edges, moving parts, and hot surfaces. • Do not kink or over bend hoses or use hoses to pull equipment. • Keep children and animals away from work area. • Comply with all applicable safety regulations.

 **WARNING****MOVING PARTS HAZARD**

Moving parts can pinch or amputate fingers and other body parts.

- Keep clear of moving parts.
- Do not operate equipment with protective guards or covers removed.
- Pressurized equipment can start without warning. Before checking, moving, or servicing equipment, follow the **Pressure Relief Procedure** in this manual. Disconnect power or air supply.

**BURN HAZARD**

Equipment surfaces and fluid that's heated can become very hot during operation. To avoid severe burns, do not touch hot fluid or equipment. Wait until equipment/fluid has cooled completely.

Temperature Control Diagnostic Codes

Temperature control diagnostic codes appear on temperature display.

These alarms turn off heat. E99 clears automatically when communication is regained. Codes E03 through

E06 can be cleared by pressing . For other codes,

turn main power OFF  then ON  to clear.

Code	Code Name	Alarm Zone	Corrective Action page
01	High fluid temperature	Individual	8
02	High zone current	Individual	9
03	No zone current with hose heater on	Individual	10
04	FTS not connected	Individual	10
05	Board overtemperature	Individual	10
06	Communication cable unplugged from module	Individual	10
99	Loss of communication	ALL	16



 For hose zone only, if FTS is disconnected at startup, display will show hose current 0A.

E01: High fluid temperature

Causes of E01 Errors

- Thermocouple A or B (310) senses a fluid temperature above 230°F (110°C).
- Fluid temperature sensor (FTS) senses a fluid temperature above 230°F (110°C).
- Overtemperature switch A or B (308) senses a fluid temperature above 230°F (110°C) and opens. At 190°F (87°C) the switch closes again.
- Thermocouple A or B (310) fails, is damaged, is not touching the heater element (307), or has a poor connection to the temperature control board.
- Overtemperature switch A or B (308) fails in the open position.
- The temperature control board fails to turn off any heat zone.
- Zone power wires or thermocouples are switched from one zone to another.
- Failed heater element where thermocouple is installed.
- Loose wire
- On 6.0 and 10.2 kW heater models only: Jumper wire on J1 connector, between module (3) and display (4), is loose or incorrectly wired.

Checks

				
<p>Troubleshooting this equipment requires access to parts that may cause electric shock or other serious injury if work is not performed properly. Have a qualified electrician perform all electrical troubleshooting. Be sure to shut off all power to the equipment before repairing.</p>				

Check which zone is displaying the E01 error.

1. Check that connector B is firmly plugged into temperature control board (see FIG. 5, page 37).
2. Clean and re-plug connections.
3. Check connections between the temperature control board and overtemperature switches A and B (308), and between temperature control board and thermocouples A and B (310) or FTS (21) [depending on which zone is displaying E01]. See Table 5, page 37. Ensure that all wires are securely connected to connector B.

4. Remove connector B from temperature control module, and check continuity of overtemperature switches A and B, thermocouples A and B, or FTS by measuring resistance across the pins on the plug end; see TABLE 1.

 Before doing the following checks, note which zone (A, B, FTS, or all) has high fluid temperature.

Table 1: Sensor Connector Continuity Checks

Pins	Description	Reading
1 & 2	OT switch A	nearly 0 ohms
3 & 4	OT switch B	nearly 0 ohms
5 & 6	Thermocouple A	4-6 ohms
8 & 9	Thermocouple B	4-6 ohms
11 & 12	FTS	approximately 35 ohms per 50 ft (15.2 m) of hose, plus approximately 10 ohms for FTS
10 & 12	FTS	open

5. Verify fluid temperature, using an external temperature sensing device.
 - **If temperature *is* too high (sensor reading is 229°F [109°C] or above):**
6. Check if thermocouples A and B are damaged, or not contacting the heater element, page 42.
7. To test that temperature control module turns off when equipment reaches temperature setpoint:
 - a. Set temperature setpoints far below displayed temperature.
 - b. Turn zone on. If temperature rises steadily, power board is failing.
 - c. Verify by swapping with another power module. See **Replacing Temperature Control Assembly Modules**, page 38.
 - d. If the swapped module does not fix the problem, the power module is not the cause.
8. Verify continuity of heater elements with an ohmmeter, see page 40.

E02: High zone current

1. Turn main power OFF

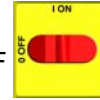

2. Relieve pressure, page 23.



Disconnect whip hose.

3. Disconnect hose connector (D) at Reactor.
4. Using an ohmmeter, check between the two terminals of the connector (D). There should be no continuity.
5. Exchange zone module with another one. Turn zone on and check for error. If error disappears, replace faulty module.

For hose zone: If error still occurs, perform **Transformer Primary Check** and **Transformer Secondary Check** starting on page 45.



When there is a a high current error, the LED on that zone's module will turn red while the error is displayed.

E03: No zone current

1. Check for tripped circuit breaker inside electrical cabinet or at power source for that zone. Replace circuit breaker if it trips habitually.
2. Check for loose or broken connection at that zone.
3. Exchange zone module with another one. Turn zone on and check for error (see page 38). If error disappears, replace faulty module.
4. If E03 occurs for all zones, the contactor may not be closing. Verify wiring from heater control to contactor coil.
 - a. *Hose zone*: test hose continuity, page 43.
 - b. Perform **Transformer Primary Check** and **Transformer Secondary Check**, starting on page 45.

 When a no current error occurs, the LED on the specific zone's module turns red when the error is displayed.

E04: Fluid Temperature Sensor (FTS) or thermocouple disconnected

1. Check temperature sensor connections to long green connector (B) on temperature control module, page 37. Unplug and re-plug sensor wires.
2. Test fluid temperature sensor continuity with ohmmeter, page 8.
3. If an error occurred for the hose zone, check FTS connections at each section of hose.
4. If an error occurred for the hose zone, test FTS by plugging directly into machine.

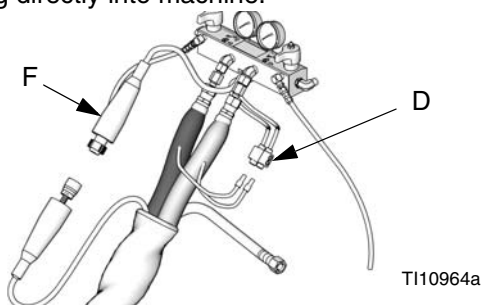

5. To verify heater control module is not causing the problem, use a wire to short-circuit the two pins corresponding to the FTS (red and yellow for A or B zone, red and purple for hose). The display will show the control heater module temperature.
6. If an error occurred for the hose zone, temporarily use the current control mode. Refer to Reactor Operation manual 312062.

E05: Circuit board overheated

 Each module has an on-board temperature sensor. Heat is turned off if module temperature exceeds 185°F (85°C) within the heater module.

1. Check that fan above electrical cabinet is operating.
2. Check that electrical cabinet door is properly installed.
3. Check for obstructions blocking cooling holes in bottom of electrical cabinet.
4. Clean heatsink fins behind heater control modules.
5. Ambient temperature may be too high. Allow Reactor to cool by moving to a cooler location.

E06: Communication cable unplugged

1. Unplug and re-plug cable that connects heater control module to heater module.
2. Replace communication cable if problem persists.

Motor Control Diagnostic Codes

Motor control diagnostic codes E21 through E29 appear on pressure display.

There are two types of motor control codes: alarms and warnings. Alarms take priority over warnings.

Alarms

Alarms turn off Reactor. Turn main power OFF

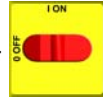

then ON



to clear.



Alarms can also be cleared, except for code 23, by

pressing .

Warnings

Reactor will continue to run. Press  to clear. A warning will not recur for a predetermined amount of time (varies for different warnings), or until main power

is turned OFF

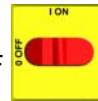

then ON



Code	Code Name	Alarm (A) or Warning (W)	Corrective Action page
21	No transducer (component A)	A	16
22	No transducer (component B)	A	16
23	High fluid pressure	A	16
24	Pressure imbalance	A/W (to select, see page 34)	16
25	High line voltage	A	18
26	Low line voltage	A	18
27	High motor temperature	A	18
28	High current	A	29
29	Brush wear	W	19
30	Momentary loss of communication	-	16
31	Motor control failure	A	15
32	Motor control overtemperature	A	16
99	Loss of communication	-	16

E21: No component A transducer

1. Check transducer A connection at J3 on motor control board, page 34, and clean contacts.
2. Reverse A and B transducer connections. If error moves to transducer B (E22), replace transducer A, page 36. If error does not move, replace motor control board, page 34.

E22: No component B transducer

1. Check transducer B connection at J8 on motor control board, page 35, and clean contacts.
2. Reverse A and B transducer connections. If error moves to transducer A (E21), replace transducer B, page 36. If error does not move, replace motor control board, page 34.

E23: High fluid pressure

1. Relieve pressure. Verify low pressure with analog

gauges. Turn main power OFF  then ON



. If error persists, do checks below.

1. Check the jumpers and the wiring. Check jumper on motor control board J10 for E20 and E-XP1, or J7 for E30 and E-XP2, pins 7-10, page 34.
2. Remove, clean and re-install the pressure transducer leads

If the jumpers and the wiring are in good working condition and you still have the error, then you will need to replace the “A” and “B” pressure transducers.

3. To determine if it’s the “A” or the “B” transducer, you will need a known good Reactor pressure transducer to use as a “test” transducer. The test is done without removing the existing pressure transducers from the fluid manifold.
 - a. Unplug the “A” transducer from the Motor control board socket (page 36) and replace with “test” transducer.

- b. Turn on the Reactor master power.
 - If the error is gone, turn off the Reactor main power, remove test transducer, and replace “A” transducer.
 - If the error persists, unplug the “test” transducer from the “A” socket, and reinstall the “A” pressure transducer back into the “A” socket. Repeat this test procedure on the “B” side.
4. If the error persists and no root cause is found through the above testing, replace the motor control board, page 34.

E24: Pressure Imbalance



If the pressure difference between components A and B exceeds 500 psi (3.5 MPa, 35 bar), an E24 will occur. This default value is adjustable; see the operation manual.



E24 can be an alarm or a warning, as desired. Set DIP switch on motor control board ON for alarm, OFF for warning. See page 34.

Fast E24 Errors

Fast E24 errors occur:

- within 10 seconds of turning the pumps on, or
- as soon as you trigger the gun.

Causes of Fast E24 Errors

- one side of the gun is plugged.
- a pressure transducer has failed.
- damaged pump seals or check valve.
- no feed pressure or empty material drum
- plugged heater.
- plugged hose.
- plugged manifold.
- one PRESSURE RELIEF/SPRAY valve is leaking or

is set to PRESSURE RELIEF/CIRCULATION 

Checks for Fast E24 Errors



If a fast E24 error occurs, first check the readings of the analog gauges.

If gauge pressures are very close

1. Clear the error and run the unit.
2. Check plug J10 (E20/E-XP1) or J7 (E30/E-XP2) or the jumpers 7 to 8, or 9 to 10 on the motor control board.
3. Check pressure transducer performance:

The digital display on a Reactor always shows the higher of the two pressures. As soon as the higher analog pressure drops below the lower analog pressure the digital display will switch to the new highest reading. Determine which transducer is performing poorly.

1. For testing purposes only, find the dip switches labeled SW2 on the motor control board, page 35. Set dips witch 3 to OFF. This will allow the Reactor to run with a pressure imbalance alarm.
2. Run the unit to build up some pressure (1000 – 1200 psi). Shut down the unit, clear the alarm and power back up. Do not depressurize the unit.
3. Check the analog gauges to see which pressure is higher. Check if the display pressure matches, indicating that the motor control board “sees” that transducer. If not, the motor control board does not “see” that transducer. Check the wire connections and or replace the transducer.
4. With the pump zone off, use the pressure relief valves to slowly relieve the “high” side pressure, while watching the digital display and the analog gauges. Once the higher analog gauge drops below the lower analog pressure the motor control board should start reading the “new” high side pressure (because it is now the higher of the two). Continue dropping the original “high” side pressure - the digital display should stop dropping. Repeat the process to check the other pressure transducer.

The last test determines if the pressure transducer has failed or if the socket on the pressure control board has gone bad.

1. Swap the transducer plug-ins on the motor control board. (J3 and J8 for the E-20 and E-XP1. J3 and J5 for the E30 and E-XP1).
2. Repeat above test.
3. If the problem stays with the same side as before, then the pressure transducer is bad.
4. If the problem switches to the other transducer, then the problem is in the motor control boards socket.

If the gauge readings are *not* equal.

1. Clear the error and balance the pressures using the dump valves.
2. If you cannot get the pressures to balance:
 - Check for pump failure.
 - Check for adequate material.
 - Using the feed pump to push fluid out through the gun manifold, check for a plugged fluid path.
 - Run the unit.
 - Check and clean the gun inlet screens.
 - Check and clean the mix chamber “A” and “B” impingement ports a well as the center port. **Note: Some mix chambers have counter bored holes, and require two drill sizes to clean impingement ports completely.**

“Slow” E24:

- When spraying, gradual pressure imbalance and eventual E24.

Possible Causes:

- One side of the Gun is partially blocked.
- The “A” or the “B” pump on the Reactor has failed.
- The “A” or the “B” feed pump has failed.
- The “A” or the “B” feed pump pressure is set too high.
- The “A” or the “B” inlet screen is plugged.
- The hose is not heating properly.
- Kinked supply hose.
- Bottom of the drum is damaged causing a blockage to the inlet of the feed pump.
- The drum is not vented properly.

E25: High line voltage

Supply voltage too high. Check Reactor voltage requirements, page 73.

E26: Low line voltage

Supply voltage too low. Check Reactor voltage requirements, page 73.

E27: High Motor Temperature

1. Motor temperature too high. Reduce pressure, gun tip size, or move Reactor to a cooler location. Allow one hour for cooling.
2. Check fan operation.
3. Ensure there is no obstruction around the fan area that would cause lack of airflow; ensure the motor/fan shroud is installed.
4. Ensure the unit is being operated with the front cover on.
5. Ensure the brush wear/over temp switch wire assembly is plugged into J7 (E-20/E-XP1) or J6 (E-30/E-XP2) of the motor control board.
6. With the main power off, unplug the wire harness from J7 (E-20/E-XP1) or J6 (E-30/E-XP2) on the motor control board and install a jumper wire on pins 1 and 2. Turn the main power back on.

If E27 is gone:

If the E27 error is gone and the motor is truly not overheated, then the problem can be in the motor/motor wire harness assembly. Measure the resistance between the two yellow wires that go to pins 1 and 2 of the motor connector. If there is an open connection, the thermal overload switch is open or there is a broken wire inside the motor, or a broken wire in the motor harness.

If the E27 error code is still there, double check if pins 1 and 2 are jumpered properly. If jumpered properly, then it would appear that the problem is with in the motor control board.

E28: High current in motor

Check motor control board:

1. Turn the master power off.
2. Disconnect socket J4 (E-20/E-XP1) J1 (E-30/E-XP2) on the motor control board.
3. Turn the master power back on.
4. If the E28 error did not go away then there is a problem with the motor control board. Replace board, page 34.

Check motor:

1. Check to see if the motor rotates freely.
2. Check to see if the brushes are damaged.
3. Check that the voltage going to the motor is good.
4. Check the three wire (yellow, yellow, orange) motor connector to the motor board. A gentle tug on each wire individually at the connector should identify the loose wire. If a wire pulls out, bend the locking tab on the crimp end, insert the wire until it seats and repeat gentle tug.
5. If the above does not resolve the problem, replace the motor, page 33.

E29: Brush Wear

CAUTION
Prolonged operation of motor after a brush wear warning may result in failure of motor and motor control board.

1. Check for normal brush wear, which causes the brush sensor to come in contact with the motor commutator. Replace the brushes, page 30.
2. Check spade plug. The spade plug inside the motor housing may be twisted and contacting the commutator side of the brush sensor assembly, causing a false alarm. Follow the orange wire coming from J7 (E-20/E-XP1), or J6 (E-30/E-XP2), up to the spade connector on the motor. Using a flashlight, ensure the spade plug assembly is **not** making contact with the metal housing of the brush assembly.

3. Check wiring. The orange brush sensor wire coming out of the brush may be routed online with the commutator wiring (thick red wire), causing a false alarm. Reroute the orange wire coming out of the brush, away from the commutator wiring.
4. Check motor control board.
 - Remove the plug in J7 (E-20/E-XP1), or J6 (E-30/E-XP2). (This will cause an E27 alarm).
 - To remove the E27 alarm, use a jumper wire on the motor control board, across the two pins that the two yellow wires plug into. Then turn the unit on.
 - The E27 as well as the E29 alarm should be gone. If the E27 alarm is not gone double-check your jumper.
 - If the jumper is installed correctly and the E29 alarm is still there, replace the motor control board, page 34.



E31: Motor Control Failure (E-30 and E-XP2 only)

The E31 error code represents a motor drive error. This indicates that the 24G881 motor control board has malfunctioned and needs to be replaced. A motor control board failure may also be indicated by the motor starting up immediately upon the application of power to the system, without pressing . This is an indication that the output drivers of the motor control have shorted out and are delivering full power to the motor at all times.

The cause of the failure may be one of the following conditions: motor failure, capacitor failure, shorted or frayed wiring, or inadequate power supply. Perform the following procedure before replacing the motor control board.

The cause of the failure may be one of the following conditions: motor failure, capacitor failure, shorted or frayed wiring, or inadequate power supply. Perform the following procedure before replacing the motor control board.

1. Turn main power OFF . Disconnect power supply.

				
Wait 5 minutes for stored voltage to discharge (E-30 and E-XP2 models only).				

2. Relieve pressure, page 23.
3. Perform the following inspections.
 - a. **Motor failure:** Inspect the motor commutator by removing the top brush (see Brush Removal, page 30). Rotate the motor, inspecting the whole commutator for burns, pocking, or shorts between poles. Continue rotating the motor for a complete pump cycle, up and down, to ensure that there is no mechanical interference or restriction in the pump lower or gear drive system.
 - b. **Capacitor failure:** Inspect and test the motor start capacitor, following the Capacitor Test instructions on page 32.
 - c. **Shorted or frayed wiring:** Inspect all wiring connected to the motor control board and the motor, for shorts or frayed insulation. Replace any compromised wires with wire of the same gauge, color, and temperature rating.
 - d. **Inadequate power supply:** Verify that the power source is of the correct voltage and current rating for the system, and that all phases are properly connected. Ensure that the power does not dip or surge during operation.

Prior to shutting down the generator, ensure that the motor has stopped and the main disconnect is opened. If the generator is stopped during operation, even due to running out of fuel, the drop in supply voltage may cause a motor drive failure.

E32: Motor Control Overtemperature

The E32 error code indicates a high temperature condition within the motor control board (701). This could be caused by an abnormally high ambient temperature in the work location, blockage of cooling vents in the cabinet, or the failure of the cooling fan inside the cabinet.

1. Relieve pressure, page 23. Verify low pressure with analog gauges.

2. Turn main power OFF  then ON .

If error still remains, identify cause of the overtemperature condition and remedy.

Communication Diagnostic Codes

E30: Momentary loss of communication



Communications between the display and the motor control board or the temperature control board have been momentarily lost. Normally, when communication is lost, the corresponding display will show E99. The corresponding control board will register E30 (The red LED will flash 30 times). If communications are reconnected, the display can show the E30 for a short time (no more than about two seconds). It should not be possible for E30 to be shown continuously, unless there is a loose connection causing the display and the board to continuously lose and regain communication.

Check all wiring between the display and the corresponding control board.

E99: Loss of communication

Communications between the display and the motor control board or the temperature control board has been lost. When communication is lost, the corresponding display will show E99.

1. Check all wiring between the display and the corresponding control board. Pay close attention to the wire crimping on plug J13 for each board.

				
Step 2 measures line voltage and should be done by a qualified electrician. If work is not performed properly it may cause electric shock or other serious injury.				

2. Measure the incoming voltage to the board (it should be ~ 230Vac).
3. If it was only receiving 1 leg of the 230Vac the board may light up, and still not function properly. Correct the incoming voltage problem.

Troubleshooting

PROBLEM	CAUSE	SOLUTION
Reactor does not operate.	No power.	Plug in power cord.
		Turn main power ON 
		Turn circuit breakers ON, page 32.
	Red stop button circuit open.	Check button connections. See page 46 and electrical diagrams.
Motor does not operate.	Loose connections.	Check connections at motor control board.
	Circuit breaker tripped.	Reset breaker (CB5), page 32. Check 230Vac at output of breaker.
	Worn brushes.	Check both sides. Length must be 0.7 in. (17 mm) minimum. To replace, page 30.
	Broken or misaligned brush springs.	Realign or replace, page 30.
	Brushes or springs binding in brush holder.	Clean brush holder and align brush leads for free movement.
	Shorted armature.	Replace motor, page 33.
	Check motor commutator for burn spots or other damage.	Remove motor. Have motor shop resurface commutator, if possible.
	Damaged motor control board.	Replace board. See page 34.
Fan not working.	Blown fuse.	Replace, page 36.
	Loose wire.	Check.
	Defective fan.	Replace, page 36.
Pump output low.	Obstructed fluid hose or gun; fluid hose ID too small.	Open, clear; use hose with larger ID.
	Worn piston valve or intake valve in displacement pump.	See pump manual.
	Pressure setpoint too high.	Reduce setpoint and output will increase.
Fluid leak in pump packing nut area.	Worn throat seals.	Replace. See pump manual.
No pressure on one side.	Fluid leaking from heater inlet rupture disk (314).	Check if heater (2) and PRESSURE RELIEF/SPRAY valve (SA or SB) are plugged. Clear. Replace rupture disk (314) with a new one; do not replace with a pipe plug.

Reactor Electronics



Before performing any troubleshooting procedures:

1. Relieve pressure, page 23.

2. Turn main power OFF



3. Allow equipment to cool.

Try the recommended solutions in the order given for each problem, to avoid unnecessary repairs. Also, determine that all circuit breakers, switches, and controls are properly set and wiring is correct before assuming there is a problem.

PROBLEM	CAUSE	SOLUTION
Both sides of display do not illuminate.	No power.	Plug in power cord. Turn disconnect ON 
	Low voltage.	Ensure input voltage is within specifications, page 46.
	Loose wire.	Check connections, page 46.
	Display disconnected.	Check cable connections, page 46.
Temperature display does not illuminate.	Display disconnected.	Check cable connections, page 46.
	Display cable damaged or corroded.	Clean connections; replace cable if is damaged.
	Defective circuit board.	Swap display connection to motor control board with connection to heater control board. If temperature display illuminates, heater control board is causing problem. Otherwise, display cable or display is failing.
Pressure display does not illuminate.	Display disconnected.	Check cable connections, page 46.
	Display cable damaged or corroded.	Clean connections; replace cable if is damaged.
	Defective circuit board.	Swap display connection to motor control board with connection to heater control board. If pressure display illuminates, motor control board is causing problem. Otherwise, display cable or display is failing.
Erratic display; display turns on and off.	Low voltage.	Ensure input voltage is within specifications, page 46.
	Poor display connection.	Check cable connections, page 46. Replace damaged cable.
	Display cable damaged or corroded.	Clean connections; replace cable if is damaged.
	Display cable not grounded.	Ground cable, page 46.
	Display extension cable too long.	Must not exceed 100 ft (30.5 m)
Hose display reads OA at startup.	FTS disconnected or not installed.	Verify proper installation of FTS (see Operation manual 312065), or adjust FTS to desired current setting.

PROBLEM	CAUSE	SOLUTION
Display does not respond properly to button pushes.	Poor display connection.	Check cable connections, page 46. Replace damaged cable.
	Display cable damaged or corroded.	Clean connections; replace cable if is damaged.
	Ribbon cable on display circuit board disconnected or broken.	Connect cable (page 46) or replace.
	Broken display button.	Replace, page 46.
Red stop button does not work.	Broken button (fused contact).	Replace, page 46.
	Loose wire.	Check connections, page 46.
Fan not working.	Blown fuse.	Verify with ohmmeter; replace if necessary (page 46).
	Loose wire.	Check fan wire.
	Defective fan.	Replace, page 46.

Primary Heaters (A and B)



Before performing any troubleshooting procedures:

1. Relieve pressure, page 23.

2. Turn main power OFF



3. Allow equipment to cool.

Try the recommended solutions in the order given for each problem, to avoid unnecessary repairs. Also, determine that all circuit breakers, switches, and controls are properly set and wiring is correct before assuming there is a problem.

PROBLEM	CAUSE	SOLUTION
Primary heater(s) does not heat.	Heat turned off.	Press A or B zone I keys.
	Temperature control alarm.	Check temperature display for diagnostic code, page 8.
	Signal failure from thermocouple.	See E04: Fluid Temperature Sensor (FTS) or thermocouple disconnected , page 10.
Control of primary heat is abnormal; high temperature overshoots or E01 error occurs intermittently.	Dirty thermocouple connections.	Examine connection of thermocouples to long green plug on heater control board. Unplug and re-plug thermocouple wires, cleaning off any debris. Unplug and re-plug long green connector.
	Thermocouple not contacting heater element.	Loosen ferrule nut (N), push in thermocouple (310) so tip (T) contacts heater element (307). Holding thermocouple tip (T) against heater element, tighten ferrule nut (N) 1/4 turn past tight. See page 42 for illustration.
	Failed heater element.	See Primary Heaters, page 20.
	Signal failure from thermocouple.	See E04: Fluid Temperature Sensor (FTS) or thermocouple disconnected , page 10.
	Thermocouple wired incorrectly.	See E04: Fluid Temperature Sensor (FTS) or thermocouple disconnected , page 10. Power up zones one at a time and verify that temperature for each zone rises.

Hose Heat System



Before performing any troubleshooting procedures:

1. Relieve pressure, page 23.

2. Turn main power OFF





3. Allow equipment to cool.



Problems

Try the recommended solutions in the order given for each problem, to avoid unnecessary repairs. Also, determine that all circuit breakers, switches, and controls are properly set and wiring is correct before assuming there is a problem.

PROBLEM	CAUSE	SOLUTION
Hose heats but heats slower than usual or it does not reach temperature.	Ambient temperature is too cold.	Use auxiliary hose heat system.
	FTS failed or not installed correctly.	Check FTS, page 10.
	Low supply voltage.	Verify line voltage. Low line voltage significantly reduces power available to hose heat system, affecting longer hose lengths.
Hose does not maintain temperature while spraying.	A and B setpoints too low.	Increase A and B setpoints. Hose is designed to maintain temperature, not to increase it.
	Ambient temperature is too cold.	Increase A and B setpoints to increase fluid temperature and keep it steady.
	Flow too high.	Use smaller mix chamber. Decrease pressure.
	Hose was not fully preheated.	Wait for hose to heat to correct temperature before spraying.
	Low supply voltage.	Verify line voltage. Low line voltage significantly reduces power available to hose heat system, affecting longer hose lengths.
Hose temperature exceeds setpoint.	A and/or B heaters are overheating material.	Check primary heaters for either a thermocouple problem or a failed element attached to thermocouple, page 10.
	Faulty thermocouple connections.	Verify that all FTS connections are snug and that pins of connectors are clean. Examine connection of thermocouples to long green plug on heater control board. Unplug and re-plug thermocouple wires, cleaning off any debris. Unplug and re-plug long green connector on heater control board.

PROBLEM	CAUSE	SOLUTION
Erratic hose temperature.	Faulty thermocouple connections.	Verify that all FTS connections are snug and that pins of connectors are clean. Examine connection of thermocouples to long green plug on heater control board. Unplug and re-plug thermocouple wires, cleaning off any debris. Unplug and re-plug long green connector.
	FTS not installed correctly.	FTS should be installed close to end of hose in same environment as gun. Verify FTS installation, page 44.
Hose does not heat.	FTS failed or is not contacting correctly.	Check FTS, page 44.
	FTS not installed correctly.	FTS should be installed close to end of hose in same environment as gun. Verify FTS installation, page 44.
	Temperature control alarm.	Check temperature display or diagnostic code, page 44.
Hoses near Reactor are warm, but hoses downstream are cold.	Shorted connection or failed hose heating element.	With hose heat on and temperature setpoint above displayed hose zone temperature, verify voltage between connectors at each section of hose. Voltage should drop incrementally for each section of hose further from Reactor. Use safety precautions when hose heat is turned on.
No hose heat. Low hose heat.	Loose hose electrical connections.	Check connections. Repair as necessary.
	Circuit breakers tripped.	Reset breakers (CB1 or CB2), page 32.
	Hose zone not turned on.	Press  zone  key.
	A and B temperature setpoints too low.	Check. Increase if necessary.
	Failed temperature control board.	Open cabinet. Check if board LED is blinking. If not, check power wiring connections to ensure board has power. If board has power and LED is not blinking, replace board, page 37.
	A and B temperature setpoints too low.	Increase A and B setpoints. Hose designed to maintain temperature, not increase temperature.
	Hose temperature setpoint too low.	Check. Increase if necessary to maintain heat.
	Flow too high.	Use smaller mix chamber. Decrease pressure.
	Low current; FTS not installed.	Install FTS, see operation manual.
	Hose heat zone not turned on long enough.	Allow hose to heat up, or preheat fluid.
Loose hose electrical connections.	Check connections. Repair as necessary.	

Repair

				
<p>Repairing this equipment requires access to parts that may cause electric shock or other serious injury if work is not performed properly. Have a qualified electrician connect power and ground to main power switch terminals, see operation manual. Be sure to shut off all power to the equipment before repairing.</p>				

Before Beginning Repair

1. Flush if necessary; see **Flushing**.
2. Park component A pump.



- b. Trigger gun until pump A stops. After fluid pressure drops below 700 psi (7.9 MPa, 79 bar), motor will run until component A pump is at bottom of its stroke, then shut off.

- c. Check ISO reservoir for component A pump. Fill wet cup on component B pump. Refer to Reactor Operation manual 312065.

3. Turn main power OFF 

4. Relieve pressure.

Pressure Relief Procedure

				
---	---	--	--	--

1. Relieve pressure in gun and perform gun shutdown procedure. See gun manual.

2. Engage gun piston safety lock.



ti2409a

3. Close gun fluid manifold valves A and B.

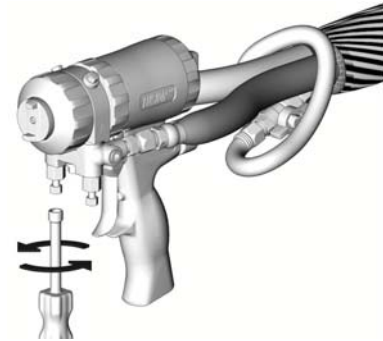

ti2421a

4. Shut off feed pumps and agitator, if used.

5. Turn PRESSURE RELIEF/SPRAY valves (SA, SB)

to PRESSURE RELIEF/CIRCULATION . Route fluid to waste containers or supply tanks. Ensure gauges drop to 0.

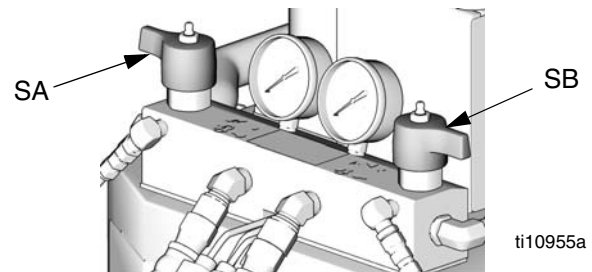

ti10955a

6. Disconnect gun air line and remove gun fluid manifold.

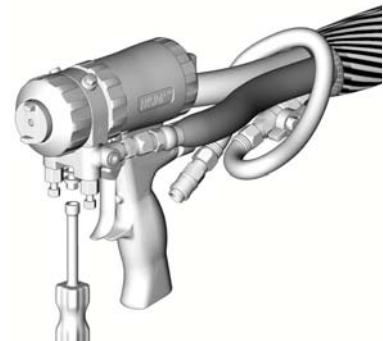

ti2554a

Flushing

<p>Flush equipment only in a well-ventilated area. Do not spray flammable fluids. Do not turn on heaters while flushing with flammable solvents.</p>				

- Flush out old fluid with new fluid, or flush out old fluid with a compatible solvent before introducing new fluid.
- Use the lowest possible pressure when flushing.
- All fluid components are compatible with common solvents. Use only moisture-free solvents.
- To flush feed hoses, pumps, and heaters separately from heated hoses, set PRESSURE RELIEF/SPRAY valves (SA, SB) to PRESSURE

RELIEF/CIRCULATION . Flush through bleed lines (N).

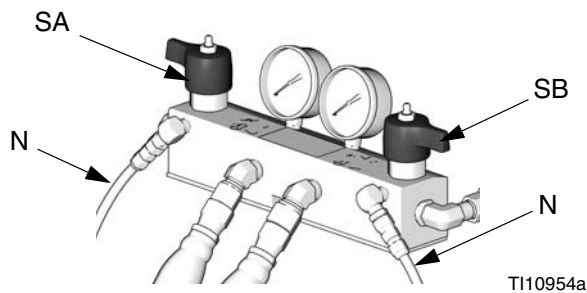

- To flush entire system, circulate through gun fluid manifold (with manifold removed from gun).
- To prevent moisture from reacting with isocyanate, always leave the system dry or filled with a moisture-free plasticizer or oil. Do not use water.

Pump Removal

<p>Pump rod and connecting rod move during operation. Moving parts can cause serious injury such as pinching or amputation. Keep hands and fingers away from connecting rod during operation.</p>				

See manual 309577 for pump repair instructions.

1. Shut off **A** , **B** , and heat zones.
2. Flush pump.
3. If pumps are not parked, press . Trigger gun until pumps stop.
4. Turn main power off . Disconnect power supply.
5. Shut off both feed pumps. Close both fluid inlet ball valves (B).

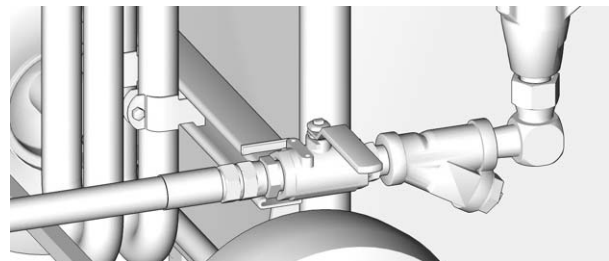

ti4147a

6. Turn both PRESSURE RELIEF/SPRAY valves (SA, SB) to PRESSURE RELIEF. Route fluid to waste containers or supply tanks. Ensure gauges drop to 0.

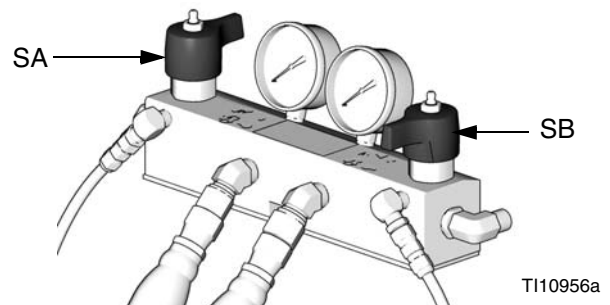

 Use drop cloth or rags to protect Reactor and surrounding areas from spills.

 Steps 7-9 apply to pump A. To disconnect pump B, go to steps 10 and 11.

7. Disconnect fittings at fluid inlet (C) and outlet (D, out of view). Also disconnect steel outlet tube from heater inlet.
8. Disconnect tubes (T). Remove tube fittings (U) from wet-cup.
9. Loosen locknut (G) by hitting firmly with a non-sparking hammer. Unscrew pump far enough to separate and push up finger guard (P), to expose rod retaining pin. Push retaining wire clip up. Push pin out. Continue unscrewing pump.

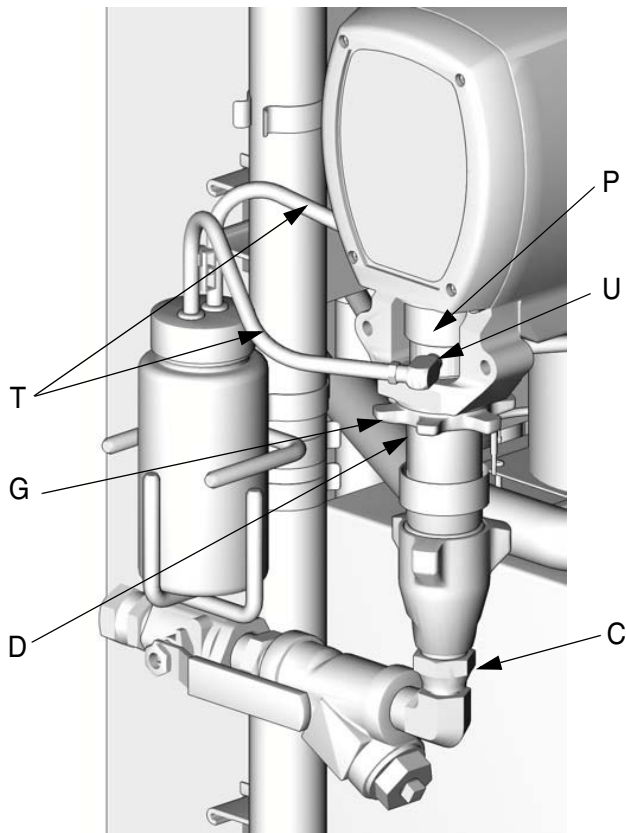

 Steps 10 and 11 apply to pump B.

10. Disconnect fluid inlet (C) and outlet (D). Also disconnect steel outlet tube from heater inlet.
11. Push retaining wire clip (E) up. Push pin (F) out. Loosen locknut (G) by hitting firmly with a non-sparking hammer. Unscrew pump.

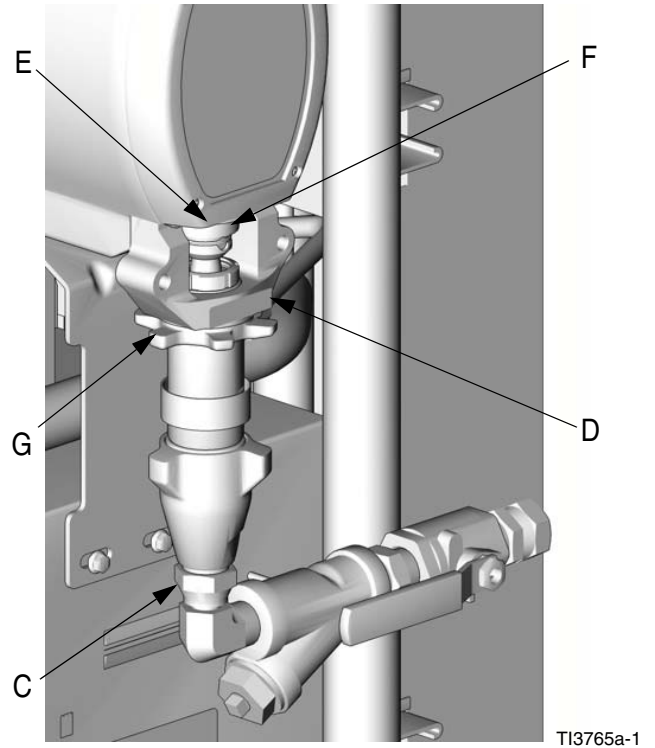

Pump Installation

 Steps 1-5 supply to pump B. To reconnect pump A, proceed to step 6.

1. Ensure locknut (G) is screwed on pump with flat side up. Screw pump into bearing housing (M) until pin holes align. Push pin (F) in. Pull retaining wire clip (E) down.

2. Continue screwing pump into housing until fluid outlet (D) is aligned with steel tube and top threads are +/- 1/16 in. (2 mm) of bearing face (N).
3. Tighten locknut (G) by hitting firmly with a non-sparking hammer.
4. Reconnect fluid inlet (C) and outlet (D).
5. Go to step 13.

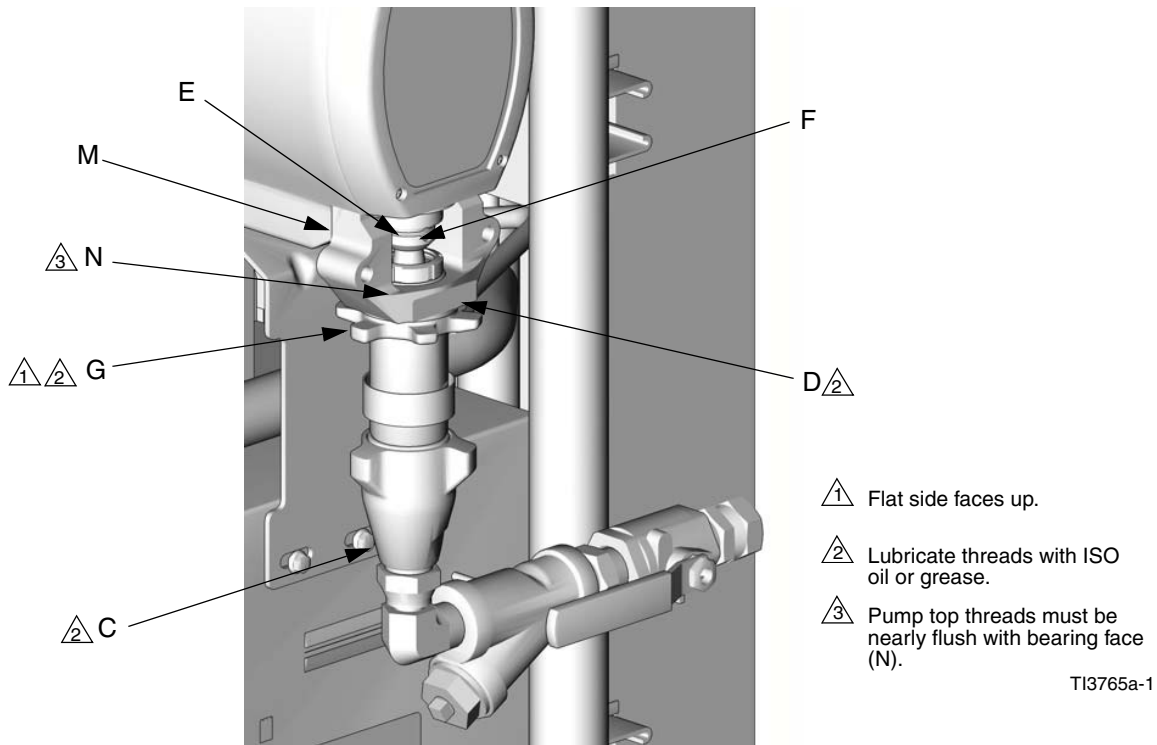



Steps 6-12 apply to pump A only.

6. Ensure star-shaped locknut (G) is screwed on pump with flat side up. Carefully twist and extend displacement rod 2 in. (51 mm) above wet-cup.
7. Start threading pump into bearing housing (M). Place finger guard (P) over rod when it is accessible through window of bearing housing. When pin holes align, insert pin. Pull retaining wire clip down.



Finger guard is not used on Model E-30.

8. Seat finger guard (P) on wet-cup. Continue threading pump into bearing housing (M) until top threads are +/- 1/16 in. (2 mm) of bearing face (N). Ensure

that barbed fittings at wet-cup flush ports are accessible.

9. Connect component A outlet tube loosely at pump and at heater. Line up tube, then tighten fittings securely.
10. Tighten star-shaped locknut (G) by hitting firmly with a non-sparking hammer.
11. Apply thin film of TSL to barbed fittings. Using two hands, support tubes (T) while pushing straight onto barbed fittings. **Do not let tubes kink or buckle.** Secure each tube with a wire tie between two bars.
12. Reconnect fluid inlet (C).
13. Purge air and prime the system. See Reactor operation manual.

① Flat side faces up.

② Lubricate threads with ISO oil or grease.

③ Pump top threads must be nearly flush with bearing face (N).

④ Finger guard (P) not used on Model E-30.

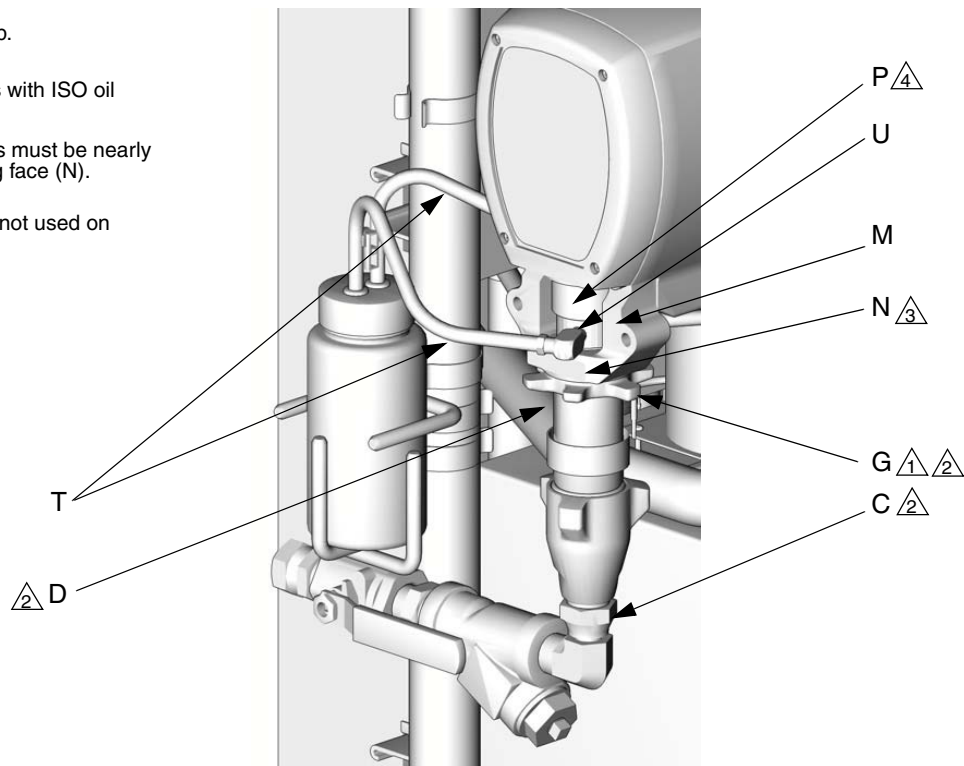

TI3765a-2

Drive Housing

Removal

1. Turn main power OFF . Disconnect power supply.
2. Relieve pressure, page 23.
3. Remove screws (38) and motor shield (9), page 50.

4. Remove screws (209) and front cover (217).

 Examine bearing housing (203) and connecting rod (205). If these parts need replacing, first remove the pump (206), page 28.

5. Disconnect pump inlet and outlet lines. Remove screws (213), washers (215), and bearing housing (203).

CAUTION
Do not drop gear cluster (204) when removing drive housing (202). Gear cluster may stay engaged in motor front end bell (R) or drive housing.

6. Remove screws (212, 219) and washers (214) and pull drive housing (202) off motor (201).

 The A side drive housing includes cycle counter switch (221). If replacing this housing, remove pins (P) and switch. Reinstall pins and switch on new drive housing. Switch wires connect to J10 pins 5 and 6 on motor control board, page 34.

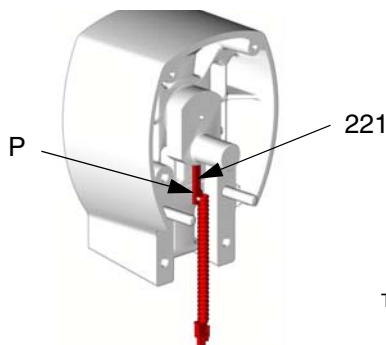

Installation

1. Apply grease liberally to washers (207, 208, 218), all gears, and inside drive housing (202).
2. Install one bronze washer (208) in drive housing, then install steel washers (207, 218) as shown.
3. Install second bronze washer (208) on gear cluster (204) and insert gear cluster in drive housing.

 Drive housing crankshaft (S) must be in line with crankshaft at other end of motor.

4. Push drive housing (202) onto motor (201). Install screws (212, 219) and washers (214).

 If bearing housing (203), connecting rod (205), or pump (206) were removed, reassemble rod in housing and install pump, page 26.

5. Install bearing housing (203), screws (213), and washers (215). Pumps must be in phase (both at same position in stroke).
6. Install front cover (217) and screws (209).
7. Install motor shield (9) and screws (38).

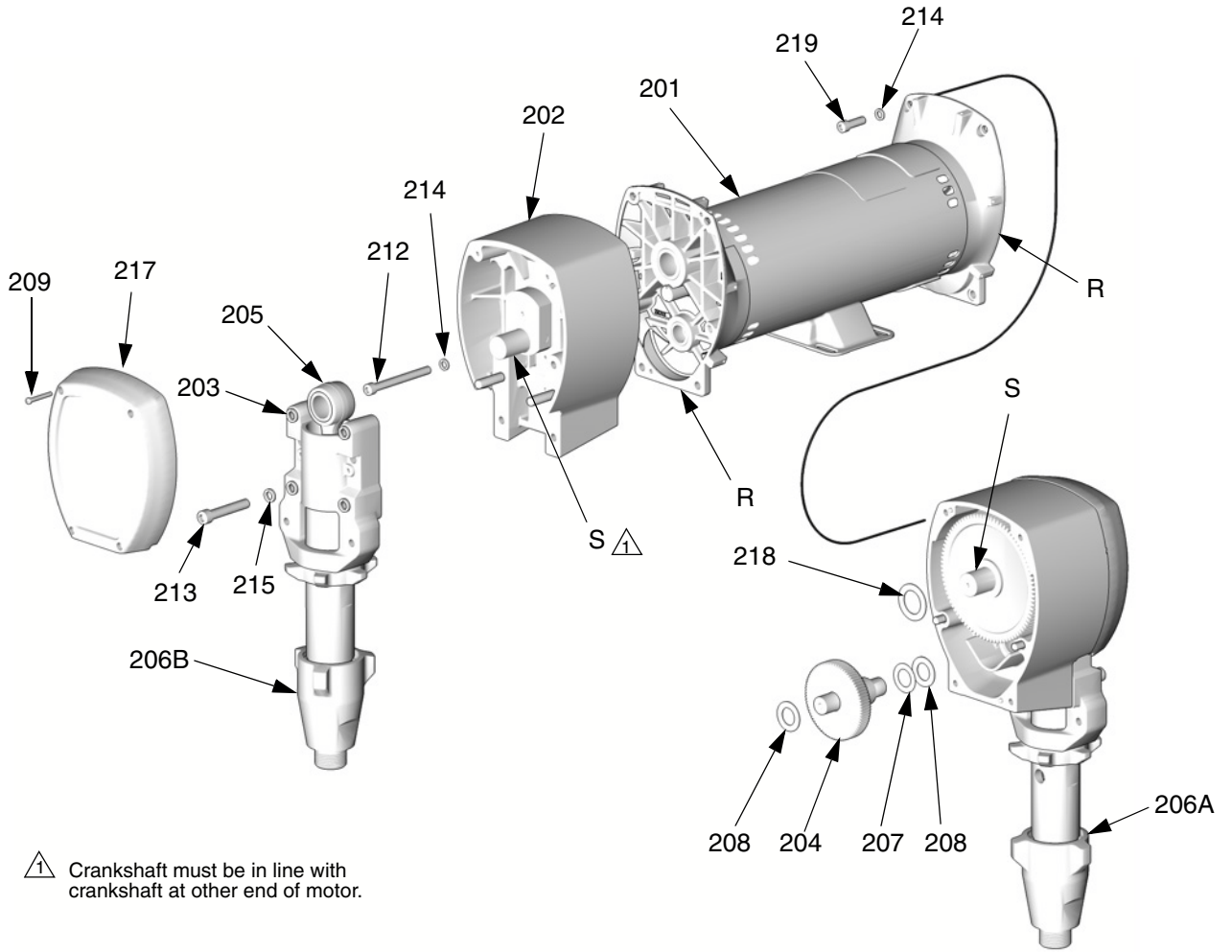



TI3152

Motor Brushes

Brush Removal

 Replace brushes worn to less than 1/2 in. (13 mm). Brushes wear differently on each side of motor; check both sides. Brush Repair Kit 234037 is available.

1. Turn main power OFF . Disconnect power supply.

				
Wait 5 min for stored voltage to discharge (E-30 and E-XP2 models only).				

2. Relieve pressure, page 23.
3. Remove motor cover, screw, and washers. Remove inspection covers, screws, and gaskets from each end of motor.
4. Push in spring clip (C) to release hooks (H) from brush holder. Pull out clip and spring (S).

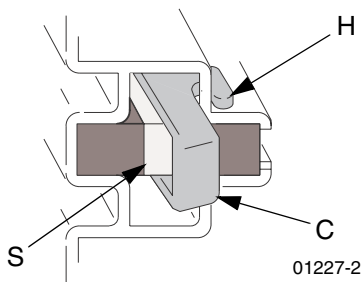

 One brush has a wire on top for brush wear signal. Note which side of motor it is on. Unplug at spade connector provided.

5. Loosen terminal screw (R). Pull away brush lead (L), being careful motor lead terminal (T) remains in place. Remove and discard brush (B).

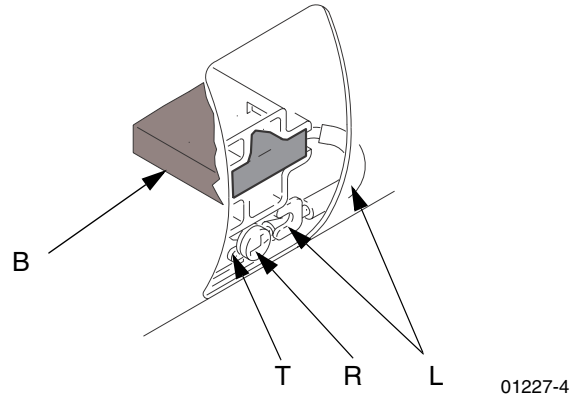

6. Inspect commutator for excessive pitting, burning, or gouging. Black color on commutator is normal. Have commutator resurfaced by qualified motor repair shop if brushes wear too quickly.
7. Repeat for other side.

Brush Installation

CAUTION

When installing brushes, follow steps carefully. Improper installation damages parts beyond use.

 Install brush with wires on same side of motor as before. Plug spade terminal into connector.

1. Install new brush (B) so lead (L) is in long slot (D) of holder.

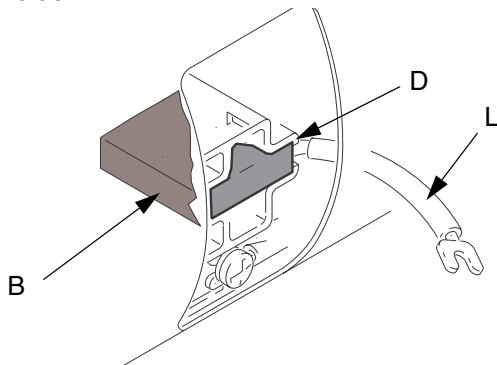

01227-5

2. Slide terminal (L) under terminal screw (R). Make sure motor lead terminal (T) is still connected at screw. Tighten screw.

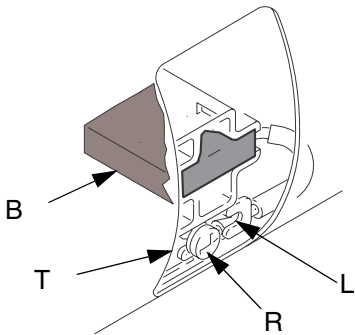

01227-4

3. Install spring (S) so it will uncoil onto brush (B), as shown. Spring will be damaged if installed backwards.

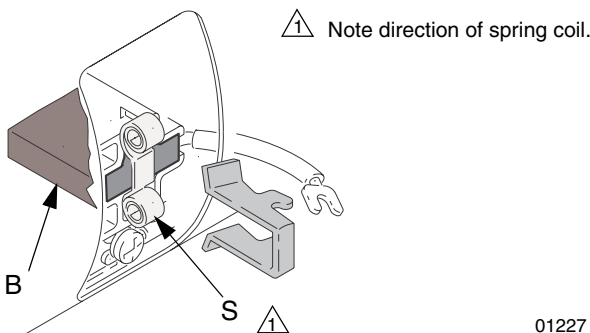

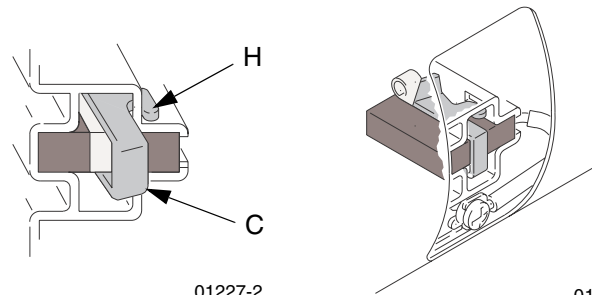

01227

4. Install spring clip (C) and push in until hooks (H) catch slots in housing. Incorrect installation may jam clip.



01227-2

01227-6

					
Do not touch brushes, leads, springs, or brush holders while equipment is plugged in, to reduce the risk of electric shock and serious injury.					

CAUTION

Do not run pumps dry for more than 30 sec while checking brushes, to avoid damaging pumps.

5. Reinstall brush inspection covers, gaskets, and screws. Reinstall motor cover, screws, washers, and drive housing/pump assemblies.
6. Test brushes with both pump pins (F) disconnected, page 30.

Select J 1 (jog mode). Press motor  to start motor. Slowly increase jog setting to J 6. Inspect brush and commutator contact area for excessive arcing. Arcs should not "trail" or circle around commutator surface.

Run motor for 20-30 min at J 6 to seat brushes.

Capacitor Test

1. Turn main power OFF . Disconnect power supply.
2. Relieve pressure, page 23.
3. Locate the large, blue capacitor in the upper right corner of the lower cabinet.
4. With a DC voltmeter, measure the voltage across the capacitor terminals to verify that the voltage has discharged to below 10 volts.
5. With an insulated handle screw driver, short across the two contacts on the end of the capacitor to complete discharging it. Hold for two seconds.

NOTE: A small spark may issue from the contact point.

6. Inspect the capacitor for irregularities such as cracks, leakage, burn marks, or irregular shape.
7. Set an Ohmmeter to a range of at least $1K\Omega$ and connect the meter leads to the capacitor with the red lead to the positive (+) terminal and the black lead to the negative (-) terminal.
8. Observe the meter reading. It should start near 0Ω and climb up to $10K\Omega$, $20K\Omega$, etc., as the meter battery charges the capacitor. This indicates a good capacitor.
9. A reading of 0Ω (shorted) or O.L (open) indicates a bad capacitor. In this case, replace the capacitor with the exact replacement part, item 76 on pages 55 and 56.

Circuit Breaker Module

1. Turn main power OFF . Disconnect power supply. Turn circuit breakers on to test.

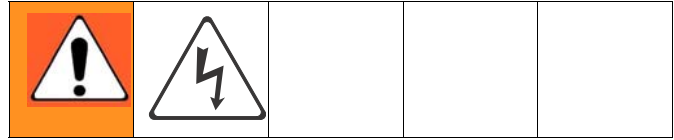

2. Relieve pressure, page 23.
3. Using an ohmmeter, check for continuity across circuit breaker (top to bottom). If no continuity, trip breaker, reset, and retest. If still no continuity, replace breaker as follows:
 - a. Refer to electrical diagrams and to TABLE 2. Disconnect wires and remove bad breaker.
 - b. Install new breaker and reconnect wires.

Table 2: Circuit Breakers, see FIG. 1

Ref.	Size	Component
909	50A	Hose/Transformer Secondary Side
911	40A	Transformer Primary
912A	25A, 40A*	Heater A
912B	25A, 40A*	Heater B
913	20A	Motor/Pumps

* Depending on model.

NOTE: To reference cables and connectors, see the electrical diagrams and the parts drawings on pages 67-68.

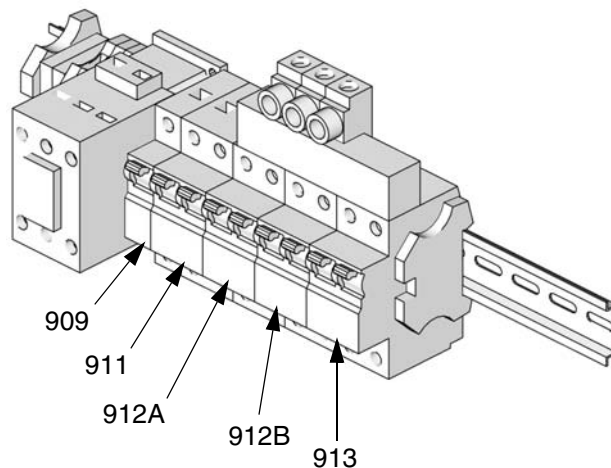

ti9884a

FIG. 1. Circuit Breaker Module

Electric Motor

Removal

1. Turn main power OFF . Disconnect power supply.

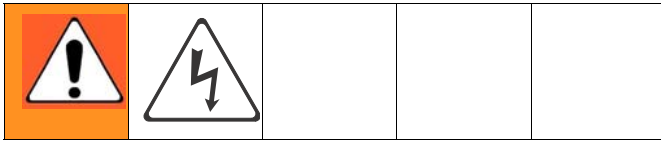

2. Relieve pressure, page 23.
3. Remove drive housing/pump assemblies, page 28.
4. Disconnect motor cables as follows:
 - a. Refer to electrical diagrams. Motor control board is on right side inside cabinet, see page 34.
 - b. Unplug motor power harness from connector J4 on board. See FIG. 2, page 35.
 - c. Unplug 3-pin connector J7 from board.
 - d. Thread cables through top of cabinet to free motor.

CAUTION

Motor is heavy. Two people may be required to lift.

5. Remove screws holding motor to bracket. Lift motor off unit.

Installation

1. Place motor on unit. Thread motor cables into cabinet and into bundles as before. See electrical diagrams.
2. Fasten motor with screws.
3. Plug 3-pin connector J7 to board.
4. Plug motor power harness to connector J4 on board.
5. Install drive housing/pump assemblies, page 28.
6. Return to service.

Motor Control Board



 Motor control board has one red LED (D11). Power must be on to check. See FIG. 2 for location. Function is:

- Startup: 1 blink for 60 Hz, 2 blinks for 50 Hz.
- Motor running: LED on.
- Motor not running: LED off.
- Diagnostic code (motor not running): LED blinks diagnostic code, pauses, then repeats (for example, E21=21 blinks, pause, 21 blinks).

CAUTION

Before handling board, put on a static conductive wrist strap to protect against static discharge which can damage board. Follow instructions provided with wrist strap.

1. Turn main power OFF . Disconnect power supply.

Wait 5 minutes for stored voltage to discharge (E-30 and E-XP2 models only).

2. Relieve pressure, page 23.
3. Refer to electrical diagrams. Motor control board is on right side inside cabinet.
4. Put on static conductive wrist strap.
5. Disconnect all cables and connectors from board.
6. Remove nuts (40) and take entire motor control assembly to workbench.
7. Remove screws and take board off heatsink.
8. Set DIP switch (SW2) on new board. See TABLE 3 for factory settings. See FIG. 2 for location on board.

Table 3: DIP Switch (SW2) Settings

DIP Switch	Switch Position	
Switch 1	not used	
Switch 2	ON (up) for E-20 and E-30 models	OFF (down) for E-XP1 and E-XP2
Switch 3	ON (up) to enable pressure imbalance warning	OFF (down) to enable pressure imbalance alarm
Switch 4	not used	

9. Install new board in reverse order. Apply thermal heatsink compound to mating surfaces of board and heatsink.

 Order Part 110009 Thermal Compound.

Table 4: Motor Control Board Connectors

Model E-20 and E-XP1	Model E-30 and E-XP2	Pin	Description
J1	N, L	n/a	Main motor power
J8	J3	n/a	Transducer B
J4	J1	n/a	Motor output
J7	J6	1, 2	Motor thermal overload signal
		3	Brush wear signal
J3	J5	n/a	Transducer A
J10	J7	1-4	Not used
		5, 6	Cycle switch signal
		7-10	Jumper 15C866 (available in repair kit 246961)
J12	J12	n/a	Data reporting
J13	J13	n/a	To display board

24G879 Motor Control, for E-20 and E-XP1

DIP Switch (SW2) Settings

Model E-20

ON



TI3178b-3

Model E-XP1

ON



TI3178b-4

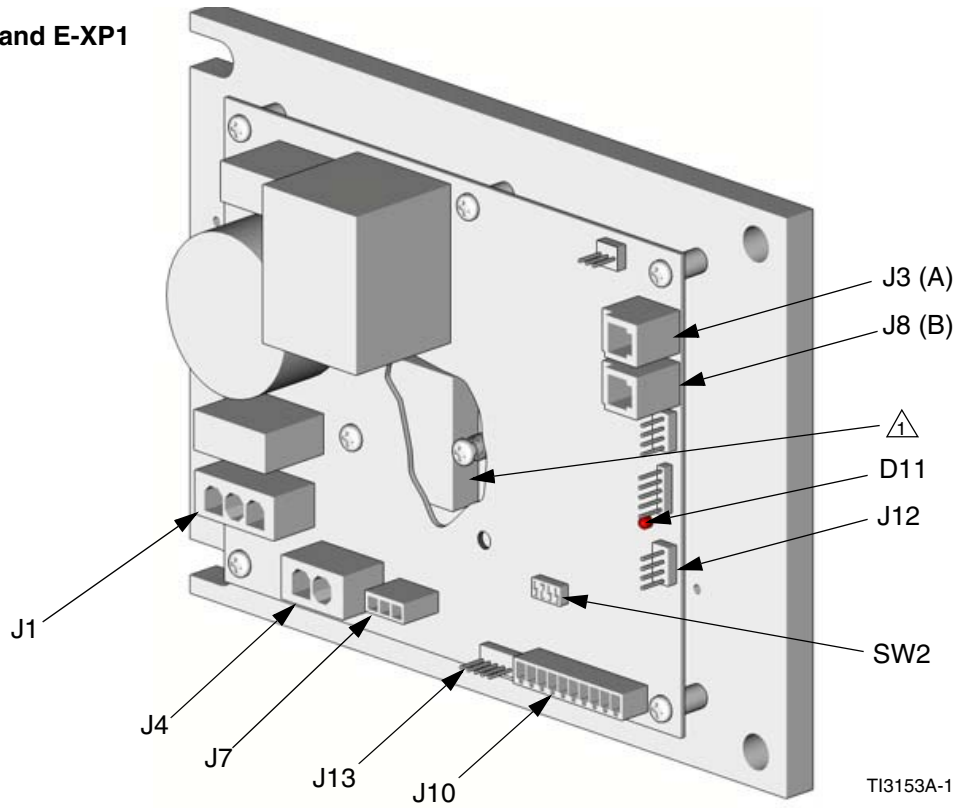

24G881 Motor Control, for E-30 and E-XP2

DIP Switch (SW2) Settings

Model E-30

1 2 3 4



TI3178b-2

Model E-XP2

1 2 3 4



TI3178b-1

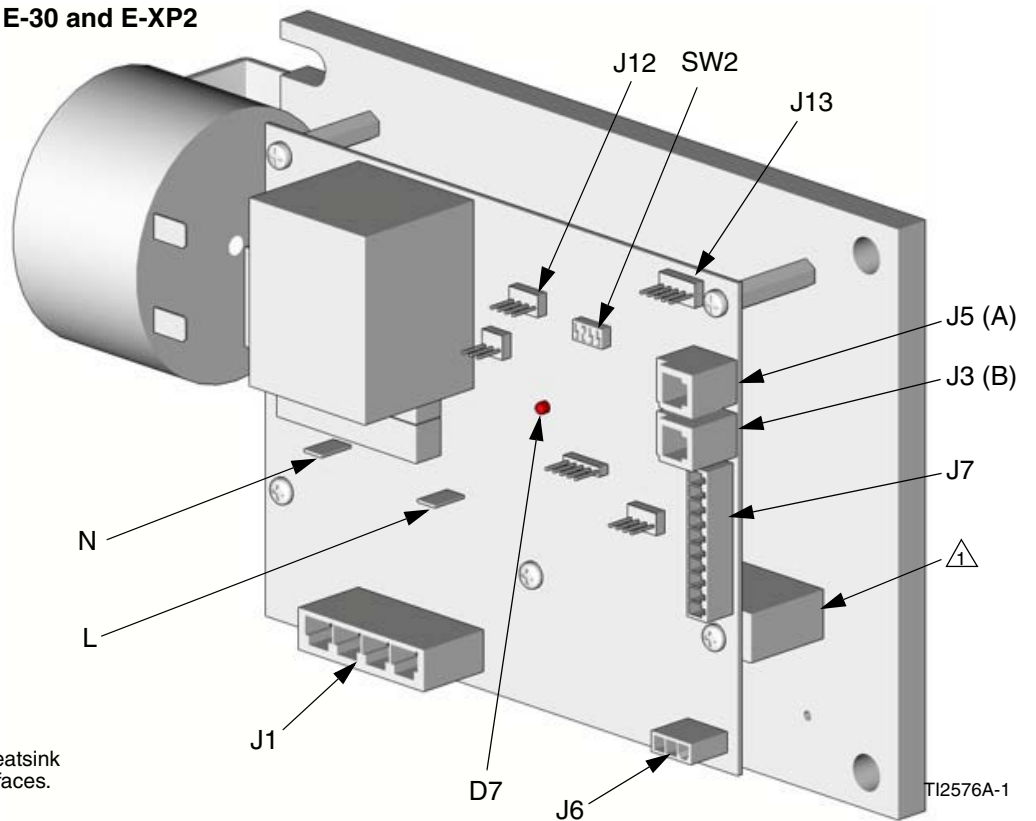

 Apply 110009 thermal heatsink compound to mating surfaces.

FIG. 2. Motor Control Board

Transducers

1. Turn main power OFF . Disconnect power supply.

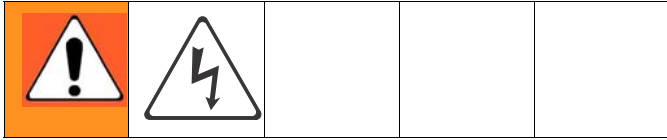

2. Relieve pressure, page 23.
3. Refer to electrical diagrams. Motor control board is on right side inside cabinet.

4. Disconnect transducer cables at board; see FIG. 2, page 35. Reverse A and B connections and check if diagnostic code follows; see **E21: No component A transducer**, page 12.
5. If transducer fails test, thread cable through top of cabinet. Note path as cable must be replaced in same way.
6. Install o-ring (820) on new transducer (806), FIG. 3.
7. Install transducer in manifold. Mark end of cable with tape (red=transducer A, blue=transducer B).
8. Route cable into cabinet and thread into bundle as before.
9. Connect transducer cable at board; see FIG. 2, page 35.

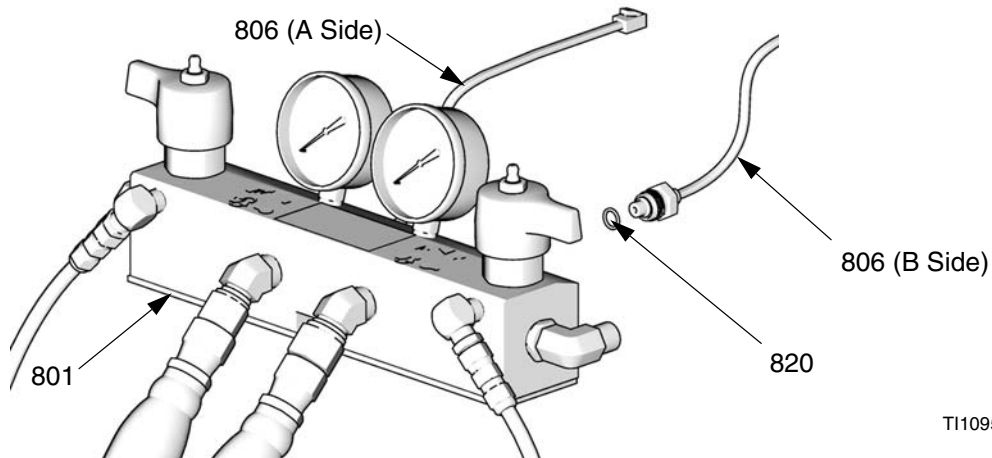

T110957a

FIG. 3. Transducers

Electric Fan

1. Turn main power OFF . Disconnect power supply.

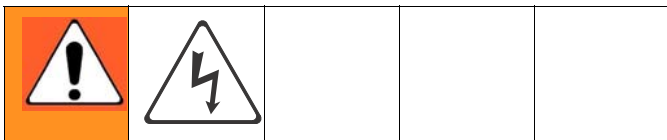

2. Relieve pressure, page 23.
3. Check fuses (F) at left of breaker module, FIG. 4. Replace if blown. If good, continue with step 4.

4. Refer to electrical diagrams. Disconnect fan wires from fuses (F).
5. Remove fan.
6. Install fan in reverse order.

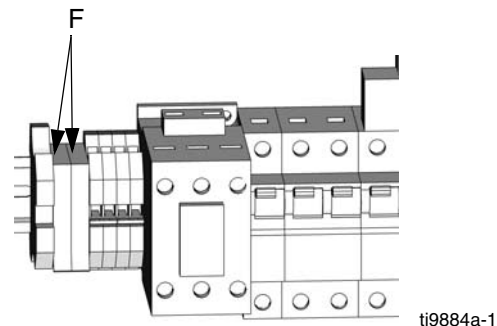

ti9884a-1

FIG. 4. Fan Fuses

Temperature Control Module

Table 5: Temperature Control Module Connections

Connector		Description
DATA (A)		Data reporting
SENSOR (B)	PIN	
	12	HOSE T/C P; FTS (purple)
	11	HOSE T/C R; FTS (red)
	10	HOSE T/C S; FTS (silver (unshielded bare wire))
	9	HEATER T/C B, Y; Thermocouple (yellow)
	8	HEATER T/C B, R; Thermocouple (red)
	7	Not used
	6	HEATER T/C A, Y; Thermocouple (yellow)
	5	HEATER T/C A, R; Thermocouple (red)
	4, 3	OVERTEMPERATURE B; Overtemperature switch B
2, 1	OVERTEMPERATURE A; Overtemperature switch A	
DISPLAY (C)		Display
COMMUNICATION (D)		Communication to power boards
PROGRAM (E)		Software programming
BOOT (F)		Software bootloader
POWER/RELAY (G)		Circuit board power input and contactor control output

Table 6: Temperature Power Module Connections

Connector	Description
COMMUNICATION (H)	Communication to control board
POWER (J)	Power to heater

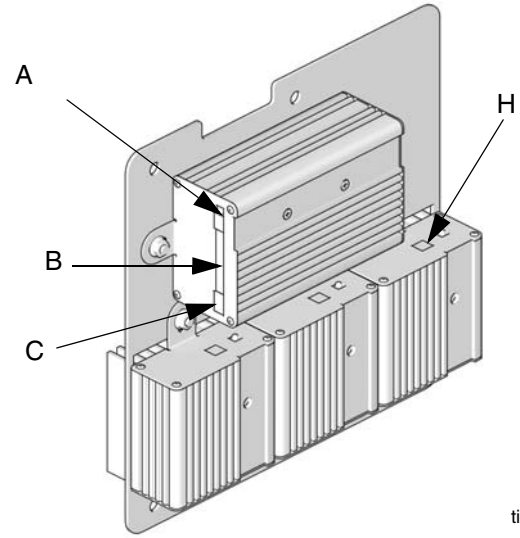

ti9875a

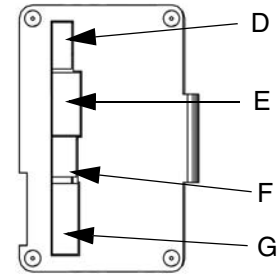

ti9843a1

Right Side of Control Heater Module

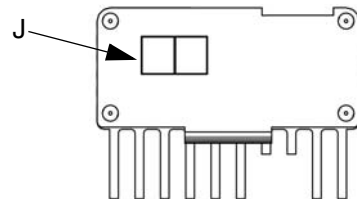





ti9843a4



Bottom of Power Modules

FIG. 5: Temperature Control Module Connections

Test SCR Circuit

1. Test the SCR circuit in the on position:
 - a. Make sure everything is connected, including the hose.
 - b. Turn main power ON  .
 - c. Adjust the hose heat setpoint **above** the ambient hose temperature.
 - d. Turn on  heat zone by pressing  .
 - e. Hold down  to view electrical current.

Hose current should ramp up to 45A. If there is no hose current, see **E03: No zone current**, page 10. If hose current exceeds 45A, see **E02: High zone current**, page 9. If hose current stays several amps below 45A, hose is too long or voltage is too low.

2. Test the SCR circuit in the off position:
 - a. Make sure everything is connected, including the hose.
 - b. Turn main power ON  .
 - c. Adjust the hose heat setpoint **below** the ambient hose temperature.
 - d. Turn on  heat zone by pressing  .
 - e. Using a voltmeter, carefully measure the voltage at the hose connector. You should not get a voltage reading. If you do, the SCR on the temperature control board is bad. Replace the temperature control assembly.

Replacing Temperature Control Assembly Modules

CAUTION
Before handling assembly, put on a static conductive wrist strap to protect against static discharge which can damage assembly. Follow instructions provided with wrist strap.

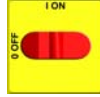
1. Turn main power OFF  . Disconnect power supply.

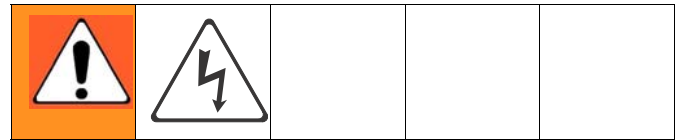

2. Relieve pressure, page 23.
3. Refer to electrical diagrams; see Electrical Diagrams manual 312067. Temperature control assembly is on left side inside cabinet.
4. Remove bolts that secure transformer assembly and slide assembly to side in cabinet.
5. Put on static conductive wrist strap.
6. Disconnect all cables and connectors from assembly; see **Parts - Temperature Control**, page 64.
7. Remove nuts and take entire temperature control assembly to workbench.
8. Replace defective module.
9. Install assembly in reverse order.

Primary Heaters

Heater Element



Line Voltage

The primary heaters output their rated wattage at 230 Vac. Low line voltage will reduce power available and the heaters will not perform at full capability.

1. Turn main power OFF  . Disconnect power supply.
2. Relieve pressure, page 23.
3. Wait for heaters to cool.
4. Remove heater shroud.
5. See FIG. 6. Disconnect heater element wires from heater wire connector. Test with ohmmeter.

Total Heater Wattage	Element	Ohms
6,000	1500	30-35
7,650	2550	18-21
10,200	2550	18-21

6. To remove heater element, first remove thermocouple (310) to avoid damage, see step 7, page 42.
7. Remove heater element (307) from housing (301). Be careful not to spill any fluid left in housing.
8. Inspect element. It should be relatively smooth and shiny. If there is a crusted, burnt, ash-like material adhered to element or sheath shows pitting marks, replace element.
9. Install new heater element (307), holding mixer (309) so it does not block thermocouple port (P).
10. Reinstall thermocouple, page 42.
11. Reconnect heater element leadwires to heater wire connector.
12. Replace heater shroud.

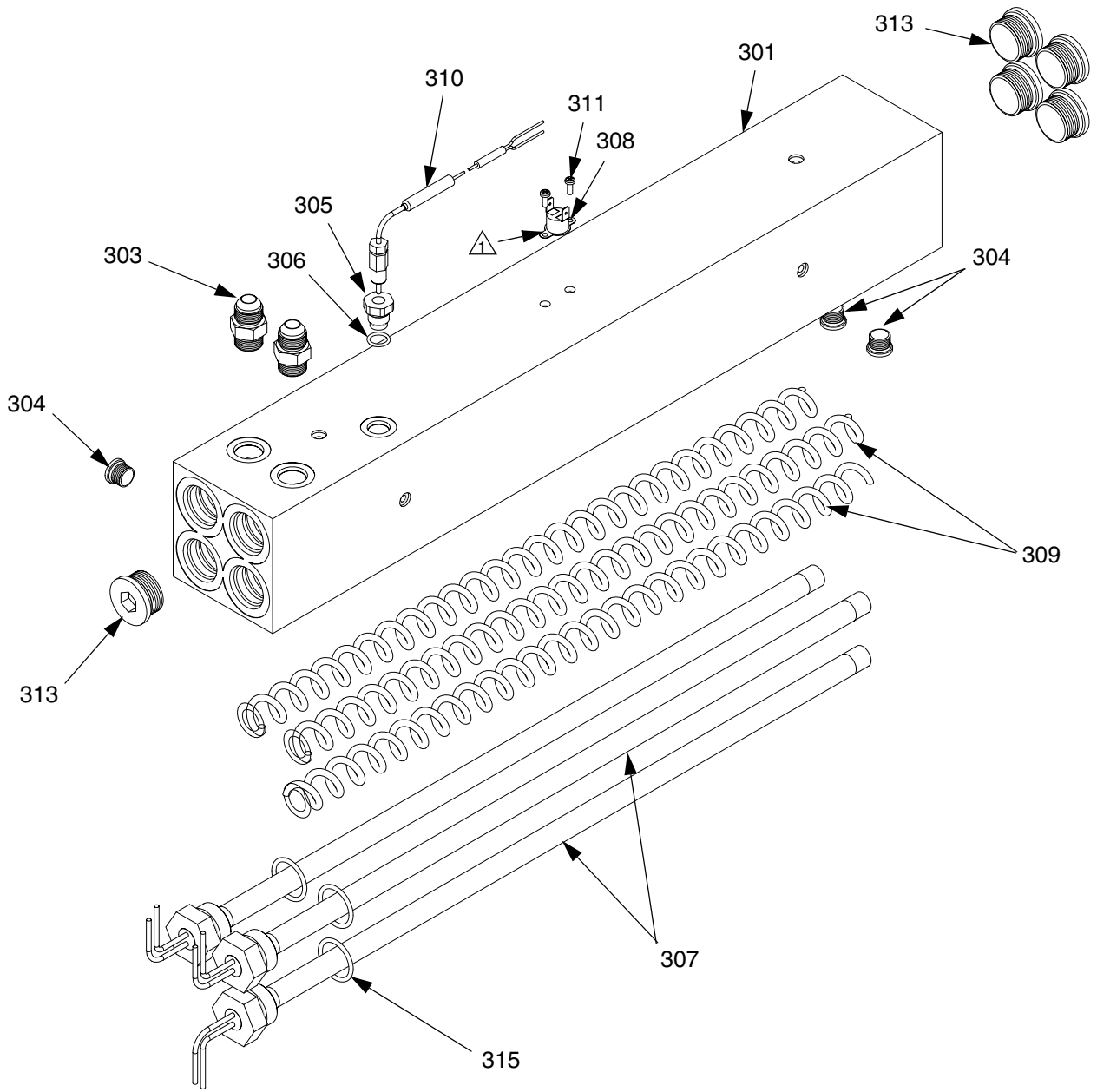

r_247813_312066

 Apply 110009 thermal heatsink compound.

FIG. 6. Heater (7.5 kW Single Zone Heater Shown)

Thermocouple

1. Turn main power OFF . Disconnect power supply.

2. Relieve pressure, page 23.

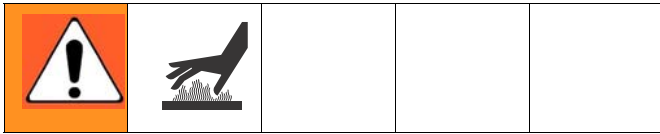

3. Wait for heaters to cool.

4. Remove heater shroud.

5. Disconnect thermocouple wires from B on temperature control module. See TABLE 5, page 37 and FIG. 5, page 37.

6. Feed thermocouple wires out of cabinet. Note path as wires must be replaced in the same way.

7. See FIG. 7. Loosen ferrule nut (N). Remove thermocouple (310) from heater housing (301), then remove thermocouple housing (H). Do not remove the thermocouple adapter (305) unless necessary. If

adapter must be removed, ensure that mixer (309) is out of the way when replacing the adapter.

8. Replace thermocouple, FIG. 7.

a. Remove protective tape from thermocouple tip (T).

b. Apply PTFE tape and thread sealant to male threads and tighten thermocouple housing (H) into adapter (305).

c. Push in thermocouple (310) so tip (T) contacts heater element (307).

d. Holding thermocouple (T) against heater element, tighten ferrule nut (N) 1/4 turn past tight.

9. Route wires (S) into cabinet and thread into bundle as before. Reconnect wires to board.

10. Replace heater shroud.

11. Turn on heaters A and B simultaneously to test. Temperatures should rise at same rate. If one heater is low, loosen ferrule nut (N) and tighten thermocouple housing (H) to ensure thermocouple tip (T) contacts element (307).

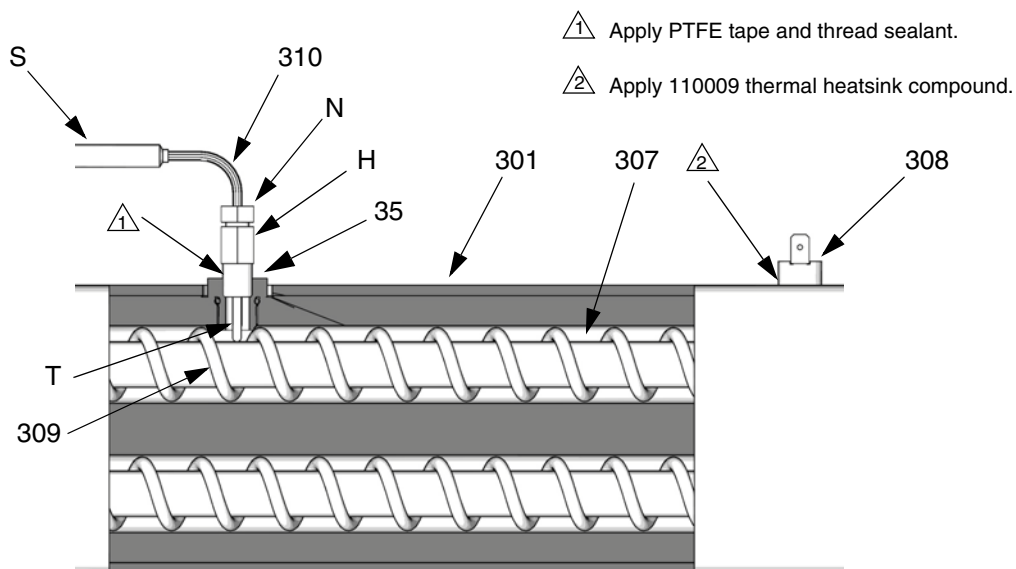

ti7924a

FIG. 7. Thermocouple

Overtemperature Switch

1. Turn main power OFF . Disconnect power supply.
2. Relieve pressure, page 23.



3. Wait for heaters to cool.
4. Remove heater shroud.
5. Disconnect one leadwire from overtemperature switch (308), FIG. 7. Test across switch with ohmmeter. Resistance must be approximately 0 ohms.
6. If switch fails test, remove wires and screws. Discard failed switch. Apply thermal compound 110009, install new switch in same location on housing (301), and secure with screws (311). Reconnect wires.

 If wires need replacement, disconnect from temperature control board. See TABLE 5, page 37 and FIG. 5, page 37.

Heated Hose

 Refer to the heated hose manual 309572 for hose replacement parts.

Check Hose Connectors

1. Turn main power OFF . Disconnect power supply.
2. Relieve pressure, page 23.

 Whip hose must be connected.

3. Disconnect hose connector (D) at Reactor, FIG. 8.

4. Using an ohmmeter, check between the two terminals of the connector (D). There should be continuity.
5. If hose fails test, retest at each length of hose, including whip hose, until failure is isolated.

Check FTS Cables

1. Turn main power OFF . Disconnect power supply.
2. Relieve pressure, page 23.
3. Disconnect FTS cable (F) at Reactor, FIG. 8.

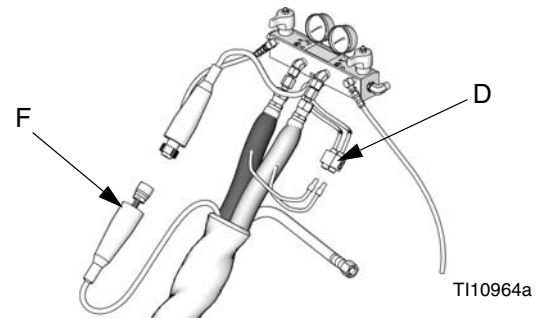

FIG. 8. Heated Hose

4. Test with ohmmeter between pins of cable connector.

Pins	Result
1 to 2	approximately 35 ohms per 50 ft (15.2 m) of hose, plus approximately 10 ohms for FTS
1 to 3	infinity

5. If cable fails test, retest at FTS, page 44.

Fluid Temperature Sensor (FTS)

Test/Removal

1. Turn main power OFF . Disconnect power supply.
2. Relieve pressure, page 23.
3. Remove tape and protective covering from FTS (21), FIG. 8. Disconnect hose cable (F). Test with ohmmeter between pins of cable connector.

Pins	Result
1 to 2	approximately 10 ohms
1 to 3	infinity
3 to FTS groundscrew	0 ohms
1 to FTS component A fitting (ISO)	infinity

4. If FTS fails any test, replace FTS.
5. Disconnect air hoses (C, L), and electrical connectors (D).
6. Disconnect FTS from whip hose (W) and fluid hoses (A, B).
7. Remove ground wire (K) from ground screw on underside of FTS.
8. Remove FTS probe (H) from component A (ISO) side of hose.

Installation

The Fluid Temperature Sensor (FTS) is supplied. Install FTS between main hose and whip hose. See Heated Hose manual 309572 for instructions.

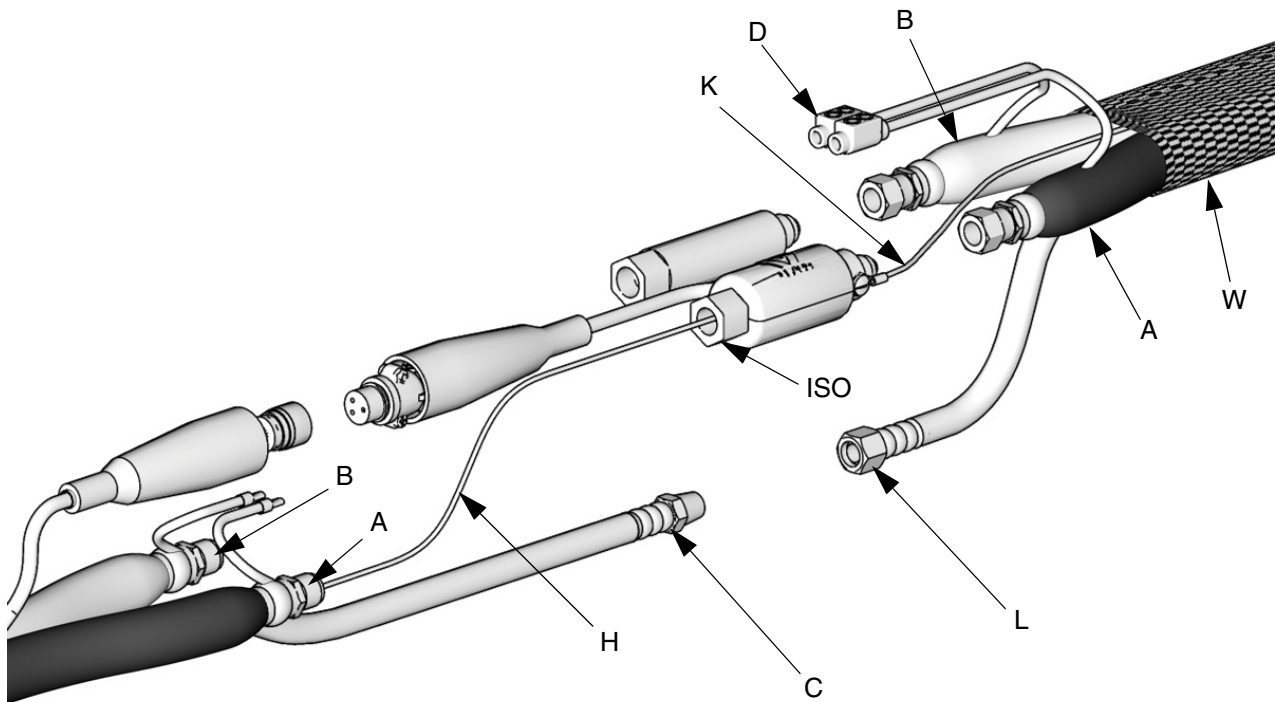

ti9581c

FIG. 9: Fluid Temperature Sensor and Heated Hoses

Transformer Primary Check

1. Turn main power OFF .
2. Locate the two smaller (10 AWG) wires coming out of transformer. Trace these wires back to contactor and circuit breaker (911). Use an ohmmeter to test for continuity between two wires; there should be continuity.

Transformer Secondary Check

1. Turn main power OFF .
2. Locate the two larger (6 AWG) wires coming out of transformer. Trace these wires back to large green connector under hose control module and circuit breaker (909). Use an ohmmeter to test for continuity between two wires; there should be continuity.

If you are not sure which wire in green plug under hose module connects to transformer, test both wires. One wire should have continuity with the other transformer wire in breaker (909) and the other wire should not.

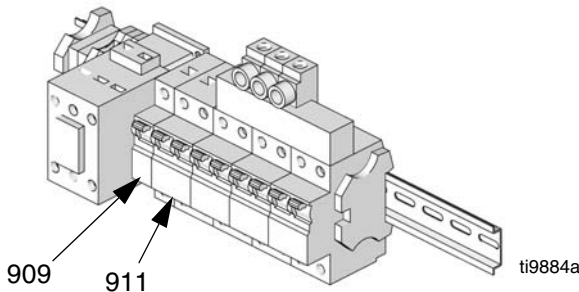



FIG. 10: Circuit Breaker Module

3. To verify transformer voltage, turn on hose zone. Measure voltage from 18CB-2 to POD-HOSE-P15-2; see Reactor Electrical Diagrams manual 312067.

Model	Secondary Voltage
310 ft.	90 Vac*
210 ft.	62 Vac*

* For 230 Vac line voltage.

Replace Transformer

 Use this procedure to replace transformer.

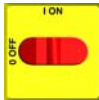
1. Turn main power OFF . Disconnect power supply.

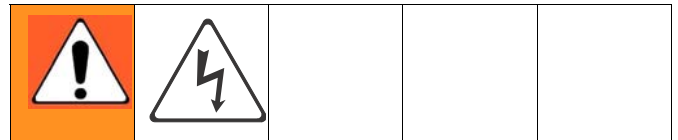

2. Open Reactor cabinet.
3. Remove bolts holding transformer to cabinet floor. Slide transformer forward.
4. Disconnect the transformer wires; see Reactor Electrical Diagrams manual 312067.
5. Remove transformer from cabinet.
6. Install new transformer in reverse order.

Display Module

Temperature and Pressure Displays

CAUTION
Before handling board, put on a static conductive wrist strap to protect against static discharge which can damage board. Follow instructions provided with wrist strap.

1. Turn main power OFF . Disconnect power supply.

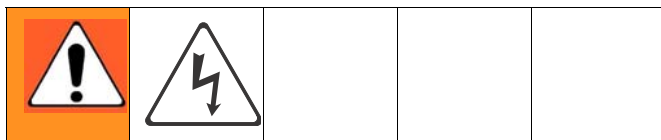

2. Relieve pressure, page 23.
3. Refer to electrical diagrams.
4. Put on static conductive wrist strap.
5. Disconnect main display cable (20) at lower left corner of display module; see FIG. 11.
6. Remove screws (509, 510) and cover (504); see FIG. 11.

 If replacing both displays, label temperature display cables TEMP and pressure display cables PUMP before disconnecting.

7. Disconnect cable connectors (506 and 511) from back of temperature display (501) or pressure display (502); see FIG. 11.
8. Disconnect ribbon cable(s) (R) from back of display; see FIG. 11.
9. Remove nuts (508) and plate (505).
10. Disassemble display, see detail in FIG. 11.
11. Replace board (501a or 502a) or membrane switch (501b or 502b) as necessary.
12. Reassemble in reverse order, see FIG. 11. Apply medium strength thread sealant where shown. Be sure display cable ground wire (G) is secured

between cable bushing and cover (504) with screws (512).

Red Stop Button

CAUTION
Before handling board, put on a static conductive wrist strap to protect against static discharge which can damage board. Follow instructions provided with wrist strap.

1. Turn main power OFF . Disconnect power supply.

2. Relieve pressure, page 23.
3. Refer to electrical diagrams.
4. Put on static conductive wrist strap.
5. Remove screws (509, 510) and cover (504), FIG. 11.
6. Disconnect button cable connectors (506) from back of temperature display (501) and pressure display (502).
7. Remove red stop button (506).
8. Reassemble in reverse order. Be sure display cable ground wire (G) is secured between cable bushing and cover (504) with screws (512).

⚠ Apply medium strength thread sealant.

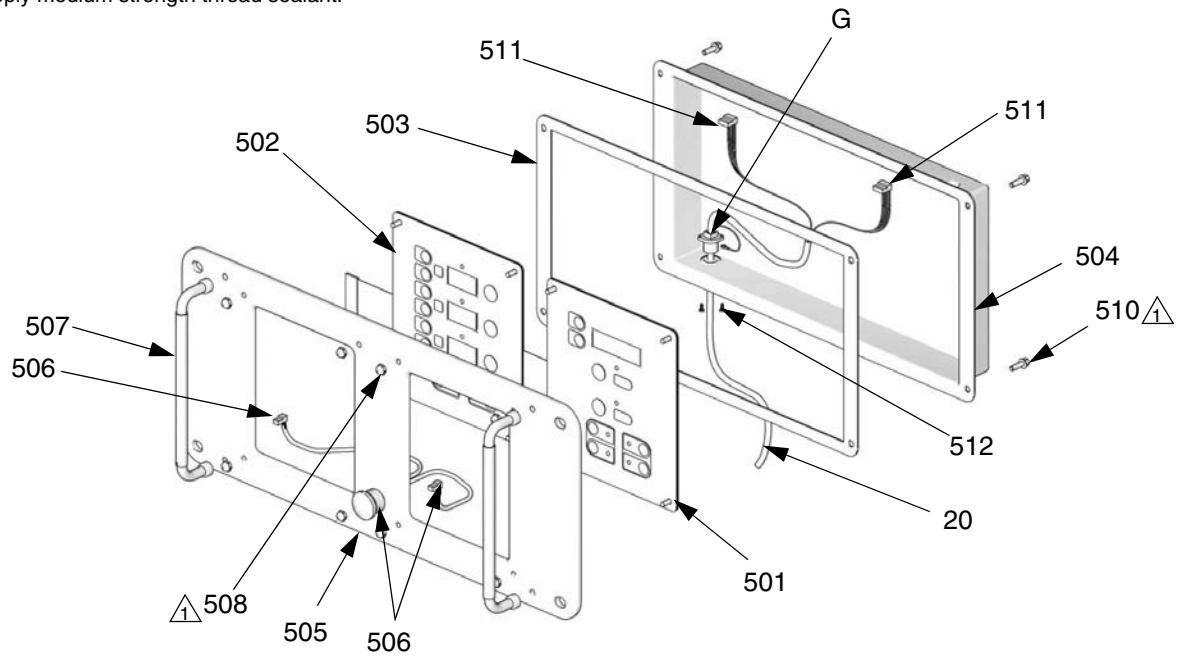

ti2574a

Detail of Membrane Switches and Display Boards

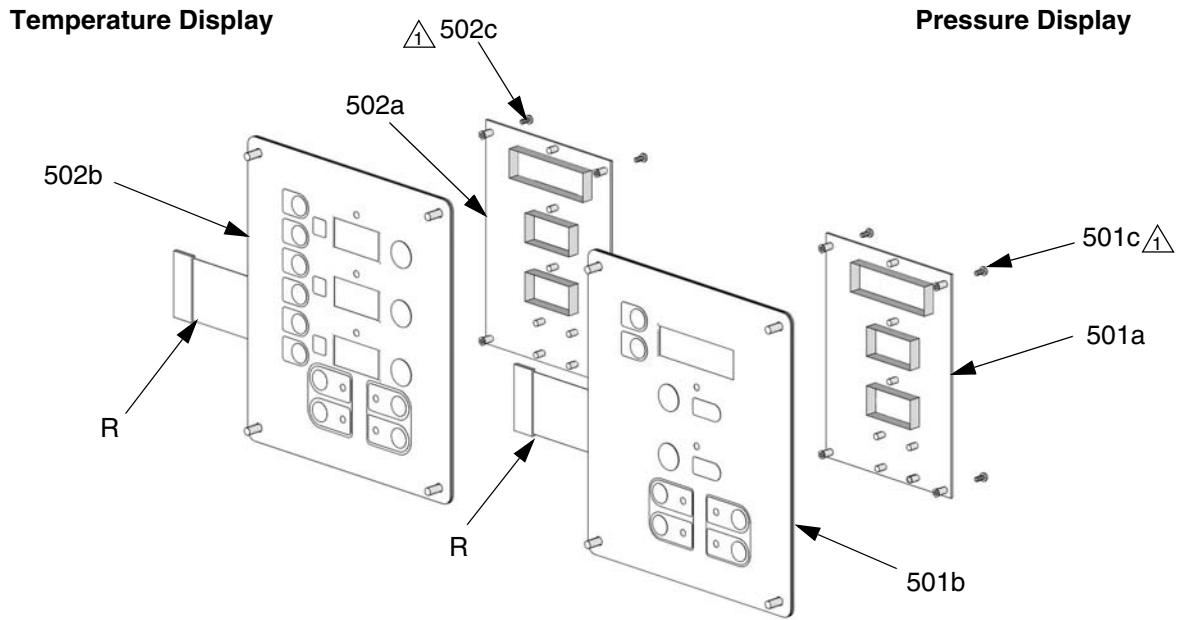

ti3172a

FIG. 11. Display Module

Inlet Fluid Strainer Screen

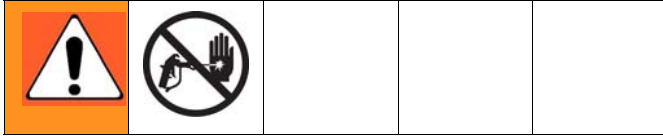

The inlet strainer at each proportioning pump filters out solid matter that can plug the inlet check valves. Inspect the screens daily as part of the startup routine, and clean as required.

Isocyanate can crystallize from moisture contamination or from freezing. If the chemicals used are clean and proper storage, transfer, and operating procedures are followed, there should be minimal contamination of the A-side screen.

 Clean the A-side screen only during daily startup. This minimizes moisture contamination by immediately flushing out any isocyanate residue at the start of dispensing operations.

1. Close the material supply valve at the pump inlet to prevent material from being pumped while the strainer plug (C) is removed.
2. Place a container under the strainer base to catch drain off when removing the strainer plug.
3. Remove the screen (A) from the strainer manifold. Thoroughly flush the screen with gun cleaner and shake it dry. Inspect the screen for blockage. No more than 25% of the mesh should be restricted. If more than 25% is blocked, replace the screen. Inspect the strainer gasket (B) and replace as required.
4. Ensure the pipe plug (D) is securely screwed into the strainer plug (C). Install the strainer plug with the screen (A) and gasket (B) in place and tighten. Do not overtighten. Let the gasket make the seal.
5. Open the material supply valve, ensure that there are no leaks, and wipe the equipment clean.
6. Proceed with operation.

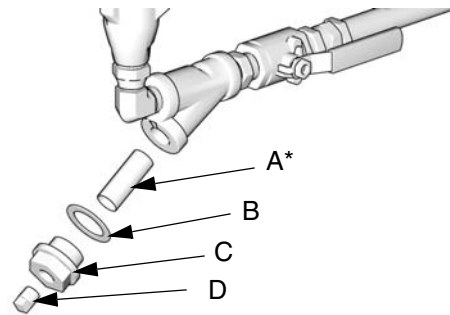

TI10974a

FIG. 12. Y Strainer Components

* Fluid filter screen (59g) replacements:

Part	Description
180199	20 mesh (standard); 1 pack
255082	80 mesh (optional); 2 pack
255083	80 mesh (optional); 10 pack

Pump Lubrication System



Check the condition of the ISO pump lubricant daily. Change the lubricant if it becomes a gel, its color darkens, or it becomes diluted with isocyanate.

Gel formation is due to moisture absorption by the pump lubricant. The interval between changes depends on the environment in which the equipment is operating. The pump lubrication system minimizes exposure to moisture, but some contamination is still possible.

Lubricant discoloration is due to continual seepage of small amounts of isocyanate past the pump packings during operation. If the packings are operating properly, lubricant replacement due to discoloration should not be necessary more often than every 3 or 4 weeks.

To change pump lubricant:

1. Relieve pressure, page 23.
2. Lift the lubricant reservoir (LR) out of the bracket (RB) and remove the container from the cap. Holding the cap over a suitable container, remove the inlet check valve and allow the lubricant to drain. Reattach the inlet check valve to the inlet hose. See FIG. 13.

3. Drain the reservoir and flush it with clean lubricant.
4. When the reservoir is flushed clean, fill with fresh lubricant.
5. Thread the reservoir onto the cap assembly and place it into the bracket.
6. The lubrication system is ready for operation. No priming is required.

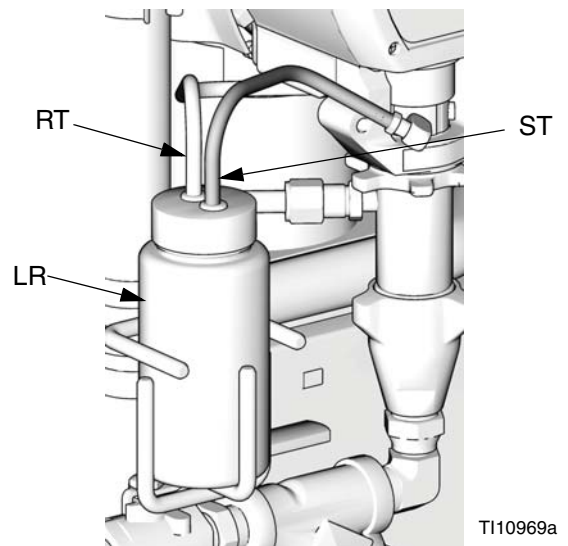
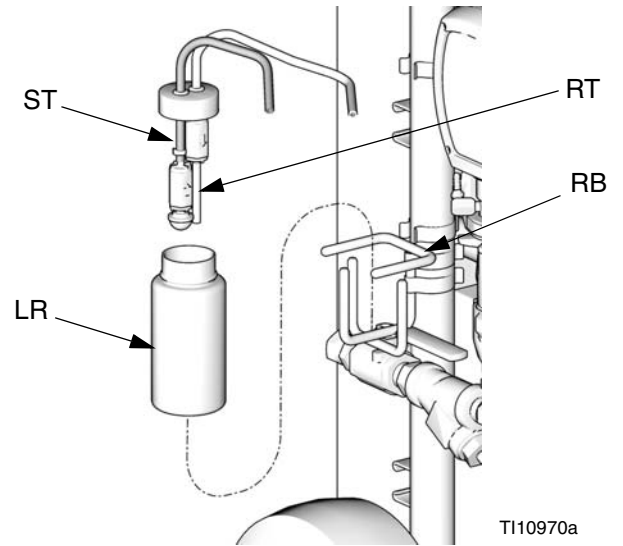
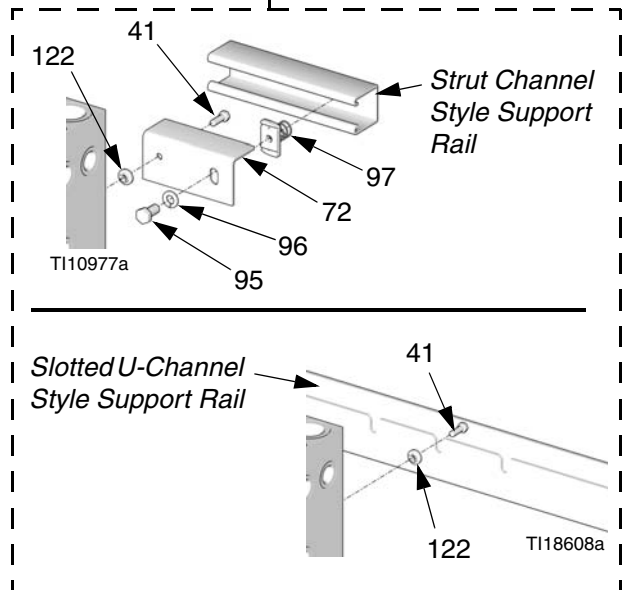
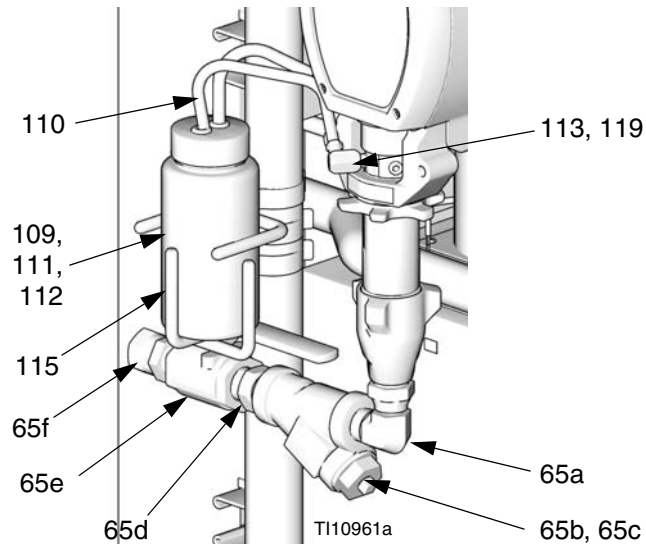
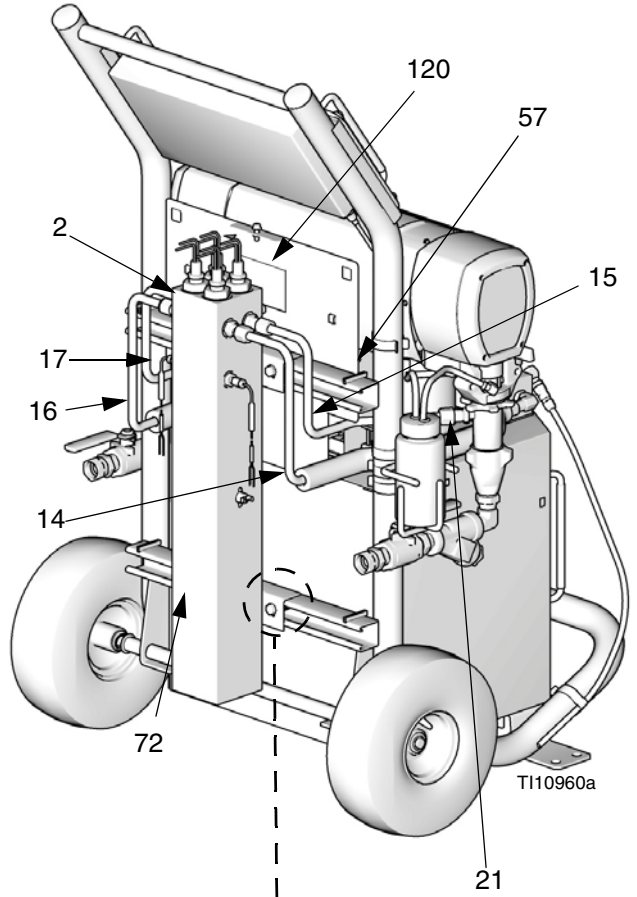
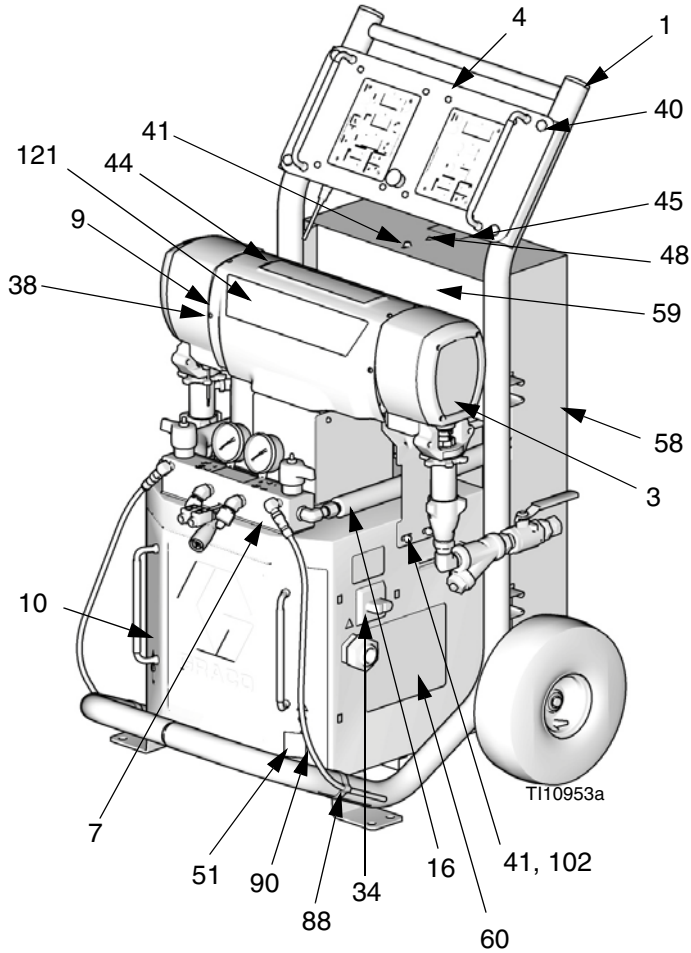

FIG. 13. Pump Lubrication System

Parts

Reactor Assembly (Model E-XP1 Shown)



Left Side of Cabinet

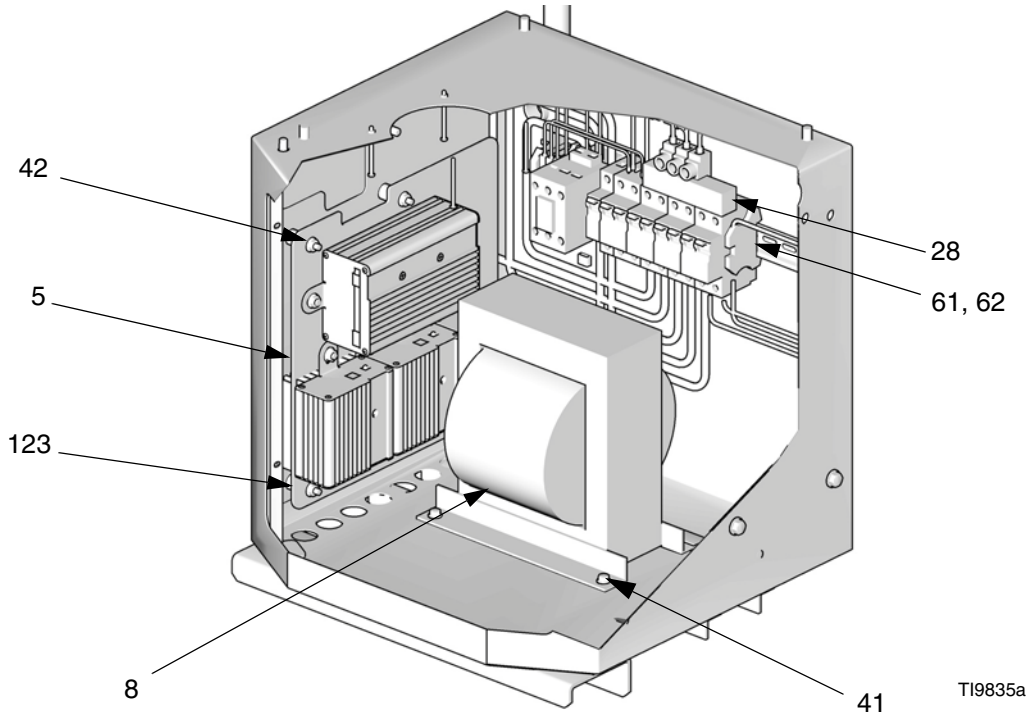

Right Side of Cabinet

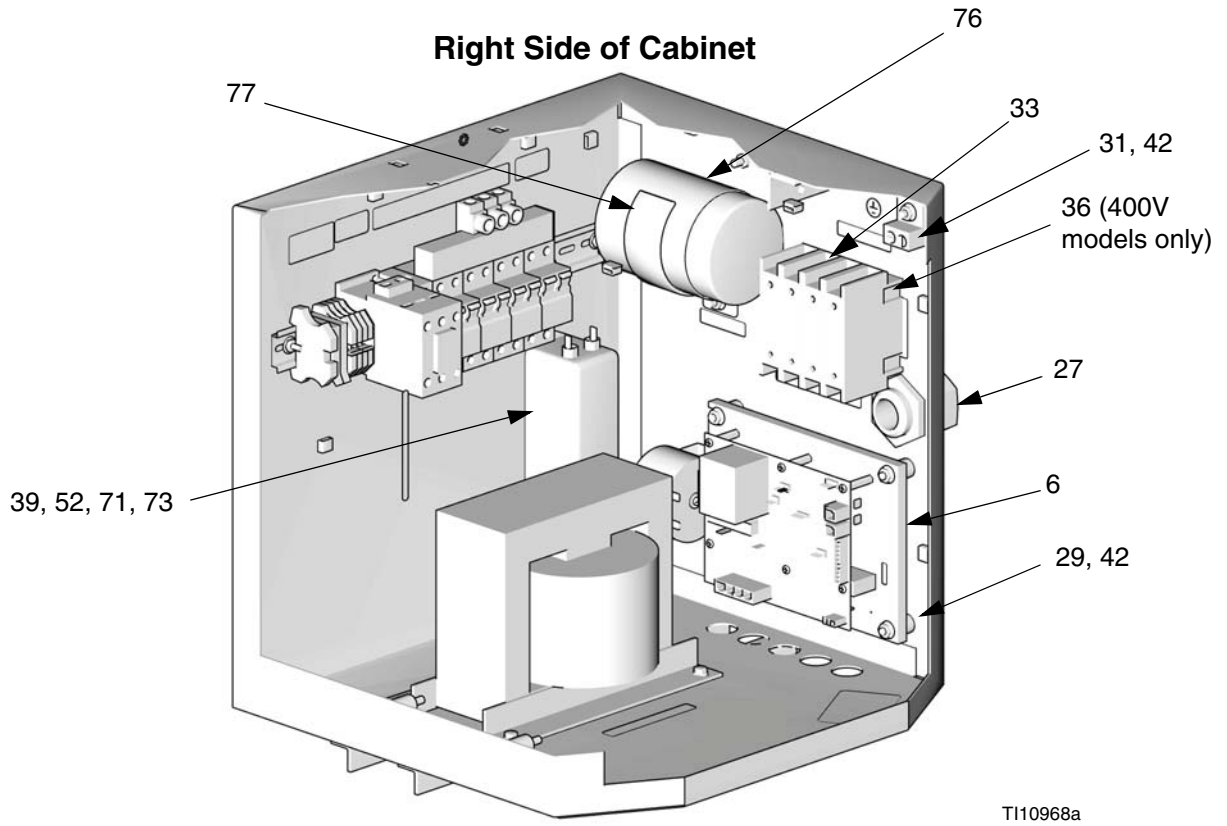

Detail, Fluid Manifold Area

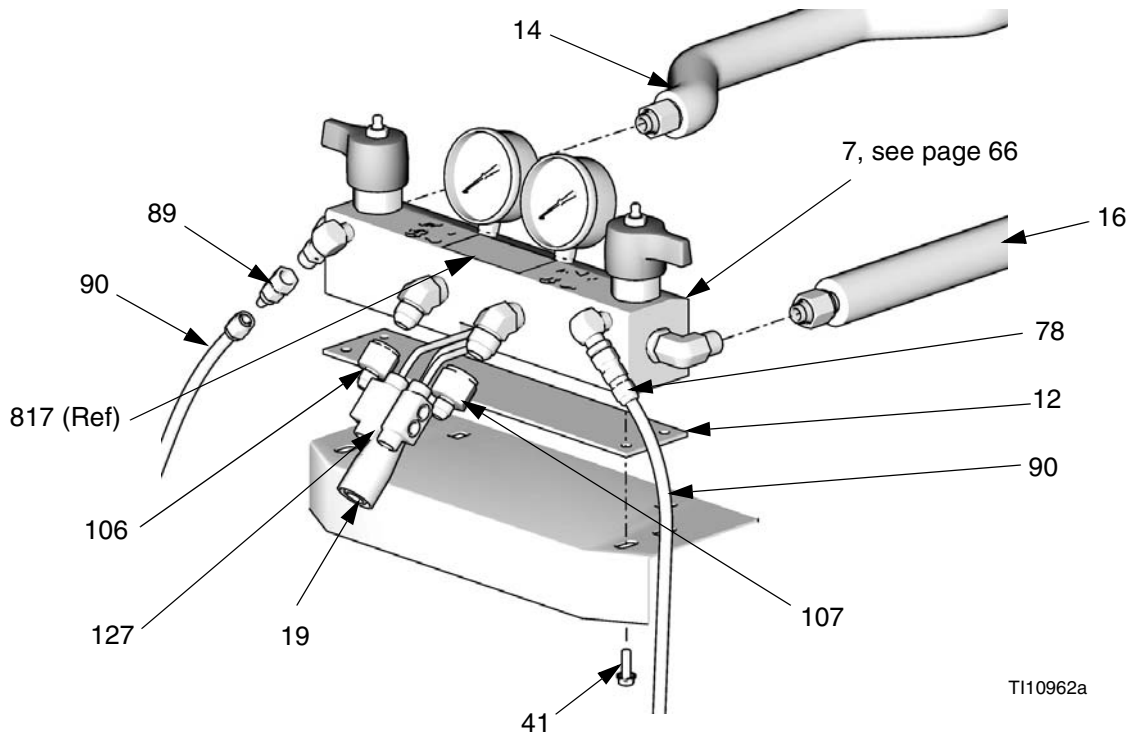

T110962a

Detail, Cabinet Area

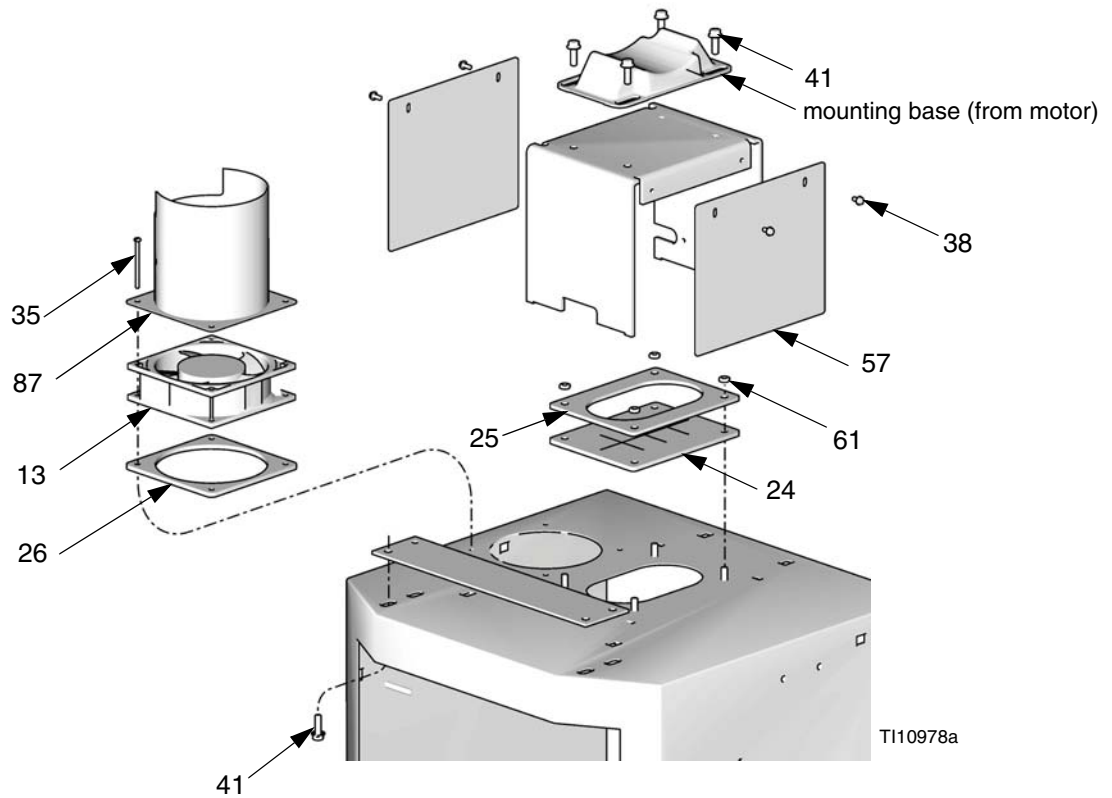

T110978a

Parts Used on All Models

See pages 54 through 56 for parts that vary by model.

Ref.	Part	Description	Qty	Ref.	Part	Description	Qty
1		FRAME; page 62	1	65e	109077	VALVE, ball; 3/4 npt (fbe)	2
2		HEATER; pages 60 and 61	*	65f	118459	FITTING, union, swivel; 3/4-14 npt(m) x 3/4-14 npt(f)	2
3		MODULE, proportioner; page 58	*	66	101078	Y-STRAINER; includes 66a	2
4	245974	DISPLAY; page 63	1	66a†	180199	ELEMENT, 20 mesh	1
5		CONTROL, temperature; page 64	1	67	109077	VALVE, ball; 3/4 npt (fbe)	2
6		CONTROL, motor; page 65	*	68	C20487	NIPPLE; 3/4 npt	2
7	247823	MANIFOLD, fluid; page 66	1	69	157785	UNION, swivel; 3/4 npt(m) x 3/4 npsm(f)	2
8		TRANSFORMER; pages 54-56	*	71		SCREW, machine; pages 54-56	*
9		SHIELD; page pages 54-56	*	72◆		BRACKET, heater; pages 54-56	*
10	246976	DOOR, cabinet	1	73		WASHER, lock; pages 54-56	*
11†	261669	SENSOR, fluid temperature	1	76		CAPACITOR; pages 54-56	*
12	15B456	GASKET, manifold	1	77		BRACKET; pages 54-56	*
13	115834	FAN	1	86		CABLE, overtemperature, jumper; pages 54-56	*
14		TUBE, heater component A; pages 54-56	*	87	15B807	SHIELD, fan	1
15		TUBE, pump, component A; pages 54-56	*	88	186494	CLIP, spring	6
16		TUBE, heater component B; pages 54-56	*	89	205447	COUPLING, hose	2
17		TUBE, pump, component B; pages 54-56	*	90	15M338	TUBE, low pressure; 1/4 in. (6 mm) ID; 3/8 in. (16 mm) OD; 4 ft (1.2 m); PTFE	1
18†	247787	CABLE, overtemperature; see electrical diagrams	1	95◆		BOLT; hex hd; pages 54-56	*
19†	15B380	CABLE, hose control; see electrical diagrams	1	96◆		LOCKWASHER; 3/8; pages 54-56	*
20	15B383	CABLE, display	1	97◆		NUT, channel; pages 54-56	*
21		CONNECTOR, tube; pages 54-56	*	102		STRAP, motor; pages 54-56	*
22	116773	CONNECTOR, plug	1	106	117502	REDUCER; #5 x #8 JIC	1
23	C38163	WASHER, lock, external tooth	1	107	117677	REDUCER; #6 x #10 JIC	1
24	15B361	BOOT, wire feed through	1	109	246928	RESERVOIR; includes 110-119; see 309911	1
25	15B510	PLATE, cover, wire	1	110	054826	TUBE; PTFE; 1/4 in. (6 mm) ID; 2 ft (0.6 m)	2
26	15B360	GASKET, fan	1	111	118433	VALVE, check	1
27	255047	STRAIN RELIEF	1	112	118432	VALVE, check	1
28		MODULE, breaker; pages 54-56	*	113	116746	FITTING, barbed	2
29	116149	SPACER	8	115	15C568	BRACKET, reservoir	1
31	117666	TERMINAL, ground	1	117	206995	THROAT SEAL LIQUID; 1 qt (1 liter)	1
33★	123969	SWITCH, disconnect	1	119	191892	ELBOW; 1/8 npt (m x f)	2
34★	123967	SWITCH, main power	1	120▲	171001	LABEL, warning	1
35	117723	SCREW, machine; 6-32 x 2 in. (51 mm)	4	121		LABEL; pages 54-56	*
36		SWITCH, added pole; 380V; page 54	*	122		INSULATOR, heat; pages 54-56	*
38	115492	SCREW, machine; 8-32 x 0.345 in. (9 mm)	13	123	247782	SPACER	4
39		FILTER; 230V; page 54	*	124	247854	COVER, connector, module	1
40	117623	NUT, cap; 3/8-16	4	125	114331	SCREW, machine; 6-32 x 0.375 in. (9.5 mm)	2
41	113796	SCREW, flanged, hex hd; 1/4-20 x 3/4 in. (19 mm)	15				
42	115942	NUT, hex flange; 1/4-20	15				
44	15K817	LABEL, diagnostic codes	1				
45	189930	LABEL, caution	3				
48▲	189285	LABEL, caution	3				
51▲		LABEL, warning; pages 54-56	*				
52		CABLE, harness, filter; pages 54-56	*				
53	15B593	SHIELD, membrane switch; pack of 10	1				
57	15B775	COVER, wire access	2				
58	247524	COVER, heater, back	1				
59	256732	COVER, heater, front	1				
60▲	15G280	LABEL, warning	1				
61	113505	NUT, hex, keps; 10-24	6				
62	112776	WASHER, plain; no. 10	2				
65		KIT, fluid inlet	1				
65a		FITTING, swivel, elbow	2				
65b	101078	Y-STRAINER	2				
65c†	180199	ELEMENT, 20 mesh	2				
65d	C20487	NIPPLE, 3/4 npt	2				

▲ Replacement Danger and Warning labels, tags, and cards are available at no cost.

* See quantity on referenced pages.

† Not shown.

★ Required for all A-D series models. Included in Knob Repair Kit 258920 (purchase separately).

◆ Not required for slotted U-Channel style heater support rails.

Parts that Vary by Model

Use the following tables on this and the next two pages to find parts that vary by model. Find the reference number and of part in left column and Reactor model in top row. Intersection is correct part number.

See page 53 for parts common to all models.

Ref.	Description	Reactor Models												Qty
		259024 E-XP1	259025 E-20	259026 E-30	259028 E-XP2	259029 E-XP1	259030 E-20	259031 E-30	259032 E-XP2	259033 E-XP1	259034 E-20	259035 E-30	259036 E-XP2	
2	HEATER; pages 60 and 61	247507	247506	247507	247509 (qty: 2)	247507	247506	247507	247509 (qty: 2)	247507	247506	247507	247509 (qty: 2)	1
3	MODULE, proportioner; page 58	245956	245956	245957	245959	245956	245956	245957	245959	245956	245956	245957	245959	1
6	CONTROL, motor; page 65	24G879	24G879	24G881	24G881	24G879	24G879	24G881	24G881	24G879	24G879	24G881	24G881	1
8	TRANSFORMER;	247840	247840	247812	247812	247840	247840	247812	247812	247840	247840	247812	247812	1
9	SHIELD	276878	276878	276879	276879	276878	276878	276879	276879	276878	276878	276879	276879	1
14	TUBE, heater, component A	247920	247920	247920	247915	247920	247920	247920	247915	247920	247920	247920	247915	1
15	TUBE, pump, component A	247912	247912	247919	247914	247912	247912	247919	247914	247912	247912	247919	247917	1
16	TUBE, heater, component B	247918	247918	247918	247917	247918	247918	247918	247917	247918	247918	247918	247917	1
17	TUBE, pump, component B	247913	247913	247921	247916	247913	247913	247921	247916	247913	247913	247921	247916	1
21	CONNECTOR, tube	121310	121310	121311	121311	121310	121310	121311	121311	121310	121310	121311	121311	2
28	MODULE, breaker; page 67	C	C	F	F	B	B	E	E	A	A	D	D	1
36	SWITCH, added pole; 380V					123968	123968	123968	123968					1
39	FILTER; 230V			117667	117667			117667	117667			117667	117667	1

Ref.	Description	Reactor Models											Qty	
		259024 E-XP1	259025 E-20	259026 E-30	259028 E-XP2	259029 E-XP1	259030 E-20	259031 E-30	259032 E-XP2	259033 E-XP1	259034 E-20	259035 E-30		259036 E-XP2
51▲	LABEL, warning			198278	198278			198278	198278			198278	198278	1
52	CABLE, harness, filter			15B385	15B385			15B385	15B385			15B385	15B385	1
65	KIT, fluid inlet	234366	234366	234367	234366	234366	234366	234367	234366	234366	234366	234367	234366	1
65a	ELBOW, swivel; 3/4 npt(m) x 1" npt(f)	160327	160327	118463	160327	160327	160327	118463	160327	160327	160327	118463	160327	2
71	SCREW, machine			---	---			---	---			---	---	2
72◆	BRACKET, heater	247523	247523	247523		247523	247523	247523		247523	247523	247523		2
	BRACKET, heater				247523				247523				247523	4
73	WASHER, lock			103181	103181			103181	103181			103181	103181	2
76	CAPACITOR			244733	244733			244733	244733			244733	244733	1
77	BRACKET			197999	197999			197999	197999			197999	197999	1
86	CABLE, over- temperature, jumper	15H187	15H187	15H187		15H187	15H187	15H187		15H187	15H187	15H187		1
95◆	BOLT; hex hd; 3/8-16	100469	100469	100469		100469	100469	100469		100469	100469	100469		2
	BOLT; hex hd; 3/8-16				100469				100469				100469	4
96◆	LOCKWASHER; 3/8	100133	100133	100133		100133	100133	100133		100133	100133	100133		2
	LOCKWASHER; 3/8				100133				100133				100133	4
97◆	NUT, channel	118446	118446	118446		118446	118446	118446		118446	118446	118446		2
	NUT, channel				118446				118446				118446	4
102	STRAP, motor	15B107	15B107	15B108	15B108	15B107	15B107	15B108	15B108	15B107	15B107	15B108	15B108	1
121	LABEL	15M504	15M500	15M499	15M501	15M504	15M500	15M499	15M501	15M504	15M500	15M499	15M501	1
122	INSULATOR	167002	167002	167002	167002 (qty: 4)	167002	167002	167002	167002 (qty: 4)	167002	167002	167002	167002 (qty: 4)	2

Parts that Vary by Model (continued)

Ref.	Description	Reactor Models			Qty
		259057 E-30 w/15.3kW	259058 E-30 w/15.3kW	259059 E-30 w/15.3kW	
2	HEATER; pages 60 and 61	247509	247509	247509	2
3	MODULE, proportioner; page 58	245957	245957	245957	1
6	CONTROL, motor; page 65	24G881	24G881	24G881	1
8	TRANSFORMER;	247812	247812	247812	1
9	SHIELD	276879	276879	276879	1
14	TUBE, heater, component A	247915	247915	247915	1
15	TUBE, pump, component A	247914	247914	247914	1
16	TUBE, heater, component B	247917	247917	247917	1
17	TUBE, pump, component B	247916	247916	247916	1
21	CONNECTOR, tube	121311	121311	121311	2
28	MODULE, breaker; page 67	F	D	E	1
36	SWITCH, added pole; 380V			123968	1
39	FILTER; 230V	117667	117667	117667	1
51▲	LABEL, warning	198278	198278	198278	1
52	CABLE, harness, filter	15B385	15B385	15B385	1
65	KIT, fluid inlet	234367	234367	234367	1
65a	ELBOW, swivel; 3/4 npt(m) x 1" npt(f)	118463	118463	118463	2
71	SCREW, machine	---	---	---	2
72◆	BRACKET, heater	247523	247523	247523	4
73	WASHER, lock	103181	103181	103181	2
76	CAPACITOR	244733	244733	244733	1
77	BRACKET	197999	197999	197999	1
95◆	BOLT; hex hd; 3/8-16	100469	100469	100469	4
96◆	LOCKWASHER; 3/8				
	LOCKWASHER; 3/8	100133	100133	100133	4

Ref.	Description	Reactor Models			Qty
		259057 E-30 w/15.3kW	259058 E-30 w/15.3kW	259059 E-30 w/15.3kW	
97◆	NUT, channel				
	NUT, channel	118446	118446	118446	4
102	STRAP, motor	15B108	15B108	15B108	1
121	LABEL	15M499	15M499	15M499	1
122	Insulator	167002	167002	167002	4

▲ Replacement Danger and Warning labels, tags, and cards are available at no cost.

◆ Not required for slotted U-Channel style heater support rails.

--- Not for sale.

Sub Assemblies

Proportioner Module

245956 Module for E-20 and EXP-1

245957 Module for E-30

245959 Module for EXP-2

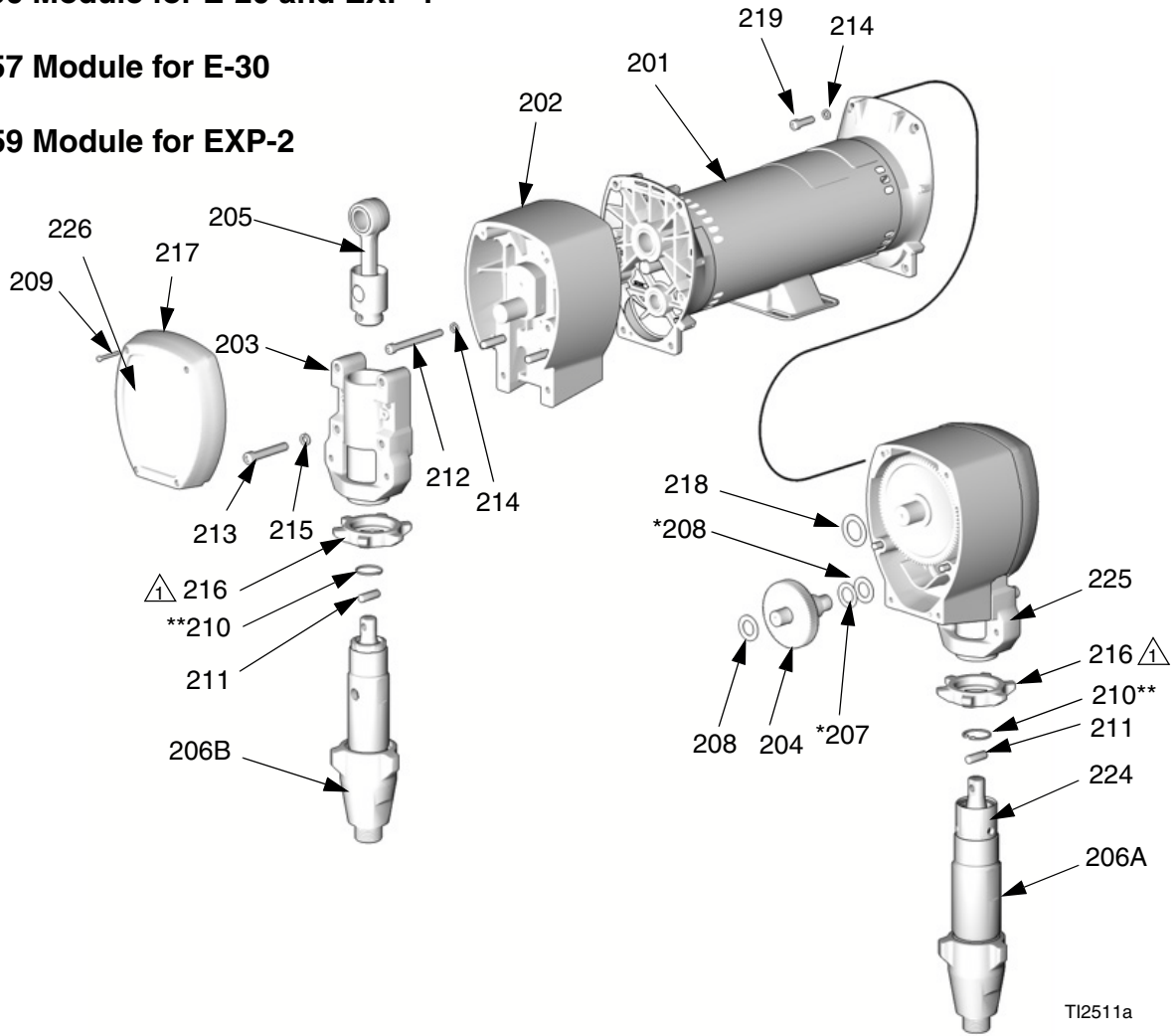

Flat side faces up.

Detail of Cycle Counter Switch

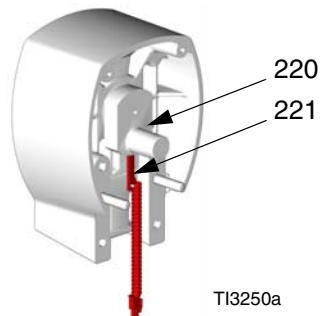

Proportioner Assembly

245956 Module, for E-20 and E-XP1

245957 Module, for E-30

245959 Module, for E-XP2

Ref.	Part	Description	Qty
201	245965	MOTOR; 245956	1
	245966	MOTOR; 245957, 245959	1
202	245968	HOUSING, drive; 245956	2
	245969	HOUSING, drive; 245957, 245959	2
203	240523	HOUSING, bearing; 245956	2
	241015	HOUSING, bearing; 245959	2
	245927	HOUSING, bearing; 245957	2
204	244264	GEAR; includes items 207, 208; 245956	2
	244265	GEAR; includes items 207, 208; 245957, 245959	2
205	241008	ROD, connecting; includes item 210; 245956	2
	241279	ROD, connecting; includes item 210; 245957, 245959	2
206A	246830	PUMP, displacement, component A; 245956; see 309577	1
	246831	PUMP, displacement, component A; 245959; see 309577	1
	246832	PUMP, displacement, component A; 245957; see 309577	1
206B	245970	PUMP, displacement, component B; 245956; see 309577	1
	245971	PUMP, displacement, component B; 245959; see 309577	1
	245972	PUMP, displacement, component B; 245957; see 309577	1
207*	114699	WASHER, thrust; steel	2
208*	114672	WASHER, thrust; bronze	4
209	114418	SCREW, self-tapping; 8-32 x 1 in. (25 mm); 245956	8
	114818	SCREW, self-tapping; 8-32 x 1-1/4 in. (31 mm); 245957, 245959	8
210**	176817	CLIP, wire; 245956	2
	183169	CLIP, wire; 245957, 245959	2
211	176818	PIN; 245956	2
	183210	PIN; 245957, 245959	2
212	107218	SCREW, cap, socket-hd; 1/4-20 x 2-3/4 in. (70 mm); 245956	4
	114686	SCREW, cap, socket-hd; 5/16-18 x 3-1/4 in. (83 mm); 245957, 245959	4
213	107210	SCREW, cap, socket-hd; 3/8-16 x 1-1/2 in. (38 mm); 245956	8
	114666	SCREW, cap, socket-hd; 3/8-16 x 2-1/4 in. (57 mm); 245957, 245959	8
214	105510	WASHER, lock; 1/4; 245956	12
	104008	WASHER, lock; 5/16; 245957, 245959	12
215	106115	WASHER, lock; 3/8 size	8
216	192723	NUT, retaining; 245956	2
	193031	NUT, retaining; 245959	2
	193394	NUT, retaining; 245957	2
217	179899	COVER; 245956	2
	241308	COVER; 245957, 245959	2
218	116191	WASHER, thrust; 245956	2
	116192	WASHER, thrust; 245957, 245959	2
219	100644	SCREW, cap, socket-hd; 1/4-20 x 3/4 in. (19 mm); 245956	4
	101864	SCREW, cap, socket-hd; 5/16-18 x 1 in. (25 mm); 245957, 245959	4
220	116618	MAGNET	1

Ref.	Part	Description	Qty
221	117770	SWITCH, cycle counter	1
223	100643	SCREW, cap, socket-hd; 1/4-20 x 1 in. (25 mm); 245956	4
	102962	SCREW, cap, socket-hd; 5/16-18 x 1-1/4 in. (31 mm); 245957, 245959	4
224	104765	PLUG	2
225	15C587	GUARD, finger; 245956	1
	15C588	GUARD, finger; 245959	1
226	15M507	LABEL; 245956	1
	15M508	LABEL; 245957, 245959	1

* Parts included in Gear Kit 244264 (245956) or 244265 (245957, 245959).

** Parts included in Connecting Rod Kit 241008 (245956) or 241279 (245957, 245959).

10.2 kW and 6.0 kW Fluid Heaters

Parts 247506 and 247507

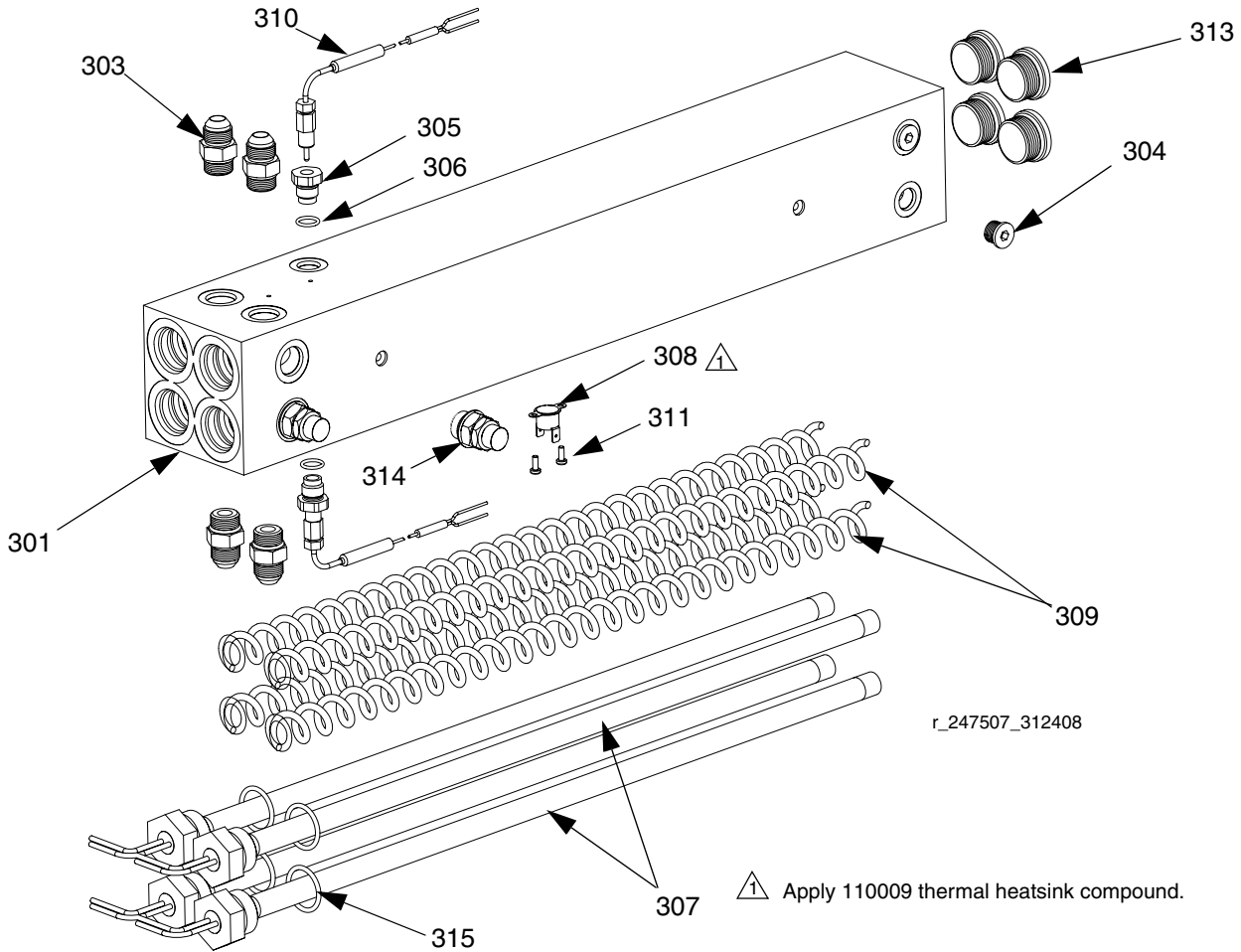

Ref	Part	Description	Qty.	Ref	Part	Description	Qty.
				310	117484	SENSOR	2
301		HOUSING, heater	1	311	100518	SCREW, machine, pan hd	2
303	121309	ADAPTER	4	313	15H305	PLUG, hollow	4
304	15H304	PLUG	2	314	247520	DISC, rupture	2
305	15H306	ADAPTER, thermocouple	2	315	124132	O-RINGS	4
306	120336	O-RING; fluoroelastomer	2				
307		HEATER, immersion	4				
	16A110	2550W; 10.4 kW heater only					
	16A112	1500 W; 6.0 kW heater only					
308	15B137	SWITCH, overtemperature	1				
309	15B135	MIXER, immersion heater	4				

7.65 kW Single Zone Fluid Heater

(Two Per Machine)

Part 247509

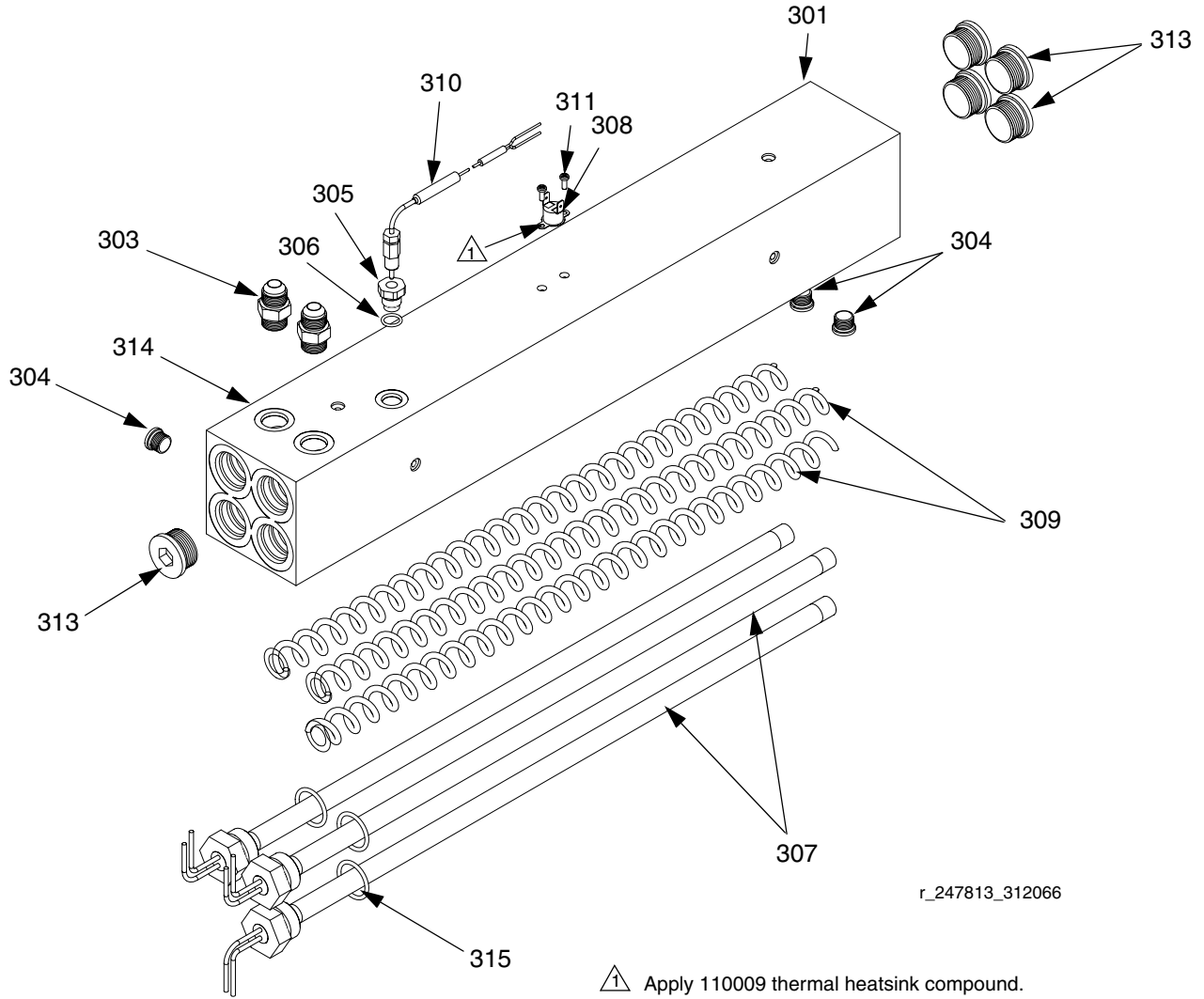

r_247813_312066

⚠ Apply 110009 thermal heatsink compound.

Ref.	Part	Description	Qty	Ref.	Part	Description	Qty
301		HOUSING, heater	1	310	117484	SENSOR	1
303	121309	ADAPTER	2	311	100518	SCREW, machine, pan hd	2
304	15H304	PLUG	3	313	15H305	PLUG, hollow	5
305	15H306	ADAPTER, thermocouple	1	314	247520	DISC, rupture; not shown	1
306	120336	O-RING; fluoroelastomer	1	315	124132	O-RING	3
307	16A110	HEATER, immersion; 2550 W	3				
308	15B137	SWITCH, overtemperature	1				
309	15B135	MIXER, immersion heater	3				

Reactor Frame

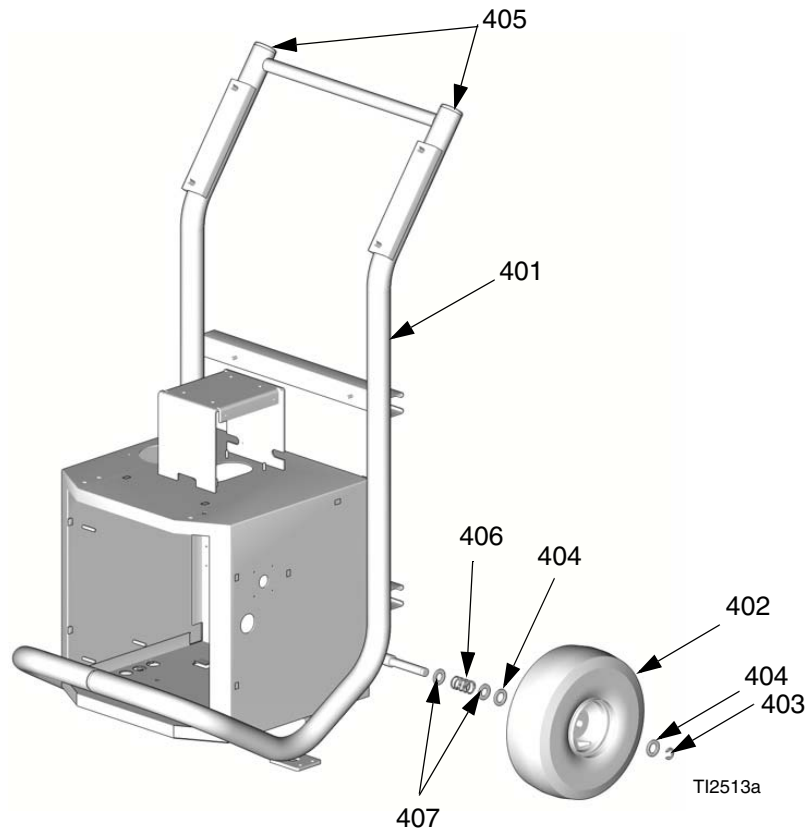

Ref.	Part	Description	Qty
401		FRAME	1
402	116478	WHEEL	2
403	101242	RING, retaining	2
404	116477	WASHER, flat; nylon	4
405	112125	PLUG	2
406	116411	SPRING	2
407	154636	WASHER, flat	4

Display

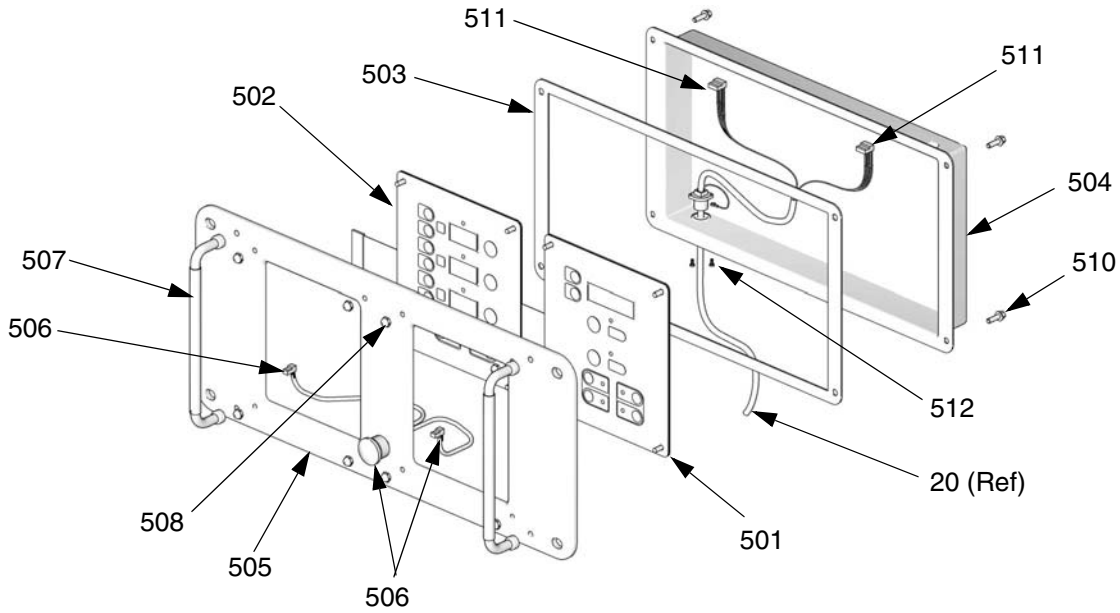

ti2574a

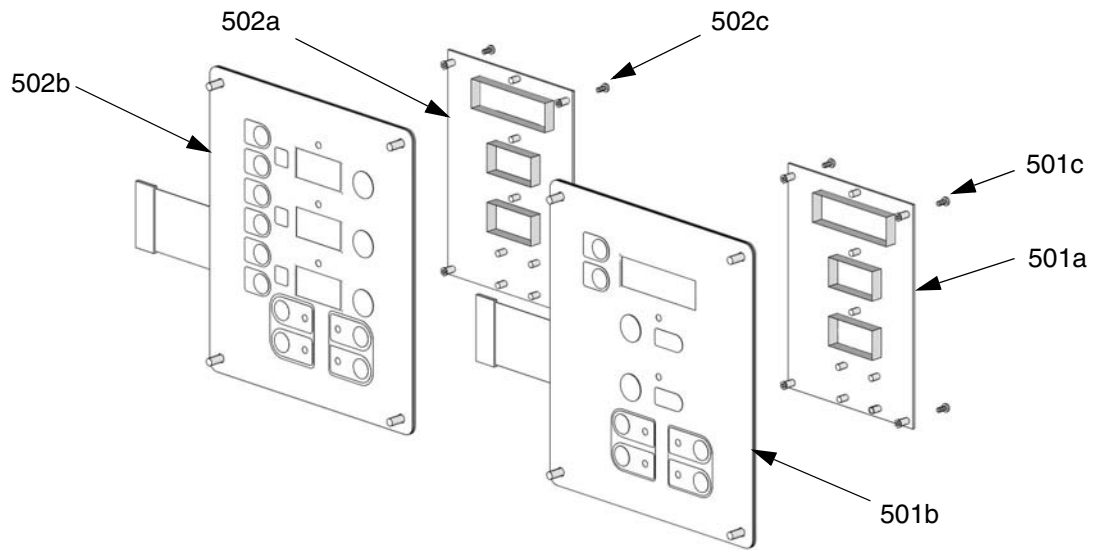

ti3172a

Ref.	Part	Description	Qty.	Ref.	Part	Description	Qty.
501	24G884	DISPLAY, pressure; includes 501a-501c	1	505	15B291	PLATE	1
501a	24G882	.BOARD, circuit	1	506	246287	HARNESS, wire, red stop button	1
501b	246478	.SWITCH, membrane	1	507	117499	HANDLE	2
501c	112324	.SCREW	4	508	117523	NUT, cap; 10-24	8
502	24G883	DISPLAY, temperature; includes 502a-502c	1	510	---	SCREW, machine, pan-hd; M5 x 0.8; 16 mm	4
502a	24G882	.BOARD, circuit	1	511	15B386	CABLE, display	1
502b	246479	.SWITCH, membrane	1	512	195853	SCREW, machine; M2.5 x 6	2
502c	112324	.SCREW	4	---			Not for sale.
503	15B293	GASKET	1				
504	15B292	COVER	1				

Temperature Control

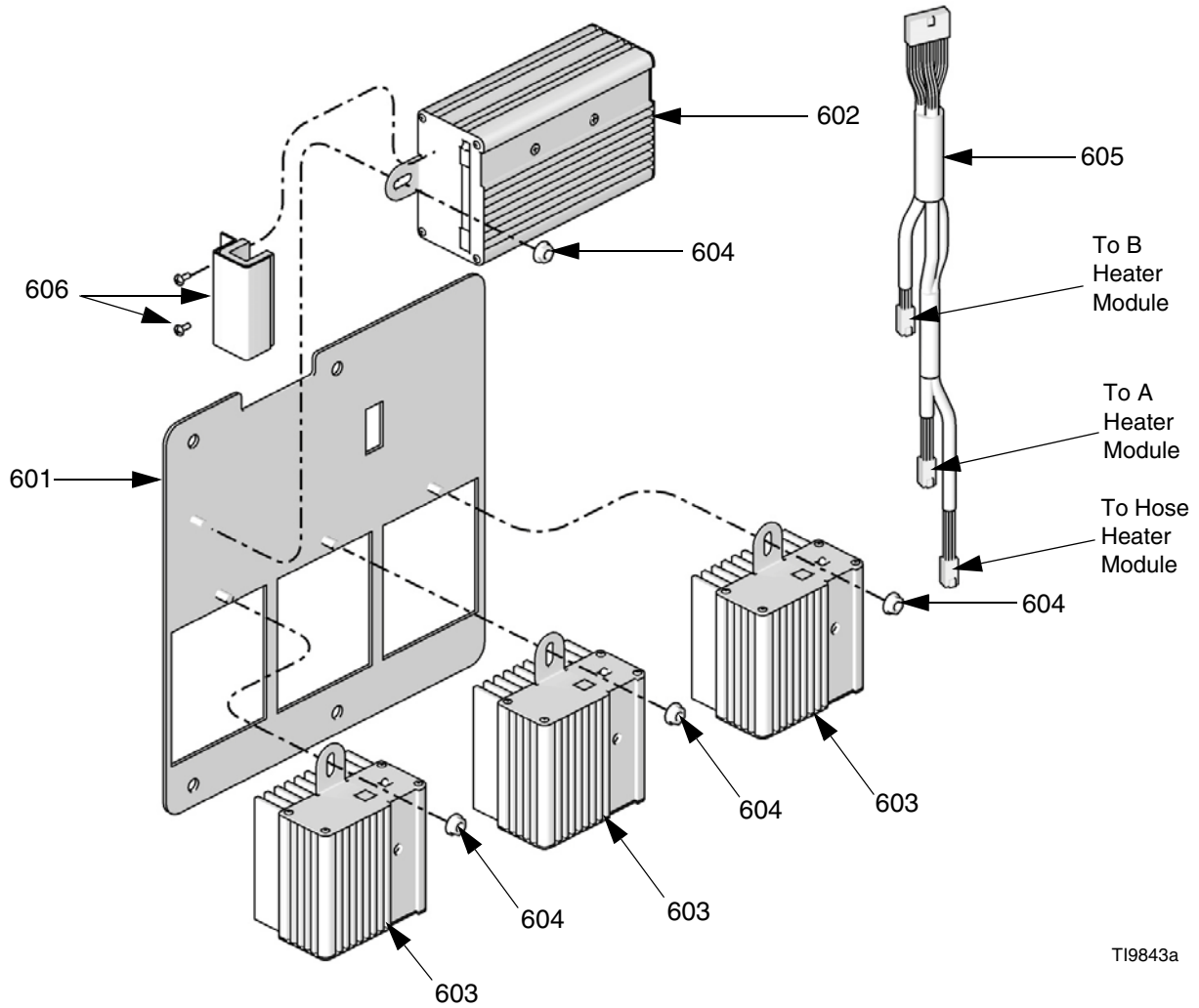

T19843a

Ref.	Part	Description	Qty.
601	247772	PANEL, module mounting	1
602	247827	HOUSING, control module	1
603	247828	HOUSING, heater module	3
604	115942	NUT, hex	4
605	247801	CABLE, communication	1
606	247825	KIT, cover, connector with screws	1

Motor Control

24G879 Motor Control for E-20 and EXP-1

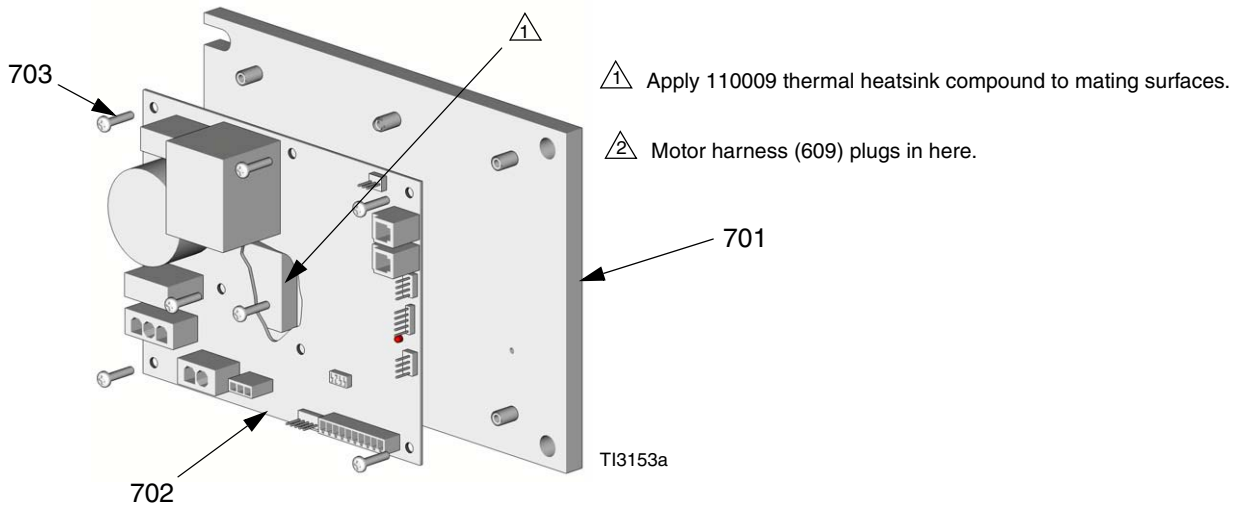

24G881 Motor Control for E-30 and EXP-2

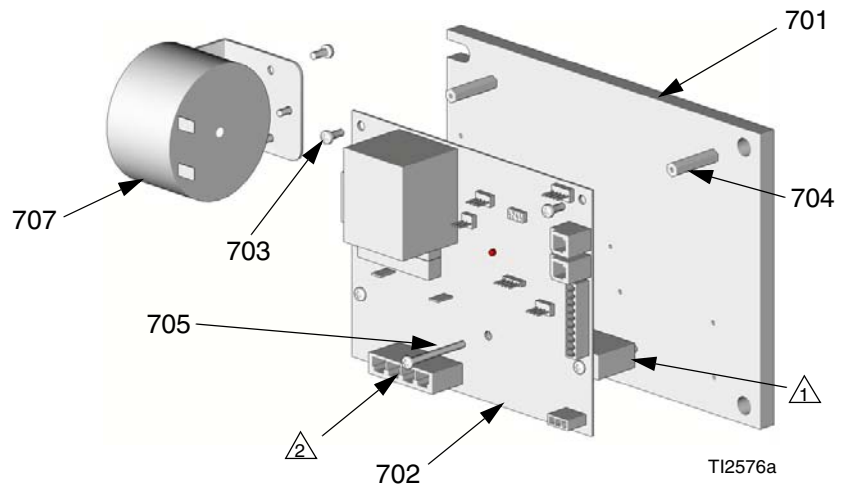

24G879 Motor Control for E-20 and EXP-1

Ref.	Part	Description	Qty.
701	15B297	HEAT SINK	1
702	24G878	BOARD, motor control	1
703	107156	SCREW, machine; 6-32	7

24G881 Motor Control for E-30 and EXP-2

Ref.	Part	Description	Qty.
701	16F745	HEAT SINK	1
702	---	BOARD, motor control	1
703	---	SCREW, machine; 6-32 x 3/8 in. (10 mm)	6
704	117526	SPACER	3
705	117683	SCREW, 6-32 x 1-1/2 in. (38 mm)	2
707	15C007	INDUCTOR	1
709	15B408	CABLE, harness, motor	1

--- Not for sale.

Fluid Manifold

- ① Torque to 355-395 in-lb (40.1-44.6 N•m).
- ② Apply sealant (113500) to threads.
- ③ Valve must be closed with handle position as shown on drawing.

** Apply PTFE tape or thread sealant to tapered threads.

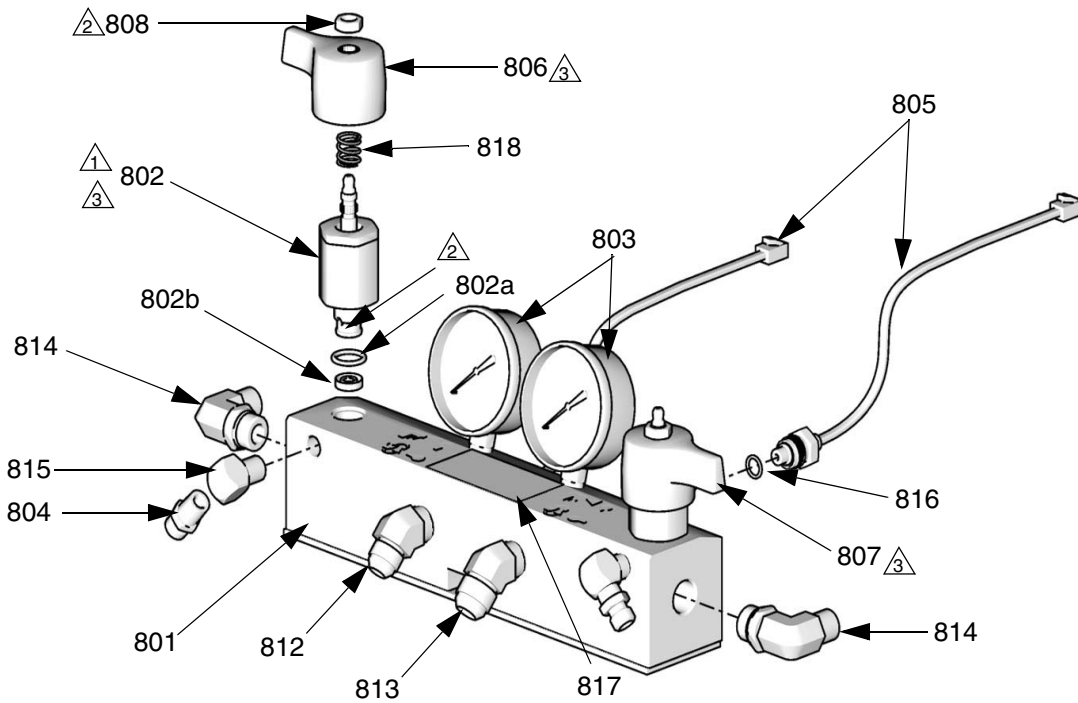

TI10959a

Ref.	Part	Description	Qty.	Ref.	Part	Description	Qty.
801	247837	MANIFOLD, fluid	1	814	121312	ELBOW, 90 degrees	2
802†	247824	VALVE, drain cartridge	2	815	100840	ELBOW, street; 1/4 npsm x 1/4 npt	2
802a†	158674	. O-RING	1	816	111457	O-RING, PTFE	2
802b†	247779	. SEAL, seat, valve	1	817▲	189285	LABEL, caution	1
803	102814	GAUGE, pressure, fluid	2	818†	150829	SPRING, compression	2
804	162453	FITTING, 1/4 npsm x 1/4 npt	2	▲ Replacement Warning labels, signs, tags, and cards are available at no cost.			
805	24K999	TRANSDUCER, pressure, control	2	† Included in the following complete valve kits*: ISO Valve Kit (left/red handle) 255149. Resin Valve Kit (right/blue handle) 255150. Valve Set Kit (both handles and grease gun) 255148.			
806	247788	HANDLE, red	1	* Complete valve kits also include thread sealant. (Purchase kits separately).			
807	247789	HANDLE, blue	1				
808†	112309	NUT, hex, jam	2				
812	117556	NIPPLE, #8 JIC x 1/2 npt	1				
813	117557	NIPPLE, #10 JIC x 1/2 npt	1				

Circuit Breaker Modules

A - 230V, 3 Phase Circuit Breaker Modules (E-20, EXP-1)

 For wiring and cable connections, refer to electrical diagrams manual 312067, supplied. See page 70 for parts.

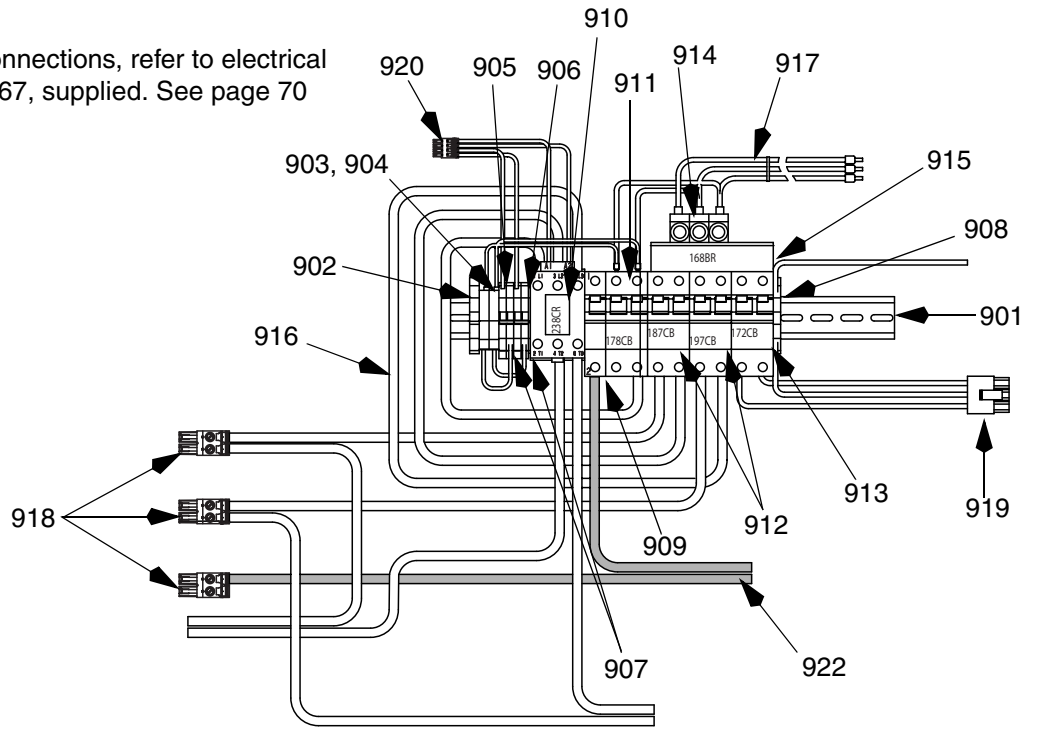

B - 400V, 3 Phase Circuit Breaker Modules (E-20, E-XP1)

 For wiring and cable connections, refer to electrical diagrams manual 312067, supplied. See page 70 for parts.

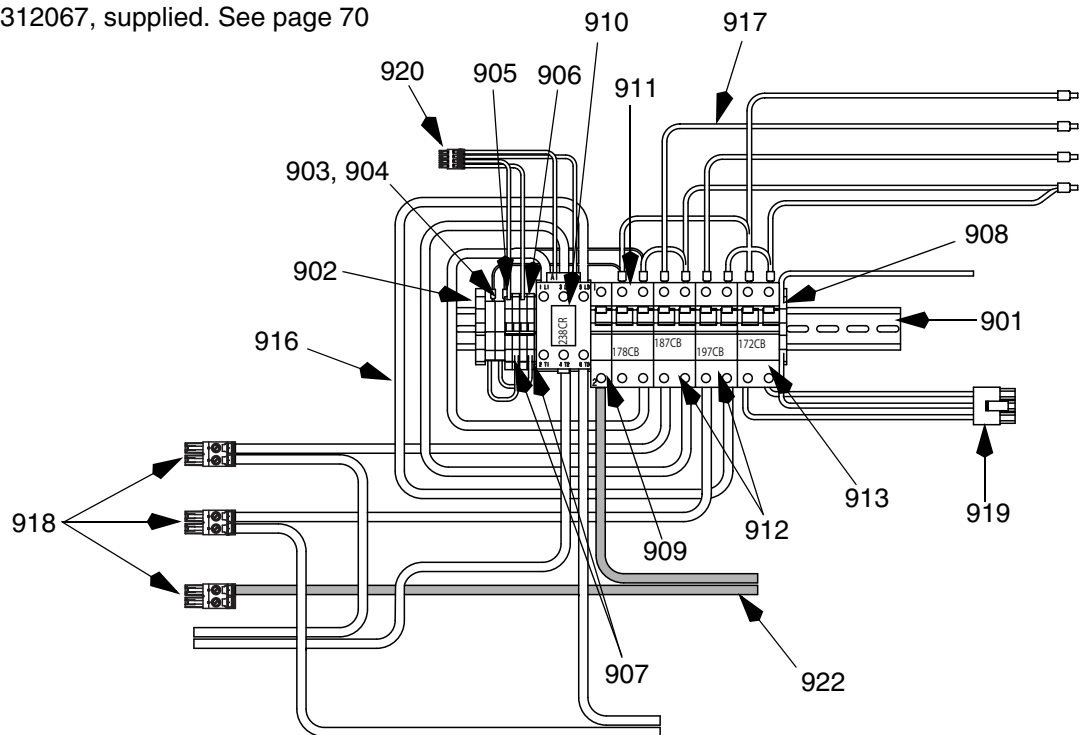

C - 230V, 1 Phase Circuit Breaker Modules (E-20, EXP-1)

 For wiring and cable connections, refer to electrical diagrams manual 312067, supplied. See page 70 for parts.

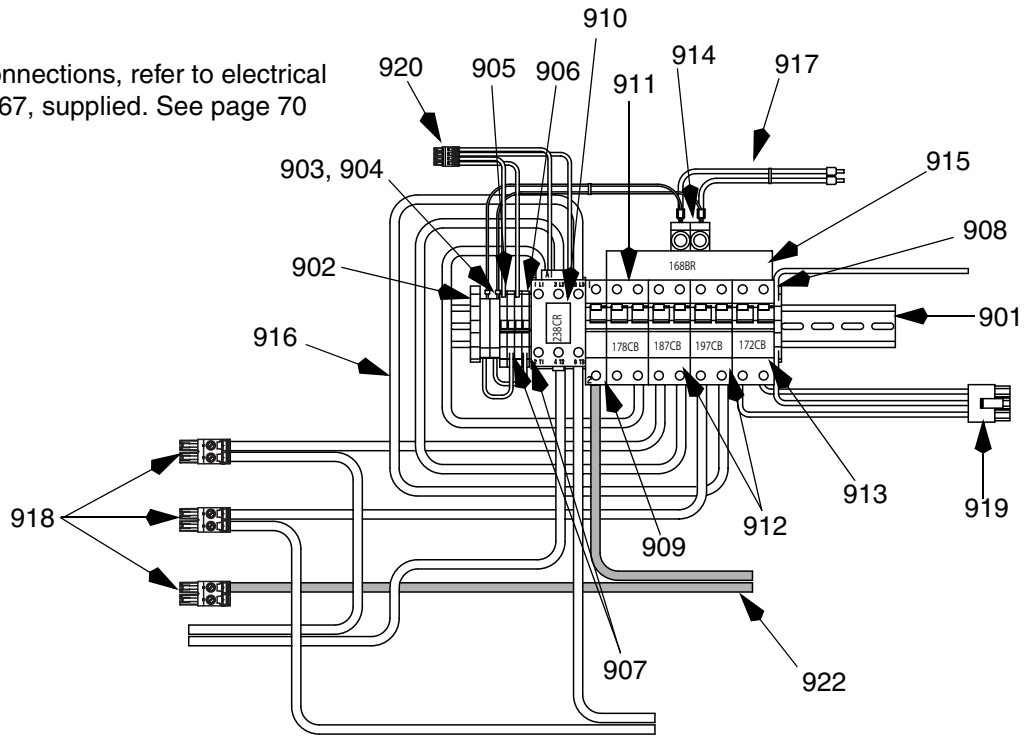

D - 230V, 3 Phase Circuit Breaker Modules (E-30, EXP-2)

 For wiring and cable connections, refer to electrical diagrams manual 312067, supplied. See page 70 for parts.

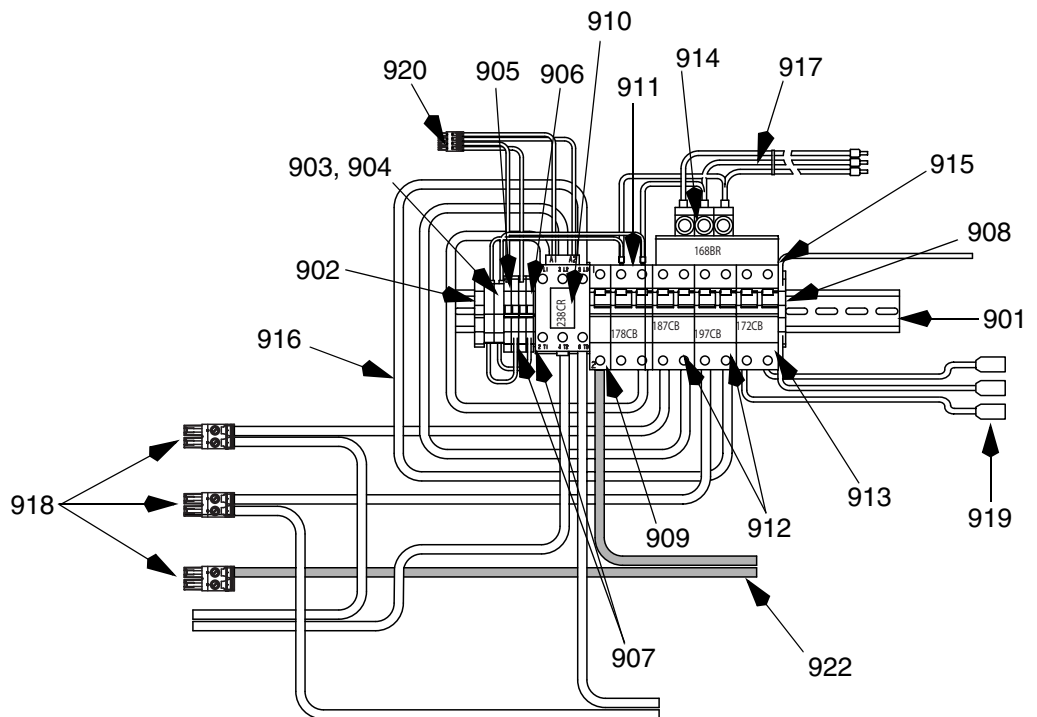

E - 400V, 3 Phase Circuit Breaker Modules (E-30, E-XP2)

For wiring and cable connections, refer to electrical diagrams manual 312067, supplied. See page 70 for parts.

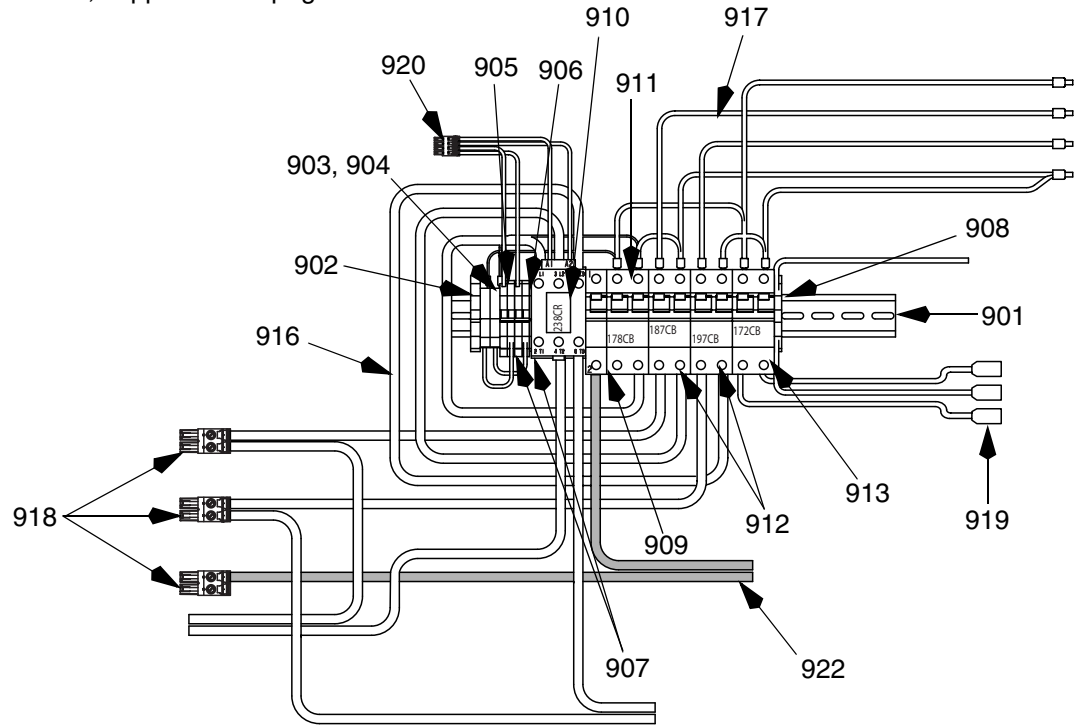

F - 230V, 1 Phase Circuit Breaker Modules (E-30, EXP-2)

For wiring and cable connections, refer to electrical diagrams manual 312067, supplied. See page 70 for parts.

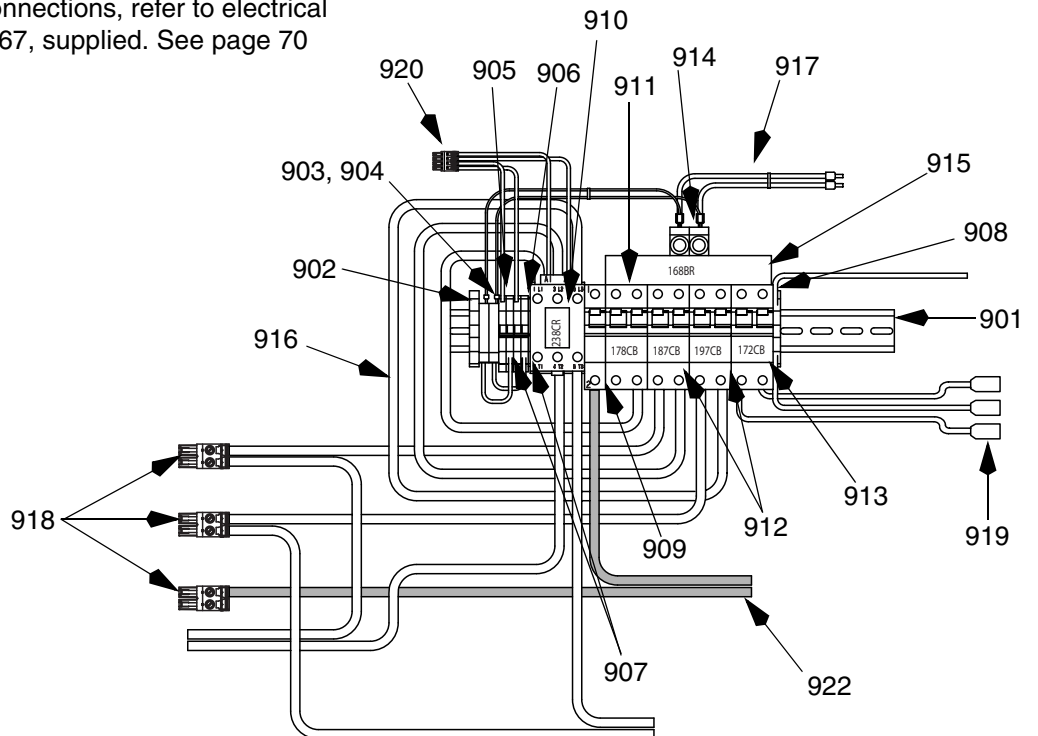

Circuit Breaker Modules Parts List

Ref.	Description	Breaker Modules						Qty
		E-20 and EXP-1 Models			E-30 and EXP-2 Models			
		A 230V, 3 phase	B 400V, 3 phase	C 230V, 1 phase	D 230V, 3 phase	E 400V, 3 phase	F 230V, 1 phase	
901	RAIL, mounting	255028	255028	255028	255028	255028	255028	1
902	CLAMP, block, end	255045	255045	255045	255045	255045	255045	1
903	HOLDER, fuse terminal, block	255043	255043	255043	255043	255043	255043	2
904	FUSE	255023	255023	255023	255023	255023	255023	2
905	TERMINAL, block	255042	255042	255042	255042	255042	255042	4
906	TERMINAL, end cover	---	---	---	---	---	---	1
907	BRIDGE, plug in, jumper	255044	255044	255044	255044	255044	255044	2
908	BLOCK, terminal ground	255046	255046	255046	255046	255046	255046	1
909	BREAKER, 1 pole, 50A	255026	255026	255026	255026	255026	255026	1
910	CONTACTOR, relay, 65A	255022	255022	255022	255022	255022	255022	1
911	BREAKER, 2 phase, 40A	247768	247768	247768	247768	247768	247768	1
912	BREAKER, 2 phase, 25A	255050	255050	255050	255050	255050	255050	2
	BREAKER, 2 phase, 40A	247768	247768	247768	247768	247768	247768	2
913	BREAKER, 2 phase, 20A	255049	255049	255049	255049	255049	255049	1
914	CONNECTOR, power lug	117679			117679			3
	CONNECTOR, power lug			117679			117679	2
915	BAR, power buss, 3 phase	117805			117805			1
	BAR, power buss, 1 phase			117678			117678	1
916	CABLE, harness lower	247802	247802	247802	247802	247802	247802	1
917	CABLE, harness upper	247805	247806	247804	247805	247806	247804	1
918	CONNECTOR, 2 pin large	255027	255027	255027	255027	255027	255027	3
919	CONNECTOR, 3 pin	247522	247522	247522	247567	247567	247567	1
920	CONNECTOR, 4 pin	255031	255031	255031	255031	255031	255031	1
922	CABLE, harness	247791	247791	247791	247791	247791	247791	1

--- Not for sale.

248669 Conversion Kit

Convert and phase E-XP2 to and E-30 with 15.3 kW of heat by changing displacement pumps, bearings, and changing the Motor Control DIP settings to that of an E-30. For removal and installation of displacement pumps and bearings, see **Pump Removal** (page 24) and **Pump Installation** (page 26). For changing Motor Control DIP settings, see **Motor Control Board**, page 34.

Ref.	Part	Description	Qty.
65	118463	ELBOW, swivel; 3/4 npt(m) x 1 in. npt(f)	2
303	245927	HOUSING, bearing	2
306A	246832	PUMP, displacement, component A; see 309557	1
306B	245972	PUMP, displacement, component B; see 309577	1
316	193394	NUT, retaining	2

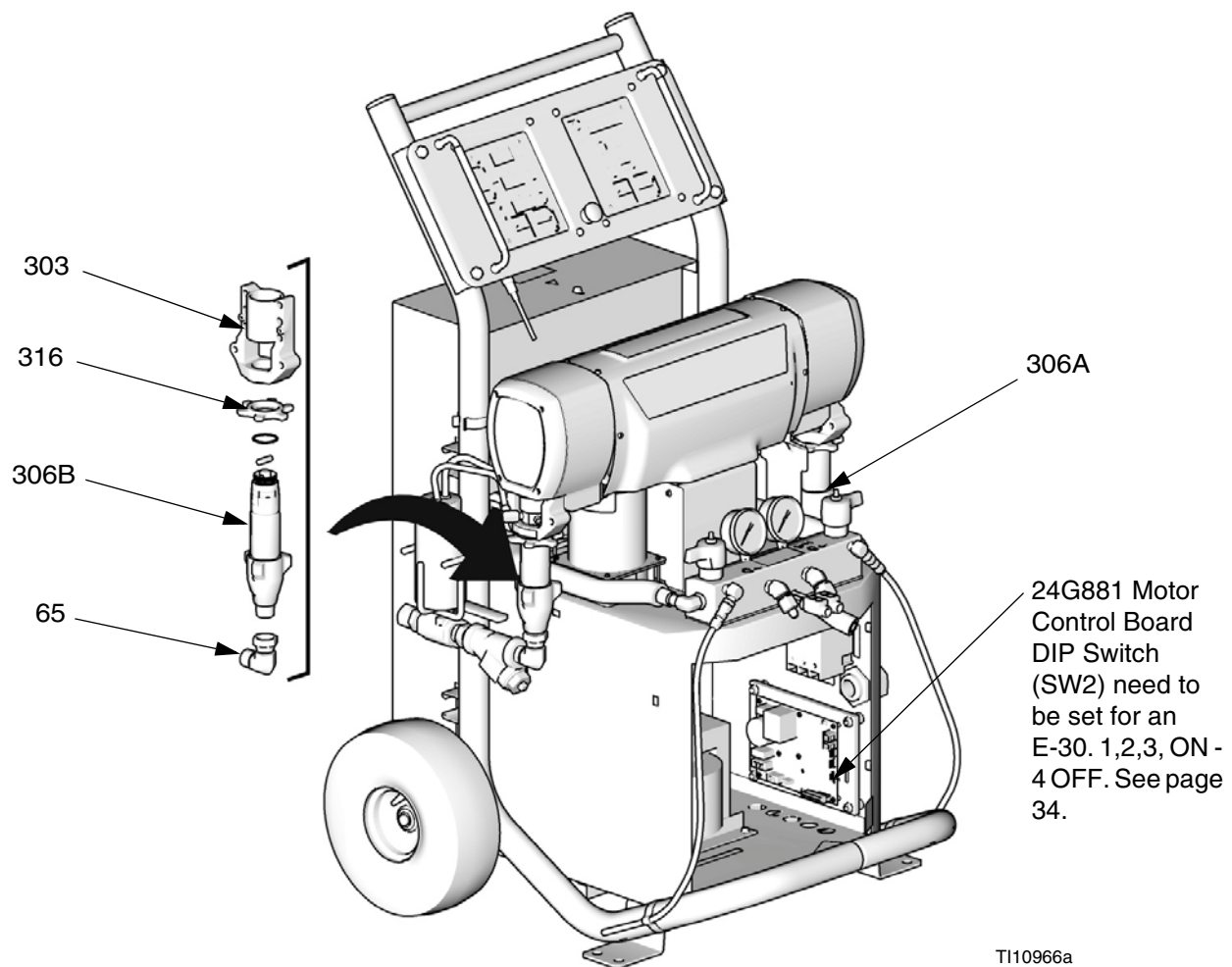

Dimensions

Dimension	in. (mm)
A	46.0 (1168)
B	31.0 (787)
C	33.0 (838)

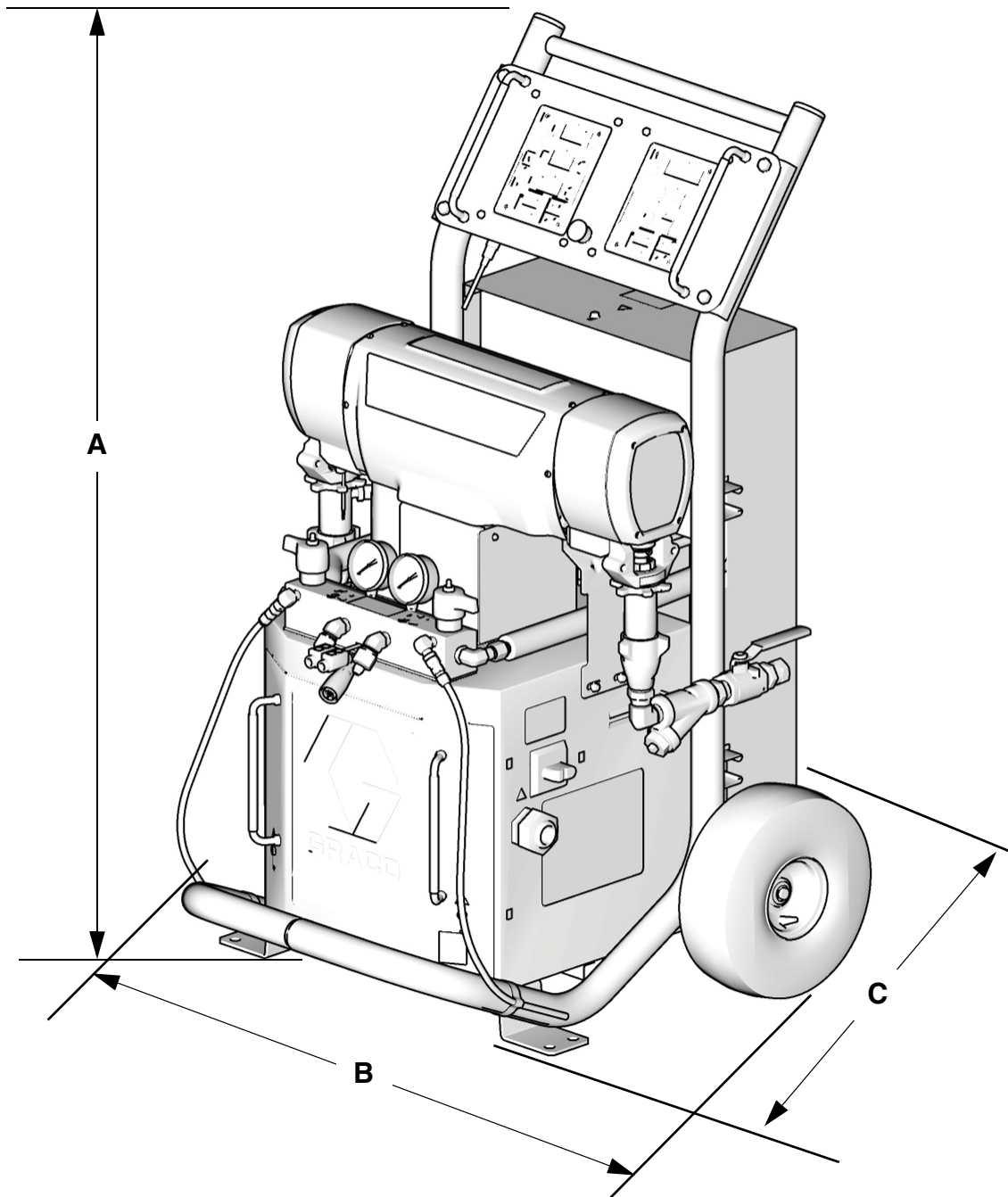

T110953a

Technical Data

Category	Data
Maximum Fluid Working Pressure	Models E-20 and E-30: 2000 psi (14 MPa, 140 bar) Model E-XP1: 2500 psi (17.2 MPa, 172 bar) Model E-XP2: 3500 psi (24.1 MPa, 241 bar)
Maximum Fluid Temperature	190°F (88°C)
Maximum Output	Model E-20: 20 lb/min (9 kg/min) Model E-30: 30 lb/min (13.5 kg/min) Model E-XP1: 1 gpm (3.8 liter/min) Model E-XP2: 2 gpm (7.6 liter/min)
Output per Cycle (A and B)	Model E-20 and E-XP1: 0.0104 gal. (0.0395 liter) Model E-30: 0.0272 gal. (0.1034 liter) Model E-XP2: 0.0203 gal. (.0771 liter)
Line Voltage Requirement	Parts 259024, 259025, 259026, 259028, 259057: 195-264 Vac, 50/60 Hz Parts 259029, 259030, 259031, 259032, 259059: 338-457 Vac, 50/60 Hz Parts 259033, 259034, 259035, 259036, 259058: 195-264 Vac, 50/60 Hz
Amperage Requirement	See Table 1, page 9.
Heater Power	Model E-20: 6000 Watts Model E-30 and E-XP1: 10200 Watts Models E-XP2 and E-30 with 15.3kW of heat: 15300 Watts
Sound Power, per ISO 9614-2	Model E-20: 80 dB(A) at 2000 psi (14 MPa, 140 bar), 0.5 gpm (1.9 lpm) Model E-30: 93.5 dB(A) at 1000 psi (7 MPa, 70 bar), 3.0 gpm (11.4 lpm) Model E-XP1: 80 dB(A) at 2000 psi (14 MPa, 140 bar), 0.5 gpm (1.9 lpm) Model E-XP2: 83.5 dB(A) at 3000 psi (21 MPa, 210 bar), 1.0 gpm (3.8 lpm)
Sound Pressure, 1 m from equipment	Model E-20: 70.2 dB(A) at 2000 psi (14 MPa, 140 bar), 0.5 gpm (1.9 lpm) Model E-30: 83.6 dB(A) at 1000 psi (7 MPa, 70 bar), 3.0 gpm (11.4 lpm) Model E-XP1: 70.2 dB(A) at 2000 psi (14 MPa, 140 bar), 0.5 gpm (1.9 lpm) Model E-XP2: 73.6 dB(A) at 3000 psi (21 MPa, 210 bar), 1.0 gpm (3.8 lpm)
Fluid Inlets	3/4 npt(f), with 3/4 npsm(f) union
Fluid Outlets	Component A (ISO): -8 (1/2 in.) JIC, with -5 (5/16 in.) JIC adapter Component B (RES): -10 (5/8 in.) JIC, with -6 (3/8 in.) JIC adapter
Fluid Circulation Ports	1/4 npsm(m), with plastic tubing; 250 psi (1.75 MPa, 17.5 bar) maximum
Weight	Model E-20 and E-XP1: 342 lb (155 kg) Model E-30: 400 lb (181kg) Models E-XP2 and E-30 with 15.3kW of heat: 438 lb (198 kg)
Wetted Parts	Aluminum, stainless steel, zinc plated, carbon steel, brass, carbide, chrome, chemically resistant o-rings, PTFE, ultra-high molecular weight polyethylene

All other brand names or marks are used for identification purposes and are trademarks of their respective owners.

Graco Standard Warranty

Graco warrants all equipment referenced in this document which is manufactured by Graco and bearing its name to be free from defects in material and workmanship on the date of sale to the original purchaser for use. With the exception of any special, extended, or limited warranty published by Graco, Graco will, for a period of twelve months from the date of sale, repair or replace any part of the equipment determined by Graco to be defective. This warranty applies only when the equipment is installed, operated and maintained in accordance with Graco's written recommendations.

This warranty does not cover, and Graco shall not be liable for general wear and tear, or any malfunction, damage or wear caused by faulty installation, misapplication, abrasion, corrosion, inadequate or improper maintenance, negligence, accident, tampering, or substitution of non-Graco component parts. Nor shall Graco be liable for malfunction, damage or wear caused by the incompatibility of Graco equipment with structures, accessories, equipment or materials not supplied by Graco, or the improper design, manufacture, installation, operation or maintenance of structures, accessories, equipment or materials not supplied by Graco.

This warranty is conditioned upon the prepaid return of the equipment claimed to be defective to an authorized Graco distributor for verification of the claimed defect. If the claimed defect is verified, Graco will repair or replace free of charge any defective parts. The equipment will be returned to the original purchaser transportation prepaid. If inspection of the equipment does not disclose any defect in material or workmanship, repairs will be made at a reasonable charge, which charges may include the costs of parts, labor, and transportation.

THIS WARRANTY IS EXCLUSIVE, AND IS IN LIEU OF ANY OTHER WARRANTIES, EXPRESS OR IMPLIED, INCLUDING BUT NOT LIMITED TO WARRANTY OF MERCHANTABILITY OR WARRANTY OF FITNESS FOR A PARTICULAR PURPOSE.

Graco's sole obligation and buyer's sole remedy for any breach of warranty shall be as set forth above. The buyer agrees that no other remedy (including, but not limited to, incidental or consequential damages for lost profits, lost sales, injury to person or property, or any other incidental or consequential loss) shall be available. Any action for breach of warranty must be brought within two (2) years of the date of sale.

GRACO MAKES NO WARRANTY, AND DISCLAIMS ALL IMPLIED WARRANTIES OF MERCHANTABILITY AND FITNESS FOR A PARTICULAR PURPOSE, IN CONNECTION WITH ACCESSORIES, EQUIPMENT, MATERIALS OR COMPONENTS SOLD BUT NOT MANUFACTURED BY GRACO. These items sold, but not manufactured by Graco (such as electric motors, switches, hose, etc.), are subject to the warranty, if any, of their manufacturer. Graco will provide purchaser with reasonable assistance in making any claim for breach of these warranties.

In no event will Graco be liable for indirect, incidental, special or consequential damages resulting from Graco supplying equipment hereunder, or the furnishing, performance, or use of any products or other goods sold hereto, whether due to a breach of contract, breach of warranty, the negligence of Graco, or otherwise.

FOR GRACO CANADA CUSTOMERS

The Parties acknowledge that they have required that the present document, as well as all documents, notices and legal proceedings entered into, given or instituted pursuant hereto or relating directly or indirectly hereto, be drawn up in English. Les parties reconnaissent avoir convenu que la rédaction du présente document sera en Anglais, ainsi que tous documents, avis et procédures judiciaires exécutés, donnés ou intentés, à la suite de ou en rapport, directement ou indirectement, avec les procédures concernées.

Graco Information

For the latest information about Graco products, visit www.graco.com.

TO PLACE AN ORDER, contact your Graco distributor or call to identify the nearest distributor.

Phone: 612-623-6921 **or Toll Free:** 1-800-328-0211, **Fax:** 612-378-3505

*All written and visual data contained in this document reflects the latest product information available at the time of publication.
Graco reserves the right to make changes at any time without notice.*

For patent information, see www.graco.com/patents.

Original instructions. This manual contains English. MM 312066

Graco Headquarters: Minneapolis

International Offices: Belgium, China, Japan, Korea

GRACO INC. AND SUBSIDIARIES • P.O. BOX 1441 • MINNEAPOLIS MN 55440-1441 • USA

Copyright 2007, Graco Inc. All Graco manufacturing locations are registered to ISO 9001.

www.graco.com

Revised November 2013