

# Power-Lock™ Heated Hose

309572S

***For use with plural component proportioners. Not for use in explosive atmospheres.***

*See page 3 for Maximum Fluid Working Pressure*

*130 psi (0.9 MPa, 9 bar) Maximum Air Working Pressure*

*180°F (82°C) Maximum Hose Operating Temperature*



**Important Safety instructions.**

Read all warnings and instructions in this manual.  
Save these instructions. See page 3 for a list of  
part numbers.

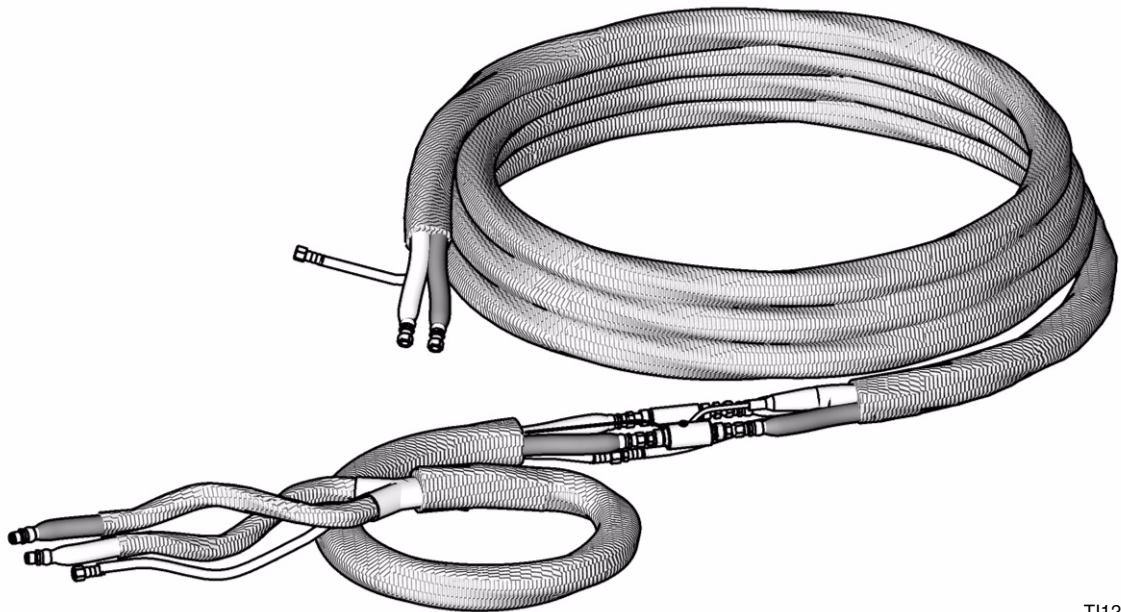

T112157a

# Contents

**Manual Conventions** ..... 2

**Power-Lock Hose Bundle Part Numbers** ..... 3

    Fluid Temperature Sensor (FTS) ..... 4

    Cross Reference Table ..... 4

**Warnings** ..... 6

**Installation** ..... 8

    Description ..... 8

    Set Transformer Wire Taps ..... 8

    Connect Whip Hose to Gun or Gun Manifold ... 9

    Connect Heated Hoses ..... 10

    Connect 261669 FTS and Heated Dual Whip  
    Hose ..... 13

    Connect 261670 FTS ..... 14

    Check Hoses for Leaks ..... 15

    Protective Covering ..... 16

**Operation** ..... 17

    Fluid Temperature Sensor (FTS) Calibration ... 17

**Maintenance** ..... 17

**Parts** ..... 18

    Using 261669 Fluid Temperature Sensor  
    (JIC to JIC fittings) ..... 18

    Using 261670 Fluid Temperature Sensor  
    (JIC to NPT fittings) ..... 19

    15F144 Hose Wire Jumper ..... 21

**Technical Data** ..... 23

**Accessories** ..... 23

    Scuff Guard ..... 23



**Warranty** ..... 24

**Graco Phone Numbers** ..... 24

# Manual Conventions

## Warning

 **WARNING**

A warning alerts you to possible serious injury or death if you do not follow instructions.

Symbols, such as fluid injection (shown), alert you to a specific hazard and direct you to read the indicated hazard warnings on pages 6-7.

## Caution

 **CAUTION**

A caution alerts you to possible equipment damage or destruction if you do not follow instructions.

## Note

 A note indicates additional helpful information.

# Power-Lock Hose Bundle Part Numbers

You need at least one 50 ft (15.2 m) main hose, one fluid temperature sensor (FTS), and one whip hose or one wire harness jumper (part no. 15C517) to make a complete heated hose assembly. See the tables below. Be sure the selected hose meets your maximum pressure and hose diameter requirements.

Each hose contains an A component hose, a B component hose, and an air hose (1/4 npt x 1/4 npsm, m x f). Common insulated hoses do not contain an air hose. These hoses are typically used for non 1:1 ratio materials.

Part No. (Series)	Description	ID in. (mm)	Length ft (m)	JIC Fittings		Maximum Fluid Pressure psi (MPa, bar)
				“A” inlet (f)/ outlet (m)	“B” inlet (f)/ outlet (m)	
<b>2 Component Main Hoses - Individual Insulation with Air Hose</b>						
246045 (F)	With FTS cable, no scuff guard	1/4 (6)	50 (15.2)	5/5	6/6	2000 (13.8, 138)
246046 (F)	With FTS cable, no scuff guard	3/8 (10)	50 (15.2)	5/5	6/6	2000 (13.8, 138)
246047 (F)	With FTS cable, no scuff guard	1/2 (13)	50 (15.2)	8/8	10/10	2000 (13.8, 138)
246048 (F)	With FTS cable, no scuff guard	1/4 (6)	25 (7.6)	5/5	6/6	2000 (13.8, 138)
249587 (F)	No FTS cable, no scuff guard	1/4 (6)	25 (7.6)	5/5	6/6	2000 (13.8, 138)
246049 (F)	With FTS cable, no scuff guard	3/8 (10)	25 (7.6)	5/5	6/6	2000 (13.8, 138)
246074 (F)	No FTS cable, no scuff guard	1/4 (6)	50 (15.2)	5/5	6/6	2000 (13.8, 138)
246075 (F)	No FTS cable, no scuff guard	3/8 (10)	50 (15.2)	5/5	6/6	2000 (13.8, 138)
246076 (F)	No FTS cable, no scuff guard	1/2 (13)	50 (15.2)	8/8	10/10	2000 (13.8, 138)
246678 (F)	With FTS cable and scuff guard	3/8 (10)	50 (15.2)	5/5	6/6	2000 (13.8, 138)
246052 (F)	With FTS cable, no scuff guard	1/4 (6)	50 (15.2)	5/5	6/6	3500 (24.1, 241)
246053 (F)	With FTS cable, no scuff guard	3/8 (10)	50 (15.2)	5/5	6/6	3500 (24.1, 241)
246054 (F)	With FTS cable, no scuff guard	1/2 (13)	50 (15.2)	8/8	10/10	3500 (24.1, 241)
246679 (F)	With FTS cable and scuff guard	3/8 (10)	50 (15.2)	5/5	6/6	3500 (24.1, 241)
<b>249588 (F)</b>	<b>No FTS cable, no scuff guard</b>	<b>3/8 (10)</b>	<b>50 (15.2)</b>	<b>5/5</b>	<b>6/6</b>	<b>3500 (24.1, 241)</b>
247164 (F)	With FTS cable and scuff guard	1/4 (6) A x 3/8 (10) B	50 (15.2)	5/5	6/6	3500 (24.1, 241)
256548 (A)	With FTS cable and scuff guard	1/2 (13)	50 (15.2)	5/5	6/6	3500 (24.1, 241)
256549 (A)	No FTS cable, and scuff guard	3/8 (10)	50 (15.2)	5/5	6/6	2000 (13.8, 138)
261328 (F)	No FTS cable, no scuff guard	3/8 (10)	25 (7.6)	5/5	6/6	2000 (13.8, 138)
261332 (F)	No FTS cable, no scuff guard	3/8 (10)	25 (7.6)	5/5	6/6	5000 (34.5, 345)
261335 (F)	No FTS cable, no scuff guard	1/2 (13)	50 (15.2)	8/8	10/10	3500 (24.1, 241)
261336 (F)	With FTS cable, no scuff guard	3/8 (10) A x 1/2 (13) B	50 (15.2)	5/5	10/10	3500 (24.1, 241)
<b>2 Component Whip Hoses - Individual Insulation with Air Hose</b>						
249586 (G)	Whip hose with scuff guard	1/4 (6)	3 (.9)	5/5	6/6	2000 (13.8, 138)
246050 (G)	Whip hose with scuff guard	1/4 (6)	10 (3)	5/5	6/6	2000 (13.8, 138)
246051 (G)	Whip hose with scuff guard	3/8 (10)	10 (3)	5/5	6/6	2000 (13.8, 138)
<b>246055 (G)</b>	<b>Whip hose with scuff guard</b>	<b>1/4 (6)</b>	<b>10 (3)</b>	<b>5/5</b>	<b>6/6</b>	<b>3500 (24.1, 241)</b>
246056 (G)	Whip hose with scuff guard	3/8 (10)	10 (3)	5/5	6/6	3500 (24.1, 241)
256407 (A)	Unheated hose with scuff guard	1/4 (6)	6 (1.8)	5/5	6/6	3500 (24.1, 241)
<b>2 Component Main Hoses - Common Insulation without Air Hose</b>						
248907 (F)	With FTS cable	1/4 (6) x 3/8 (10)	50 (15.2)			5000 (34.5, 345)
248908 (F)	With FTS cable	3/8 (10) x 3/8 (10)	50 (15.2)			5000 (34.5, 345)

## Fluid Temperature Sensor (FTS)

Part No. (Series)	Fittings	Description	Max. Fluid Pressure psi (MPa, bar)
261669 (A)	JIC to JIC (See pg. 18 for fitting detail)	Fluid Temperature Sensor (for heated standard systems)	5000 (34.5, 345)
261670 (A)	JIC to NPT (See pg. 19 for fitting detail)	Fluid Temperature Sensor (for heated mix manifold systems)	5000 (34.5, 345)

## Cross Reference Table

Max Fluid Pressure psi (MPa, bar)	Length ft (m)	ID in. (mm)	Description	Old Part	Replaced By	JIC Fittings	
						"A" inlet (f)/ outlet (m)	"B" inlet (f)/ outlet (m)
<b>2 Component Main Hoses - Individual Insulation with Air Hose</b>							
2000 (13.8, 138)	50 (15.2)	1/4 (6)	With FTS cable, no scuff guard	1225-TC-PL	246045	5/5	6/6
2000 (13.8, 138)	50 (15.2)	3/8 (10)	With FTS cable, no scuff guard	1200-TC-PL	246046	5/5	6/6
2000 (13.8, 138)	50 (15.2)	1/2 (13)	With FTS cable, no scuff guard	5225-50-TC-PL	246047	8/8	10/10
2000 (13.8, 138)	50 (15.2)	1/4 (6)	No FTS cable, no scuff guard	1225B-PL	246074	5/5	6/6
2000 (13.8, 138)	50 (15.2)	3/8 (10)	No FTS cable, no scuff guard	1200B-PL	246075	5/5	6/6
2000 (13.8, 138)	50 (15.2)	1/2 (13)	No FTS cable, no scuff guard	5225-50-PL	246076	8/8	10/10
2000 (13.8, 138)	25 (7.6)	1/4 (6)	No FTS cable, no scuff guard	1260A-PL	249587	5/5	6/6
3500 (24.1, 241)	50 (15.2)	1/4 (6)	With FTS cable, no scuff guard	14200-50-TC-PL	246052	5/5	6/6
3500 (24.1, 241)	50 (15.2)	3/8 (10)	With FTS cable, no scuff guard	14230-50-TC-PL	246053	5/5	6/6
3500 (24.1, 241)	50 (15.2)	1/2 (13)	With FTS cable, no scuff guard	14235-50-TC-PL	246054	8/8	10/10
3500 (24.1, 241)	50 (15.2)	3/8 (10)	No FTS cable, no scuff guard	14230-50-PL	249588	5/5	6/6
2000 (13.8, 138)	25 (7.6)	3/8 (10)	No FTS cable, no scuff guard	1200B-25-PL	261328	5/5	6/6
3500 (24.1, 241)	50 (15.2)	1/2 (13)	No FTS cable, no scuff guard	14235-50-PL	26135	8/8	10/10
3500 (24.1, 241)	50 (15.2)	3/8 (10) x 1/2 (13)	With FTS cable, no scuff guard	14276-50-TC-PL	261336	5/5	10/10
5000 (34.5, 345)	50 (15.2)	3/8 (10)	No FTS cable, no scuff guard	14230-25-PL	261332	5/5	6/6

Max Fluid Pressure psi (MPa, bar)	Length ft (m)	ID in. (mm)	Description	Old Part	Replaced By	JIC Fittings	
						"A" inlet (f)/ outlet (m)	"B" inlet (f)/ outlet (m)
<b>2 Component Whip Hoses - Individual Insulation with Air Hose</b>							
2000 (13.8, 138)	10 (3)	1/4 (6)	Whip hose with scuff guard	1250E-PL & 1250D-PL	246050	5/5	6/6
2000 (13.8, 138)	10 (3)	3/8 (10)	Whip hose with scuff guard	1230D-PL	246051	5/5	6/6
2000 (13.8, 138)	3 (0.9)	1/4 (6)	Whip hose with scuff guard	1250D-3-PL	249586	5/5	6/6
3500 (24.1, 241)	10 (3)	1/4 (6)	Whip hose with scuff guard	14250A-PL & 14250-PL	246055	5/5	6/6
3500 (24.1, 241)	10 (3)	3/8 (10)	Whip hose with scuff guard	14265-10-PL	246056	5/5	6/6

<b>Repair Hoses</b>							
2000 (13.8, 138)	50 (15.2)	1/4 (6)	Single hose, A (ISO) side	1227A-PL	246059	5/5	6/6
2000 (13.8, 138)	50 (15.2)	1/4 (6)	Single hose, B (RES) side	1226A-PL	246060	5/5	6/6
2000 (13.8, 138)	50 (15.2)	3/8 (10)	Single hose, A (ISO) side	1202-PL	246061	5/5	6/6
2000 (13.8, 138)	50 (15.2)	3/8 (10)	Single hose, B (RES) side	1201-PL	246062	5/5	6/6
2000 (13.8, 138)	50 (15.2)	1/2 (13)	Single hose, A (ISO) side	5227C-50-PL	246063	8/8	10/10
2000 (13.8, 138)	50 (15.2)	1/2 (13)	Single hose, B (RES) side	5226C-50-PL	246064	8/8	10/10
2000 (13.8, 138)	25 (7.6)	1/4 (6)	Single hose, A (ISO) side	1265A-PL	246065	5/5	6/6
2000 (13.8, 138)	25 (7.6)	1/4 (6)	Single hose, B (RES) side	1261A-PL	246066	5/5	6/6
2000 (13.8, 138)	25 (7.6)	3/8 (10)	Single hose, A (ISO) side	None	246094	5/5	6/6
2000 (13.8, 138)	25 (7.6)	3/8 (10)	Single hose, B (RES) side	None	246095	5/5	6/6
3500 (24.1, 241)	50 (15.2)	1/4 (6)	Single hose, A (ISO) side	None	246067	5/5	6/6
3500 (24.1, 241)	50 (15.2)	1/4 (6)	Single hose, B (RES) side	None	246068	5/5	6/6
3500 (24.1, 241)	50 (15.2)	3/8 (10)	Single hose, A (ISO) side	14232-50-PL	246069	5/5	6/6
3500 (24.1, 241)	50 (15.2)	3/8 (10)	Single hose, B (RES) side	14231-50-PL	246070	5/5	6/6
3500 (24.1, 241)	50 (15.2)	1/2 (13)	Single hose, A (ISO) side	14237-50-PL	246071	8/8	10/10
3500 (24.1, 241)	50 (15.2)	1/2 (13)	Single hose, B (RES) side	14236-50-PL	246072	8/8	10/10

			TSU is now FTS	20206-4	261669	See pg. 18 for fitting detail	
			Hose Power Jumper Plug	0684-3	15C517		

# Warnings

## Warning



### Skin Injection Hazard

High-pressure fluid from gun, hose leaks, or ruptured components will pierce skin. This may look like just a cut, but it is a serious injury that can result in amputation. **Get immediate surgical treatment.**







- Do not point the gun at anyone or at any part of the body.
- Do not put your hand or fingers over the gun fluid nozzle.
- Do not stop or deflect leaks with your hand, body, glove, or rag.
- Do not “blow back” fluid; this is not an air spray system.
- Follow **Pressure Relief Procedure** in your proportioner manual **Technical Data** when you stop spraying and before cleaning, checking, or servicing equipment.
- Use lowest possible pressure when flushing, priming, or troubleshooting.
- Engage spray gun piston safety lock when not spraying.
- Tighten all fluid connections before operating the equipment.
- Check hoses, tubes, and couplings daily. Replace worn or damaged parts immediately. High pressure hose cannot be recoupled; replace the entire hose.



### Fire, Explosion, and Electric Shock Hazard

Solvent and fumes in work area can ignite or explode. To help prevent fire, explosion, and electric shock:



- Use equipment only in well ventilated area.
- Eliminate all ignition sources, such as pilot lights, cigarettes and plastic drop cloths (potential static arc).
- Do not plug or unplug power cords or turn lights on or off when flammable fumes are present.
- Keep the work area free of debris, including solvent, rags, and gasoline.
- Ground equipment and conductive objects. See **Grounding** in your proportioner manual.
- Hold gun firmly to side of grounded pail when triggering into pail.
- Use only grounded hoses.
- If there is static sparking or you feel a shock, **stop operation immediately**. Do not use equipment until you identify and correct the problem.

 <b>Warning</b>	
	<p><b>Equipment Misuse Hazard</b> Misuse can cause serious injury or death.</p> <ul style="list-style-type: none"> <li>• For professional use only.</li> <li>• Use equipment only for its intended purpose. Call your Graco distributor for information.</li> <li>• Read manuals, warnings, tags, and labels before operating equipment. Follow instructions.</li> <li>• Check equipment daily. Repair or replace worn or damaged parts immediately.</li> <li>• Do not alter or modify equipment. Use only Graco parts and accessories.</li> <li>• Do not exceed the maximum working pressure or temperature rating of the lowest rated system component. See <b>Technical Data</b> in all equipment manuals.</li> <li>• Use fluids and solvents that are compatible with equipment wetted parts. See <b>Technical Data</b> in all equipment manuals. Read fluid and solvent manufacturer's warnings.</li> <li>• Route hoses and cables away from traffic areas, sharp edges, moving parts, and hot surfaces.</li> <li>• Do not use hoses to pull equipment.</li> <li>• Comply with all applicable safety regulations.</li> </ul>
	<p><b>Burn Hazard</b> This equipment is used with heated fluid, which can cause equipment surfaces to become very hot. To avoid severe burns:</p> <ul style="list-style-type: none"> <li>• Do not touch hot fluid or equipment.</li> <li>• Allow equipment to cool completely before touching it.</li> <li>• Wear gloves if fluid temperature exceeds 110°F (43°C).</li> </ul>
	<p><b>Toxic Fluid or fumes Hazard</b> Toxic fluids or fumes can cause serious injury or death if splashed in the eyes or on skin, inhaled, or swallowed.</p> <ul style="list-style-type: none"> <li>• Read Material Safety Data Sheet (MSDS) to know the specific hazards of the fluids you are using.</li> <li>• Store hazardous fluid in approved containers, and dispose of it according to applicable guidelines.</li> </ul>
	<p><b>Personal Protective Equipment</b> You must wear proper protective equipment when operating, servicing, or when in the operating area of the equipment to help protect you from serious injury, including eye injury; inhalation of toxic fumes; and hearing loss. This equipment includes but is not limited to:</p> <ul style="list-style-type: none"> <li>• Protective eyewear</li> <li>• Gloves, clothing, and respirator as recommended by the fluid and solvent manufacturer</li> <li>• Hearing protection.</li> </ul>

# Installation

## Description

 **WARNING**





This hose must be used with an FTS and cable to provide grounding. Read warnings, page 6.

The heated hose maintains proper fluid temperature while spraying.

Fluid hoses are marked with red tape for ISO/hardener/minor volume side, blue tape for RES/resin/major volume side. Fittings have different sized threads to prevent incorrect connection, which can cause fluid crossover and permanently damage the hose.

Hoses are 50 ft (15.2 m) or 25 ft (7.6 m) long. The whip hose is 10 ft (3 m) long.

 To heat the major volume hose only in a wide ratio system, see **15F144 Hose Wire Jumper**, page 21.

## Set Transformer Wire Taps

Transformer tap wire connections vary depending on proportioner and length of heated hose. See proportioner operation manual for further information. Some models are automatic and have no user-set taps. Verify that tap wire connections are correct.

Hose Length* ft (m)	Tap Terminal Label (ft)
50 - 85 (15.2 - 25.9)	50
100 - 135 (30.5 - 41.1)	100
150 - 185 (48.7 - 56.4)	150
200 - 235 (60.1 - 71.6)	200
250 - 285 (76.2 - 86.9)	250
300 - 310 (91.4 - 94.5)	300

\*Length includes heated fluid hose and whip hose.

## Connect Whip Hose to Gun or Gun Manifold

 For best whip hose flexibility, assemble whip hose to gun or gun manifold as instructed.

1. Assemble A and B component hoses to gun or gun manifold fittings as shown in FIG. 1.
2. Tighten fittings to A and B component hoses. Ensure hose remains flat after fittings are tightened. Loosen and retighten fittings as necessary to eliminate any torque on hoses. This will help achieve a flat profile on the hose.

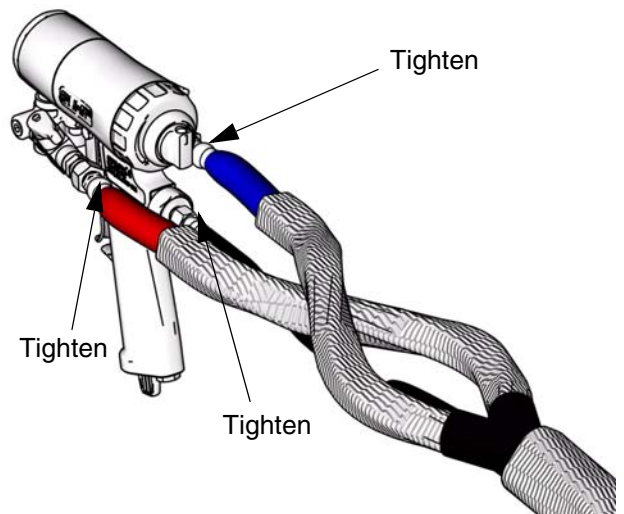

**FIG. 1**

## Connect Heated Hoses

**WARNING**



Read warnings, pages 6 and 7.

1. Lay heated hoses end to end, matching the color coding. Red for component A (ISO), blue for component B (RES).

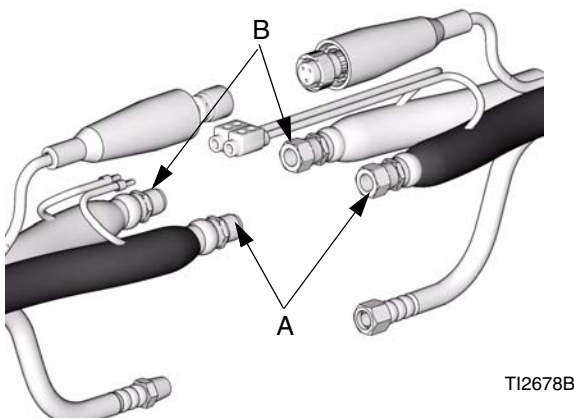

FIG. 2

2. Connect fluid hoses (A, B).

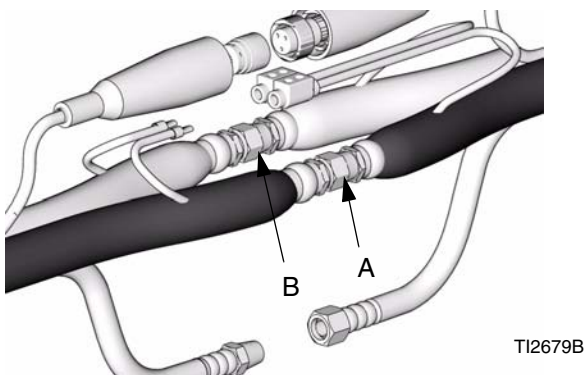

FIG. 3

Do not connect the main air supply to the air hose at this time.

Common insulated heated hoses do not contain an air hose.

3. Connect air hoses (C).

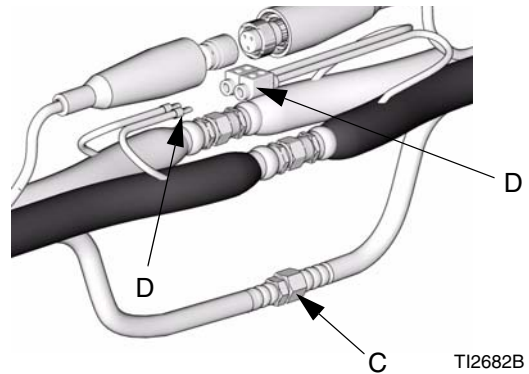

FIG. 4

4. Connect electrical wires.

- a. Ensure electrical wires ends are 5/8 in. (0.625mm) long. If they are not, use a sharp scissors to strip all four wire ends to the correct length. See Strip Length Gauge for correct length.

### Strip Length



T19733a

FIG. 5

Be careful not to cut or nick copper strands. If more than five strands are cut or nicked, trim wire and re-strip.

New hoses are pre-stripped at correct length; remove insulation to expose bare wire.

- a. Ensure strip length is correct by fitting ferrule over exposed wire. Ferrule should be flush with wire end. See FIG. 6.

 On some older heated hoses wire insulation will not fit inside ferrule insulator. In these cases, use scissors to split and remove ferrule insulator.

- b. If wire is short of ferrule end, adjust strip length accordingly. If bare wire is protruding from ferrule, trim flush to ferrule end. See FIG. 6.

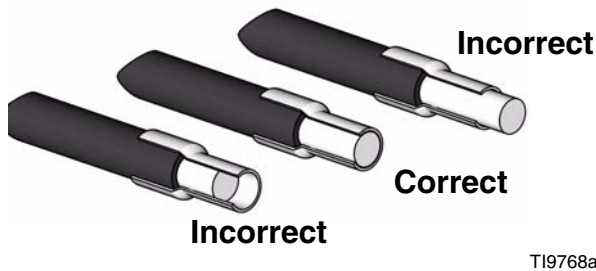

T19768a

**FIG. 6**

- c. Remove ferrule and apply oxide inhibitor to bare wire. See FIG. 7.
- d. Reinsert wire in ferrule and apply more oxide inhibitor to ferrule and wire end.



T19769A

**FIG. 7**

- 5. Pair electrical wires as follows: A-Hose to A-Hose; B-Hose to B-Hose.

 When connecting first hose section to proportioner, wire pairing does not make a difference.

- a. Insert one wire from heated hose into connector. Ensure that ferrule is mating with connector insert. See FIG. 8.

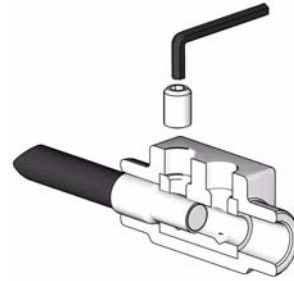

T19770A

**FIG. 8: Insert Wire and Setscrew**

- b. Thread in setscrew and use hex wrench to torque setscrew to 60 in-lbs (6.78 N•m).

 To reach approximately 60 in-lbs (6.78 N•m), complete 4.5 revolutions with hex wrench after setscrew comes in contact with ferrule.

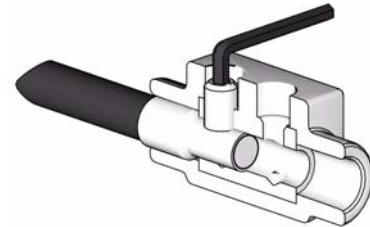

T19779A

**FIG. 9: Torque Setscrew**

- c. Insert remaining wire from pair into connector; ensure proper insertion depth. Thread setscrew and torque to 60 in-lbs (6.78 N•m); see sub-step B. See FIG. 8 and FIG. 9.
- d. Repeat sub-steps A through C for remaining wire pair.

- e. Re-torque all four setscrews to 60 in-lbs (6.78 N•m).

 When torqued to 60 in-lbs (6.78 N•m) setscrews will be approximately flush with connector. See FIG. 10.

- f. Insert cap plugs over setscrews. See FIG. 10.

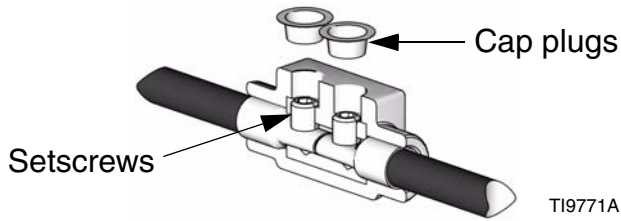

**FIG. 10**

- g. Wrap connector and wire on each side of connector in black electrical tape to help seal out moisture. Ensure 1 in. (25.4 mm) of wire on each side of connector is wrapped.

6. Connect cables (F). Slide insulator sleeves over connection. Leave slack (G) in cables as stress relief to prevent cable failure.

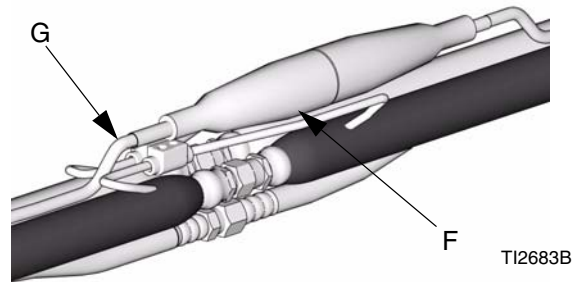

**FIG. 11**

7. Repeat for additional hoses.
8. See **Connect 261669 FTS and Heated Dual Whip Hose**, page 13, or **Connect 261670 FTS**, page 14.

## Connect 261669 FTS and Heated Dual Whip Hose

**⚠ CAUTION**  
 To prevent damage to probe, do not kink or excessively bend hose. Do not coil hose tighter than the minimum bend radius of 3 ft (0.9 m). Do not subject hose to excessive weight, impact, or other abuse.

- Carefully extend FTS probe (H) into the hose section from the proportioner. Do not bend or kink probe. Insert in component A (ISO) side of main hose for foam or polyurea systems.
- Connect FTS (J) to whip hose (W).
- Connect whip hose ground wire (K) to ground screw on underside of FTS.
- Connect fluid hoses to FTS (J).  
 To use 1/2 in. (13 mm) ID fluid hoses, remove the adapters from the proportioner fluid manifold and install them in the FTS swivel inlets.
- Connect electrical connectors (D).
- Connect air hose (C) to whip air hose (L).
- Connect hose assembly cable (F) to FTS cable (R). Slide insulator sleeves (S) over connection. Leave slack (G) in cables as stress relief, to prevent cable failure.
- See **Check Hoses for Leaks**, page 15

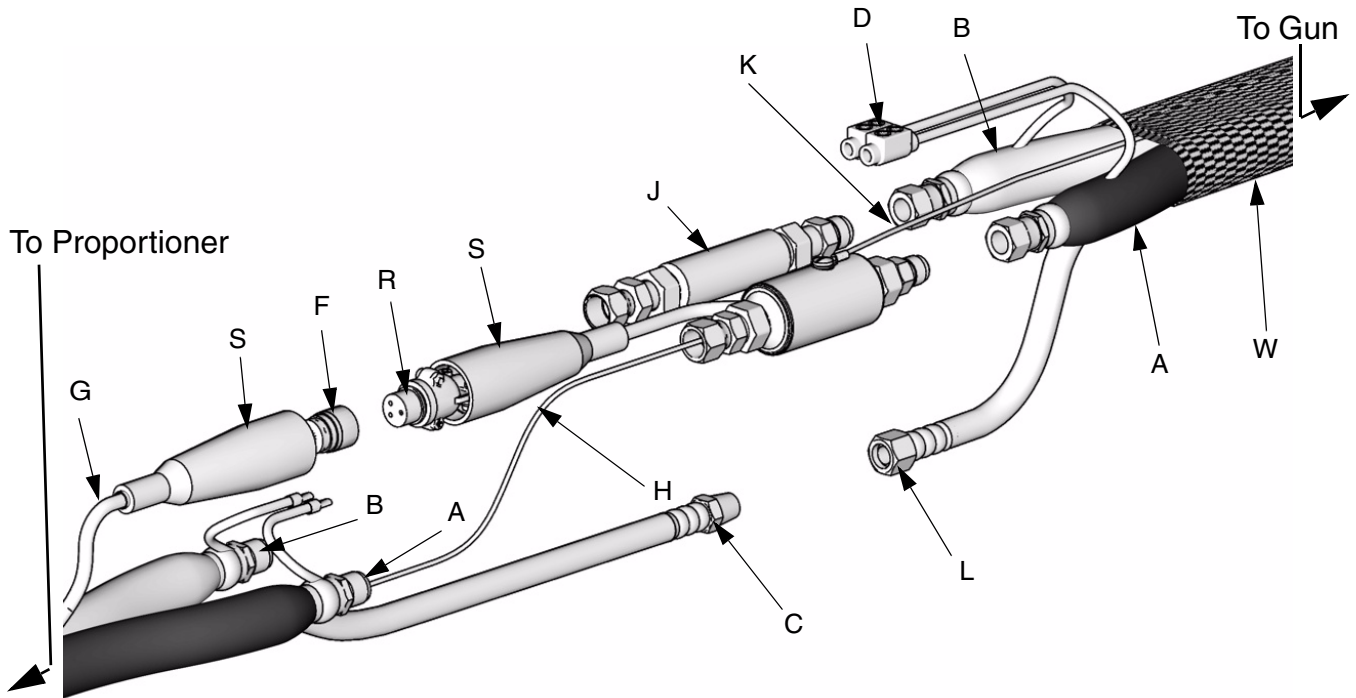

T19581B

## Connect 261670 FTS

### ⚠ CAUTION

Do not coil hose tighter than the minimum bend radius of 3 ft (0.9 m). Do not subject hose to excessive weight, impact, or other abuse.

1. Carefully extend FTS probe (H) into the hose section from the proportioner. Do not bend or kink probe. **Insert probe in major volume (resin) side on systems which are not 1:1 mix ratio.**
2. Connect FTS (J) to mix manifold.
3. Connect fluid hoses to FTS (J).  
 To use 1/2 in. (13 mm) ID fluid hoses, remove the adapters from the proportioner fluid manifold and install them in the FTS swivel inlets.
4. Install one connector (D) between wires.
5. Connect hose assembly cable (F) to FTS cable (R). Slide insulator sleeves (S) over connection. Leave slack (G) in cables as stress relief, to prevent cable failure.
6. See **Check Hoses for Leaks**, page 15.

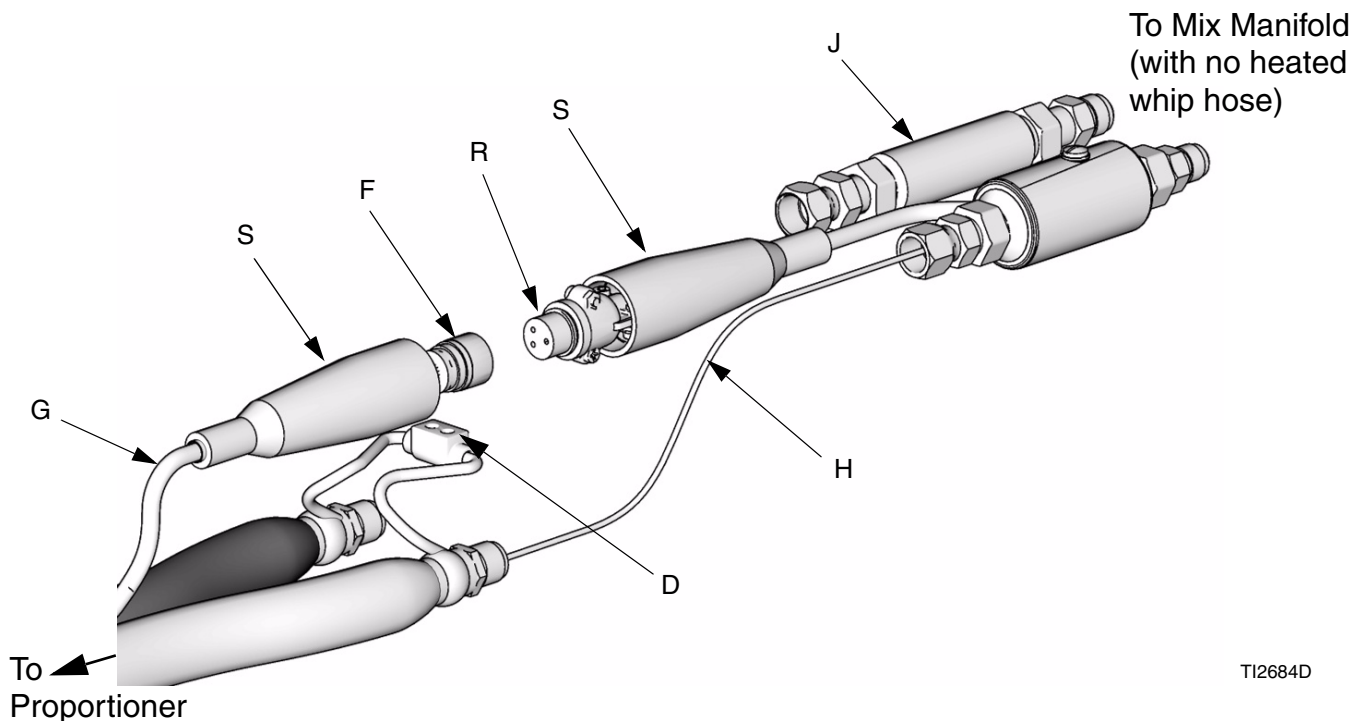

TI2684D

## Check Hoses for Leaks

1. Grease with Fusion grease and connect fluid hoses to proportioner fluid manifold (M). Red for hardener (ISO), blue for resin (RES).



The manifold hose adapters (N, P) allow use of 1/4 in. and 3/8 in. ID fluid hoses. To check adapter tightness, torque as follows:

- A side (N) to 20-25 ft-lb (27-34 N•m).
- B side (P) to 30-35 ft-lb (41-47 N•m).

To use 1/2 in. (13 mm) ID fluid hoses, remove the adapters from the proportioner fluid manifold and install them in the FTS swivel inlets.

2. For spray guns, close fluid valves on gun fluid manifold. Remove manifold from gun, see gun manual. Connect fluid whip hoses to manifold.
3. Check that all equipment is properly grounded. See proportioner manual.
4. Pressure check hose. See proportioner manual for priming instructions. After all lines are free of air, check for leaks. If there are leaks, relieve pressure as instructed in proportioner manual. Tighten connections, then pressurize again to ensure leaks have stopped. Relieve pressure.

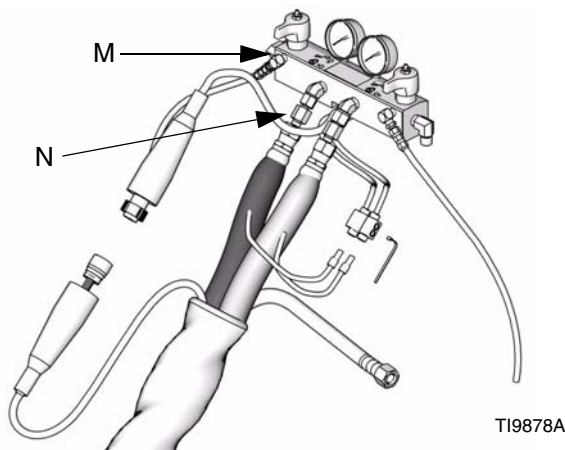

**FIG. 12**

## Protective Covering

1. Wrap **all** fluid hose connections with electrical tape.

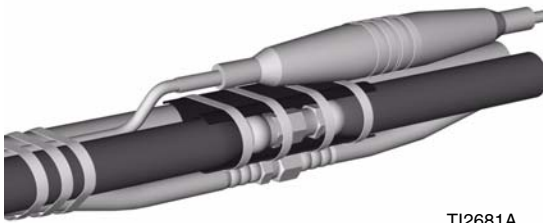

T12681A

**FIG. 13**

---

2. Fold wire back on hose to ensure adequate strain relief. Wrap **all** electrical connections and cable connections with electrical tape to protect them from pulling apart and abrasion.

3. Install protective cover (see **Accessories**, page 23), or wrap hose bundle with duct tape to protect foam.
4. For hoses that include a protective scuff cover, unroll excess cover over hose and electrical connections. Tape securely.

# Operation

**WARNING**

Read warnings, pages 6 and 7.

Do not operate a coiled hose. A coiled hose creates uneven heat buildup which can result in hose rupture and cause serious injury, including fluid injection.

Maximum hose operating temperature is 180°F (82°C). If using hose without an FTS, measure hose temperature to ensure it does not exceed 180°F (82°C).

Hose must be properly supported to avoid excessive strain due to weight, bending, sharp edges, or stress caused by running over a roof edge.

1. Connect air hose (C) to main air supply if equipped.
2. Connect electrical connectors (D) to connector from fluid manifold (M) or accessory control box. See **Connect Heated Hoses**, page 10. Connect hose cable (F) to cable from proportioner fluid manifold (M) or accessory control box. Wrap connections with electrical tape.

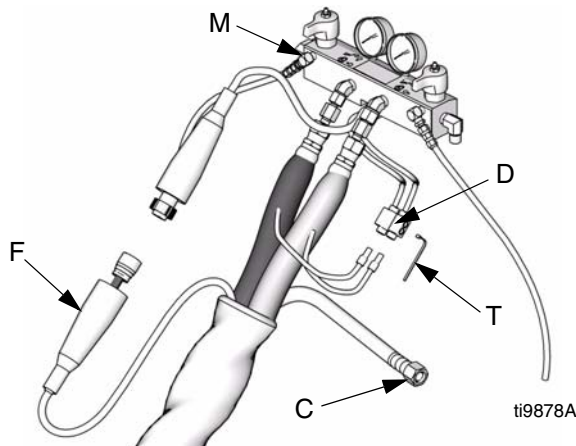

FIG. 14

3. Connect to spray gun. See gun manual.
4. Connect whip air hose to gun air inlet if equipped. See gun manual.
5. Follow setup, startup, and operation procedures in proportioner manual.

## Fluid Temperature Sensor (FTS) Calibration

Calibrate the FTS ONLY at initial startup (the first time the unit is operated) and any time the hose length changes.

1. Before turning on the unit, ensure all hoses and cables are properly connected. To ensure that the FTS in the hose is at the same temperature as the heaters, keep heat off and store the hose FTS near the machine for several minutes.
2. While holding down the temperature unit button (Fahrenheit - "F" or Celsius - "C") turn the proportioner main power ON.
3. Hold the temperature unit button until temperature is shown on the display. The fluid temperature sensor is now correctly calibrated.

## Maintenance

**WARNING**

Read warnings, pages 6 and 7.

1. Before disconnecting or repairing hoses, relieve all fluid pressure and shut off electrical power to proportioner. See proportioner operation manual.
2. Be sure fluid is cool before disconnecting hoses.

# Parts

## Using 261669 Fluid Temperature Sensor (JIC to JIC fittings)

Heated Fluid Hose

Fluid Temperature Sensor

Whip Hose

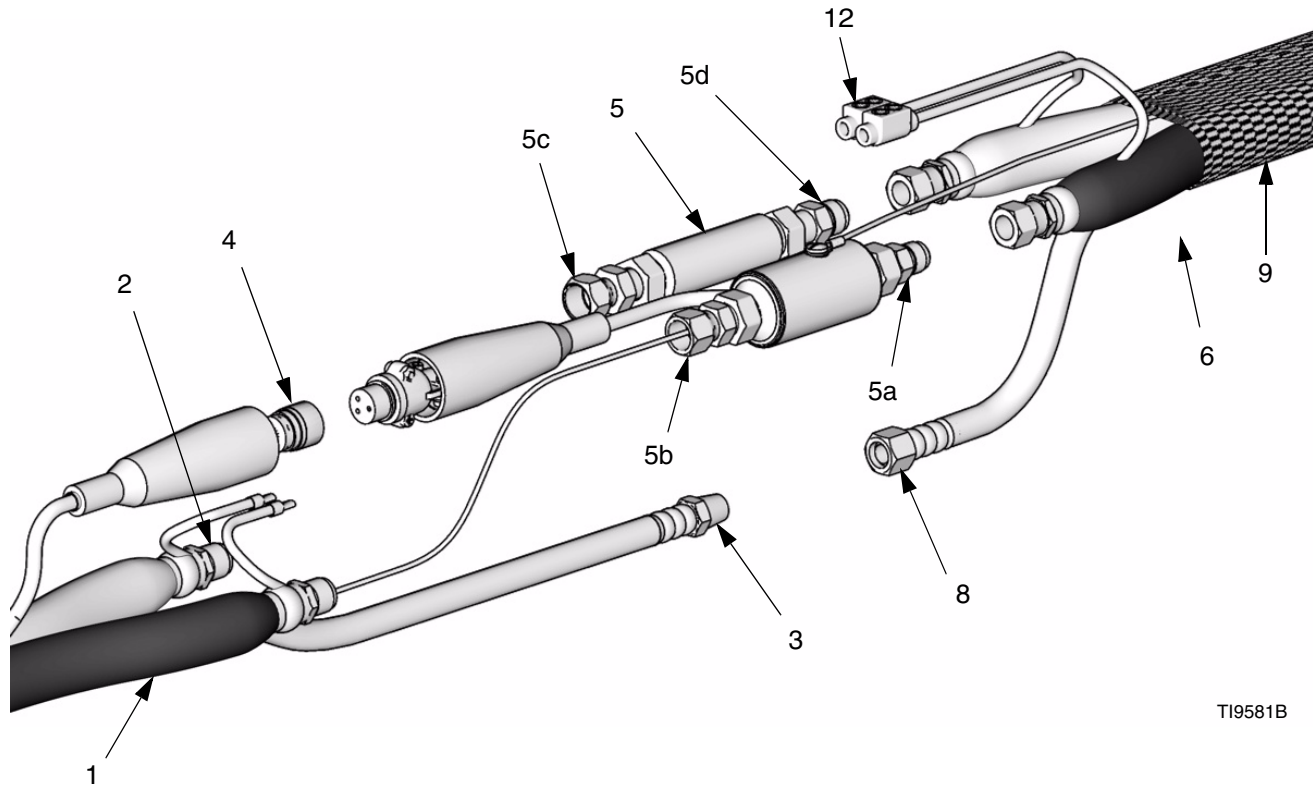

TI9581B

Ref. Part	Description	Qty	Ref. Part	Description	Qty
1	chart 1, HOSE, component A (ISO) page 20	1	6	chart 6, HOSE, whip page 20	1
2	chart 2, HOSE, component B (RES) page 20	1	8	15B280 HOSE, whip, air; 10 ft (3 m)	1
3	15B295 HOSE, air; 50 ft (15.2 m)	1	9	256735 SCUFF GUARD; 7 ft (2.1 m); included on whip hoses only	1
	15C624 HOSE, air; 25 ft (7.6 m)	1	12	261821 CONNECTOR, electrical; on main hose sections	1
4	15B296 CABLE, FTS; 50 ft (15.2 m)	1			
	15C626 CABLE, FTS; 25 ft (7.6 m)	1			
5	261669 FLUID TEMPERATURE SENSOR; includes items 5a-5d	1			
5a	117455 . NIPPLE; 1/4 npt(m) x #5 JIC (m)	1			
5b	117595 . SWIVEL; 1/4 npt(m) x #5 JIC (f)	1			
5c	117506 . SWIVEL; 1/4 npt(m) x #6 JIC (f)	1			
5d	116704 . NIPPLE; 1/4 npt(m) x #6 JIC (m)	1			

# Using 261670 Fluid Temperature Sensor (JIC to NPT fittings)

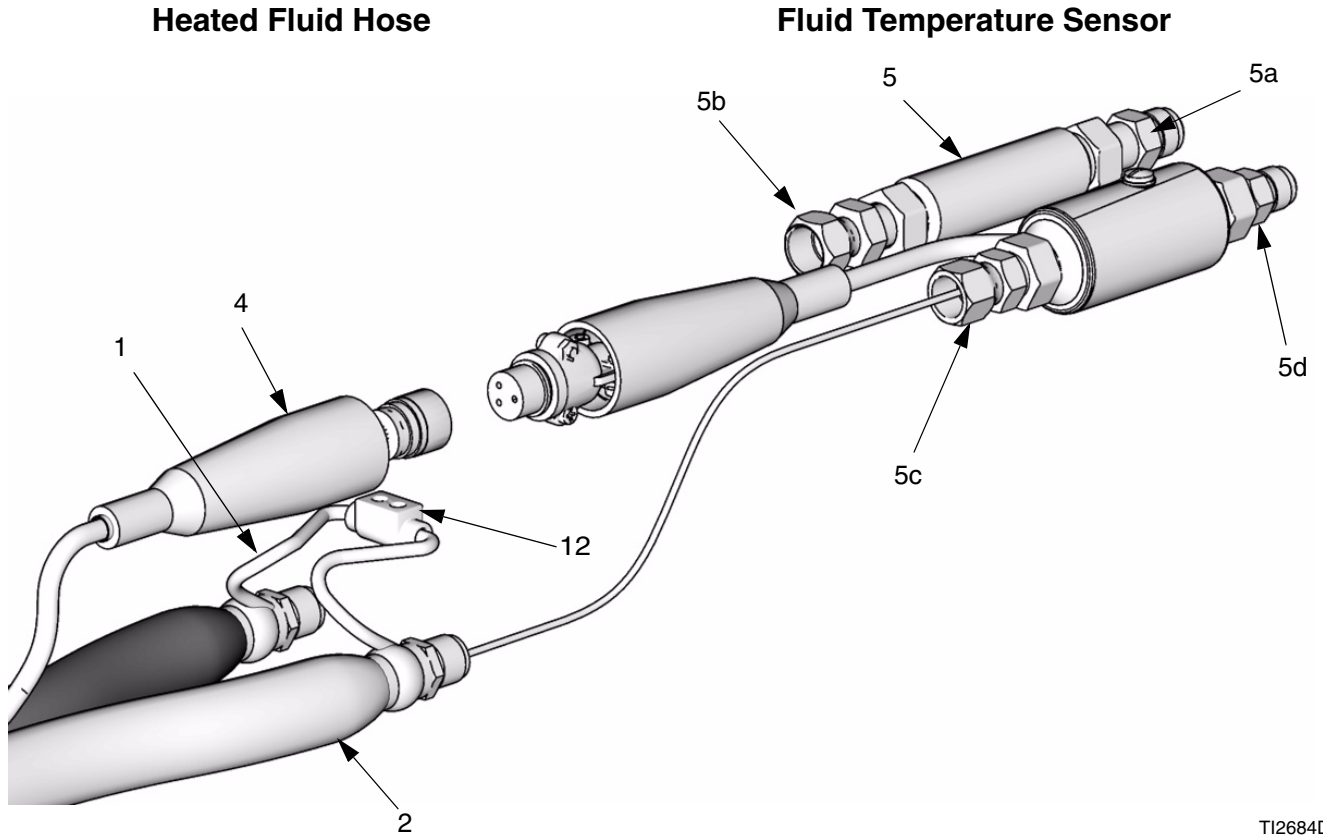

TI2684D

Ref.	Part	Description	Qty	Ref.	Part	Description	Qty
1	chart 1, page 20	HOSE, component A (ISO)	1	5c	117506	. SWIVEL; 1/4 npt(m) x #6 JIC (f)	1
2	chart 2, page 20	HOSE, component B (RES)	1	5d	157705	. SWIVEL; 1/4 npt(m) x 3/8 npsm(f)	1
4	15B296	CABLE, FTS; 50 ft (15.2 m)	1	12	261821	CONNECTOR, electrical; on main hose sections	1
	15C626	CABLE, FTS; 25 ft (7.6 m)	1				
5	261670	FLUID TEMPERATURE SENSOR; includes items 5a-5d	1				
5a	156823	. SWIVEL; 1/4 npt (m x f)	1				
5b	117595	. SWIVEL; 1/4 npt(m) x #5 JIC (f)	1				

 See the tables on pages 3 and 4 for fitting sizes.

**Chart for Ref. No. 1, Single Hardener (ISO) Hose**

Hose Part	Diameter in. (mm)	Length ft (m)	Maximum Fluid Pressure psi (MPa, bar)
246059	1/4 (6)	50 (15.2)	2000 (13.8, 138)
246061	3/8 (10)	50 (15.2)	2000 (13.8, 138)
246063	1/2 (13)	50 (15.2)	2000 (13.8, 138)
246065	1/4 (6)	25 (7.6)	2000 (13.8, 138)
246094	3/8 (10)	25 (7.6)	2000 (13.8, 138)
246067	1/4 (6)	50 (15.2)	3500 (24.1, 241)
246069	3/8 (10)	50 (15.2)	3500 (24.1, 241)
246071	1/2 (13)	50 (15.2)	3500 (24.1, 241)
15E750	1/4 (6)	50 (15.2)	5000 (34.5, 345)
15E751	3/8 (10)	50 (15.2)	5000 (34.5, 345)

**Chart for Ref. No. 2, Single Resin (RES) Hose**

Hose Part	Diameter in. (mm)	Length ft (m)	Maximum Fluid Pressure psi (MPa, bar)
246060	1/4 (6)	50 (15.2)	2000 (13.8, 138)
246062	3/8 (10)	50 (15.2)	2000 (13.8, 138)
246064	1/2 (13)	50 (15.2)	2000 (13.8, 138)
246066	1/4 (6)	25 (7.6)	2000 (13.8, 138)
246095	3/8 (10)	25 (7.6)	2000 (13.8, 138)
246068	1/4 (6)	50 (15.2)	3500 (24.1, 241)
246070	3/8 (10)	50 (15.2)	3500 (24.1, 241)
246072	1/2 (13)	50 (15.2)	3500 (24.1, 241)
15E752	3/8 (10)	50 (15.2)	5000 (34.5, 345)

**Instructions for Replacing Individual A or B Hose**

Before disconnecting hoses, relieve all fluid pressure and shut off electrical power to proportioner. See proportioner operation manual.

Disconnect electrical wire from connectors (12). Disconnect fluid hose and remove from bundle.

Install new hose in bundle, wrapping around other fluid hose and air hose. Connect fluid hoses, see page 10.

Connect electrical wire from new hose into connectors (12). Ensure that component A (ISO) wire is on + side of connector, component B (RES) wire is on - side. See page 10.

Wrap all connections with electrical tape, see page 16.

**Chart for Ref. No. 6, Dual Whip Hose**

Hose Part	Diameter in. (mm)	Length ft (m)	Maximum Fluid Pressure psi (MPa, bar)
246050	1/4 (6)	10 (3)	2000 (13.8, 138)
246051	3/8 (10)	10 (3)	2000 (13.8, 138)
246055	1/4 (6)	10 (3)	3500 (24.1, 241)
246056	3/8 (10)	10 (3)	3500 (24.1, 241)

# 15F144 Hose Wire Jumper





Use the 15F144 Hose Wire Jumper to heat only the major volume hose, in a wide ratio system.

To build one complete 50 ft single side heated hose bundle, order the following parts:

Ref.	Part	Description	Qty
100	15F144	JUMPER, hose wire; includes two 117789 electrical connectors; 50 ft (15.2 m) long	1
101	chart 2, page 20	HOSE, resin, heated; 50 ft (15.2 m) minimum	1
102	15B296	CABLE, FTS	1
103	15C517	HARNESS, hose jumper	1
104	261670	FLUID TEMPERATURE SENSOR; see page 19	1
105	purchase locally	HOSE, hardener, unheated; 50 ft (15.2 m) minimum; customer supplied	1
106	purchase locally	CONNECTORS, fluid; as required to complete assembly; not shown	as req'd

Install as follows:

**⚠ WARNING**

Read warnings, pages 6 and 7.

Hoses (101 and 105) must be sized and pressure rated to meet the requirements of your system.

Do not operate heated hose (101) at more than 45 A. If hose is cold, turn current adjustment fully counterclockwise before reheating hose.

Spray gun must be grounded.

1. Wrap hose wire jumper (100) around resin hose (101) in a spiral fashion.
2. Connect resin hose wire (101a) to other side of Power-Lock connector (100a); see page 10.
3. Wrap FTS cable (102) around resin hose (101) in a spiral fashion.
4. Twist hoses (101 and 105) together to provide strain relief.
5. Repeat steps 1-4 for each length of hose (101). Connect hoses, electrical connectors, and cables; see **Connect Heated Hoses**, page 10.
6. Install one -Lock connector (100a) between wires; see page 10.

7. **Connect 261670 FTS**, page 14.
8. Install whip hose and gun. Ensure that gun is grounded.
9. Connect hoses to proportioner.
10. Insulate and protect hoses. See **Protective Covering**, page 16.

11. Set transformer wire taps, using the following table. Transformer tap wire connections vary depending on length of heated hose. See proportioner operation manual for further information. Verify that tap wire connections are correct.

Single Side Heated Hose Length, ft (m)	Tap Terminal Label (ft)
50 (15.2)	50
100 (30.5)	50
150 (48.7)	100
200 (61.0)	100
250 (76.2)	150
300 (91.5)	150
350 (106.8)	200
400 (122.0)	200

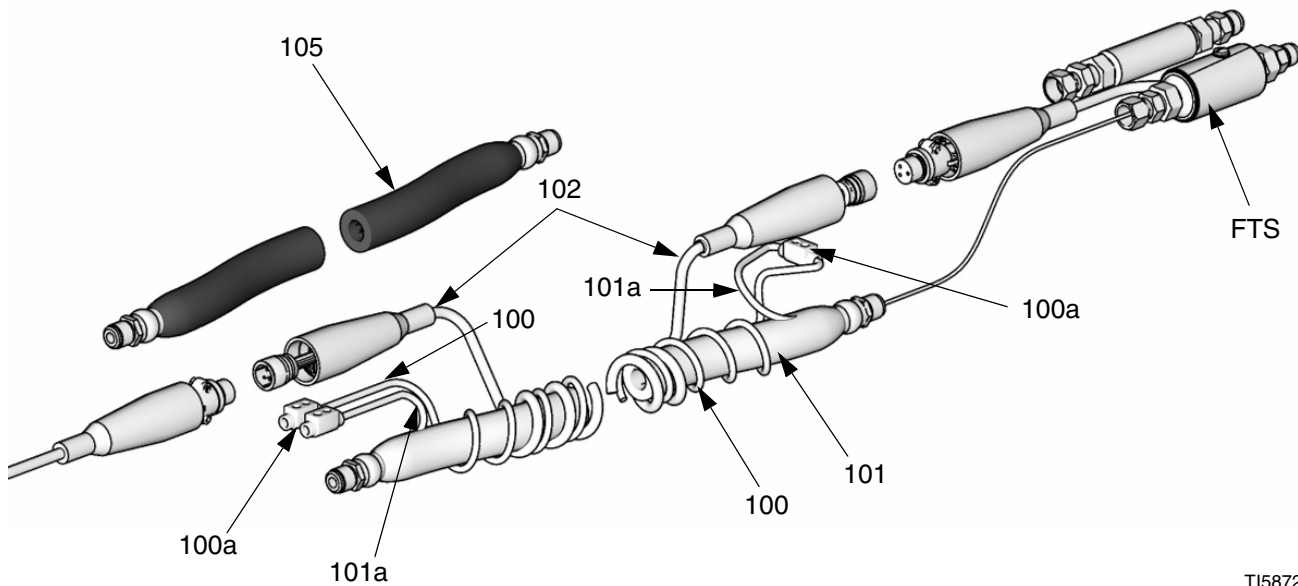

TI5872C

## Technical Data

Category	Data
Maximum Fluid Working Pressure	See page 3
Maximum Air Working Pressure	130 psi (0.9 MPa, 9 bar)
Maximum Operating Temperature	180°F (82°C)
Wetted Parts	Nylon, Zinc-Plated Carbon Steel, 303 Stainless Steel
Total Heating Load (2 hoses)	1/4" diameter: 11 watts/foot (36 watts/meter) 3/8" diameter: 13 watts/foot (43 watts/meter) 1/2" diameter: 15 watts/foot (49 watts/meter)

## Accessories

### Scuff Guard

Use to keep hose clean and protect it from damage.

Part	Description
256735	7 ft (2.1 m) braided polyester mesh. For whip hose. Fold back over itself for easy installation.
246078	50 ft (15.2 m) braided polyester mesh. Fold back over itself for easy installation.
246805	25 ft (7.6 m) braided polyester mesh. Fold back over itself for easy installation.
246456	50 ft (15.2 m) polyethylene bag. Inflate with air for easy installation.

# Warranty

Graco warrants all equipment referenced in this document which is manufactured by Graco and bearing its name to be free from defects in material and workmanship on the date of sale to the original purchaser for use. With the exception of any special, extended, or limited warranty published by Graco, Graco will, for a period of twelve months from the date of sale, repair or replace any part of the equipment determined by Graco to be defective. This warranty applies only when the equipment is installed, operated and maintained in accordance with Graco's written recommendations.

This warranty does not cover, and Graco shall not be liable for general wear and tear, or any malfunction, damage or wear caused by faulty installation, misapplication, abrasion, corrosion, inadequate or improper maintenance, negligence, accident, tampering, or substitution of non-Graco component parts. Nor shall Graco be liable for malfunction, damage or wear caused by the incompatibility of Graco equipment with structures, accessories, equipment or materials not supplied by Graco, or the improper design, manufacture, installation, operation or maintenance of structures, accessories, equipment or materials not supplied by Graco.

This warranty is conditioned upon the prepaid return of the equipment claimed to be defective to an authorized Graco distributor for verification of the claimed defect. If the claimed defect is verified, Graco will repair or replace free of charge any defective parts. The equipment will be returned to the original purchaser transportation prepaid. If inspection of the equipment does not disclose any defect in material or workmanship, repairs will be made at a reasonable charge, which charges may include the costs of parts, labor, and transportation.

**THIS WARRANTY IS EXCLUSIVE, AND IS IN LIEU OF ANY OTHER WARRANTIES, EXPRESS OR IMPLIED, INCLUDING BUT NOT LIMITED TO WARRANTY OF MERCHANTABILITY OR WARRANTY OF FITNESS FOR A PARTICULAR PURPOSE.**

Graco's sole obligation and buyer's sole remedy for any breach of warranty shall be as set forth above. The buyer agrees that no other remedy (including, but not limited to, incidental or consequential damages for lost profits, lost sales, injury to person or property, or any other incidental or consequential loss) shall be available. Any action for breach of warranty must be brought within two (2) years of the date of sale.

**GRACO MAKES NO WARRANTY, AND DISCLAIMS ALL IMPLIED WARRANTIES OF MERCHANTABILITY AND FITNESS FOR A PARTICULAR PURPOSE, IN CONNECTION WITH ACCESSORIES, EQUIPMENT, MATERIALS OR COMPONENTS SOLD BUT NOT MANUFACTURED BY GRACO.** These items sold, but not manufactured by Graco (such as electric motors, switches, hose, etc.), are subject to the warranty, if any, of their manufacturer. Graco will provide purchaser with reasonable assistance in making any claim for breach of these warranties.

In no event will Graco be liable for indirect, incidental, special or consequential damages resulting from Graco supplying equipment hereunder, or the furnishing, performance, or use of any products or other goods sold hereto, whether due to a breach of contract, breach of warranty, the negligence of Graco, or otherwise.

## **FOR GRACO CANADA CUSTOMERS**

The Parties acknowledge that they have required that the present document, as well as all documents, notices and legal proceedings entered into, given or instituted pursuant hereto or relating directly or indirectly hereto, be drawn up in English. Les parties reconnaissent avoir convenu que la rédaction du présente document sera en Anglais, ainsi que tous documents, avis et procédures judiciaires exécutés, donnés ou intentés, à la suite de ou en rapport, directement ou indirectement, avec les procédures concernées.

# Graco Phone Numbers

**TO PLACE AN ORDER**, contact your Graco distributor, or call this number to identify the distributor closest to you: **1-800-328-0211 Toll Free**  
**612-623-6921**  
**612-378-3505 Fax**

*All written and visual data contained in this document reflects the latest product information available at the time of publication.  
Graco reserves the right to make changes at any time without notice.*

*This manual contains English. MM 309572*

**Graco Headquarters:** Minneapolis  
**International Offices:** Belgium, China, Japan, Korea

**GRACO INC. P.O. BOX 1441 MINNEAPOLIS, MN 55440-1441**

Copyright 2002, Graco Inc. is registered to ISO 9001

www.graco.com  
Revised 1/2009