

FUSION™

309856E

Plural Component, Impingement Mix Mechanical Purge Spray Gun

**For use with non-flammable foam and polyurea.
Not for use in explosive atmospheres.**

3500 psi (24.2 MPa, 242 bar) Maximum Fluid Working Pressure

80-130 psi (0.55-0.9 MPa, 5.5-9.1 bar) Air Inlet Pressure Range

200° F (94° C) Maximum Fluid Temperature

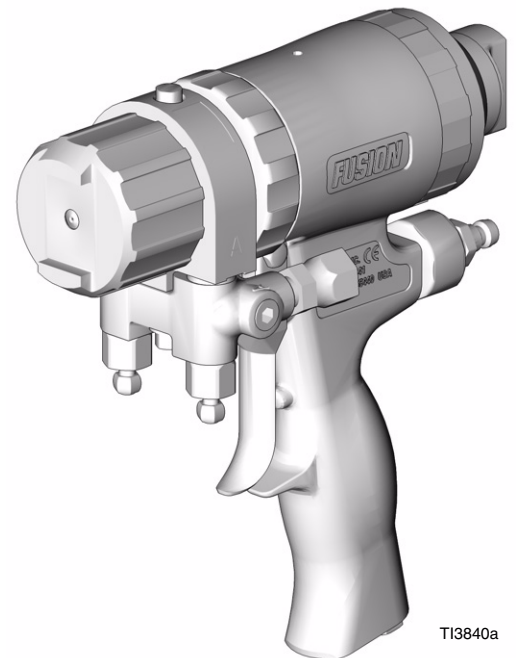

TI3840a

US Patent Number D479,305
Korean Patent 338185
Australian Patent Number 152610

PROVEN QUALITY. LEADING TECHNOLOGY.

Graco Inc. P.O. Box 1441 Minneapolis, MN 55440-1441
Copyright 2003, Graco Inc. is registered to I.S. EN ISO 9001





Contents

Manual Conventions	3	Adjust Front Rod Seal	27
List of Models/Selection Guide	4	Adjust Rear Rod Seal	28
Standard Round Pattern Guns	4	Troubleshooting	29
Standard Flat Pattern Guns	5	Theory of Operation	31
Direct Impingement Round Pattern Guns	6	Cutaway View	32
Direct Impingement Flat Pattern Guns	7	Repair	33
Direct Impingement Flat Pattern Guns	8	Tools Required	33
Warning	9	Lubrication	33
Overall View	11	Replace CeramTip	33
Isocyanate Hazard	12	Disassemble Front End	34
Keep A and B Components Separate	12	Reassemble Front End	35
Grounding	12	Slip-Fit Polycarbally Mix Module	37
Piston Safety Lock	12	Rear Rod Seal	39
Loss of Air Pressure	12	Check Valves	40
Setup	13	Piston and Purge Rod	41
Adjust Purge Rod	15	Piston Safety Lock	43
Adjust Flat CeramTip	16	Air Valve	43
Shutdown	17	Parts	44
Daily Shutdown	17	Slip-Fit Polycarbally Mix Module Kits	46
Shutdown for More than a Day	17	CeramTip Kits	48
Pressure Relief Procedure	18	Drill Bit Kits	49
Optional Configurations	19	Gun Repair Kits	50
Optional Fluid Manifold Position	19	Check Valve Filter Screen Kits (10 per kit)	50
Optional Hose Position	20	Accessories	51
Maintenance	21	Gun Cover	51
Supplied Tool Kit	21	Fusion Gun Lubricant Kit	51
Keep Gun Clean	21	Tip Cleanout Tool	51
As Needed	21	Circulation Manifold	51
Daily	21	Flushing Manifold	51
Weekly to Monthly	21	Solvent Flush Kits	51
Flush Gun	22	Solvent Flush Pail Kit	52
Clean Outside of Gun	22	Hose Adapter Kits	52
Clean Air Cap	22	Pour Nozzle Kit	52
Clean Muffler	22	Technical Data	53
Clean Fluid Manifold	22	Graco Standard Warranty	54
Clean Slip-Fit Polycarbally Mix Module	23	Graco Information	54
Clean CeramTip	25		
Stuck Purge Rod	26		
Clean Purge Rod	26		

Manual Conventions

Warning

 WARNING
 
<p>A warning alerts you to possible serious injury or death if you do not follow instructions.</p> <p>Symbols, such as fluid injection (shown), alert you to a specific hazard and direct you to read the indicated hazard warnings on pages 9-10.</p>

Caution

CAUTION
A caution alerts you to possible equipment damage or destruction if you do not follow instructions.

Note

 A note indicates additional helpful information.

List of Models/Selection Guide

Standard Round Pattern Guns

 Use only these mix module/tip combinations.

Gun Part No., Series	Slip-Fit™ Polycarbally™ Mix Module Part No., see page 46 for numbering code	Round CeramTip™ Part No., see page 48 for numbering code
247211, A	MR3535	RTM030
247212, A	MR3535	RTM040
247213, A	MR3535	RTM055
247218, A	MR4747	RTM040
247219, A	MR4747	RTM055
247225, A	MR5757	RTM055
247226, A	MR5757	RTM070
247231, A	MR6666	RTM070
247232, A	MR6666	RTM080
247233, A	MR6666	RTM090
247239, A	MR8282	RTM090
247240, A	MR8282	RTM100
247245, A	MR9494	RTM100
247246, A	MR9494	RTM110

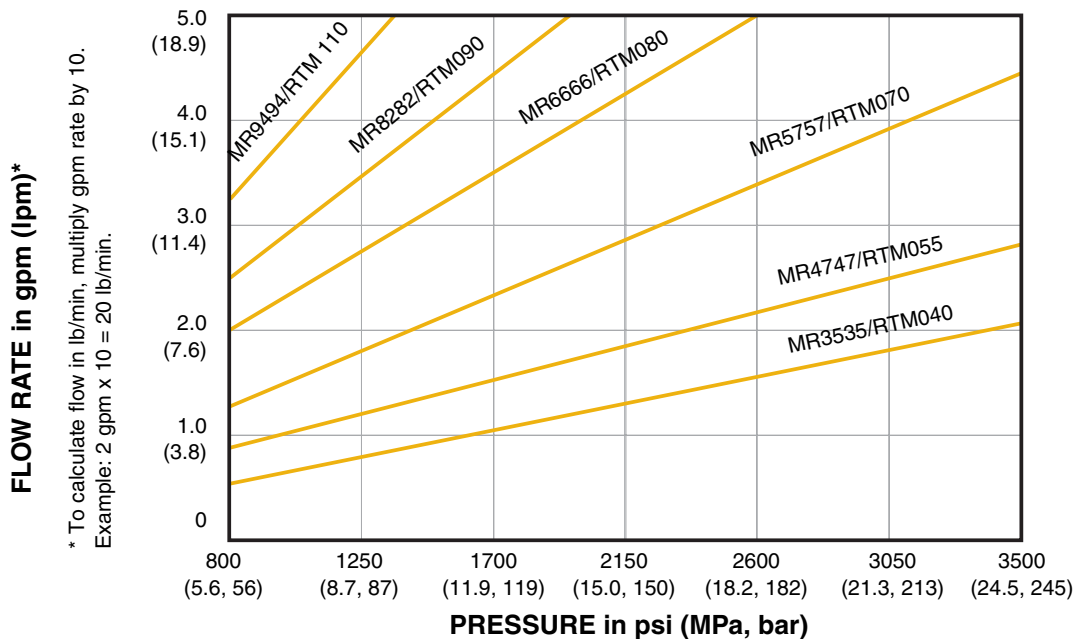

Standard Flat Pattern Guns



Use only these mix module/tip combinations.

Gun Part No., Series	Slip-Fit™ Polycarballoy™ Mix Module Part No., see page 46 for numbering code	Flat CeramTip™ Part No., see page 48 for numbering code
247257, A	MF1818	FTM317
247258, A	MF1818	FTM424
247265, A	MF2929	FTM424
247266, A	MF2929	FTM438
247267, A	MF2929	FTM624
247273, A	MF3535	FTM438
247274, A	MF3535	FTM624
247275, A	MF3535	FTM638
247281, A	MF4747	FTM624
247282, A	MF4747	FTM638
247283, A	MF4747	FTM838
247289, A	MF5757	FTM638
247290, A	MF5757	FTM838
247291, A	MF5757	FTM848

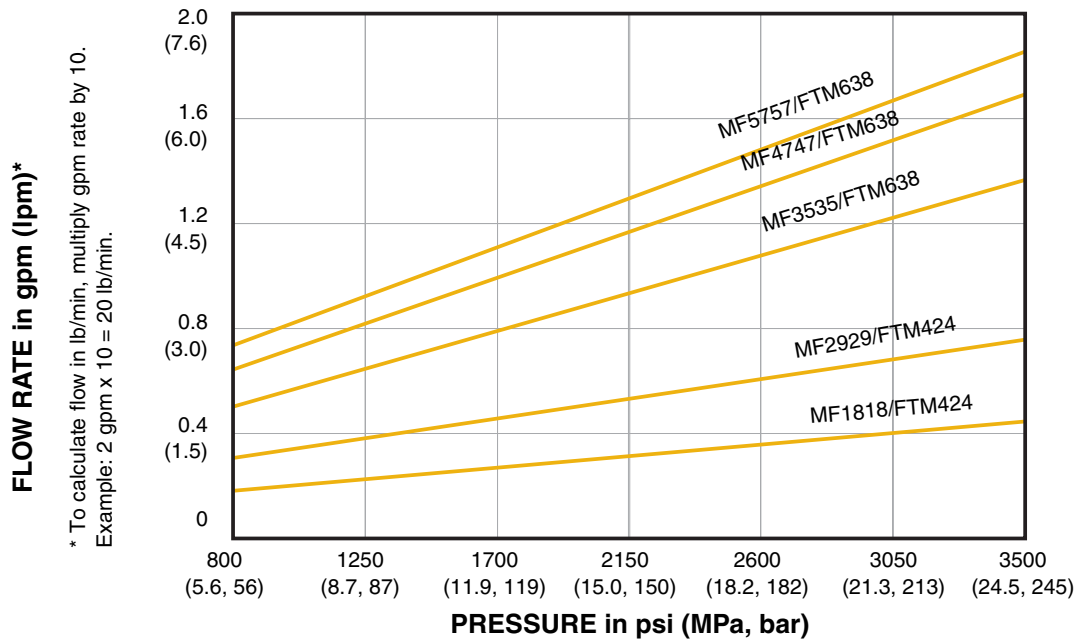

Direct Impingement Round Pattern Guns

 Use only these mix module/tip combinations.

Gun Part No., Series	Slip-Fit™ Polycarballoy™ Mix Module Part No., see page 46 for numbering code	Round CeramTip™ Part No., see page 48 for numbering code
247003, A	XR2323	RTM040
247006, A	XR2929	RTM030
247007, A	XR2929	RTM040
247011, A	XR3535	RTM030
247012, A	XR3535	RTM040
247013, A	XR3535	RTM055
247018, A	XR4747	RTM040
247019, A	XR4747	RTM055
247025, A	XR5757	RTM055
247026, A	XR5757	RTM070

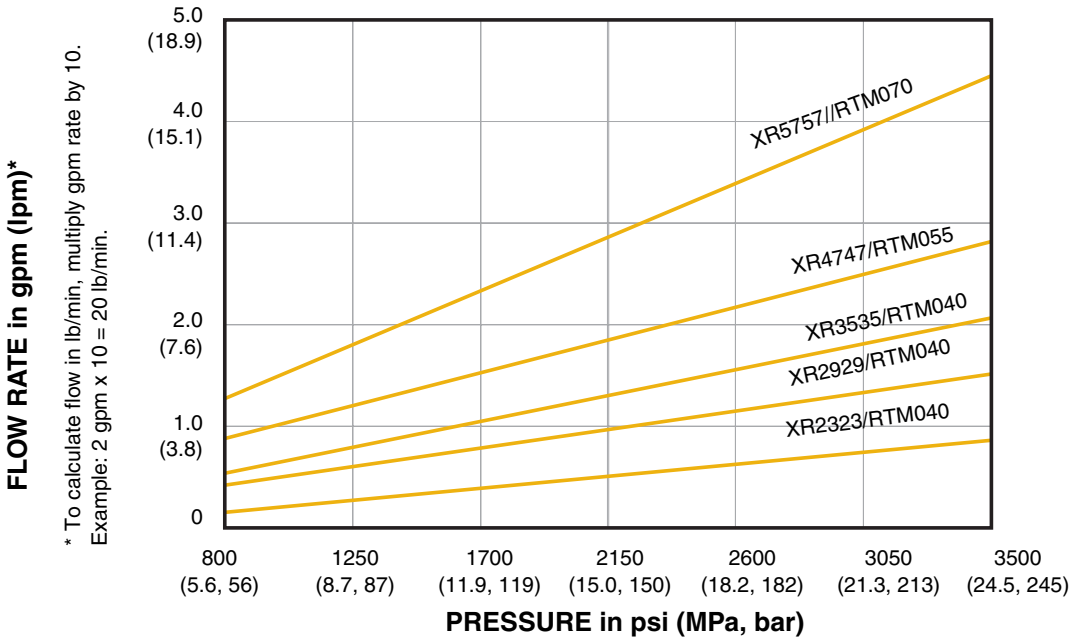

Direct Impingement Flat Pattern Guns





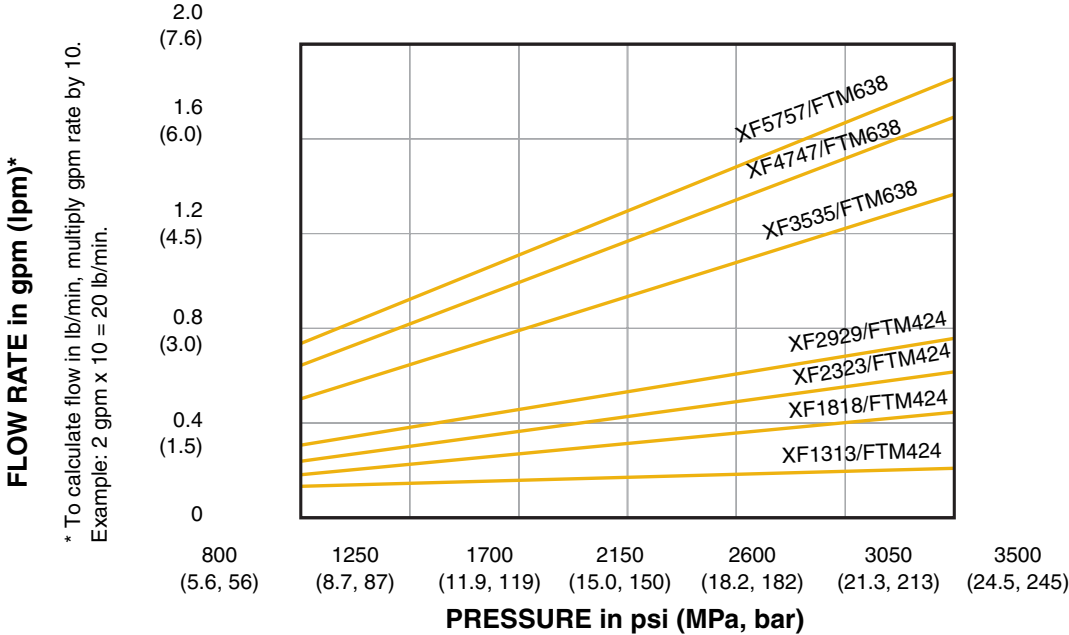

Use only these mix module/tip combinations.

Gun Part No., Series	Slip-Fit™ Polycarballoy™ Mix Module Part No., see page 46 for numbering code	Flat CeramTip™ Part No., see page 48 for numbering code
247050, A	XF1313	FTM317
247051, A	XF1313	FTM424
247057, A	XF1818	FTM317
247058, A	XF1818	FTM424
247061, A	XF2323	FTM424
247062, A	XF2323	FTM438
247063, A	XF2323	FTM624
247065, A	XF2929	FTM424
247066, A	XF2929	FTM438
247067, A	XF2929	FTM624
247073, A	XF3535	FTM438
247074, A	XF3535	FTM624
247075, A	XF3535	FTM638
247081, A	XF4747	FTM624
247082, A	XF4747	FTM638
247083, A	XF4747	FTM838
247089, A	XF5757	FTM638
247090, A	XF5757	FTM838
247091, A	XF5757	FTM848

Direct Impingement Flat Pattern Guns



 WARNING	
	<p>PERSONAL PROTECTIVE EQUIPMENT</p> <p>You must wear proper protective equipment when operating, servicing, or when in the operating area of the equipment to help protect you from serious injury, including eye injury, inhalation of toxic fumes, burns, and hearing loss. This equipment includes but is not limited to:</p> <ul style="list-style-type: none"> • Protective eyewear • Clothing and respirator as recommended by the fluid and solvent manufacturer • Gloves • Hearing protection.
	<p>TOXIC FLUID OR FUMES HAZARD</p> <p>Toxic fluids or fumes can cause serious injury or death if splashed in the eyes or on skin, inhaled, or swallowed.</p> <ul style="list-style-type: none"> • Read Material Safety Data Sheet (MSDS) to know the specific hazards of the fluids you are using. • Store hazardous fluid in approved containers, and dispose of it according to applicable guidelines.
	<p>INJECTION HAZARD</p> <p>High-pressure fluid from gun, hose leaks, or ruptured components will pierce skin. This may look like just a cut, but it is a serious injury that can result in amputation. Get immediate medical attention.</p> <ul style="list-style-type: none"> • Do not point the gun at anyone or at any part of the body. • Do not put your hand over the spray tip. • Do not stop or deflect leaks with your hand, body, glove, or rag. • Do not “blow back” fluid; this is not an air spray system. • Follow Pressure Relief Procedure, page 18, when you stop spraying and before cleaning, checking, or servicing equipment. • Use lowest possible pressure when flushing, priming, or troubleshooting. • Engage piston safety lock when not spraying. • Tighten all fluid connections before operating the equipment. • Check hoses, tubes, and couplings daily. Replace worn or damaged parts immediately. High pressure hose cannot be recoupled; replace the entire hose.
	<p>BURN HAZARD</p> <p>Equipment surfaces and fluid that’s heated can become very hot during operation. To avoid severe burns, do not touch hot fluid or equipment. Wait until equipment/fluid has cooled completely.</p>

WARNING
**FIRE AND EXPLOSION HAZARD**

Flammable fumes, such as solvent and paint fumes, in work area can ignite or explode. To help prevent fire and explosion:

- Use equipment only in well ventilated area.
- Eliminate all ignition sources, such as pilot lights, cigarettes, portable electric lamps, and plastic drop cloths (potential static arc).
- Do not plug or unplug power cords or turn lights on or off when flammable fumes are present.
- Keep the work area free of debris, including solvent, rags, and gasoline.
- Ground equipment and conductive objects. See **Grounding**, page 12.
- Hold gun firmly to side of grounded pail when triggering into pail.
- Use only grounded hoses.
- If there is static sparking or you feel a shock, **stop operation immediately**. Do not use equipment until you identify and correct the problem.

**EQUIPMENT MISUSE HAZARD**

Misuse can cause serious injury or death.

- For professional use only.
- Use equipment only for its intended purpose. Call your Graco distributor for information.
- Read manuals, warnings, tags, and labels before operating equipment. Follow instructions.
- Check equipment daily. Repair or replace worn or damaged parts immediately.
- Do not alter or modify equipment. Use only Graco parts and accessories.
- Do not exceed the maximum working pressure or temperature rating of the lowest rated system component. See **Technical Data** in all equipment manuals.
- Use fluids and solvents that are compatible with equipment wetted parts. See **Technical Data** in all equipment manuals. Read fluid and solvent manufacturer's warnings.
- Route hoses and cables away from traffic areas, sharp edges, moving parts, and hot surfaces.
- Do not use hoses to pull equipment.
- Comply with all applicable safety regulations.

**PRESSURIZED ALUMINUM PARTS HAZARD**

Do not use 1,1,1-trichloroethane, methylene chloride, other halogenated hydrocarbon solvents or fluids containing such solvents in pressurized aluminum equipment. Such use can cause serious chemical reaction and equipment rupture, and result in death, serious injury, and property damage.

Overall View

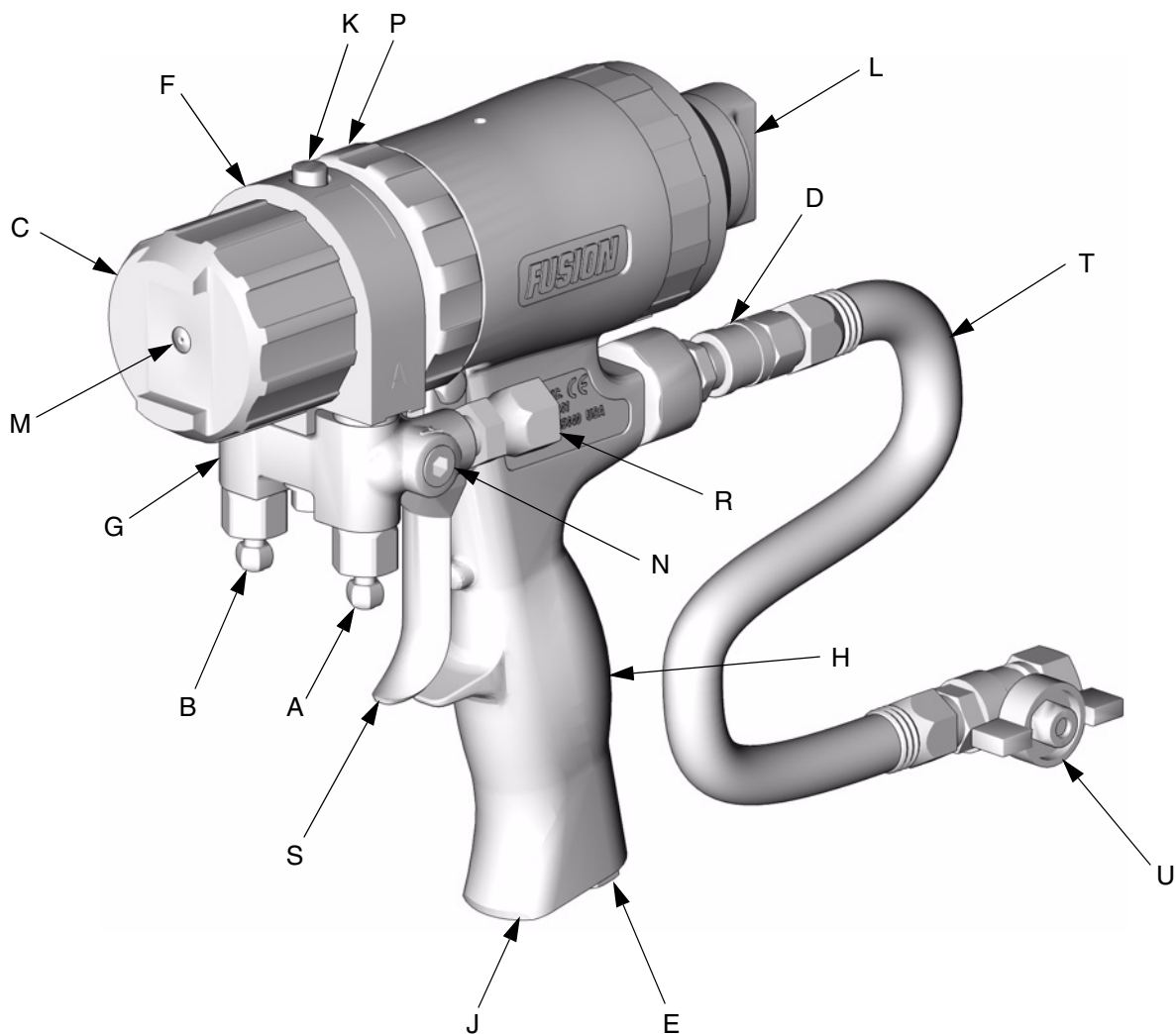

TI3840a-1

Key:

- | | | | |
|---|----------------------------|---|--------------------------------------|
| A | A Side Fluid Valve (ISO) | K | Cleanoff Air Valve |
| B | B Side Fluid Valve (RESIN) | L | Piston Safety Lock |
| C | Air Cap | M | CeramTip (behind air cap) |
| D | Air Line Quick Coupler | N | Optional Fluid Inlets (A Side Shown) |
| E | Muffler | P | Lock Ring |
| F | Fluid Housing | R | Fluid Inlet Swivels (A Side Shown) |
| G | Gun Fluid Manifold | S | Trigger |
| H | Handle | T | Gun Air Whip Hose |
| J | Optional Air Inlet | U | Air Valve |

Isocyanate Hazard

WARNING



Read Material Safety Data Sheet (MSDS) to know the specific hazards of isocyanates. Use equipment in a well-ventilated area. Wear respirator, gloves, and protective clothing when using isocyanates.

Keep A and B Components Separate

CAUTION

To prevent cross-contamination of the gun's wetted parts, do not interchange A component (isocyanate) and B component (resin) parts. The gun is shipped with the A side on the left. The fluid manifold, fluid housing, check valve cartridge, and mix module are marked on the A side.

Grounding

WARNING



Read warnings, page 10.

Check your local electrical code and proportioner manual for detailed grounding instructions.

Ground the spray gun through connection to a Graco-approved grounded fluid supply hose.

Piston Safety Lock

Engage piston safety lock whenever you stop spraying, to avoid accidental triggering.

WARNING



Read warnings, page 9.

To engage piston safety lock: push knob in and turn clockwise. When engaged, piston safety lock allows some purge rod movement but shuts off fluid flow and gun cannot spray.



TI3850a

To disengage piston safety lock: push knob in and turn counterclockwise until it pops out.

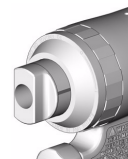

TI3849a

Loss of Air Pressure

In event of loss of air pressure while gun is triggered, gun will continue to spray. To shut off gun, do one of the following:

- Push hard or hit end of safety lock, to engage piston safety lock.

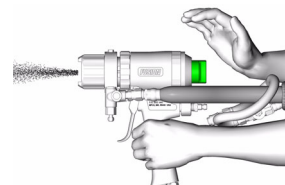

TI4022a

- Close fluid valves A and B.

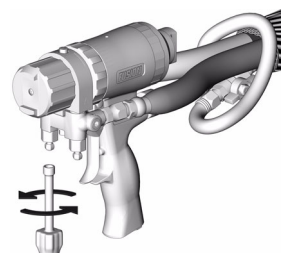

TI3837a

Setup

- 1.** Close fluid valves A and B.

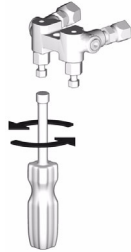

TI2411A

- 2.** Connect A (ISO) and B (RESIN) fluid hoses to fluid manifold.

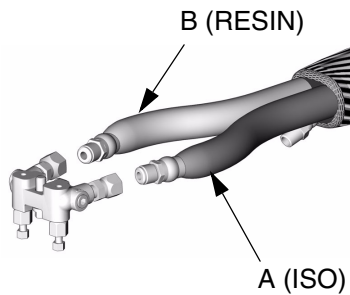

TI2417A

- 3.** Engage piston safety lock, page 12.

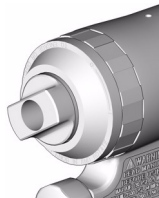

TI3850a

- 4.** Connect gun air whip hose (T) and air valve (U) to main air hose. Attach fluid manifold (G) to gun.

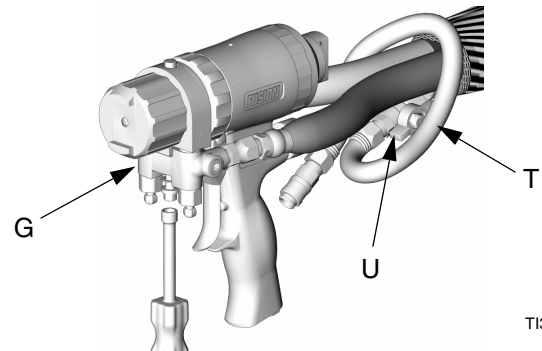

TI3830a

 To change position of fluid manifold or use optional fluid inlets, see pages 19 and 20.

- 5.** Connect air line to quick coupler (D). Turn on air. Open air valve (U). Air should flow from air cap around CeramTip (M). Open cleanoff air valve (K) about 1/4 to 1/2 turn, then adjust air flow as required.

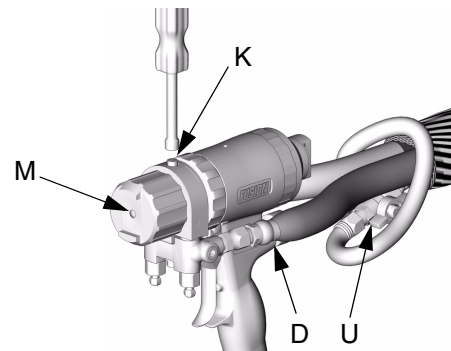

TI3839a

 To use optional air inlet, see page 20.

- 6.** Adjust purge rod, page 15.

- 7.** Turn on proportioner.

- 8.** Open B (RESIN) fluid valve (about three half turns). Then open A (ISO) fluid valve.

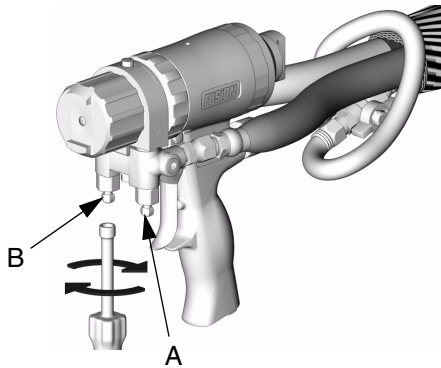

T13838a

- 9.** Disengage piston safety lock, page 12.



T13849a

- 10.** Test spray onto cardboard. Adjust pressure and temperature to get desired results.

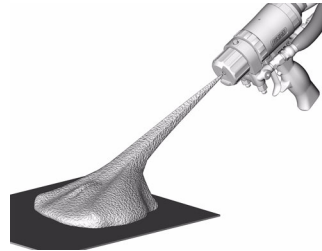

T13861a

- 11.** Apply layer of lubricant over front of gun and lock ring, or use gun cover to prevent overspray buildup and ease disassembly. See page 51 to order Fusion Gun Lubricant and gun cover.

- 12.** Gun is ready to spray.

Adjust Purge Rod

1. Engage piston safety lock, page 12.



T13850a

2. Close fluid valves A and B.

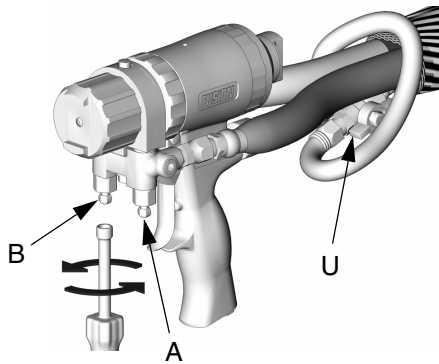

T13837a

3. Connect air supply and open air valve (U).

4. Adjust purge rod with nut driver clockwise until it just touches CeramTip, then back off 1/8-1/4 turn.

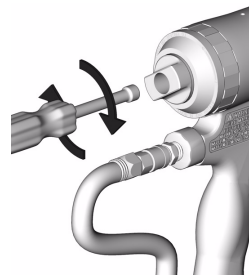

T13829a

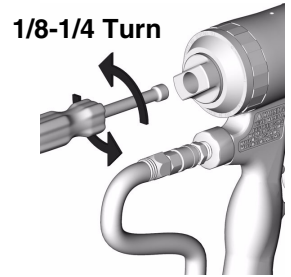

T13828a

 Be sure to back out purge rod 1-2 turns before changing CeramTips or mix modules. Readjust purge rod after replacing CeramTips or mix modules.

Adjust Flat CeramTip

⚠ WARNING



Read warnings, page 9.

1. Engage piston safety lock, page 12.



TI3850a

2. Close fluid valves A and B.

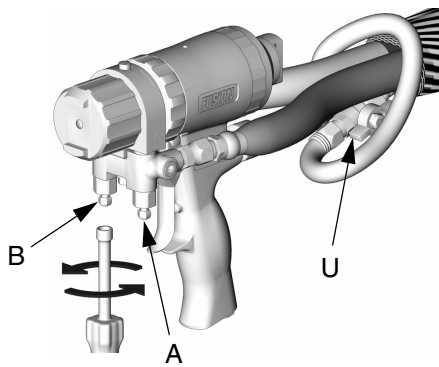

TI3837a

3. Remove air cap (9).

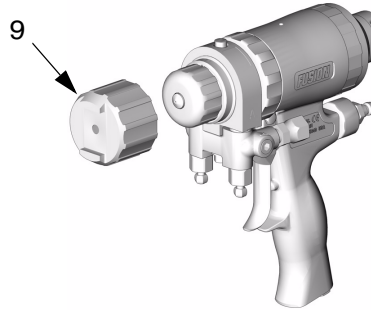

TI3854a

4. Using nut driver, position CeramTip as desired.

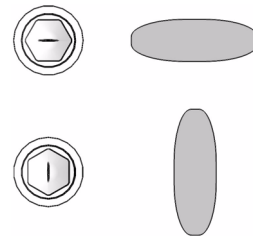

TI3867a

5. Reassemble air cap (9) fingertight.

Shutdown

Daily Shutdown

Follow **Pressure Relief Procedure**, page 18.

Shutdown for More than a Day

- 1.** Flush Gun, page 22.
- 2.** Follow **Pressure Relief Procedure**, page 18.

Pressure Relief Procedure

⚠ WARNING



Read warnings, page 9. Relieve pressure before cleaning or repairing gun.

1. Engage piston safety lock, page 12.

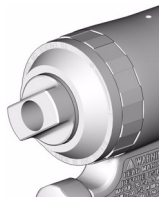

T13850a

 Air supply is required for gun actuation. Do not disconnect gun air supply until fluid pressure is relieved.

2. Close fluid valves A and B. Leave air valve (U) open.

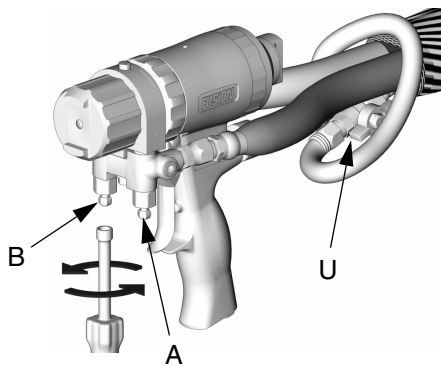

T13837a

3. Disengage piston safety lock, page 12.

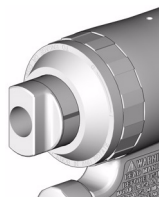

T13849a

4. Trigger gun onto cardboard or into waste container to relieve pressure.



T14243a

5. Engage piston safety lock, page 12.

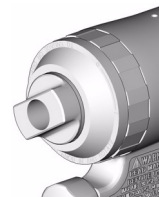

T13850a

⚠ WARNING



If fluid in the hose and proportioner is still under pressure, follow the Pressure Relief Procedure in the proportioner manual.

To relieve pressure in the hose after the gun is removed, place the fluid manifold over containers, facing away from you. Very carefully open the fluid valves. Under high pressure, fluid will spray sideways from the fluid ports.

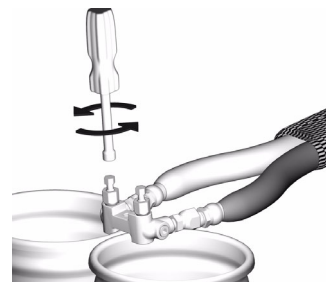

T12484A

Optional Configurations

Optional Fluid Manifold Position

Fluid manifold is mounted to bottom of gun, with A side on left, viewed from operator's position at back of gun. If desired, manifold may be moved to top of gun. Doing this will reposition A side parts (fluid inlet, check valve, and fluid housing A side) to right.

CAUTION
To prevent cross-contamination of gun's wetted parts, do not interchange A component (isocyanate) and B component (resin) parts.

1. Follow **Pressure Relief Procedure**, page 18.

2. Disconnect air (D) and remove fluid manifold (G).

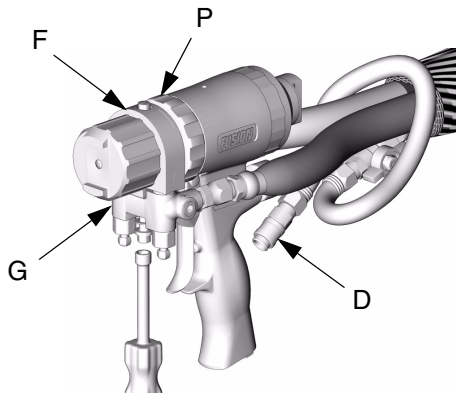

T13837a

- 3.** Unscrew lock ring (P) until front end of gun is loose.
- 4.** Rotate fluid housing (F) 180° and retighten lock ring very securely.
- 5.** Attach fluid manifold. Connect air. Return gun to service.

Optional Hose Position

Fluid inlet swivels and air quick disconnect fitting point to rear. If desired, these positions can be changed so hoses travel downward.

Fluid Hoses

CAUTION
To prevent cross-contamination of gun's wetted parts, do not interchange A component (ISO) and B component (RESIN) parts.

1. Follow **Pressure Relief Procedure**, page 18. Also relieve system pressure, see proportioner manual.

2. Disconnect air (D) and remove fluid manifold (G).

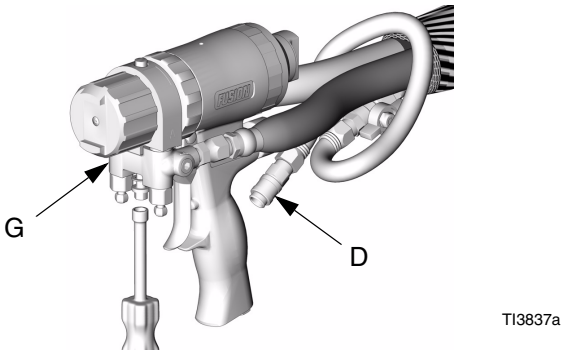

3. Disconnect fluid hoses from inlet swivels (A, B). Remove swivels. Remove plugs from optional inlets (N).

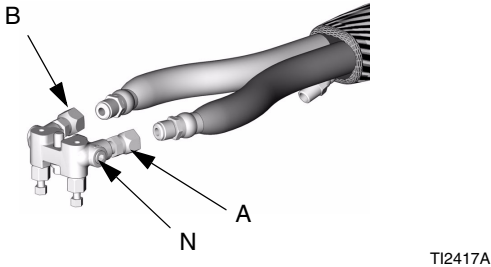

4. Apply thread sealant to plugs (W), elbows (V), and male threads of swivels (A, B). Install elbows (V) in optional inlets (N), facing down. Install swivels (A, B) in elbows. Be sure to install A swivel (smaller) in A side. Install plugs (W) where swivels had been. Torque all parts to 235-245 in-lb (26.6-27.7 N•m).

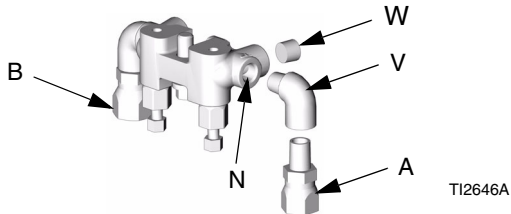

5. Connect A and B hoses to A and B swivels.

Air Hose

1. Remove fitting (D) and plug (J). Reverse positions. Apply thread sealant and torque to 125-135 in-lb (14-15 N•m).

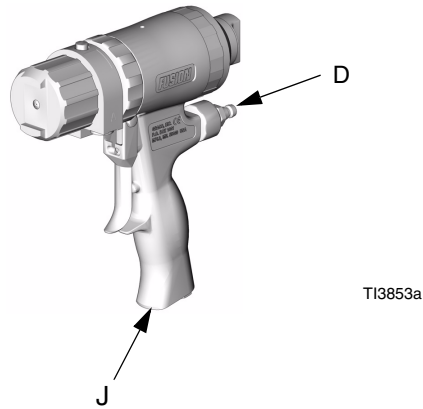

2. Attach fluid manifold. Connect air. Return gun to service.

Maintenance

Supplied Tool Kit

- Hex Nut Driver; 5/16
- Screwdriver; 1/8 blade
- CeramTip Drill Bit; various sizes depending on CeramTip size. See TABLE 2, page 25.
- Mix Module Drill Bit; various sizes depending on port size. See TABLE 1, page 24.

- 117661 Pin Vise; dual reversible chucks

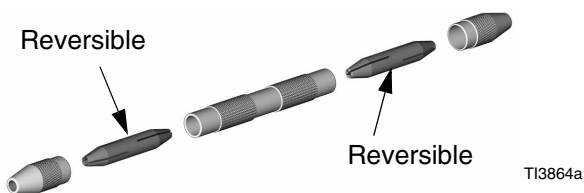

- 15B817 Flush Manifold

Keep Gun Clean

Keep gun clean with accessory gun cover, page 51.

Applying a light coat of lubricant will make cleaning easier. Lubricate threads and outside of lock ring (11) to ease disassembly. Use Fusion Gun Lubricant, page 51.

As Needed

- 1. Clean Outside of Gun**, page 22.
- 2. Clean CeramTip**, page 25, a minimum of once a day.
- 3. Clean Air Cap**, page 22.

- 4. Clean Muffler**, page 22.

- 5. Clean Fluid Manifold**, page 22.

- 6. Clean Slip-Fit Polycarbally Mix Module**, page 23.

Daily

Follow **Shutdown**, page 17.

Weekly to Monthly

- 1. Clean Purge Rod**, page 26.
- 2. Clean Check Valves**, page 40. Check o-rings and screens.
- 3. Check that piston safety lock threaded connection is tight**, page 43.

Flush Gun

If it is necessary to flush gun, use following procedure.

 WARNING  
Read warnings, page 10.

- 1.** Follow **Pressure Relief Procedure**, page 18.
- 2.** Flush with a compatible solvent.
- 3.** Flush into a grounded metal pail, holding a metal part of fluid manifold firmly to side of pail. Use the lowest possible fluid pressure when flushing.
- 4.** Follow **Pressure Relief Procedure**, page 18.



Flush Manifold 15B817 is included with gun. Install in place of fluid manifold and connect solvent line to flush gun.

Solvent Flush Kits 248139 and 248229 are available as accessories. See page 51.

Clean Outside of Gun

Wipe off outside of gun with compatible solvent.

CAUTION

Use N Methyl Pyrrolidone (NMP), Dynasolve CU-6, Dzolv, or equivalent to soften cured material when cleaning the outside of gun. **Do not use as flushing solvents.**

Clean Air Cap

Soak air cap in compatible solvent. If necessary, clean gently with stiff brush.

Clean Muffler

A partially plugged muffler will slow gun actuation. Remove and clean muffler with compatible solvent.

Clean Fluid Manifold

Clean fluid manifold sealing faces with compatible solvent and a brush whenever removed from gun. Be sure to clean the two fluid ports (X) in the top mating surface. Do not damage the flat sealing surfaces. Cover with Fusion Lubricant (page 51) if left exposed, to seal out moisture.

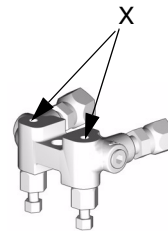

TI2411-1

Clean Slip-Fit Polycarballyoy Mix Module

1. Follow **Pressure Relief Procedure**, page 18.
2. **Flush Gun**, page 22.
3. Remove mix module, page 37.

CAUTION

To avoid damaging mix module, do not force drill bits when cleaning impingement ports. Some ports are offset or angled.

4. See FIG. 1 and FIG. 2. Clean mix module impingement ports (IP) with appropriate size drill (supplied). See TABLE 1, page 24. Also see identification chart under **Drill Bit Kits**, page 49.



Component B (RES) impingement ports, at rear of mix module, are angled toward front of gun. See FIG. 2.

Some mix modules have counterbored holes (CB) and require two drill sizes to clean impingement ports completely. See FIG. 3 and TABLE 1.

5. Reassemble, page 37.

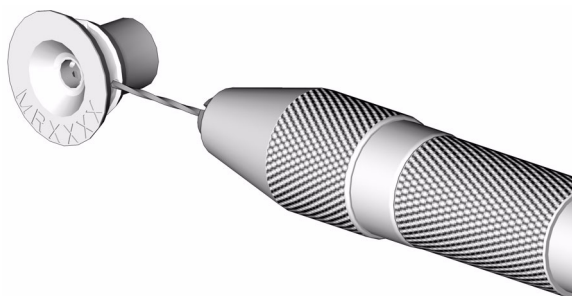

T13863a

FIG. 1. Cleaning Component A (ISO) Ports



T13862a

FIG. 2. Cleaning Component B (Resin) Ports

NOTE: View is not to scale.

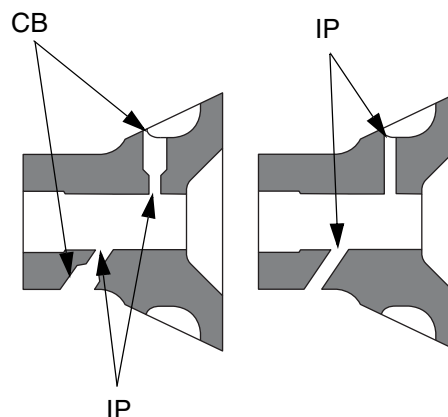

Mix Modules
XF1313,
XF1818,
MF1818

All Other
Mix Modules

T13876a

FIG. 3. Mix Module Cross Section

Table 1: Impingement Port Cleanout Drill Sizes

Standard Round Slip-Fit Polycarbally Mix Modules					
Mix Module Part No.	No. of Impingement Ports	Impingement Port Drill		Counterbore Drill	
		Drill Size (nominal)	Drill Diameter in. (mm)	Drill Size (nominal)	Drill Diameter in. (mm)
MR3535	2	#73	.0240 (0.61)	N/A	N/A
MR4747	2	#67	.0320 (0.81)	N/A	N/A
MR5757	3	#67	.0320 (0.81)	N/A	N/A
MR6666	4	#67	.0320 (0.81)	N/A	N/A
MR8282	4	#60	.0400 (1.02)	N/A	N/A
MR9494	4	#56	.0465 (1.18)	N/A	N/A
Standard Flat Slip-Fit Polycarbally Mix Modules					
Mix Module Part No.	No. of Impingement Ports	Impingement Port Drill		Counterbore Drill	
		Drill Size (nominal)	Drill Diameter in. (mm)	Drill Size (nominal)	Drill Diameter in. (mm)
MF1818	1	#77	.0180 (0.46)	#67	.0320 (0.81)
MF2929	1	#69	.0292 (0.74)	N/A	N/A
MF3535	2	#73	.0240 (0.61)	N/A	N/A
MF4747	2	#67	.0320 (0.81)	N/A	N/A
MF5757	3	#67	.0320 (0.81)	N/A	N/A
Direct Impingement Round Slip-Fit Polycarbally Mix Modules					
Mix Module Part No.	No. of Impingement Ports	Impingement Port Drill		Counterbore Drill	
		Drill Size (nominal)	Drill Diameter in. (mm)	Drill Size (nominal)	Drill Diameter in. (mm)
XR2323	1	#74	.0230 (0.57)	N/A	N/A
XR2929	1	#69	.0292 (0.74)	N/A	N/A
XR3535	2	#73	.0240 (0.61)	N/A	N/A
XR4747	2	#67	.0320 (0.81)	N/A	N/A
XR5757	3	#67	.0320 (0.81)	N/A	N/A
Direct Impingement Flat Slip-Fit Polycarbally Mix Modules					
Mix Module Part No.	No. of Impingement Ports	Impingement Port Drill		Counterbore Drill	
		Drill Size (nominal)	Drill Diameter in. (mm)	Drill Size (nominal)	Drill Diameter in. (mm)
XF1313	1	#81	.0130 (0.33)	#67	.0320 (0.81)
XF1818	1	#77	.0180 (0.46)	#67	.0320 (0.81)
XF2323	1	#74	.0230 (0.57)	N/A	N/A
XF2929	1	#69	.0292 (0.74)	N/A	N/A
XF3535	2	#73	.0240 (0.61)	N/A	N/A
XF4747	2	#67	.0320 (0.81)	N/A	N/A
XF5757	3	#67	.0320 (0.81)	N/A	N/A

Clean CeramTip

Round CeramTip

1. Follow **Pressure Relief Procedure**, page 18.
2. Remove CeramTip, page 33.
3. Clean CeramTip hole with appropriate size drill (supplied). See TABLE 2. Also see identification chart under **Drill Bit Kits**, page 49.

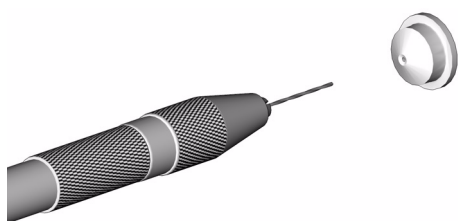

TI3868a

Table 2: Cleanout Drill Sizes for Round CeramTips

Round CeramTip Kit Part No.	Drill Size (nominal)	Cleanout Drill Diameter in. (mm)
RTM024	#73	.0240 (0.61)
RTM030	#67	.0320 (0.81)
RTM040	#60	.0400 (1.02)
RTM055	#54	.0550 (1.40)
RTM070	#50	.0700 (1.78)
RTM080	2.0 mm	.0787 (2.00)
RTM090	#43	.0890 (2.26)
RTM100	#39	.0995 (2.53)
RTM110	7/64	0.1094 (2.78)

4. Clean CeramTip internal dome with 15D234 Tip Cleanout Tool, page 51.

Flat CeramTip

1. Follow **Pressure Relief Procedure**, page 18.
2. Remove CeramTip, page 33.
3. Soak CeramTip in compatible solvent. Clean gently with 15D234 Tip Cleanout Tool, page 51, to fit tip configuration.
4. Reposition CeramTip horizontally or vertically.

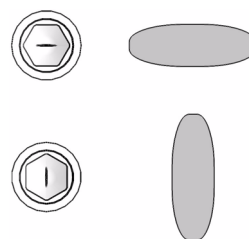

TI3867a

External Quick Cleaning Method

1. Engage piston safety lock, page 12.

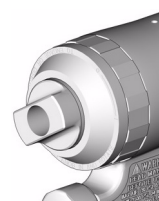

TI3850a

2. Close fluid valves A and B.

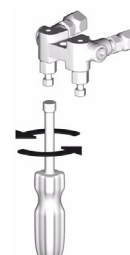

TI2411A

3. Clean *CeramTip* hole (E) with appropriate size drill (supplied). See TABLE 2. Also see identification chart under **Drill Bit Kits**, page 49.



Clean *flat tip slit* (H) with tip cleanout tool 15D234 (page 51).

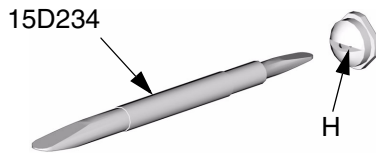

4. Open B (RESIN) fluid valve (about three half turns). Then open A (ISO) fluid valve.

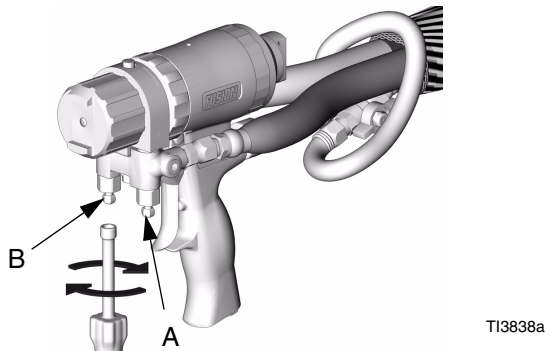

5. Disengage piston safety lock, page 12.

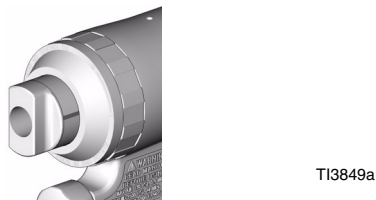

Stuck Purge Rod

If purge rod (31) is stuck and cannot actuate, use this procedure to free it.

1. Engage piston safety lock, page 12.

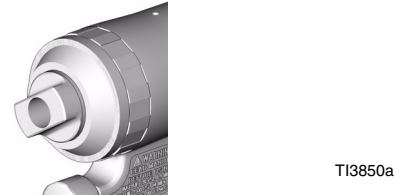

2. Trigger gun and hold. Turn purge rod counterclockwise.

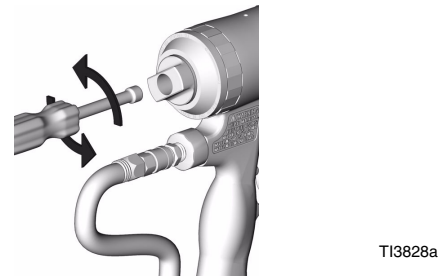

3. Adjust Purge Rod, page 15.

Clean Purge Rod

Clean purge rod (31) weekly or monthly.

1. Follow **Pressure Relief Procedure**, page 18.
2. **Flush Gun**, page 22.

3. Disconnect air (D) and remove fluid manifold (G).

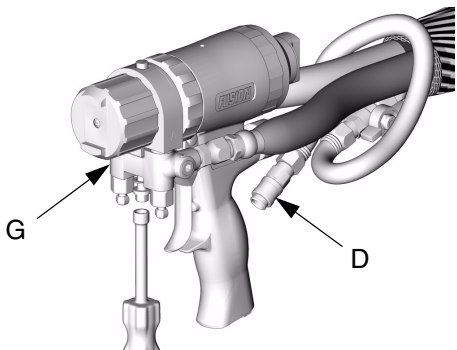

TI3837a

4. Disassemble Front End, page 34.
5. Clean exposed portion of purge rod (31). Apply Fusion Gun Lubricant, page 51.

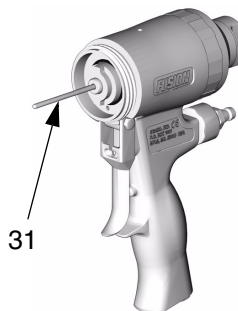

TI3873a

6. Reassemble Front End, page 35.
7. Adjust Purge Rod, page 15.
8. Attach fluid manifold. Connect air. Return gun to service.

Adjust Front Rod Seal

If fluid misting occurs from tip when gun is not triggered, use following procedure to temporarily stop leakage until parts are replaced.

1. Follow **Pressure Relief Procedure**, page 18.
2. Back out purge rod 1-2 turns with nut driver.

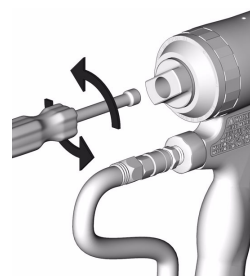

TI3828a

3. Remove air cap (9).

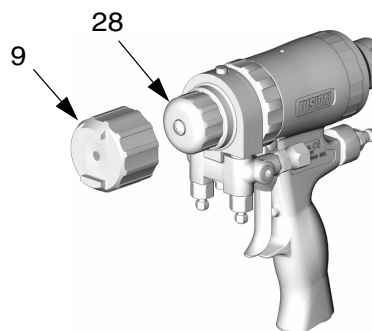

TI3854a

4. Trigger gun and hold. Tighten retainer (28) an additional notch, to tighten front seal (46) onto purge rod (31).
5. Detrigger gun. Reassemble air cap (9) fingertight.
6. **Adjust Purge Rod**, page 15.

Adjust Rear Rod Seal

1. Follow **Pressure Relief Procedure**, page 18.
2. **Flush Gun**, page 22.
3. Remove fluid manifold (G). Leave air connected.

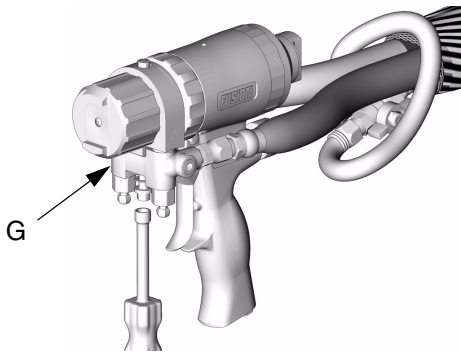

TI3852a

4. **Disassemble Front End**, page 34.
5. Assemble fluid housing (7) backwards onto lubricated purge rod (31). Adjust rear rod seal nut (23) with nut driver until drag is felt when sliding on rod.

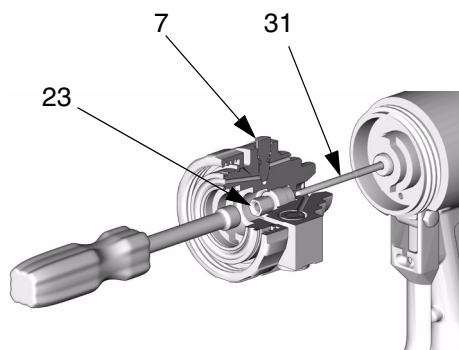

TI3831a

6. Remove fluid housing (7) from rod (31).
7. **Reassemble Front End**, page 35.
8. **Adjust Purge Rod**, page 15.
9. Attach fluid manifold. Return gun to service.

Troubleshooting

1. Follow **Pressure Relief Procedure**, page 18, before checking or repairing gun.
2. Check all possible problems and causes before disassembling gun.

CAUTION
To prevent cross-contamination of the gun's wetted parts, do not interchange A component (isocyanate) and B component (resin) parts.

PROBLEM	CAUSE	SOLUTION
Gun does not fully actuate when triggered.	Piston safety lock engaged.	Disengage piston safety lock, page 12.
	Plugged muffler (22).	Clean, page 22.
	Damaged air valve o-rings (24).	Replace, page 43.
Fluid does not spray when gun is fully actuated.	Closed fluid valves (12b).	Open.
	Plugged impingement ports.	Clean, page 23.
	Plugged check valves (36).	Clean, page 40.
Gun actuates slowly or with delayed action.	Plugged muffler (22).	Clean, page 22.
	Damaged piston o-rings (16, 19).	Replace, page 41.
	Dirty air valve, or damaged o-rings (24).	Clean air valve or replace o-rings, page 43.
	Mix module nut (25) too tight.	Loosen nut, then retighten, page 36.
	Incorrect purge rod adjustment.	Adjust Purge Rod , page 15.
	Loose lock ring (11).	Tighten, use tool if necessary. Adjust Purge Rod , page 15.
Purge rod will not actuate.	No air pressure.	Connect air supply.
	Low air pressure.	Set air pressure above 80 psi (0.56 MPa, 5.6 bar).
	Buildup on purge rod (31).	See Clean Purge Rod , page 26.

PROBLEM	CAUSE	SOLUTION
Loss of round pattern.	Dirty CeramTip (40).	Clean, page 25.
	Too little cleanoff air.	Readjust, page 13.
Loss of flat pattern.	Plugged CeramTip (40).	Clean in compatible solvent.
	Worn CeramTip (40).	Replace, page 33.
Pressure imbalance.	Plugged impingement ports.	Clean, page 23. Reinstall mix module, page 37.
	Plugged check valves (36).	Clean, page 40.
	Viscosities not equal.	Adjust temperature to compensate.
Fluid mist from CeramTip.	Worn mix module (39).	Replace, page 37.
	Worn front rod seal (46).	Replace, page 39.
Excessive overspray.	Too much cleanoff air.	Reduce, page 13.
Rapid buildup of material on air cap.	Too little cleanoff air.	Increase, page 13.
Fluid does not shut off when fluid valves are closed.	Damaged fluid valves (12b).	Replace.
Reduced cleanoff air.	Plugged air passage.	Open.
Air leakage around fluid housing.	Damaged or missing o-ring (20).	Replace.
Air leakage from piston safety lock.	Damaged or missing o-rings (18).	Replace, page 41.
Burst of air from muffler when gun is triggered.	Normal.	No action required.
Steady air leakage from muffler.	Damaged air valve o-rings (24)	Replace, page 43.
	Damaged piston o-rings (16, 19).	Replace, page 41.
Air leakage from front air valve.	Damaged air valve o-rings (24).	Replace, page 43.
Component B (resin) leak from fluid housing.	Worn rear rod seal.	Adjust Rear Rod Seal , page 28.

Theory of Operation

Gun Triggered (Fluid Spraying)

Purge rod (31) moves back, opening impingement ports (IP). Components A and B combine in mix module (39). Fluid sprays from CeramTip (40).

Cleanoff air flows whether gun is triggered or detri-gered. See page 13 to adjust.

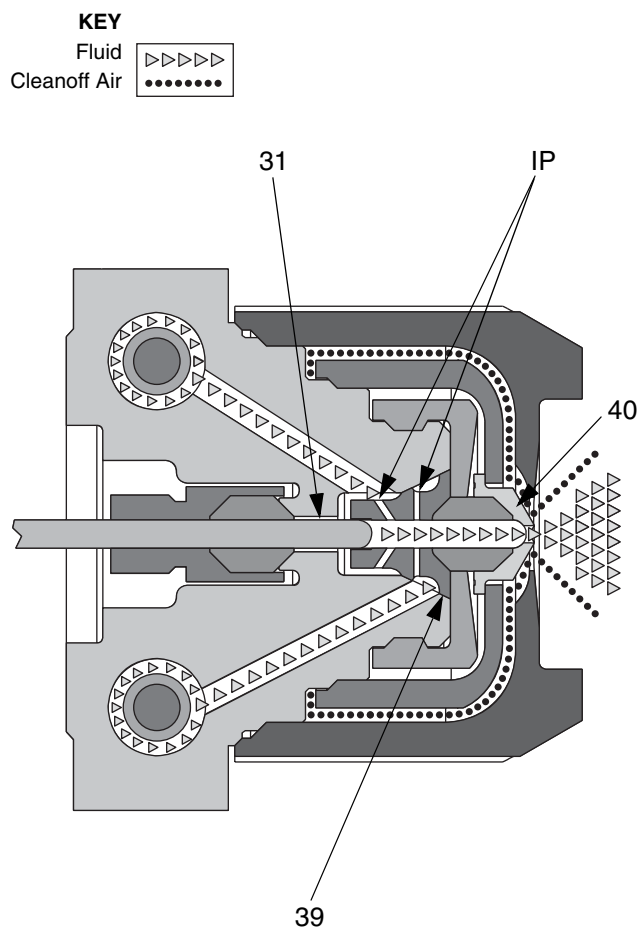

TI3882a

Gun Detriggered (Mechanical Purg- ing)

Purge rod (31) moves forward, closing impingement ports (IP) and shutting off fluid flow. Rod pushes through mix module (39) and bottoms on CeramTip (40), forcing out excess fluid and restoring proper orifice diameter.

Cleanoff air flows whether gun is triggered or detri-gered. See page 13 to adjust.

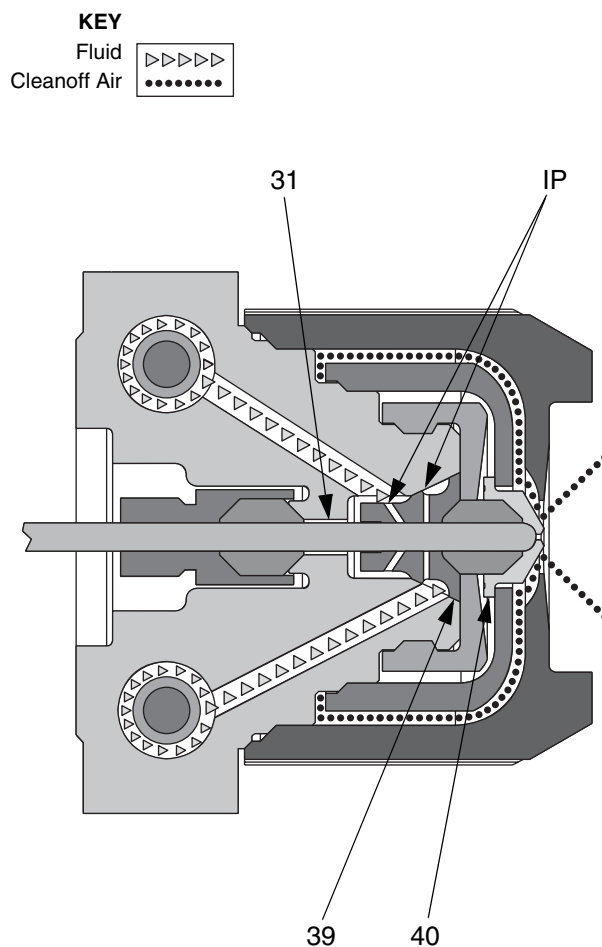

TI3881a

Cutaway View

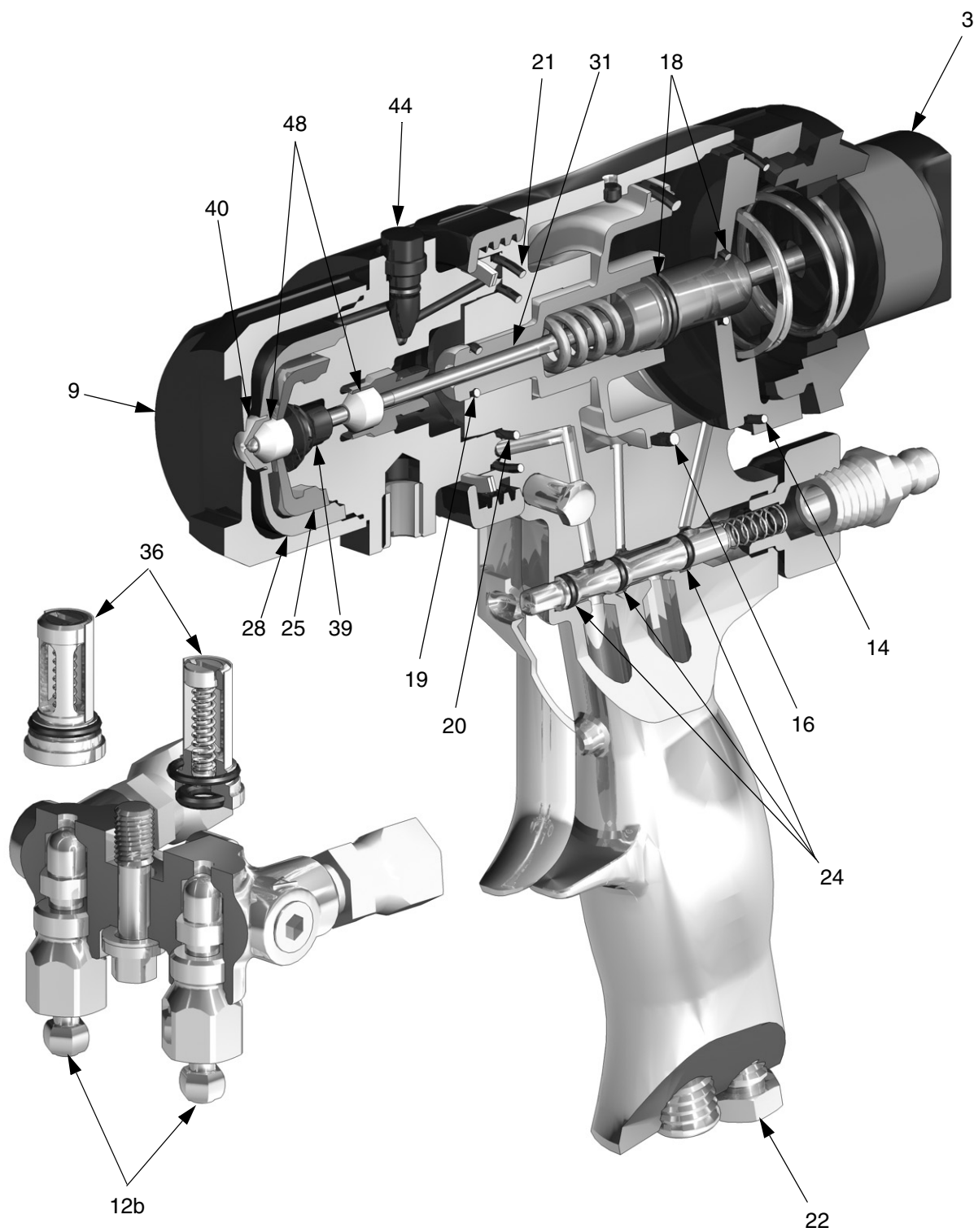

Repair

Tools Required

Tools needed for complete gun repair:

- adjustable wrench
- flat head screwdriver (included)
- channel-lock pliers (2 pair)
- 5/16 hex nut driver (included)
- o-ring pick
- medium-strength Loctite®
- solvent or alcohol

Lubrication

Liberalily lubricate all o-rings, seals, and threads with Fusion Gun Lubricant, page 51. Lubricate threads and outside of lock ring (11).

Replace CeramTip

1. Follow **Pressure Relief Procedure**, page 18.
2. Remove fluid manifold (G). Leave air connected.

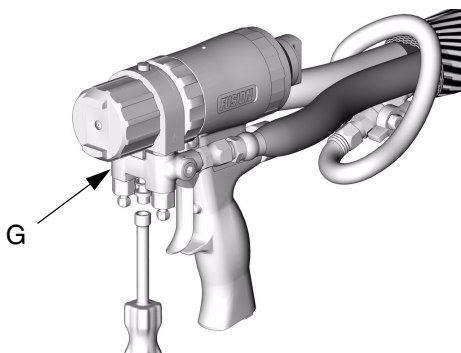

TI3852a

3. Back out purge rod 1-2 turns with nut driver.

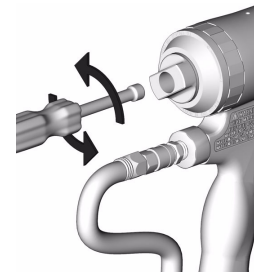

TI3828a

4. Remove air cap (9), retainer (28), and CeramTip (40).

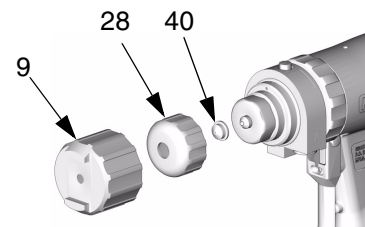

TI3843a



If CeramTip is stuck, trigger and dettrigger gun once to release it.

5. Install new CeramTip (40). Lubricate all threads. Install retainer (28) fingertight, plus 1 notch. Install air cap (9) fingertight.
6. **Adjust Purge Rod**, page 15.
7. Attach fluid manifold. Return gun to service.

Disassemble Front End

WARNING



Read warnings, page 9. Proper attachment of front end is critical. Do not operate gun if front end is loose or lock ring is not snug against handle.

CAUTION

If lock ring (11) is stuck due to material buildup, do not force it by turning entire front end. Locating tabs (Z) may break off. Soak front of gun in solvent to soften cured material and free lock ring.

CAUTION

To prevent damage to purge rod (31), always pull front end straight off handle (1).

1. Follow **Pressure Relief Procedure**, page 18.
2. **Flush Gun**, page 22.
3. Back out purge rod 1-2 turns with nut driver.

6. Unscrew lock ring (11) to remove front end and mix module. Pull front end straight off handle (1).

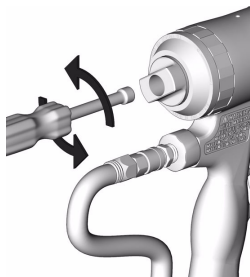

TI3828a

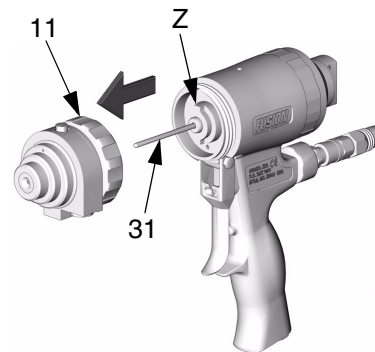

TI3865b

4. Remove air cap (9), retainer (28), and CeramTip (40).

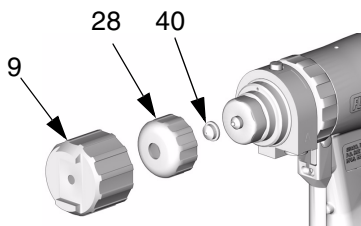

TI3843a

5. Remove mix module nut (25), using air cap (9) backwards, or a wrench. Remove front seal (46).

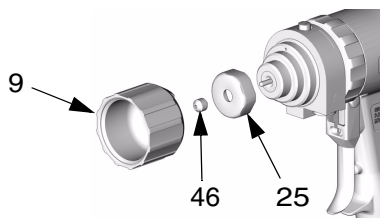

TI3843a

Reassemble Front End

1. Check that o-rings (20, 21) are in position. Liberally lubricate o-rings, threads of lock ring (11) and handle (1), and outside of lock ring.

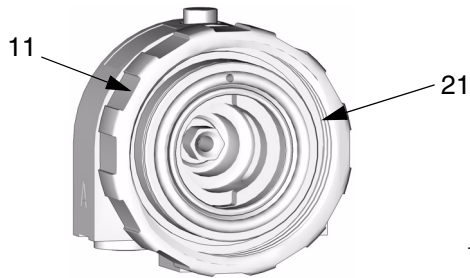

TI3871a

2. Orient front end as required for desired fluid manifold mounting (bottom mounting shown). Align slots (Y) to engage tabs (Z).

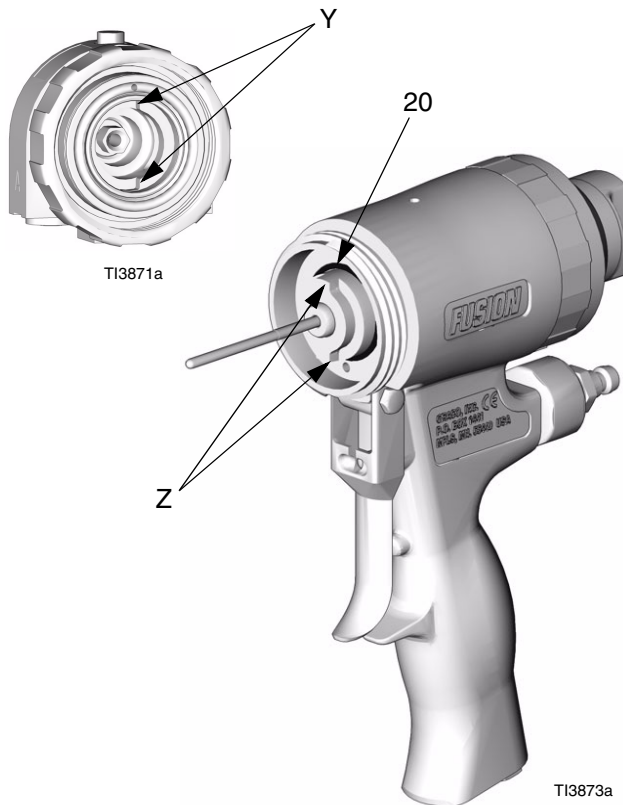

TI3871a

TI3873a

CAUTION
To prevent damage to purge rod (31), always slide front end straight onto purge rod.

3. Carefully slide front end straight onto purge rod (31). Screw lock ring (11) onto handle (1) as far as possible by hand. Push on front end to ensure it is properly seated. Continue screwing lock ring onto handle until tightened very securely. When properly assembled, lock ring is snug against handle.

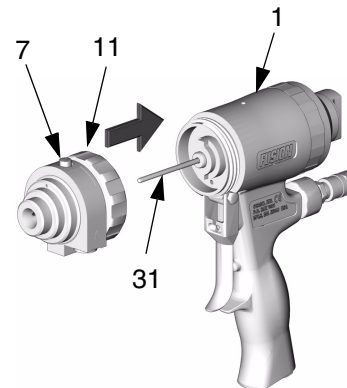

TI3866a

4. Push mix module (39) onto rod (31) as far as possible.

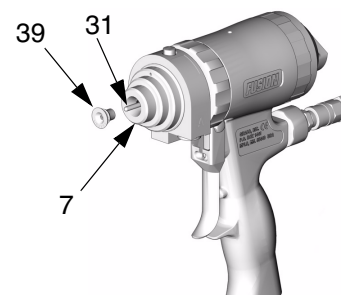

TI3845a

CAUTION

Do not overtighten mix module nut (25). Overtightening can deform impingement holes and cause slow gun actuation.

- 5.** Lubricate all threads and reassemble mix module nut (25) **fingertight**. Tighten additional 1/12 turn with air cap (9) or wrench. Install front seal (46) on rod (31).

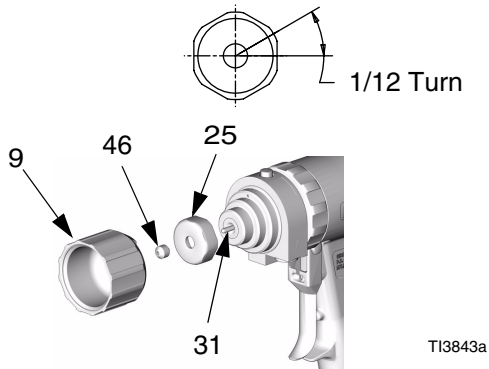

- 6.** Reinstall CeramTip (40). Lubricate all threads. Install retainer (28) fingertight, plus 1 notch. Install air cap (9) fingertight.

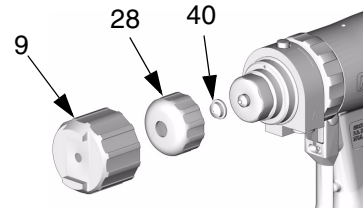

- 7.** Adjust Purge Rod, page 15.

Slip-Fit Polycarballoy Mix Module

See page 46 for available Slip-Fit Polycarballoy Mix Module sizes.

1. Follow **Pressure Relief Procedure**, page 18.
2. **Flush Gun**, page 22.
3. Remove fluid manifold (G). Leave air connected.

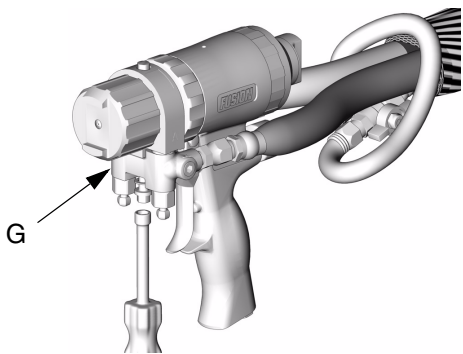

TI3852a

4. Remove air cap (9), retainer (28), and CeramTip (40).

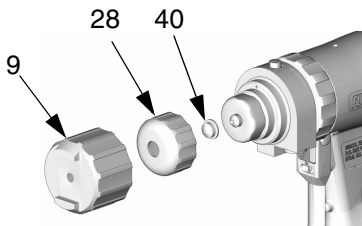

TI3843a

5. Remove mix module nut (25), using air cap (9) backwards, or a wrench. Remove front seal (46).

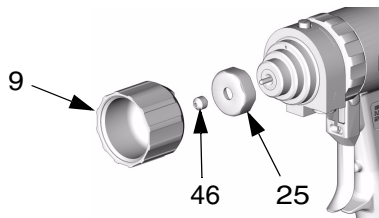

TI3843a

6. Disengage piston safety lock, page 12. Trigger and dettrigger gun once to release mix module (39) from fluid housing (7). Remove mix module. Engage piston safety lock.

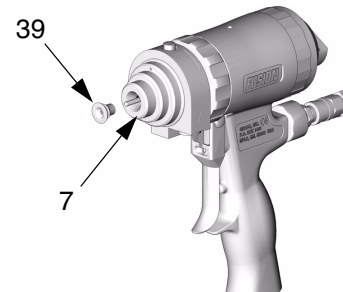

TI3845a

If mix module (39) does not protrude from fluid housing (7), slightly loosen then retighten lock ring (11), to allow gripping of edge for removal.

7. Push mix module (39) onto rod (31) as far as possible.

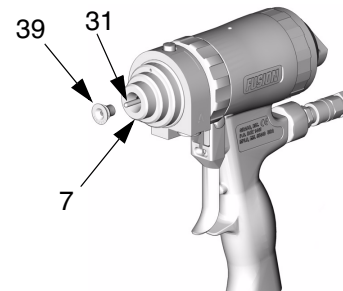

TI3845a

CAUTION

Do not overtighten mix module nut (25). Overtightening can deform impingement holes and cause slow gun actuation.

- 8.** Lubricate all threads and reassemble mix module nut (25) **fingertight**. Tighten additional 1/12 turn with air cap (9) or wrench. Install front seal (46) on rod (31).

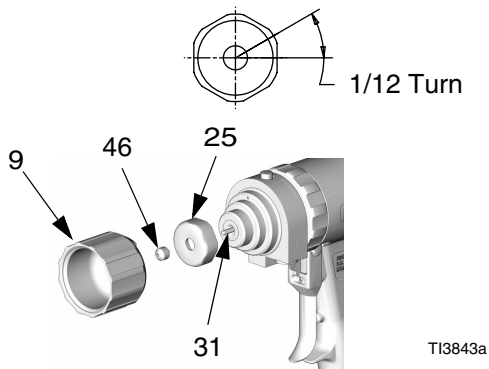

- 9.** Reinstall CeramTip (40). Lubricate all threads. Install retainer (28) fingertight, plus 1 notch. Install air cap (9) fingertight.

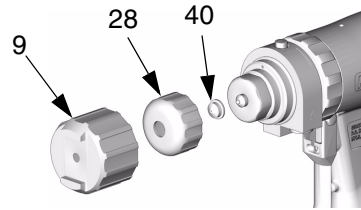

T13843a

- 10.** Adjust Purge Rod, page 15.

- 11.** Attach fluid manifold. Return gun to service.

Rear Rod Seal

1. Follow **Pressure Relief Procedure**, page 18.

2. **Flush Gun**, page 22.

3. Remove fluid manifold (G). Leave air connected.

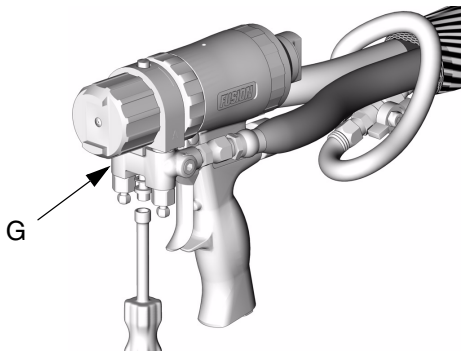

TI3852a

4. **Disassemble Front End**, page 34.

5. Remove rear rod seal nut (23) with nut driver (53).

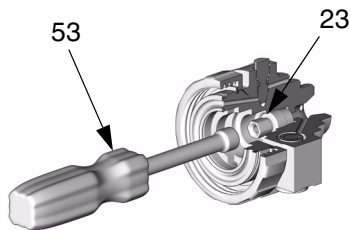

TI3869a

6. Push out rear seal (46) with screwdriver (54).

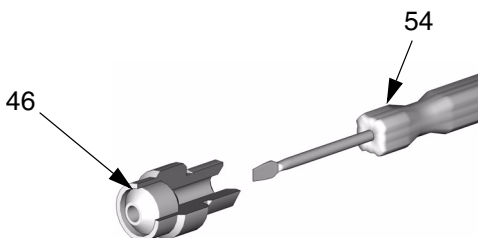

TI3872a

7. Reassemble new rear seal (46) in rear rod seal nut (23). Lubricate threads and install in fluid housing (7) with nut driver.

8. **Reassemble Front End**, page 35.

9. **Adjust Purge Rod**, page 15.

10. Attach fluid manifold. Connect air. Return gun to service.

Check Valves

 Before disassembling, press on ball (36c) to test check valve for proper movement and spring action.

1. Follow **Pressure Relief Procedure**, page 18.
2. **Flush Gun**, page 22.
3. Disconnect air (D) and remove fluid manifold (G). Clean and inspect check valve mating surfaces and fluid ports.

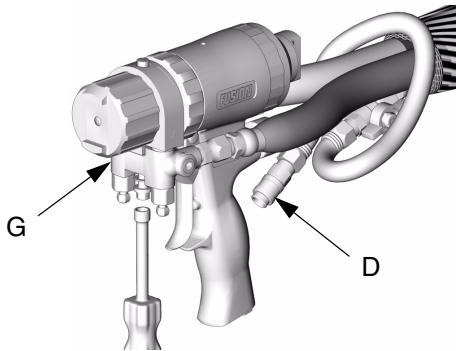

TI3837a

CAUTION

To prevent cross-contamination of the check valves, do not interchange A component and B component parts. The A component check valve is marked with an A.

4. Pry out check valves (36) at notch.

WARNING



Read warnings, page 9. Damaged check valve o-rings (36f, 36g) may result in external leakage. Replace o-rings if any damage is seen.

5. Slide filter (36d) off. Clean and inspect parts. Thoroughly inspect o-rings (36f, 36g). If necessary, remove screw (36b) and disassemble check valve.

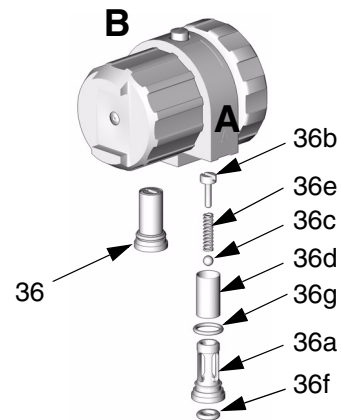

TI3836a

6. Reassemble check valves. Screw (36b) should be flush (within 1/16 in. or 1.5 mm) of housing (36a) surface. Liberally lubricate o-rings (36f, 36g) and carefully reinstall in fluid housing.
7. Attach fluid manifold. Connect air. Return gun to service.

Piston and Purge Rod

1. Follow **Pressure Relief Procedure**, page 18.

2. **Flush Gun**, page 22.

3. Disconnect air (D) and remove fluid manifold (G).

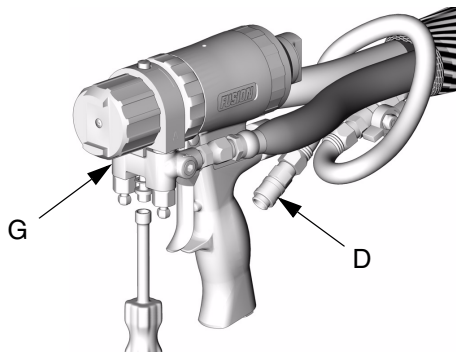

TI3837a

4. **Disassemble Front End**, page 34.

5. Unscrew purge rod stop (15) to remove piston safety lock assembly. Inspect o-rings (14, 18) in place.

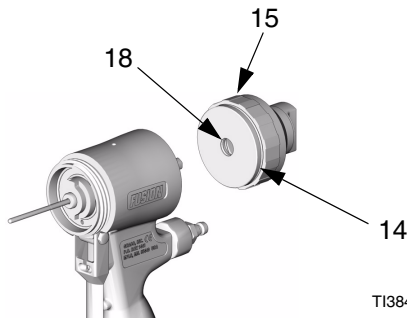

TI3847a

6. Pull purge rod to remove piston (32). Inspect piston o-ring (16) and shaft o-ring (19).

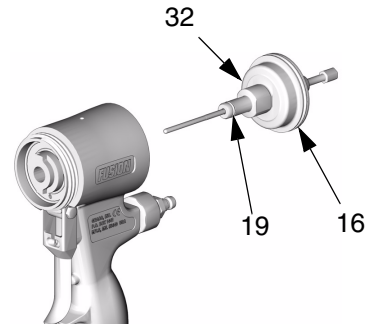

TI3846a

7. Inspect purge rod (31) for scratches or damage. Unscrew rod from piston with nut driver. Inspect o-ring (18). Liberally lubricate with Fusion Gun Lubricant, page 51. To reassemble, thread purge rod (31) into piston (32) just until o-ring (18) is not visible.

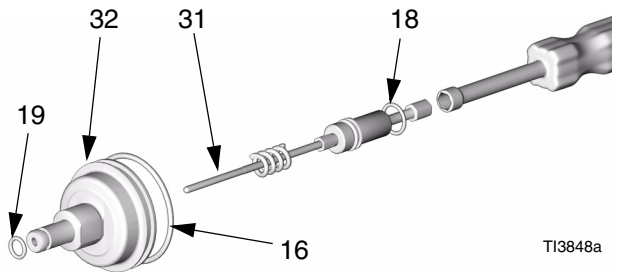

TI3848a

8. Liberally lubricate piston o-rings. Reinstall piston. Shaft is keyed for proper assembly. Push firmly to seat piston. Rotate piston/purge rod assembly clockwise with nut driver until piston is fully seated.

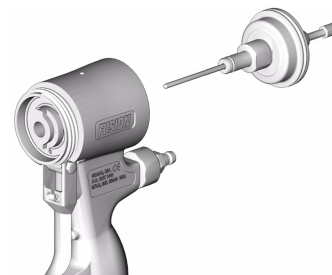

TI3846a

9. Install piston safety lock assembly until bottomed out.



T13847a

10. Reassemble Front End, page 35.
11. Adjust Purge Rod, page 15.
12. Attach fluid manifold. Connect air. Return gun to service.

Piston Safety Lock

1. Follow **Pressure Relief Procedure**, page 18.
2. **Flush Gun**, page 22.
3. Disconnect air (D) and remove fluid manifold (G).

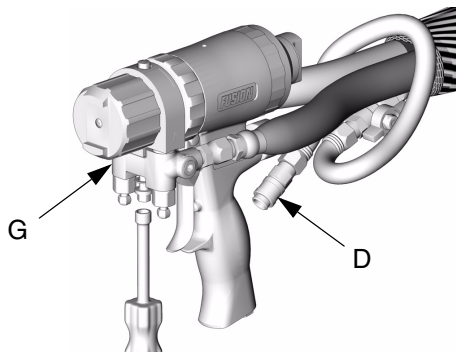

TI3837a

4. Unscrew cap (10) from stop (15), using two pair of channel-lock pliers. Inspect spring (17), safety actuator (3), bushing (4), and o-rings (14, 18).

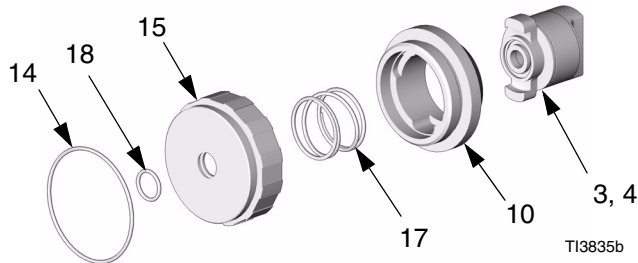

TI3835b

5. Lubricate o-rings (14, 18) and piston safety lock actuator (3), and reassemble. Use Fusion Gun Lubricant, page 51. Clean threads with solvent or alcohol. Apply medium-strength Loctite® or equivalent to threads on stop (15) and cap (10), and reassemble.
6. Attach fluid manifold. Connect air. Return gun to service.

Air Valve

1. Follow **Pressure Relief Procedure**, page 18.
2. **Flush Gun**, page 22.
3. Disconnect air (D) and remove fluid manifold (G).

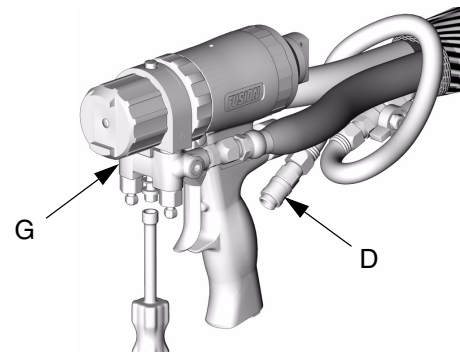

TI3837a

4. Unscrew air valve plug (2) and remove spring (26). Using small screwdriver (54), push spool (27) out from front. Inspect o-rings (24).

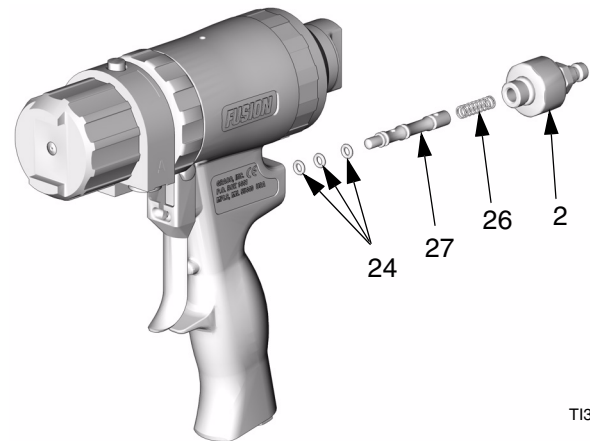

TI3834a

5. Liberally lubricate o-rings and reassemble. Use Fusion Gun Lubricant, page 51. Torque plug (2) to 125-135 in-lb (14-15 N•m).
6. Attach fluid manifold. Connect air. Return gun to service.

Parts

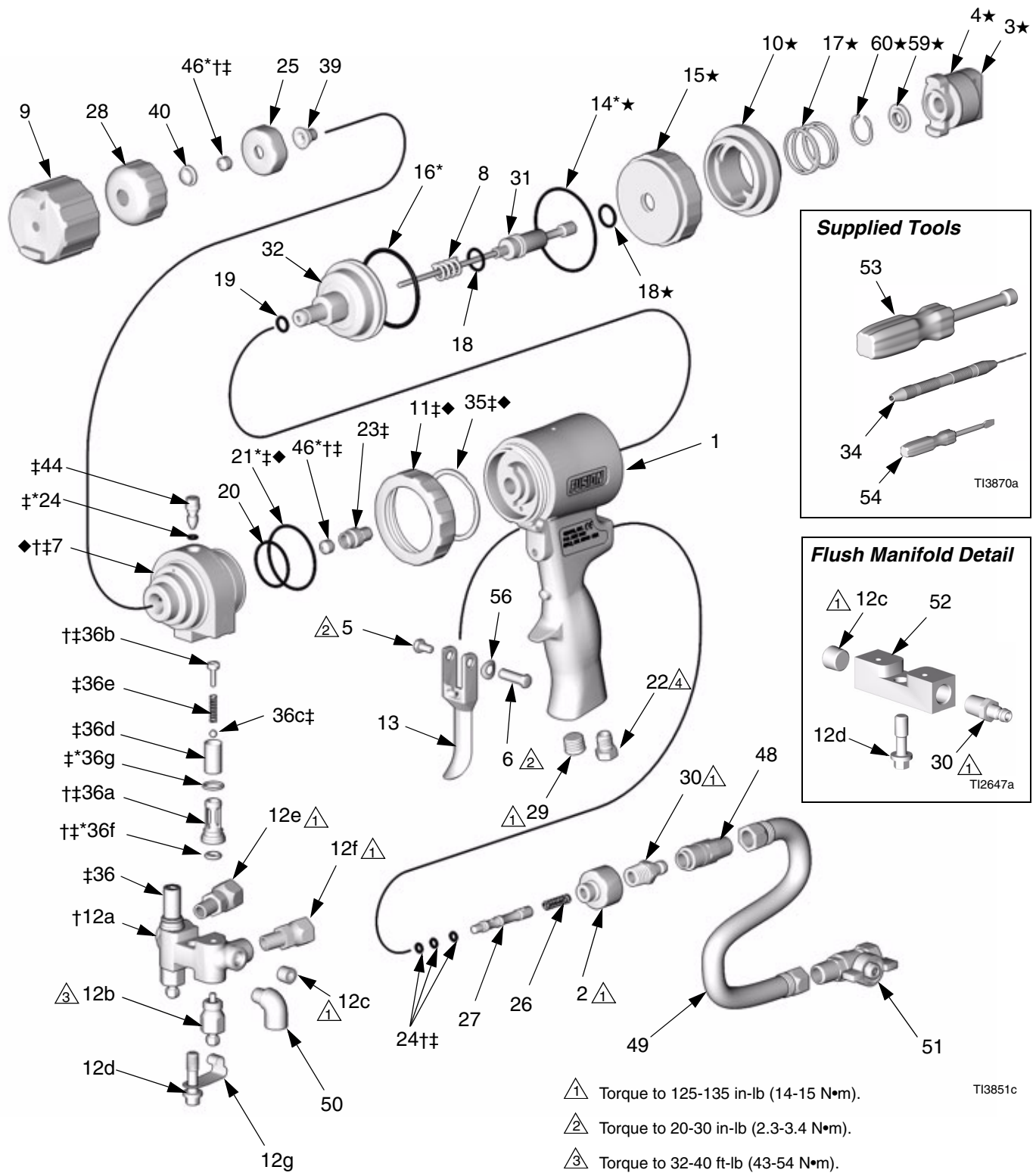

Supplied Tools

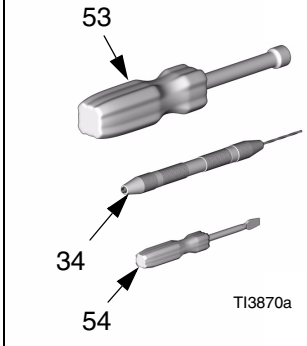

Flush Manifold Detail

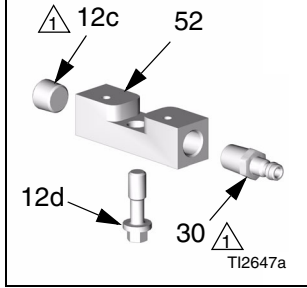

- △1 Torque to 125-135 in-lb (14-15 N•m).
- △2 Torque to 20-30 in-lb (2.3-3.4 N•m).
- △3 Torque to 32-40 ft-lb (43-54 N•m).
- △4 Torque to 35-45 in-lb (4-5 N•m).

T13851c

Ref. No.	Part No.	Description	Qty
1	248002	HANDLE	1
2	15B208	PLUG, air valve	1
3★	15C374	ACTUATOR; safety	1
4★	15C390	BUSHING, safety	1
5	203953	SCREW; 10-24 x 3/8 in. (10 mm)	1
6	192272	PIN	1
7†‡◆		HOUSING, fluid	1
8	118145	SPRING, purge rod	1
9	15C375	AIR CAP	1
10★	15C373	CAP, rear	1
11†◆	15B215	RING, lock	1
12	246012	MANIFOLD, fluid; includes 12a-12g	1
12a†		. MANIFOLD	1
12b	246356	. VALVE, fluid	2
12c	100139	. PLUG, pipe; 1/8-27 npt	2
12d	15B221	. BOLT; 5/16-24	2
12e	117634	. SWIVEL, B side; 1/8 npt(m) x no. 6 JIC(f)	1
12f	117635	. SWIVEL, A side; 1/8 npt(m) x no. 5 JIC(f)	1
12g	15B993	. SPRING, ring, lock	1
13	15B209	TRIGGER	1
14*★	248136	O-RING, rod stop; package of 6	1
15★	15C372	STOP, purge rod	1
16*	248135	O-RING, piston; package of 6	1
17★	118144	SPRING, piston safety lock	1
18★	248095	O-RING, purge rod; package of 6	1
19	248096	O-RING, piston shaft; package of 6	1
20	248138	O-RING, housing, small; package of 6	1
21†◆*	248132	O-RING, housing, large; package of 6	1
22	119626	MUFFLER	1
23‡	15C378	NUT, rod seal, rear	1
24‡*	246354	O-RING; package of 6	1
25	15C377	NUT, mix module	1
26	117485	SPRING, air valve	1
27	15B202	SPOOL, air valve	1
28	15C376	RETAINER, CeramTip	1
29	100721	PLUG, pipe; 1/4-18 npt	2
30	117509	QUICK-DISCONNECT, male, air; 1/4 npt(m)	2
31	248001	ROD, purge; includes 1 of item 18	1
32	15C371	PISTON	1
34	117661	WISE, pin; dual reversible chucks	1
35†◆	116550	RING, retaining	1

Ref. No.	Part No.	Description	Qty
36‡	246731	VALVE, check, A side; includes 36a-36g	1
	246352	VALVE, check, B side; includes 36a-36g	1
36a††		. HOUSING	1
36b††	15B214	. SCREW; 5/16-18 x 1/2 in. (13 mm)	1
36c‡	104396	. BALL; carbide	1
36d‡		. SCREEN; see page 50	1
36e‡	117490	. SPRING	1
36f†*	248133	. O-RING, check valve face; package of 6	1
36g†*	248129	. O-RING, check valve housing; package of 6	1
37▲	222385	TAG, warning; not shown	1
39		MODULE, mix, round, standard; see page 46	1
		MODULE, mix, flat, standard; see page 46	1
		MODULE, mix, round, direct impingement; see page 47	1
		MODULE, mix, flat, direct impingement; see page 47	1
40		CeramTip; see page 48	1
44‡	15C382	VALVE, cleanoff air	1
46†‡*	248003	SEAL KIT, purge rod; includes 4 seals	1
48	117510	COUPLER, air line	1
49	15B772	HOSE, air; 1/4 npsm (fbc); 18 in. (0.46 m)	1
50	112307	ELBOW, street; 1/8 npt (m x f)	2
51	113379	VALVE, ball; 1/4 npt (m x f)	1
52	15B817	MANIFOLD, gun flush	1
53	117642	NUT DRIVER, hex; 5/16	1
54	118575	SCREWDRIVER; 1/8 blade	1
55	197979	COVER, gun; not shown	1
56	15C480	WASHER, wave	1
57■	118665	LUBRICANT, Fusion Gun; 4 oz (113 gram)	1
58▲	15D235	SIGN, instruction	1
59★	15D329	STOP, rod	1
60★	115452	RING, retaining	1

* These parts are only available in repair kits. To select a kit, refer to Gun Repair Kits on page 50.

† These parts are not available singly.

‡ These parts are included in Front End Replacement Kit 246875 (includes 1 of items 24 and 46).

★ These parts are included in Safety Stop Assembly 248028 (includes 1 of item 18).

▲ Replacement Danger and Warning labels, tags, and cards are available at no cost.

■ Available in 248279 Kit, package of 10. See page 51.

◆ Available in Fluid Housing Assembly Kit 248004.

Slip-Fit Polycarbally Mix Module Kits

Slip-Fit Polycarbally Mix Module Part Numbering Code

Example Part No.	First Two Digits	Second Two Digits	Last Two Digits
MR3535	MR=Mechanical purge standard, round pattern	35=Component A impingement port size (.035 in.).***	35=Component B impingement port size (.035 in.).***
MF3535	MF=Mechanical purge standard, flat pattern		
XR3535	XR=Mechanical purge direct impingement, round pattern		
XF3535	XF=Mechanical purge direct impingement, flat pattern		

*** Some modules have multiple impingement ports (see below). Size is given as the equivalence of a single port.

Standard Round Pattern Guns

Slip-Fit Polycarbally Mix Module Kit (includes drill bits)	No. of Impingement Ports	Impingement Port Drill Bit Size, nominal**
MR3535	2	#73
MR4747	2	#67
MR5757	3	#67
MR6666	4	#67
MR8282	4	#60
MR9494	4	#56

Standard Flat Pattern Guns

Slip-Fit Polycarbally Mix Module Kit (includes drill bits)	No. of Impingement Ports	Impingement Port Drill Bit Size, nominal**	Counterbore Drill Bit Size, nominal**
MF1818	1	#77	#67
MF2929	1	#69	N/A
MF3535	2	#73	N/A
MF4747	2	#67	N/A
MF5757	3	#67	N/A

For further information, see identification chart under **Drill Bit Kits, page 49.

Direct Impingement Round Pattern Guns

Slip-Fit Polycarballoy Mix Module Kit (includes drill bits)	No. of Impingement Ports	Impingement Port Drill Bit Size, nominal**
XR2323	1	#74
XR2929	1	#69
XR3535	2	#73
XR4747	2	#67
XR5757	3	#67

Direct Impingement Flat Pattern Guns

Slip-Fit Polycarballoy Mix Module Kit (includes drill bits)	No. of Impingement Ports	Impingement Port Drill Bit Size, nominal**	Counterbore Drill Bit Size, nominal**
XF1313	1	#81	#67
XF1818	1	#77	#67
XF2323	1	#74	N/A
XF2929	1	#69	N/A
XF3535	2	#73	N/A
XF4747	2	#67	N/A
XF5757	3	#67	N/A

For further information, see identification chart under **Drill Bit Kits, page 49.

CeramTip Kits

Round CeramTip Part Numbering Code

Example Part No.	First Three Digits	Last Three Digits
RTM055	RTM=Round CeramTip mechanical purge	Equivalent orifice diameter size (.055 in.)

Round CeramTips (include drill bit)

CeramTip Part No.	Drill Bit Size, nominal**
RTM024	#73
RTM030	#67
RTM040	#60
RTM055	#54
RTM070	#50
RTM080	2.0 mm
RTM090	#43
RTM100	#39
RTM110	7/64

For further information, see identification chart under **Drill Bit Kits, page 49.

Flat CeramTip Part Numbering Code

Example Part No.	First Three Digits	Fourth Digit	Last Two Digits
FTM848	FTM=Flat CeramTip mechanical purge	8x2=pattern length (8x2=16 in.)	Equivalent orifice diameter size (.048 in.)

Flat CeramTips

CeramTip Part No.	Pattern Size, in. (mm)
FTM317	very low flow, 6-8 (152-203)
FTM424	low flow, 8-10 (203-254)
FTM438	medium flow, 8-10 (203-254)
FTM624	low flow, 12-14 (305-356)
FTM638	medium flow, 12-14 (305-356)
FTM838	medium flow, 16-18 (406-457)
FTM848	high flow, 16-18 (406-457)

Drill Bit Kits

For cleaning gun ports and orifices. Illustrations are actual size, for comparison.



Not all sizes are used with your gun.

Kit Part No.	Qty in Kit	Drill Bit Size			Illustration
		nominal	in.	mm	
246623	3	#32	0.116	2.90	
246810	3	7/64	0.109	2.77	
246813	3	#39	.099	2.51	
246624	3	3/32	.094	2.39	
246812	3	#43	.089	2.26	
246625	3	#44	.086	2.18	
246811	3	2 mm	.079	2.00	
246626	6	#50	.070	1.78	
248893	6	1/16	.062	1.59	
246627	6	#53	.060	1.52	
246809	6	#54	.055	1.40	
246628	6	#55	.052	1.32	
246814	6	#56	.046	1.18	
246629	6	#58	.042	1.07	
246808	6	#60	.040	1.02	
248618	6	#63	.037	0.94	
248891	6	#66	.033	0.84	
246807	6	#67	.032	0.81	
246630	6	#69	.029	0.74	
248892	6	#70	.028	0.71	
246815	6	#73	.024	0.61	
276984	6	#74	.023	0.57	
246631	6	#76	.020	0.51	
246816	6	#77	.018	0.46	
246817	6	#81	.013	0.33	

Gun Repair Kits

Read the chart left to right and top to bottom to find the quantity of each part in the kits.

Ref. No.	Bulk O-ring Kits, (qty)	246351 Check Valve O-ring Kit	248000 Complete O-ring Kit
14	248136 (6)		1
16	248135 (6)		1
18	248095 (6)		2
19	248096 (6)		1
20	248138 (6)		1
21	248132 (6)		1
24	246354 (6)		4
36f	248133 (6)	2	
36g	248129 (6)	2	
46	248003 (4)		

Check Valve Filter Screen Kits (10 per kit)

80 mesh filter screen is standard with gun.

246357 40 mesh (.015 in., 375 micron)

246358 60 mesh (.010 in., 238 micron)

246359 80 mesh (.007 in., 175 micron)

Accessories

Gun Cover

244915

Keeps gun clean while spraying. Pack of 10.

Fusion Gun Lubricant Kit

248279 Pack of 10 Tubes, 4 oz (113 gram)

High adhesion, water resistant, lithium-based lubricant for rebuilding Fusion Gun. MSDS sheet MSD025 available at www.graco.com.

Tip Cleanout Tool

15D234

Designed to fit CeramTip internal dome and flat tip slits.

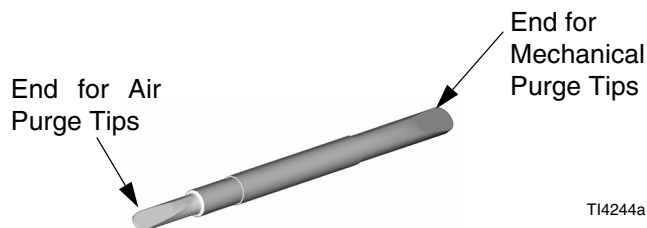

Circulation Manifold

246362

Attach to gun fluid manifold to enable preheating of hose. See manual 309818.

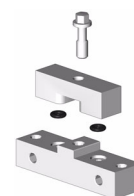

Flushing Manifold

15B817 Manifold Block

See ref. no. 52, page 45.

Solvent Flush Kits

248139 1 qt (0.95 liter) Solvent Cup

Portable, for remote solvent flush. Includes 15B817 Flushing Manifold. See manual 309963.



Solvent Flush Pail Kit

248229 5.0 gal. (19 liter) Pail

Includes flush manifold with individual A and B shutoff valves, and air regulator. See manual 309963.

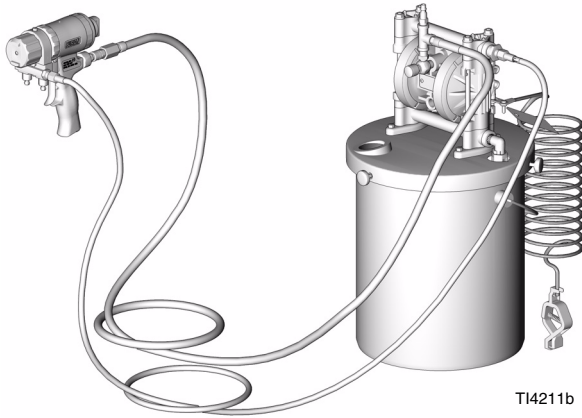

Hose Adapter Kits

246944

To connect non-Graco gun to Graco heated hose.

248029

To connect Graco Fusion gun to non-Graco D-gun hose set.

246945

To connect Graco Fusion gun to non-Graco heated hose.

Pour Nozzle Kit

248682

To convert mechanical purge gun for pour applications. Includes nozzle, retainer, and tip.

Technical Data

Category	Data
Maximum Fluid Working Pressure	3500 psi (24.2 MPa, 242 bar)
Minimum Air Inlet Pressure	80 psi (0.55 MPa, 5.5 bar)
Maximum Air Inlet Pressure	130 psi (0.9 MPa, 9 bar)
Maximum Fluid Temperature	200° F (94° C)
Air Inlet Size	1/4 npt Quick Disconnect Nipple
A Component (ISO) Inlet Size	-5 JIC; 1/2-20 UNF
B Component (Resin) Inlet Size	-6 JIC; 9/16-18 UNF
Typical Flow Rate	See charts pages 4-7.
Sound Pressure	70 dB(A), at 100 psi (0.7 MPa, 7 bar)
Sound Power, measured per ISO 9416-2	79.9 dB(A), at 100 psi (0.7 MPa, 7 bar)
Length	7.6 in. (193 mm)
Height	8.1 in. (206 mm)
Width	3.1 in. (79 mm)
Weight	2.9 lb (1.32 kg)
Wetted Parts	Aluminum, stainless steel, carbon steel, chemically resistant o-rings, ultra-high molecular weight polyethylene (UHMWPE), Polycarbally™, CeramTip™

All other brand names or marks are used for identification purposes and are trademarks of their respective owners.

Graco Standard Warranty

Graco warrants all equipment referenced in this document which is manufactured by Graco and bearing its name to be free from defects in material and workmanship on the date of sale to the original purchaser for use. With the exception of any special, extended, or limited warranty published by Graco, Graco will, for a period of twelve months from the date of sale, repair or replace any part of the equipment determined by Graco to be defective. This warranty applies only when the equipment is installed, operated and maintained in accordance with Graco's written recommendations.

This warranty does not cover, and Graco shall not be liable for general wear and tear, or any malfunction, damage or wear caused by faulty installation, misapplication, abrasion, corrosion, inadequate or improper maintenance, negligence, accident, tampering, or substitution of non-Graco component parts. Nor shall Graco be liable for malfunction, damage or wear caused by the incompatibility of Graco equipment with structures, accessories, equipment or materials not supplied by Graco, or the improper design, manufacture, installation, operation or maintenance of structures, accessories, equipment or materials not supplied by Graco.

This warranty is conditioned upon the prepaid return of the equipment claimed to be defective to an authorized Graco distributor for verification of the claimed defect. If the claimed defect is verified, Graco will repair or replace free of charge any defective parts. The equipment will be returned to the original purchaser transportation prepaid. If inspection of the equipment does not disclose any defect in material or workmanship, repairs will be made at a reasonable charge, which charges may include the costs of parts, labor, and transportation.

THIS WARRANTY IS EXCLUSIVE, AND IS IN LIEU OF ANY OTHER WARRANTIES, EXPRESS OR IMPLIED, INCLUDING BUT NOT LIMITED TO WARRANTY OF MERCHANTABILITY OR WARRANTY OF FITNESS FOR A PARTICULAR PURPOSE.

Graco's sole obligation and buyer's sole remedy for any breach of warranty shall be as set forth above. The buyer agrees that no other remedy (including, but not limited to, incidental or consequential damages for lost profits, lost sales, injury to person or property, or any other incidental or consequential loss) shall be available. Any action for breach of warranty must be brought within two (2) years of the date of sale.

GRACO MAKES NO WARRANTY, AND DISCLAIMS ALL IMPLIED WARRANTIES OF MERCHANTABILITY AND FITNESS FOR A PARTICULAR PURPOSE, IN CONNECTION WITH ACCESSORIES, EQUIPMENT, MATERIALS OR COMPONENTS SOLD BUT NOT MANUFACTURED BY GRACO. These items sold, but not manufactured by Graco (such as electric motors, switches, hose, etc.), are subject to the warranty, if any, of their manufacturer. Graco will provide purchaser with reasonable assistance in making any claim for breach of these warranties.

In no event will Graco be liable for indirect, incidental, special or consequential damages resulting from Graco supplying equipment hereunder, or the furnishing, performance, or use of any products or other goods sold hereto, whether due to a breach of contract, breach of warranty, the negligence of Graco, or otherwise.

FOR GRACO CANADA CUSTOMERS

The Parties acknowledge that they have required that the present document, as well as all documents, notices and legal proceedings entered into, given or instituted pursuant hereto or relating directly or indirectly hereto, be drawn up in English. Les parties reconnaissent avoir convenu que la rédaction du présente document sera en Anglais, ainsi que tous documents, avis et procédures judiciaires exécutés, donnés ou intentés, à la suite de ou en rapport, directement ou indirectement, avec les procédures concernées.

Graco Information

TO PLACE AN ORDER, contact your Graco distributor, or call this number to identify the distributor closest to you:

1-800-328-0211 Toll Free

612-623-6921

612-378-3505 Fax

All written and visual data contained in this document reflects the latest product information available at the time of publication. Graco reserves the right to make changes at any time without notice. (SRC309856)

Sales Office: Minneapolis

International Offices: Belgium, Korea, Hong Kong, Japan

GRACO INC. P.O. BOX 1441 MINNEAPOLIS, MN 55440-1441

www.graco.com

Printed in USA 309856E (English)

06/2004, Rev. 11/2004