

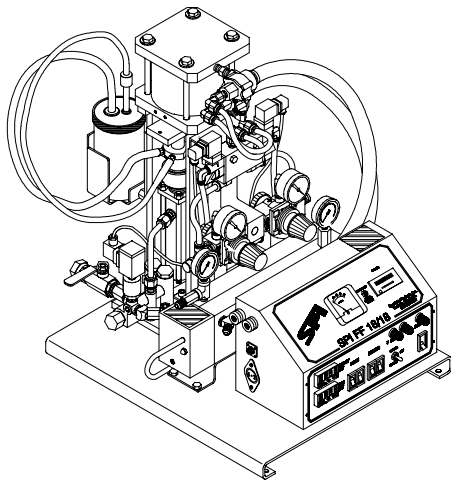

"Success through Unity"



Model SPI FF 18/18 Proportioning Unit

Parts Identification Manual 17942-SPI-ID

July 3, 2001

Issue 5



GUSMER CORPORATION®

A Subsidiary of Gusmer Machinery Group, Inc.
One Gusmer Drive
Lakewood, New Jersey, USA 08701-8055
Toll Free 1-800-367-4767 (USA & Canada)
Phone: (732) 370-9000
Fax: (732) 905-8968

Copyright 2001, GUSMER CORPORATION®

<http://www.gusmer.com>

NOTICE: This manual contains important information for your GUSMER equipment. Read and retain for future reference.

***NOTICE:** The equipment described in this technical manual must only be operated or serviced by properly trained individuals, thoroughly familiar with the operating instructions and limitations of the equipment. For technical service, call your local distributor. Call: 1-800-FOR-GSMR (1-800-367-4767) for the name and telephone number of your local distributor.*

***NOTICE:** All statements, information and data given herein are believed to be accurate and reliable but are presented without guarantee, warranty or responsibility of any kind expressed or implied. Statements or suggestions concerning possible use of GUSMER equipment are made without representation or warranty that any such use is free of patent infringement, and are not recommendations to infringe any patent. The user should not assume that all safety measures are indicated or that other measures may not be required*

CONTENTS

LIST OF FIGURES4

LIST OF TABLES4

WARRANTY.....5

ASSEMBLIES.....6

 SPI FF 18/18 FINAL ASSEMBLY6

 ELECTRIC CONSOLE8

 AIR MOTOR12

 REVERSING SWITCH.....14

 AIR CONTROL SYSTEM.....16

 PRIMARY HEATER.....18

 PROPORTIONING PUMP20

 POWER PACK.....22

 LUBE PUMP ASSEMBLY24

ELECTRICAL SCHEMATIC DIAGRAMS.....25

INSTRUCTION MANUAL DISCREPANCY REPORT29

LIST OF FIGURES

FIGURE 1. SPI FF 18/18 ASSEMBLY, (PART NO. 17000A-1-SPI), EXPLODED VIEW	6
FIGURE 2. ELECTRIC CONSOLE, (PART NO. 17650A-220-SPI), EXPLODED VIEW, SHEET 1 OF 3	8
FIGURE 3. ELECTRIC CONSOLE, (PART NO. 17650A-220-SPI), EXPLODED VIEW, SHEET 2 OF 3	9
FIGURE 4. ELECTRIC CONSOLE, (PART NO. 17650A-220-SPI), EXPLODED VIEW, SHEET 3 OF 3	10
FIGURE 5. AIR MOTOR, (PART NO. 17755-SPI), EXPLODED VIEW	12
FIGURE 6. REVERSING SWITCH, (PART NO. 25745-10), EXPLODED VIEW	14
FIGURE 7. AIR CONTROL SYSTEM, (PART NO. 17756), EXPLODED VIEW	16
FIGURE 8. PRIMARY HEATER, (PART NO. 17360), EXPLODED VIEW	18
FIGURE 9. PROPORTIONING PUMP, (PART NO. 17400/17450-60-SPI), EXPLODED VIEW	20
FIGURE 10. POWER PACK, (PART NO. 1276), EXPLODED VIEW.....	22
FIGURE 11. LUBE PUMP ASSEMBLY, (PART NO. 17491-60), EXPLODED VIEW.....	24
FIGURE 12. SPI FF 18/18 ELECTRICAL SCHEMATIC, (SD17000A-1-SPI), SHEET 1 OF 2.....	25
FIGURE 13. SPI FF 18/18 ELECTRICAL SCHEMATIC, (SD17000A-1-SPI), SHEET 2 OF 2.....	26

LIST OF TABLES

TABLE 1. SPI FF 18/18 ASSEMBLY, (PART NO. 17000A-1-SPI), PARTS.....	7
TABLE 2. ELECTRIC CONSOLE, (PART NO. 17650A-220-SPI), PARTS, SHEET 1 OF 3	8
TABLE 3. ELECTRIC CONSOLE, (PART NO. 17650A-220-SPI), PARTS, SHEET 2 OF 3	9
TABLE 4. ELECTRIC CONSOLE, (PART NO. 17650A-220-SPI), PARTS, SHEET 3 OF 3	11
TABLE 5. AIR MOTOR, (PART NO. 17755-SPI), PARTS	13
TABLE 6. REVERSING SWITCH, (PART NO. 25745-10), PARTS.....	15
TABLE 7. AIR CONTROL SYSTEM, (PART NO. 17756), PARTS	17
TABLE 8. PRIMARY HEATER, (PART NO. 17360), PARTS.....	19
TABLE 9. PROPORTIONING PUMP, (PART NO. 17400/17450-60-SPI), PARTS	21
TABLE 10. POWER PACK, (PART NO. 1276), PARTS	23
TABLE 11. LUBE PUMP ASSEMBLY, (PART NO. 17491-60), PARTS	24
TABLE 12. SPI FF 18/18 ELECTRICAL SCHEMATIC, (SD17000A-1-SPI), PARTS	27

WARRANTY

Gusmer Corporation (Gusmer) provides a limited warranty to the original purchaser (Customer) of Gusmer manufactured parts and equipment (Product) against any defects in material or workmanship for a period of one year from the date of shipment from Gusmer facilities.

In the event Product is suspected to be defective in material or workmanship, it must be returned to Gusmer, freight prepaid. If Product is found to be defective in material or workmanship, as determined solely by Gusmer, Gusmer will issue full credit to Customer for the freight charges incurred in returning the defective Product, and either credit will be issued for the replacement cost of the Product or a replacement part will be forwarded no-charge, freight prepaid to Customer.

This warranty shall not apply to Product Gusmer finds to be defective resulting from: installation, use, maintenance, or procedures not accomplished in accordance with our instructions; normal wear; accident; negligence; alterations not authorized in writing by Gusmer; use of "look alike" parts not manufactured or supplied by Gusmer; or Product used in conjunction with any other manufacturer's pumping or proportioning equipment. Further, the terms and conditions of this warranty shall not apply to services or repairs made to Product by any third party not authorized in writing by Gusmer. For such Product, a written estimate will be submitted to Customer at a nominal service charge, itemizing the cost for repair. Disposition of Product will be done in accordance with the terms stated on the written estimate.

The warranty provisions applied to product that are not manufactured by Gusmer will be solely in accordance with the warranty provided by the original manufacturer of the product.

GUSMER MAKES NO WARRANTY WHATSOEVER AS TO THE MERCHANTABILITY OF, OR SUITABILITY FOR, ITS PRODUCT TO PERFORM ANY PARTICULAR PURPOSE. CREDIT FOR, OR REPLACEMENT OF, PRODUCT DEFECTIVE IN MATERIAL OR WORKMANSHIP SHALL CONSTITUTE COMPLETE FULFILLMENT OF GUSMER OBLIGATIONS TO CUSTOMER. NO OTHER WARRANTY, EXPRESSED OR IMPLIED ON ANY PRODUCT IT MANUFACTURES AND/OR SELLS, WILL BE RECOGNIZED BY GUSMER UNLESS SAID WARRANTY IS IN WRITING AND APPROVED BY AN OFFICER OF GUSMER.

Under no circumstances shall Gusmer be liable for loss of prospective or speculative profits, or special indirect, incidental or consequential damages. Further, Gusmer shall have no liability for any expenses including, but not limited to personal injury or property damage resulting from failure of performance of the product, use of the product, or application of the material dispensed through the product. Any information provided by Gusmer that is based on data received from a third source, or that pertains to product not manufactured by Gusmer, while believed to be accurate and reliable, is presented without guarantee, warranty, or responsibility of any kind, expressed or implied.

Gusmer through the sale, lease, or rental of Product in no way expresses or implies a license for the use of, nor encourages the infringement of any patents or licenses.

To insure proper validation of your warranty, please complete the warranty card and return it to Gusmer within two weeks of receipt of equipment.

Revised 11/12/98

ASSEMBLIES

SPI FF 18/18 FINAL ASSEMBLY

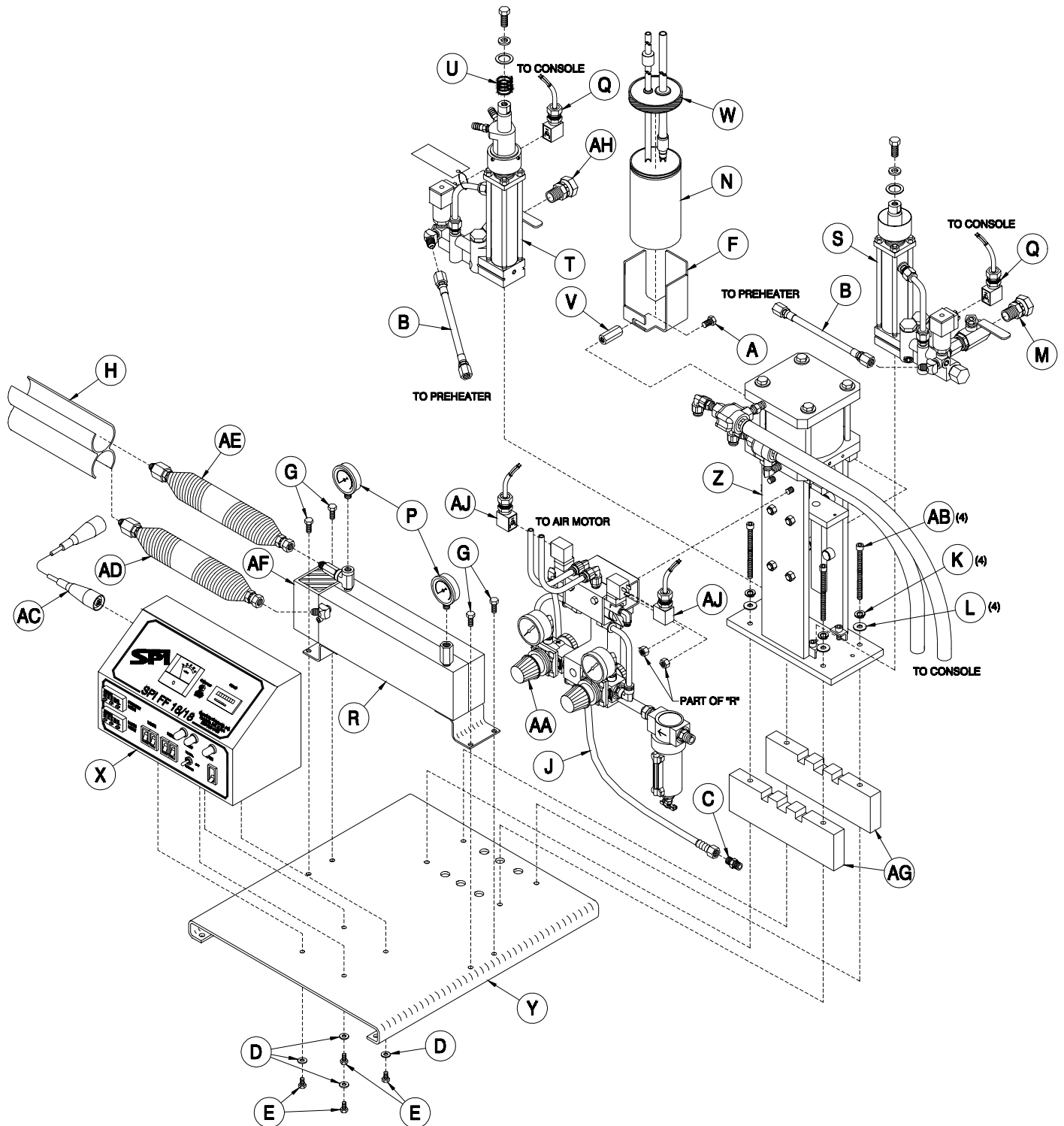

Figure 1. SPI FF 18/18 Assembly, (Part No. 17000A-1-SPI), Exploded View

TABLE 1. SPI FF 18/18 ASSEMBLY, (PART NO. 17000A-1-SPI), PARTS

Reference Letter	Part Number	Description	Quantity
A	0203-28	Hex Head Cap Screw	1
B	0372	Interconnecting Hose	2
C	0561	Hex Nipple	1
D	0562-11-3	Flat Washer	4
E	0760-3	Hex Head Cap Screw	4
F	1486A	Lube Reservoir Bracket	1
G	1701-4	Hex Head Cap Screw	4
H	5204	Electrical Isolator	1
J	5270A-4	Air Hose Assembly	1
K	5504-3	Helical Lockwasher	4
L	5829-7	Flat Washer	4
M	10420	Swivel Union	1
N	15586	Lube Bottle	1
P	17001	0-3000 PSI Gauge	2
Q	6690-16-76-2	DIN Connector	2
R	17360	LV Primary Heater Assembly	1
S	17400-60-SPI	Resin Proportioning Pump Assembly	1
T	17450-60-SPI	Iso Proportioning Pump Assembly	1
U	17482	Spring	1
V	17483	Coupling Hex Nut	1
W	17585	Lube Reservoir Hose Assembly	1
X	17650A-220-SPI	SPI 1818 Electric Console	1
Y	17755-SPI	Machine Base	1
Z	17755-SPI	Air Motor SPI	1
AA	17756	Air Control System	1
AB	20077-20-1	Socket Head Cap Screw	4
AC	20207-3	TSU Extension Adapter	1
AD	56273	R - Isolation Hose	1
AE	56274	A - Isolation Hose	1
AF	56355	Heater Electrical Box	1
AG	57754	Air Motor Standoff	2
AH	OP179-6	Swivel Union	1
AJ	8680-3-3	DIN Connector	2
AK	17358	Insulator Blanket (Not Shown)	1

ELECTRIC CONSOLE

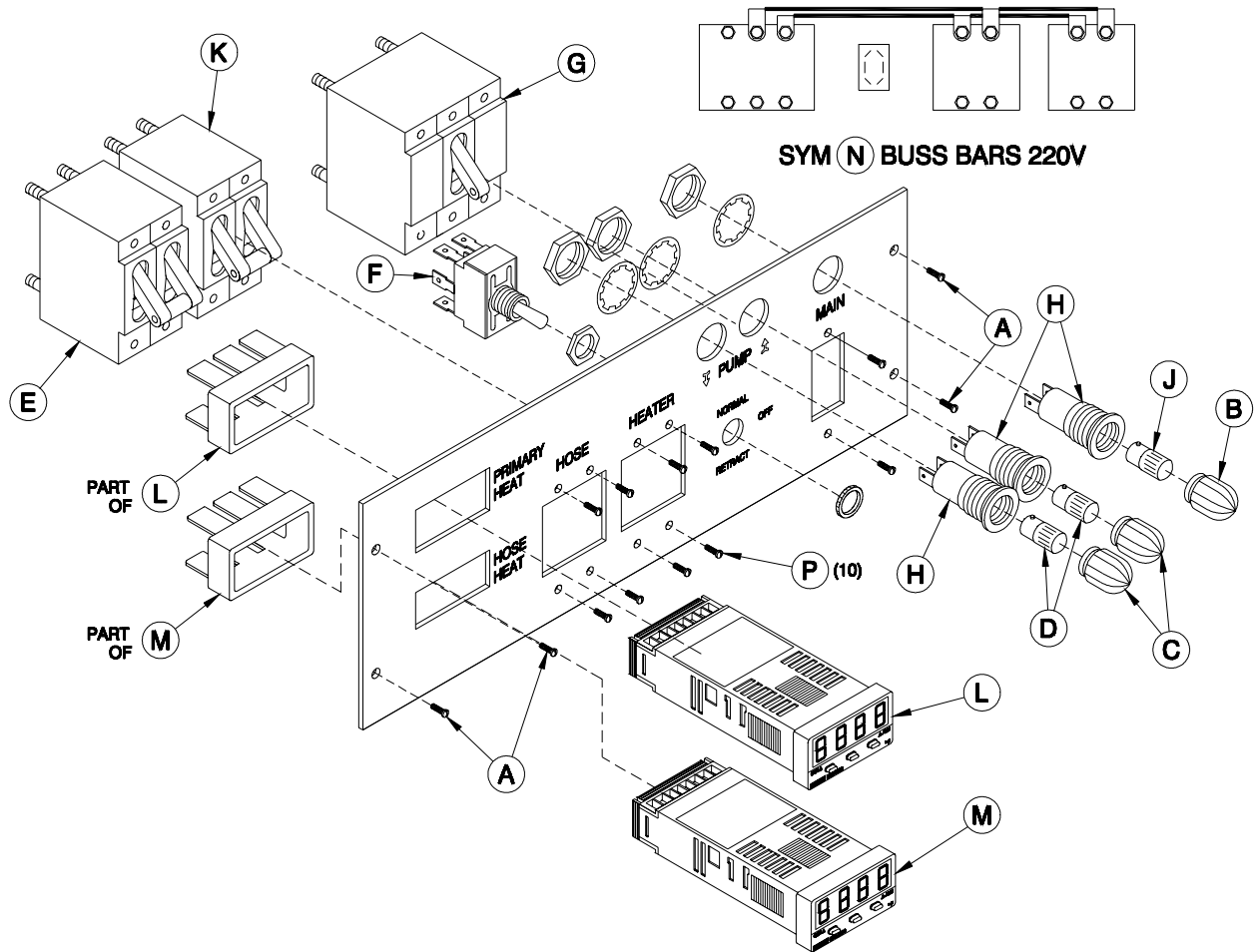

Figure 2. Electric Console, (Part No. 17650A-220-SPI), Exploded View, Sheet 1 of 3

TABLE 2. ELECTRIC CONSOLE, (PART No. 17650A-220-SPI), PARTS, SHEET 1 OF 3

Reference Letter	Part Number	Description	Quantity
A	0368	Binder Head Machine Screw	4
B	0656	White Lens	1
C	0660	Amber Lens	2
D	0662A	Incandescent Bulb	2
E	0692-1-25	25 Amp Circuit Breaker	1
F	6690-16-6	Toggle Switch	1
G	6690-16-10	Switch	1
H	6690-19-25	Light Base	3
J	6690-19-24	Bulb	1
K	6690-25-31	40 Amp Circuit Breaker	1
L	6690-26-23	Primary Heater Temperature Controller	1
M	6690-26-24	Hose Heat Temperature Controller	1
N	17650-5	Buss Bar (220V)	1
P	0205-1	Binder Head Machine Screw	10

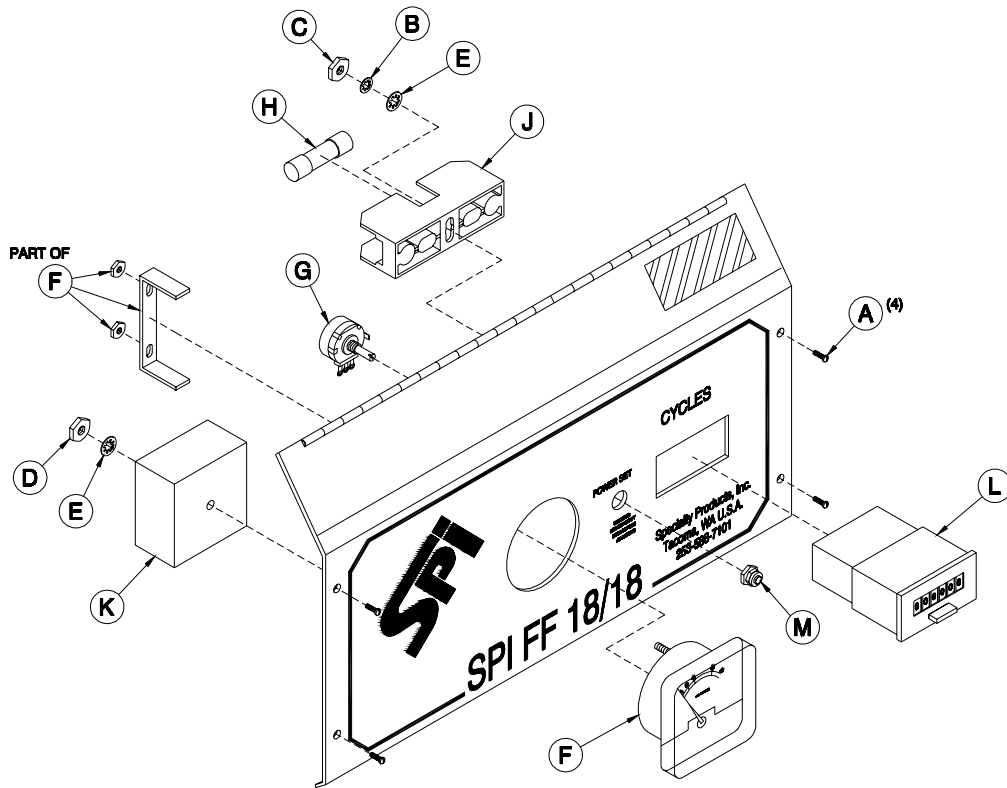

Figure 3. Electric Console, (Part No. 17650A-220-SPI), Exploded View, Sheet 2 of 3

TABLE 3. ELECTRIC CONSOLE, (PART No. 17650A-220-SPI), PARTS, SHEET 2 OF 3

Reference Letter	Part Number	Description	Quantity
A	0368	Binder Head Machine Screw	4
B	0651A-10	Internal Lockwasher	1
C	0668-3-1	Hex Nut	1
D	1701-15-9	Hex Nut	1
E	4702-7-4	Internal Lockwasher	2
F	5616-Kit	Ammeter	1
G	6690-5-17	Potentiometer	1
H	6690-24-1	Fuse	1
J	6690-24-2	Fuse Block	1
K	6690-26-18	Phase Control	1
L	9651-6-2	Counter	1
M	9651-6-5	Shaft Lock	1

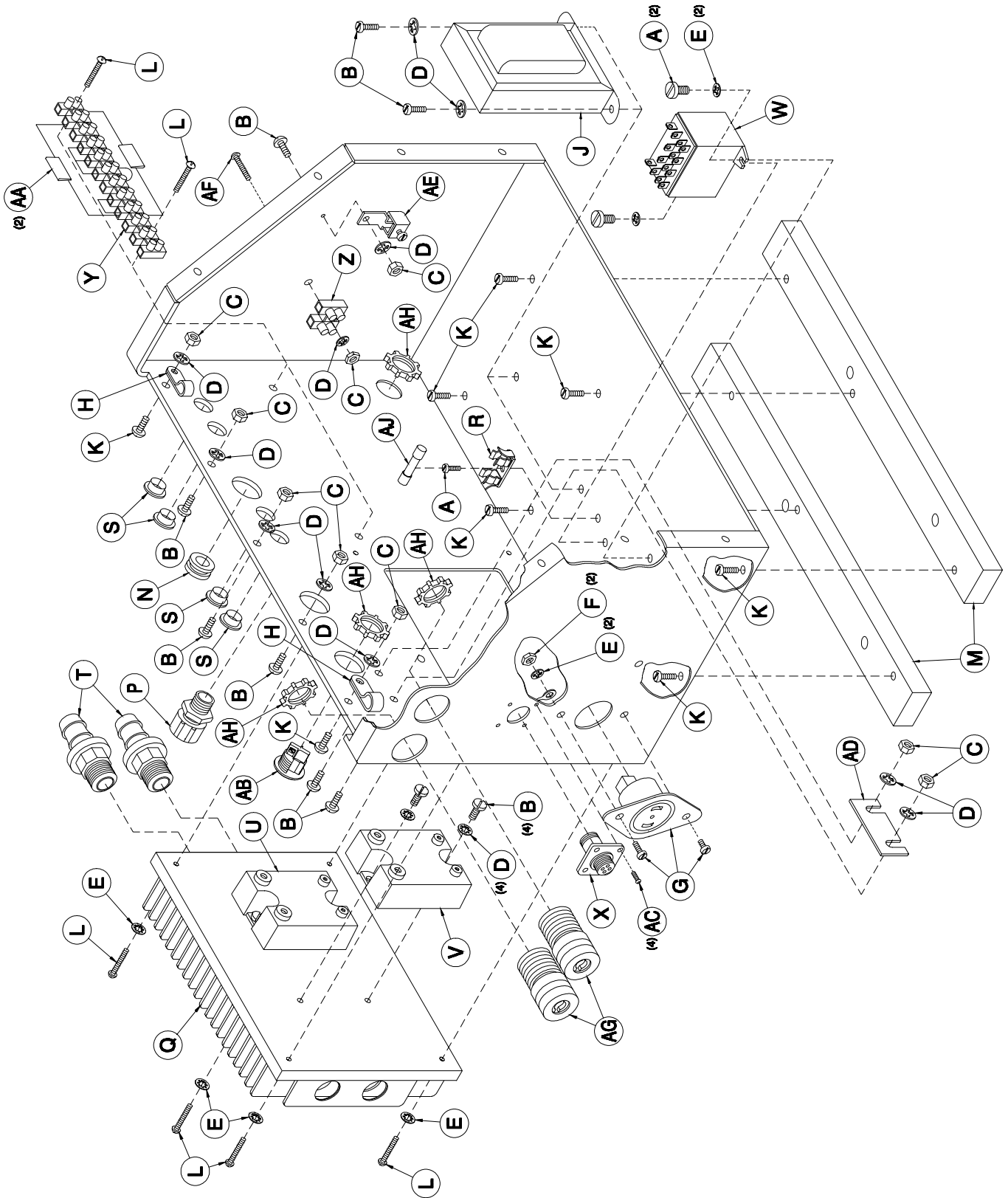

Figure 4. Electric Console, (Part No. 17650A-220-SPI), Exploded View, Sheet 3 of 3

TABLE 4. ELECTRIC CONSOLE, (PART NO. 17650A-220-SPI), PARTS, SHEET 3 OF 3

Reference Letter	Part Number	Description	Quantity
A	0368	Binder Head Machine Screw	3
B	0651A-8	Pan Head Machine Screw	12
C	0651A-9	Hex Nut	9
D	0651A-10	Internal Lockwasher	15
E	0655-4	Lockwasher	8
F	0668-3	Hex Nut	2
G	0670A-1-1	Socket	1
H	0681A	Cable Clamp	2
J	0689-1	Transformer	1
K	0689-2	Pan Head Machine Screw	8
L	0698-3	Pan Head Machine Screw	6
M	0760A-1	Console Mounting Bar	2
N	1701-16	Grommet	1
P	17650-1	Strain Relief	1
Q	17708	Heat Sink	1
R	5653B	Fuse Holder	1
S	5703D-10	Bushing	4
T	6310-27	Hose Fitting	2
U	6690-1-55-1	Solid State Relay 480/50 AM	1
V	6690-1-46	Solid State Relay 480/90 Amp	1
W	6690-1-14	Relay 10 Amp	1
X	6690-13-2-11-4	4 CKT MA Pin Housing	1
Y	6690-20-1-12	Terminal Block	1
Z	6690-20-5-2	Terminal Block	1
AA	6690-21-3	Quencharc	2
AB	6690-31-1-1	Thermocouple Socket	1
AC	9651-4	Pan Head Machine Screw	4
AD	14667	Jumper	1
AE	17650-2	Wire Lug	1
AF	60302	Round Head Machine Screw	1
AG	OP482-17-1	Bushing	2
AH	OP482-17-2	Locknut	4
AJ	OP5193-3-3	1 Amp Fuse	1

AIR MOTOR

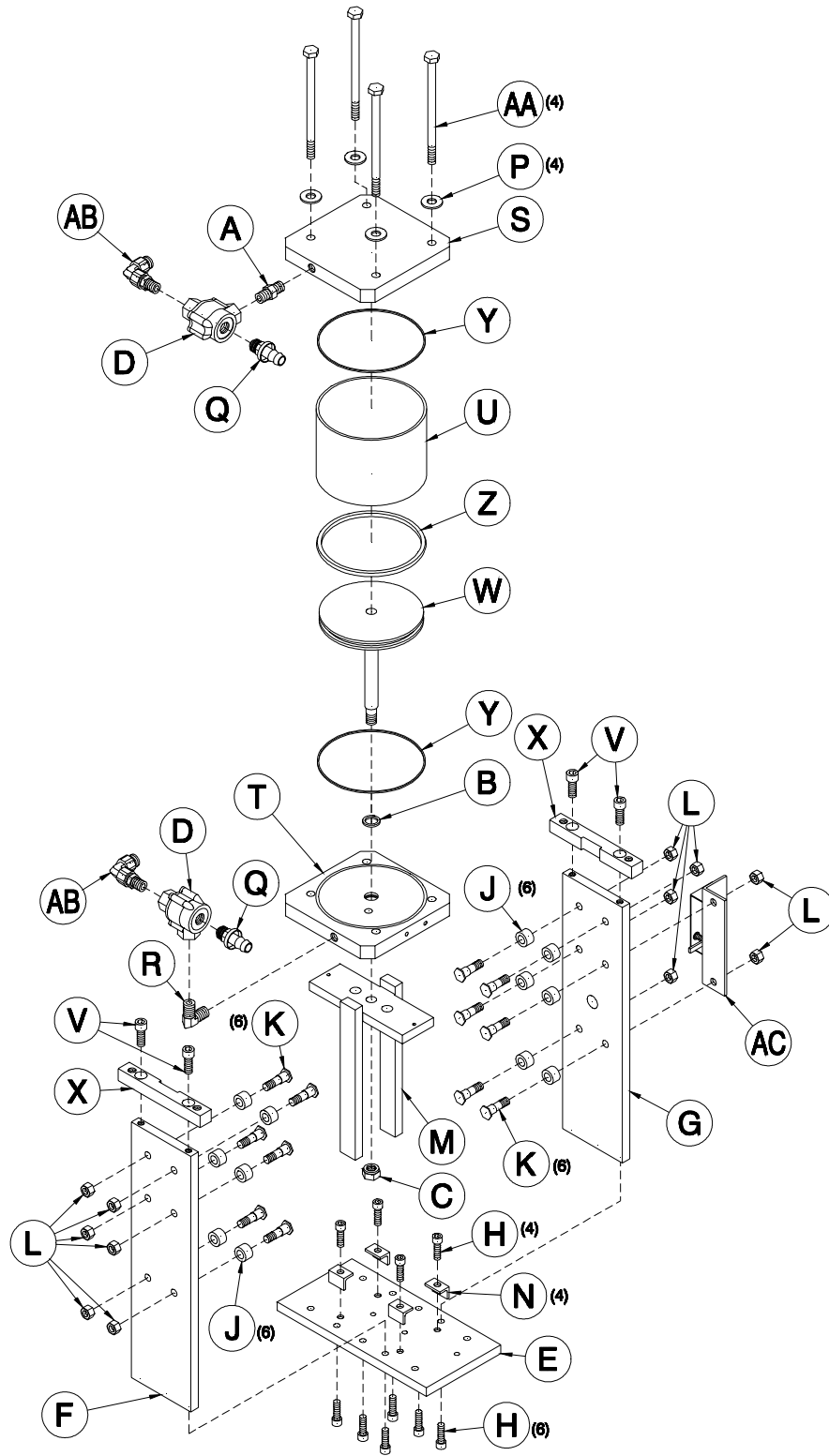

Figure 5. Air Motor, (Part No. 17755-SPI), Exploded View

TABLE 5. AIR MOTOR, (PART NO. 17755-SPI), PARTS

Reference Letter	Part Number	Description	Quantity
A	0466A	Hex Nipple	1
B	0551	O-Ring	1
C	0557	Piston Rod Nut	1
D	0562-12	Exhaust Valve	2
E	0751	Proportioner Base	1
F	0752	Air Cylinder Upright	1
G	0753	Air Cylinder Upright-Switch Side	1
H	0754	Socket Head Cap Screw	10
J	0755-1	Bearings	12
K	0755-2	Cam Roller Stud	12
L	0756	Hex Nut	12
M	0757A	Pump Yoke	1
N	0765	Pump Mounting Bracket	4
P	1516A-3	Washer	4
Q	6310-27	Hose Barb	2
R	14501-20	Elbow	1
S	17745-1	Air Cylinder Top Plate	1
T	17745-2	Air Cylinder Bottom Plate	1
U	17745-3	Air Cylinder	1
V	17745-4	Socket Head Cap Screw	4
W	17745-5	Air Piston W/Rod	1
X	17745-6	Air Cylinder Adapter	2
Y	17745-7	O-Ring	2
Z	17745-8	O-Ring	1
AA	17745-9	Hex Head Cap Screw	4
AB	20042	Tube Fitting	2
AC	25745-10	Reversing Switch Assy	1
Not Shown	6310-26	Air Hose	A/R

Air Cylinder Rebuild Kit (Part # 17745-3-1)- Includes B, Z, AA, & Air Cylinder Lubricant (Part No. 553-2) Order as required from SPI.

Exhaust Valve Repair Kit (Part No. 0562-12-1-D) Order as required from SPI.

REVERSING SWITCH

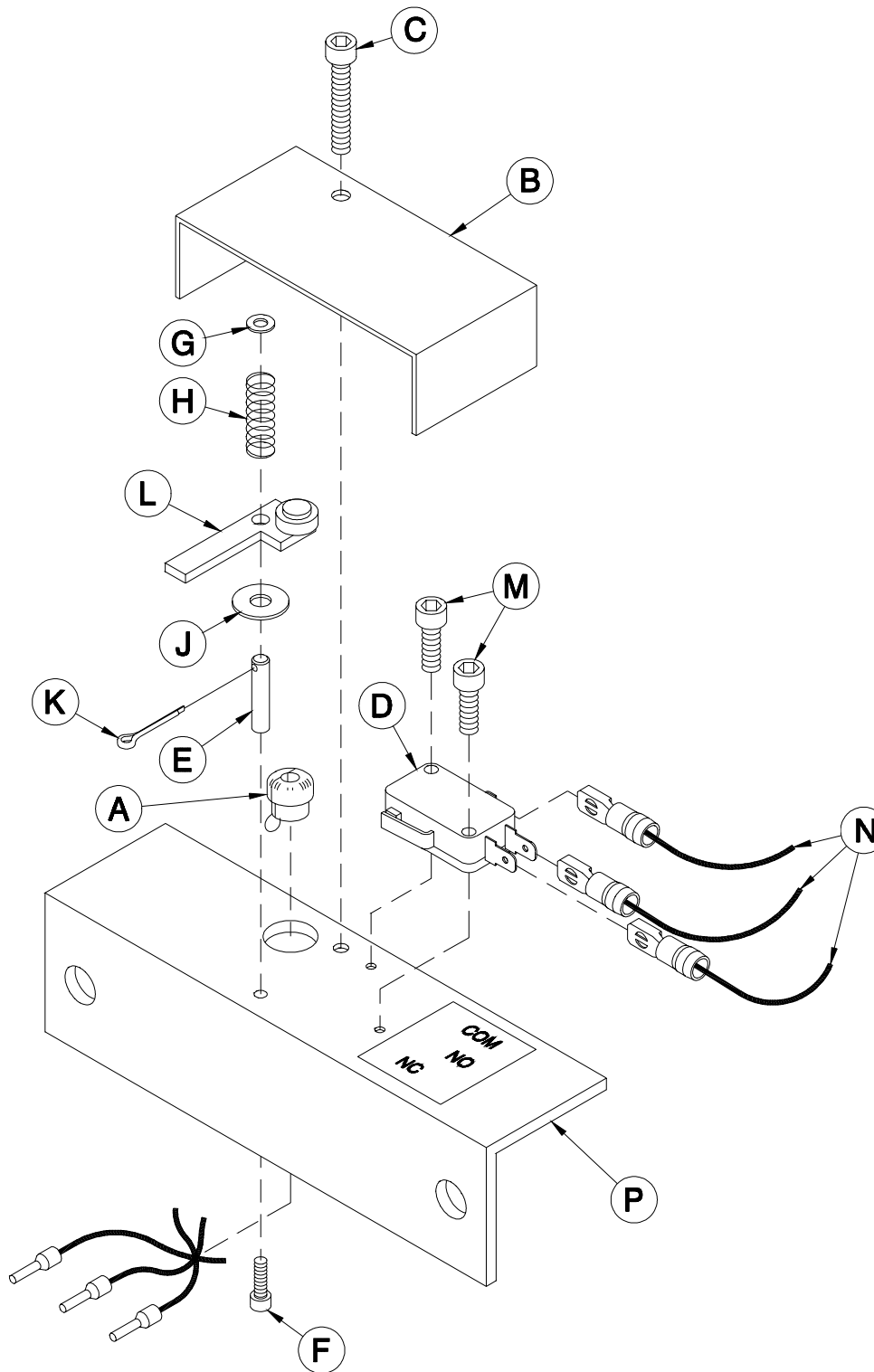

Figure 6. Reversing Switch, (Part No. 25745-10), Exploded View

TABLE 6. REVERSING SWITCH, (PART NO. 25745-10), PARTS

Reference Letter	Part Number	Description	Quantity
A	0364	Bushing	1
B	0577B-1	Reversing Switch Bracket (Includes N, F, & G)	1
C	0577-2	Reversing Switch Cover Box	1
D	0577-3	Socket Head Cap Screw	1
E	0578A	Reversing Switch	1
F	0579-2	Pivot Arm	1
G	0579-3	Socket Head Cap Screw	1
H	0579-4	Flat Washer	1
J	0579-5	Spring	1
K	0579-6	Fiber Washer	1
L	0579-7	Cotter Pin	1
M	0579A-1	Reversing Switch Lever	1
N	9577-10	Socket Head Cap Screw	2

AIR CONTROL SYSTEM

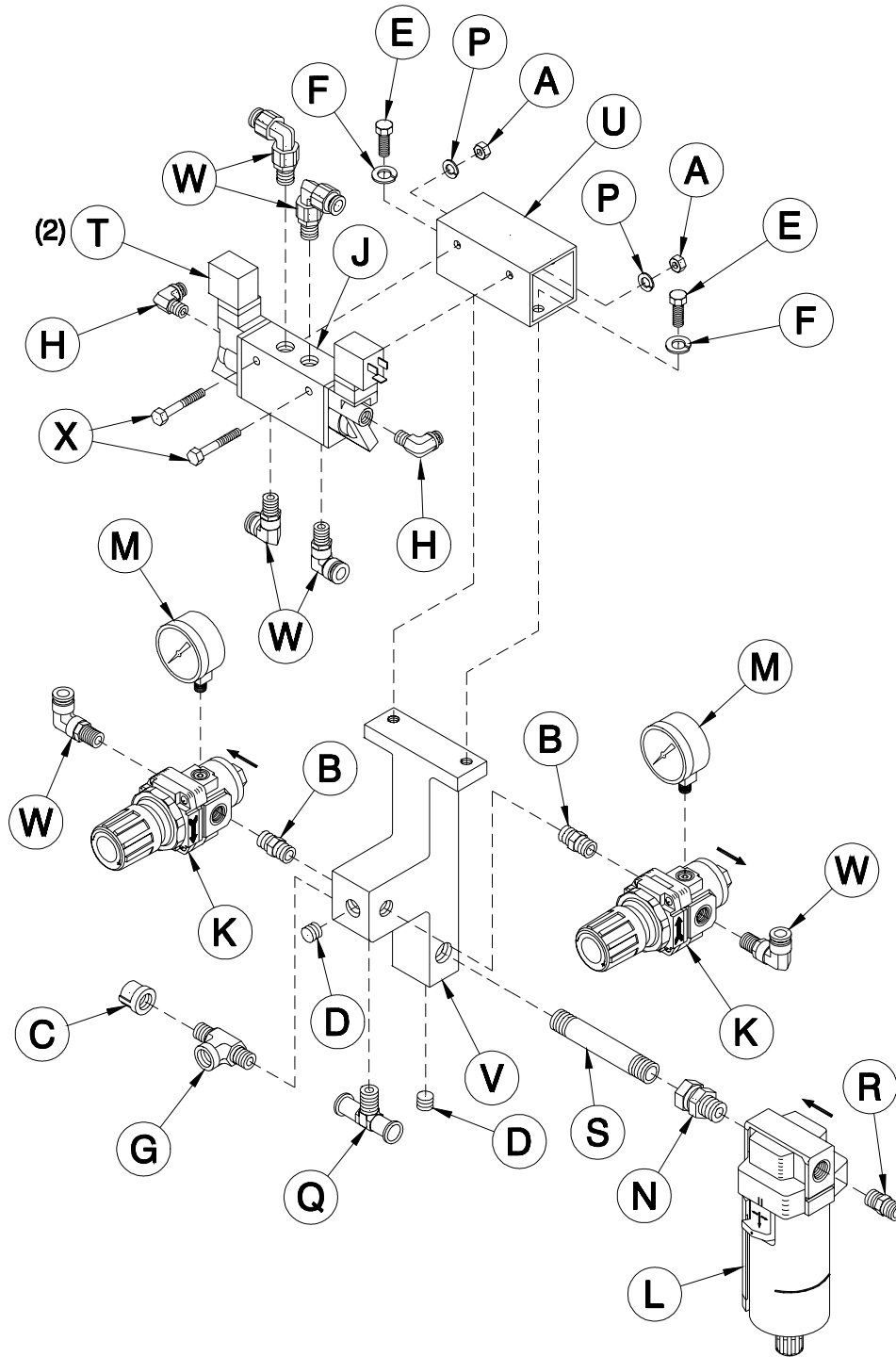

Figure 7. Air Control System, (Part No. 17756), Exploded View

TABLE 7. AIR CONTROL SYSTEM, (PART NO. 17756), PARTS

Reference Letter	Part Number	Description	Quantity
A	0385-4	Hex Nut	2
B	0561	Hex Nipple	2
C	0575	Pipe Cap	1
D	0576	Pipe Plug	2
E	1701-4	Hex Head Cap Screw	2
F	5504-3	Helical Lock Washer	2
G	6304-21	Branch Tee	1
H	6306-3	Tube Fitting	2
J	6311-109	Valve (Includes 17756-2-24)	1
K	6311-124	Regulator	2
L	6312-26	Air Filter	1
M	6314	Gauge	2
N	9457	Swivel Union	1
P	9758	Lockwasher	2
Q	17746-5	Pipe Tee	1
R	17746-7	Hex Nipple	1
S	17746-12	Pipe Nipple	1
T	17756-2-24	Coil	2
U	17756-4	Mounting Bracket	1
V	17756-7	Air Manifold	1
W	20042	Tube Fitting	6
X	IP1119	Hex Head Cap Screw	2
Not Shown	8680-3-2	Din Connector	2

Spool Replacement Kit (Part No. 17756-2-1)- Order as required from SPI.

Seal Kit (Part No. 17756-2-3)- Order as required from SPI.

Valve Modification/Rebuild Kit (Part No. 6311-109-1)- Two required per valve assembly. Spool Assembly not included. Order as required from SPI.

TABLE 8. PRIMARY HEATER, (PART NO. 17360), PARTS

Reference Letter	Part Number	Description	Quantity
A	0361-1500-220	Heating Element-220V	4
B	0371	Socket Head Cap Screw	4
C	0375C-3	Hose Nipple	1
D	0375B-2	Street Elbow	1
E	0377	Pipe Plug	41
F	0379-2	Socket Head Cap Screw	2
G	56379-1	Thermostat Mounting Bracket	1
H	0385-6	Heat Transfer Plate	1
J	0385-5	Acorn Nut	1
K	0385-4	Hex Nut	1
L	0385-3	Threaded Stud	1
M	17385-2	Mounting Bracket	1
N	6690-7-29	Thermal Limit Switch	1
P	0465	Hose Elbow	1
Q	0576	Pipe Plug	1
R	0651A-10	Lockwasher	2
S	1323	Long Male Elbow	1
T	1650-14	Wire Pig Tail	2
U	6465	Pipe Tee	1
V	9463	Socket Head Cap Screw	8
W	10350-1	Extended Hose Nipple	1
X	10356	Bracket	2
AB	17300-25-1	Thermocouple	1
AC	17357	Bushing	1
AD	17366	Preheater Wire Harness	1
AE	56300-1	R-Preheater Half	1
AF	56350-1	A-Preheater Half	1
AG	OP482-17-2	Locknut	1
AH	17385-1	Wave Spring	1
AJ	0351B-1	Stop	1
AK	OP168B-1-2	Pan Head Machine Screw	1
Not Shown	0362C-6	Replacement Microswitch	1
Not Shown	0365-9	Plastic Bushing	2
Not Shown	17358	Insulator Blanket	1

TABLE 9. PROPORTIONING PUMP, (PART NO. 17400/17450-60-SPI), PARTS

Reference Letter	Part Number	Description	Quantity
A	0213-1	Hex Nut	4
B	0377	Flush Seal Pipe Plug	6
C	0451A-60	Piston Rod	1
D	0452B-60	Cylinder	1
E	0453	O-Ring	1
F	0455	Valve Ball	2
G	0460	Screen Screw	1
H	0461	Snap Ring	1
J	0462-40	Pump Screen-40 Mesh	1
K	0463	Hex Nipple	1
L	0465	Hose Elbow	1
M	0470	Tube Nipple	1
N	0474	Cylinder Top	1
P	0476-60	Packing Set	1
Q	0477-60	Packing Support Washer	1
R	0478A-60	Packing Set	1
S	0479-60	Packing Support Washer	1
T	0480D-60/40	Packing Retainer Bolt	1
U	0481-60/48	Conical Spring	1
V	0482-60	Spring Retainer Washer	1
W	0483-7/16	Hex Head Cap Screw	1
X	0485	O-Ring	2
Y	0486-7/16	Washer	1
Z	0487A	Ball Valve	1
AA	0488-60	Packing Retainer Washer	1
AB	0562-15	Swivel Union	1
AC	6690-16-772200R	Pressure Switch	1
AE	17402	Check Valve Retainer	1
AD	17404	Tube Fitting	2
AF	17405-1	Connecting Tube	1
AG	17406	Check Valve Seat	2
AH	17407	Check Valve Seal	2
AJ	17428 17478	Resin Pump Base Iso Pump Base Assembly	1
AK	17491 0489-60	Lube Pump Assembly A - Packing Nut with Lube Cup	1
AL	56427	Tie Rod	4

POWER PACK

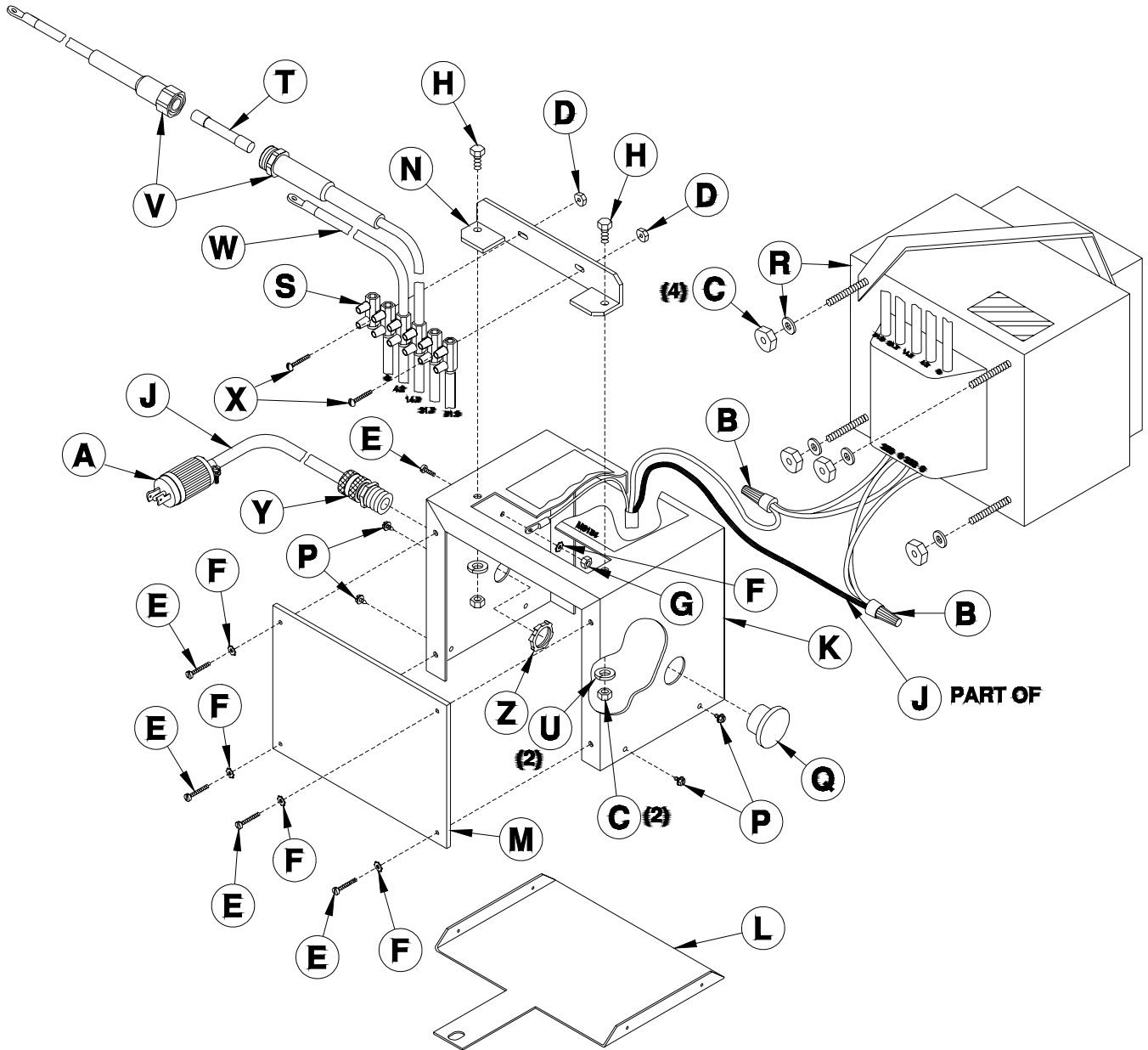

Figure 10. Power Pack, (Part No. 1276), Exploded View

TABLE 10. POWER PACK, (PART NO. 1276), PARTS

Reference Letter	Part Number	Description	Quantity
A	0251-1	Plug	1
B	0363A	Wire Nut	2
C	0385-4	Hex Nut	6
D	0651A-9	Hex Nut	2
E	0655-2	Pan Head Machine Screw	5
F	0655-4	Lockwasher	5
G	0668-3	Hex Nut	1
H	0760-3	Hex Head Cap Screw	2
J	1275B-2	Input (Power) Wire Harness (Includes Z)	1
K	1277-1	Transformer Cover Box	1
L	1277-2	Bottom Cover	1
M	1277-3	Front Cover	1
N	1277-4	Terminal Block Mounting Bracket.	1
P	1615C-4	Sheet Metal Screw	4
Q	1704-5	Hole Plug	1
R	6690-15-5	Transformer	1
S	6690-20-5-6	Terminal Block	1
T	6690-24-14	50 AMP Fuse	1
U	9758	Helical Lockwasher	2
V	14001	Hose Conn. Lead	1
W	14501-5	Hose Conn. Lead Hrn	1
X	60302	Round Head Machine Screw	2
Y	OP482-17-1	Bushing	1
Z	OP482-17-2	Locknut	1

LUBE PUMP ASSEMBLY

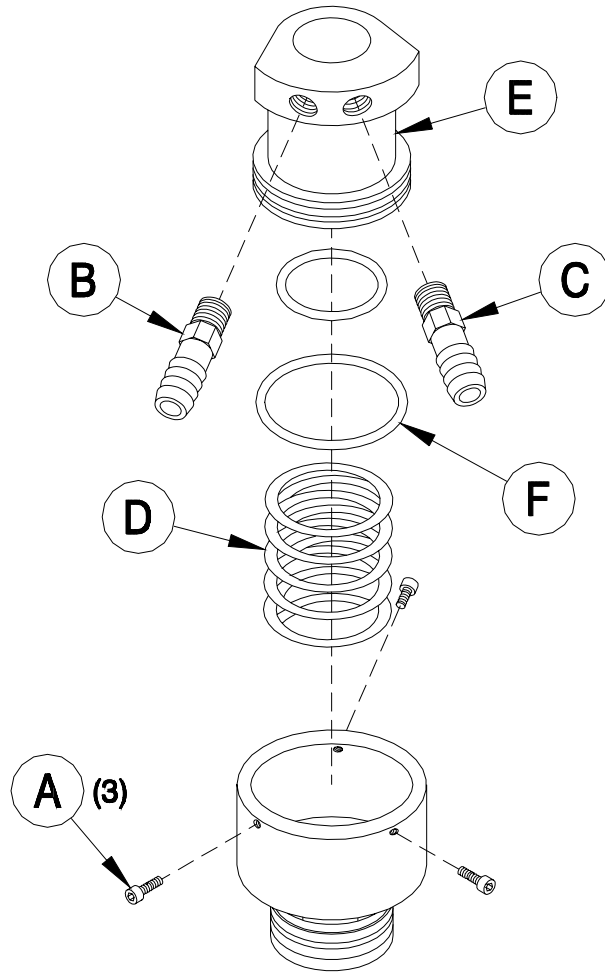

Figure 11. Lube Pump Assembly, (Part No. 17491-60), Exploded View

TABLE 11. LUBE PUMP ASSEMBLY, (PART NO. 17491-60), PARTS

Reference Letter	Part Number	Description	Quantity
A	4406-11	Socket Head Cap Screw	3
B	6310-33	Hose Barb	1
C	6310-36	Hose Barb	1
D	17491-3	Spring	1
E	29101-5	O-Ring	1
F	OP200-2-3	O-Ring	1

ELECTRICAL SCHEMATIC DIAGRAMS

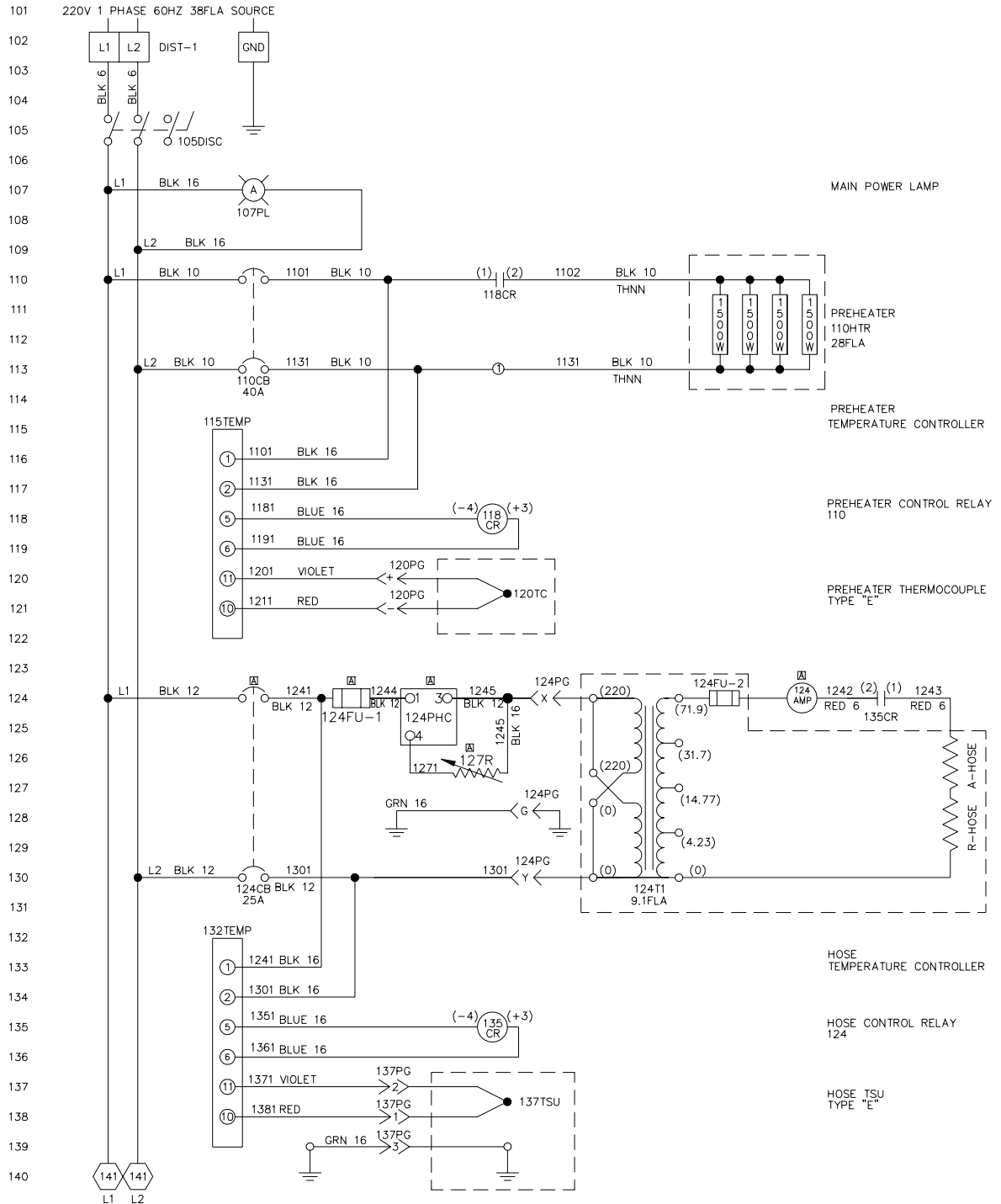

Figure 12. SPI FF 18/18 Electrical Schematic, (SD17000A-1-SPI), Sheet 1 of 2

TABLE 12. SPI FF 18/18 ELECTRICAL SCHEMATIC, (SD17000A-1-SPI), PARTS

Reference Number.	Part Number	Description	Quantity
	17715	Panel Box	1
	17706-SPI	Panel Box Cover with Hinge	1
	17707-SPI	Panel Front	1
DIST-1	6690-20-5-12	Main Power Distribution Block	1
	17650-2	Wire Terminal Lug	1
105DISC-1	6690-16-10	Switch	1
107LP	0656	Indicator Cap - White	1
	6690-19-25	Light Base	1
	6690-19-24	Bulb	1
110CB	6690-25-31	40 Amp Circuit Breaker	1
111HTR	361-1500-220	Heating Element	REF (4)
115TEMP	6690-26-23	Primary Heater Control	1
118CR	6690-1-5	Solid State Relay	1
120PG	6690-31-1-1	Thermocouple Socket	1
	6690-31-2-1	Thermocouple Plug	1
120TC	17300-25-1	Thermocouple	REF (1)
124CB	0692-1-25	25 Amp Circuit Breaker	1
124FU-1	6690-24-1	Fuse Holder	1
	6690-24-2	25 Amp Fuse	1
124PHC	6690-24-2	Phase Controller	1
124PG	0670A-1-1	Hose Socket / Wired	1
124T1	6690-15-5	Transformer	REF (1)
124FU-2	6690-24-13	In-Line Fuse Holder	REF (1)
	6690-24-14	50 Amp Fuse	REF (1)
124AMP	5616-KIT	Ammeter	1
A-HOSE		Iso Hose Assembly	REF (1)
R-HOSE		Poly Hose Assembly	REF (1)
132TEMP	6690-26-24	Hose Heat Control	1
135CR	6690-1-46	Solid State Relay	1
137PG	6690-13-2-11-4	TSU Plug	1
137TSU		TSU (Temperature Sensing Unit)	REF (1)
146T2	0689-1	Transformer	1
148FU	OP5193-3-3	1 Amp Fuse	1
	5653B	Fuse Holder	1
151SNAP	0385-1	Thermal Limit Switch	REF (1)
151CR	6690-1-14	24VAC Relay	1
157PS	6690-16-772200R	Pressure Switch	REF (1)
	6690-16-76-2	Din Connector	REF (1)
158CNT	9651-6-2	Counter	1
159PS	6690-16-772200R	Pressure Switch	REF (1)
	6690-16-76-2	Din Connector	REF (1)
160LP	6690-19-25	Light Base	1
	0660	Indicator Cap (Amber)	1
	0662A	Incandescent Bulb	1
162Q	6690-21-1	Quencharc	1
164SOL	6311-109	Valve	REF (1)
165SW1	0578A	Reversing Switch	REF (1)
166SW1	6690-16-6	DPDT Toggle Switch	1
166Q	6690-21-1	Quencharc	1
169LP	6690-19-25	Light Base	1
	0660	Indicator Light	1
	0662A	Incandescent Bulb	1

Field Number	Field Title	Description
1	Date	Enter date report is submitted.
2	Name	Enter name of person making report.
3	IM Number	Enter the Part Number of the Instruction Manual from the title page.
4	Issue Number	Enter the Issue number of the Instruction Manual from the title page. If there is no issue number, enter NONE .
5	Date of Issue	Enter the date of Issue of the Instruction Manual from the title page. If there is no issue date, enter NONE .
6	Page Number	Enter the page number containing the discrepancy
7	Discrepancy	Provide a brief description of discrepancy

NOTE: You may send a marked copy of the page as an attachment to your submittal.