

H-20/35 Pro Proportioning Unit

Operating Manual 66942-1

March 30, 2004

Issue 1

GUSMER CORPORATION®

A Subsidiary of Gusmer Machinery Group, Inc.

One Gusmer Drive

Lakewood, New Jersey, USA 08701-8055

Toll Free 1-800-367-4767 (USA & Canada)

Phone: (732) 370-9000

Fax: (732) 905-8968

Copyright 2004, GUSMER CORPORATION®

<http://www.gusmer.com>

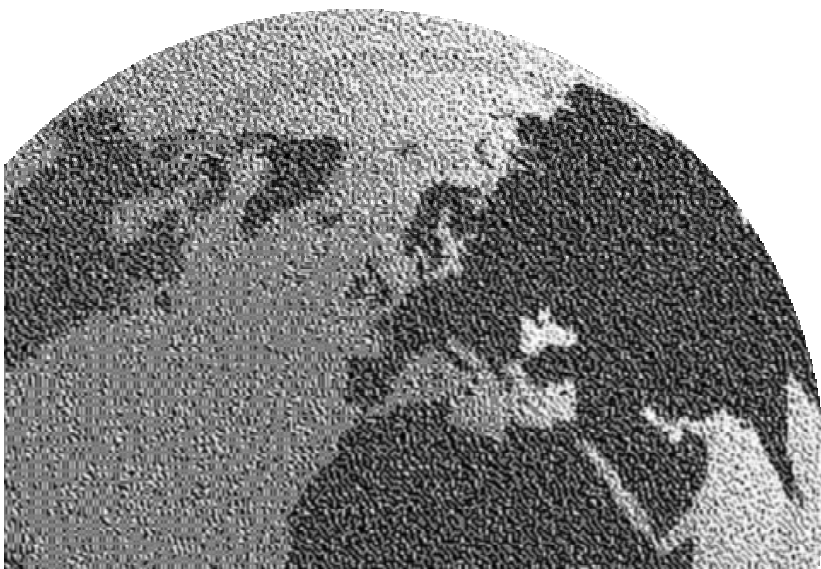

NOTICE: This manual contains important information about your GUSMER equipment. Read and retain for future reference.

NOTICE:

The equipment described in this technical manual must only be operated or serviced by properly trained individuals, thoroughly familiar with the operating instructions and limitations of the equipment. For technical service, call your local distributor. Call: 1-800-FOR-GSMR (1-800-367-4767) for the name and telephone number of your local distributor.

NOTICE:

All statements, information and data given herein are believed to be accurate and reliable but are presented without guarantee, warranty or responsibility of any kind expressed or implied. Statements or suggestions concerning possible use of GUSMER equipment are made without representation or warranty that any such use is free of patent infringement, and are not recommendations to infringe any patent. The user should not assume that all safety measures are indicated or that other measures may not be required for a particular circumstance or application.

CONTENTS

LIST OF FIGURES.....	4
WARRANTY	5
GENERAL SAFETY INFORMATION.....	6
ACCEPTABLE EQUIPMENT USES	6
OPERATIONAL SAFETY PROCEDURES	7
DESCRIPTION	8
SPECIFICATIONS	13
INITIAL MACHINE SET-UP	14
MAIN POWER INSTALLATION	15
LUBRICATION SYSTEM SET-UP.....	17
MATERIAL SUPPLY CONNECTIONS	17
HEATED HOSE INSTALLATION.....	17
AIR PURGE	21
AMPLOK® POWER CONTROL SYSTEM	21
DIGITAL TEMPERATURE CONTROLLERS	22
<i>Watlow Controller.....</i>	<i>22</i>
<i>Ogden Controller.....</i>	<i>22</i>
OPERATION.....	23
DAILY START-UP PROCEDURE.....	23
DAILY SHUT-DOWN PROCEDURE.....	24
TROUBLESHOOTING.....	25
GENERAL INFORMATION	25
PRIMARY HEATERS	26
<i>Solutions.....</i>	<i>26</i>
PROPORTIONING SYSTEM	28
<i>Solutions.....</i>	<i>29</i>
HYDRAULIC DRIVE SYSTEM.....	32
<i>Solutions.....</i>	<i>32</i>
HOSE HEAT SYSTEM.....	33
<i>Solutions.....</i>	<i>33</i>
MAINTENANCE	36
PRIMARY HEATERS	36
<i>Heating Rods.....</i>	<i>36</i>
<i>Thermocouple Replacement</i>	<i>37</i>
PROPORTIONING SYSTEM	38
<i>Proportioning Pumps.....</i>	<i>38</i>
<i>Pump Bases.....</i>	<i>38</i>
INLET STRAINER SCREEN	39

PUMP LUBRICATION SYSTEM	40
HYDRAULIC DRIVE SYSTEM	41
APPENDIX	42
INSTRUCTION MANUAL DISCREPANCY REPORT	43

LIST OF FIGURES

<i>FIGURE 1. MAJOR COMPONENTS</i>	<i>8</i>
<i>FIGURE 2. HYDRAULIC PRESSURE ADJUSTMENT.....</i>	<i>10</i>
<i>FIGURE 3. TRANSFORMER COMPARTMENT ELECTRICAL COMPONENTS.....</i>	<i>11</i>
<i>FIGURE 4. ELECTRICAL CONSOLE COMPONENTS.....</i>	<i>12</i>
<i>FIGURE 5. TYPICAL INSTALLATION</i>	<i>14</i>
<i>FIGURE 6. MAIN POWER CONNECTION.....</i>	<i>15</i>
<i>FIGURE 7. GROUND LUG.....</i>	<i>15</i>
<i>FIGURE 8. HYDRAULIC FLUID LEVEL.....</i>	<i>16</i>
<i>FIGURE 9. LUBRICANT RESERVOIR INSTALLATION.....</i>	<i>17</i>
<i>FIGURE 10. ISOLATION HOSE CONNECTIONS.....</i>	<i>18</i>
<i>FIGURE 11. HOSE CONNECTION STEP (A).....</i>	<i>18</i>
<i>FIGURE 12. HOSE CONNECTION STEP (B & C).....</i>	<i>18</i>
<i>FIGURE 13. HOSE CONNECTION STEP (D)</i>	<i>18</i>
<i>FIGURE 14. HOSE CONNECTION STEP (E & F).....</i>	<i>19</i>
<i>FIGURE 15. TEMPERATURE SENSING UNIT (TSU) CONNECTION</i>	<i>20</i>
<i>FIGURE 16. WATLOW TEMPERATURE CONTROLLER</i>	<i>22</i>
<i>FIGURE 17. OGDEN TEMPERATURE CONTROLLER</i>	<i>22</i>
<i>FIGURE 18. PRIMARY HEATER</i>	<i>26</i>
<i>FIGURE 19. PRIMARY HEATER CIRCUIT BREAKERS</i>	<i>27</i>
<i>FIGURE 20. PROPORTIONING SYSTEM</i>	<i>28</i>
<i>FIGURE 21. HYDRAULIC MANIFOLD.....</i>	<i>31</i>
<i>FIGURE 22. MOTOR CIRCUIT PROTECTOR.....</i>	<i>32</i>
<i>FIGURE 23. HOSE HEAT CIRCUIT BREAKER.....</i>	<i>33</i>
<i>FIGURE 24. AMPLOK[®] HOSE HEAT CONTROLLER.....</i>	<i>34</i>
<i>FIGURE 25. THERMOCOUPLE COMPONENTS.....</i>	<i>37</i>
<i>FIGURE 26. Y STRAINER COMPONENTS</i>	<i>39</i>



WARRANTY

Gusmer Corporation (Gusmer) provides a limited warranty to the original purchaser (Customer) of Gusmer manufactured parts and equipment (Product) against any defects in material or workmanship for a period of one year from the date of shipment from Gusmer facilities.

In the event Product is suspected to be defective in material or workmanship, it must be returned to Gusmer, freight prepaid. If Product is found to be defective in material or workmanship, as determined solely by Gusmer, Gusmer will issue full credit to Customer for the freight charges incurred in returning the defective Product, and either credit will be issued for the replacement cost of the Product or a replacement part will be forwarded no-charge, freight prepaid to Customer.

This warranty shall not apply to Product Gusmer finds to be defective resulting from: installation, use, maintenance, or procedures not accomplished in accordance with our instructions; normal wear; accident; negligence; alterations not authorized in writing by Gusmer; use of "look alike" parts not manufactured or supplied by Gusmer; or Product used in conjunction with any other manufacturer's pumping or proportioning equipment. For such Product, a written estimate will be submitted to the Customer at a nominal service charge, itemizing the cost for repair. Disposition of Product will be done in accordance with the terms stated on the written estimate.

The warranty provisions applied to product that are not manufactured by Gusmer will be solely in accordance with the warranty provided by the original manufacturer of the product.

GUSMER MAKES NO WARRANTY WHATSOEVER AS TO THE MERCHANTABILITY OF, OR SUITABILITY FOR, ITS PRODUCT TO PERFORM ANY PARTICULAR PURPOSE. CREDIT FOR, OR REPLACEMENT OF, PRODUCT DEFECTIVE IN MATERIAL OR WORKMANSHIP SHALL CONSTITUTE COMPLETE FULFILLMENT OF GUSMER OBLIGATIONS TO CUSTOMER. NO OTHER WARRANTY, EXPRESS OR IMPLIED ON ANY PRODUCT IT MANUFACTURES AND/OR SELLS, WILL BE RECOGNIZED BY GUSMER UNLESS SAID WARRANTY IS IN WRITING AND APPROVED BY AN OFFICER OF GUSMER.

Under no circumstances shall Gusmer be liable for loss of prospective or speculative profits, or special indirect, incidental or consequential damages. Further, Gusmer shall have no liability for any expenses including, but not limited to personal injury or property damage resulting from failure of performance of the product, use of the product, or application of the material dispensed through the product. Any information provided by Gusmer that is based on data received from a third source, or that pertains to product not manufactured by Gusmer, while believed to be accurate and reliable, is presented without guarantee, warranty, or responsibility of any kind, express or implied.

Gusmer through the sale, lease, or rental of Product in no way expresses or implies a license for the use of, nor encourages the infringement of any patents or licenses.

To ensure proper validation of your warranty, please complete the warranty card and return it to Gusmer within two weeks of receipt of equipment.

Revised 09/02



GENERAL SAFETY INFORMATION

It is necessary to understand and follow the instructions in this manual to ensure proper and safe operation of the equipment.

As with most mechanical equipment, certain safety precautions must be taken when the equipment discussed in this manual is operated or serviced. Severe bodily injury or damage to equipment and property may result if the instructions and precautions listed throughout this manual are not followed.

Needless to say, sufficient guidelines cannot be developed to eliminate the need for good common sense in the use and servicing of this equipment, and in the use and application of the products, this equipment has been designed to process. Users of this equipment must therefore make their own determination as to the suitability of the information contained in this manual to their specific operation and requirements. There should be no assumption made that the safety measures and instructions contained herein are all-inclusive, and that other safety measures may not be required for specific use or application.

The following safety guidelines are generally applicable to the safe and efficient use of the equipment.

Acceptable Equipment Uses

The equipment is designed for the dispensing of polyurethane foams, two-component coating systems, such as polyureas, and some two-component epoxy systems. Under no circumstances should any acid or corrosive chemicals be used in the unit. Consult GUSMER if there is any doubt about the compatibility of the chemical system to be used in this equipment.

Any use of this equipment other than as indicated above constitutes misuse unless express written approval is obtained from GUSMER.

Your Gusmer equipment incorporates design parameters, features, and functionality developed in over 40 years of plural component equipment design and manufacture. It is manufactured under the stringent standards of ISO 9001, and is backed by the Gusmer Warranty included herein.

The use of genuine Gusmer replacement parts is recommended for your equipment. Substitution of parts not designed, manufactured, or recommended by Gusmer may result in reduced performance of, and/or damage to, your Gusmer equipment. Any alterations to, or substitutions for, genuine Gusmer parts shall void the provisions of the Gusmer Warranty.

Operational Safety Procedures

This safety information will not be repeated in the text of this manual. The symbols pertaining to this information will appear where appropriate to alert the operator to potential hazards.

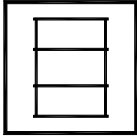

Solvents and Chemicals

WARNING: THE SOLVENTS AND CHEMICALS USED WITH THIS EQUIPMENT EXPOSE THE OPERATOR TO CERTAIN HAZARDS. ADEQUATE PERSONAL PROTECTIVE MEASURES MUST BE TAKEN SO AS TO AVOID EXCEEDING THE THRESHOLD LIMIT VALUE (TLV) OF THE PRODUCTS BEING USED, AS ESTABLISHED BY THE OCCUPATIONAL SAFETY AND HEALTH ADMINISTRATION (OSHA) OR OTHER QUALIFIED AGENCY. OBTAIN INFORMATION CONCERNING PERSONAL PROTECTION AND PROPER HANDLING FROM THE SUPPLIER OF SUCH SOLVENTS AND CHEMICALS.

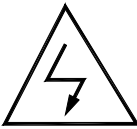

High Voltage

WARNING: TO PREVENT SERIOUS BODILY INJURY FROM ELECTRICAL SHOCK, NEVER OPEN THE ELECTRIC CONSOLES OR OTHERWISE SERVICE THIS EQUIPMENT AND/OR EQUIPMENT USED WITH IT BEFORE SWITCHING OFF THE MAIN POWER DISCONNECT AND SHUTTING OFF AND LOCKING OUT SUPPLY VOLTAGE AT THE SOURCE. THE ELECTRICAL SERVICE MUST BE INSTALLED AND MAINTAINED BY A QUALIFIED ELECTRICIAN.



High Pressure

WARNING: THIS EQUIPMENT HAS OR IS USED WITH EQUIPMENT THAT HAS HYDRAULIC AND CHEMICAL COMPONENTS CAPABLE OF PRODUCING UP TO 3500 PSI. TO AVOID SERIOUS BODILY INJURY FROM INJECTION OF FLUID, NEVER OPEN OR SERVICE ANY CONNECTIONS OR COMPONENTS WITHOUT BLEEDING ALL PRESSURES TO ZERO.

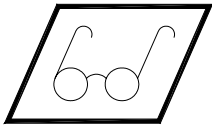

Personal Protective Equipment

WARNING: TO AVOID SERIOUS BODILY INJURY, PROPER PROTECTIVE GEAR, APPROPRIATE FOR THE TASK BEING ACCOMPLISHED, MUST BE WORN WHEN OPERATING, SERVICING, OR BEING PRESENT IN THE OPERATIONAL ZONE OF THIS EQUIPMENT. THIS INCLUDES, BUT IS NOT LIMITED TO, EYE AND FACE PROTECTION, GLOVES, SAFETY SHOES, AND RESPIRATORY EQUIPMENT AS REQUIRED TO PROVIDE PERSONAL PROTECTION FROM SOLVENTS AND CHEMICALS; HIGH PRESSURE RELEASES; HIGH TEMPERATURES; ELECTRIC SHOCK; AND OTHER HAZARDS ASSOCIATED WITH HYDRAULIC/ELECTRO-MECHANICAL EQUIPMENT. REFER TO THE APPROPRIATE WARNINGS ON THIS PAGE FOR FURTHER INFORMATION.

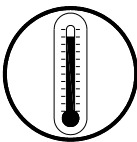

High Temperature

WARNING: THIS EQUIPMENT HAS OR IS USED WITH EQUIPMENT THAT HAS HIGH TEMPERATURE COMPONENTS SUCH AS PRIMARY HEATERS AND HEATED HOSES. TO PREVENT SERIOUS BODILY INJURY FROM HOT FLUID OR HOT METAL, NEVER ATTEMPT TO SERVICE THE EQUIPMENT BEFORE ALLOWING IT TO COOL.



Warning

WARNING: FAILURE TO READ AND FOLLOW THE INFORMATION ASSOCIATED WITH THIS SYMBOL MAY RESULT IN PERSONAL INJURY AND/OR DAMAGE TO THE EQUIPMENT.

DESCRIPTION

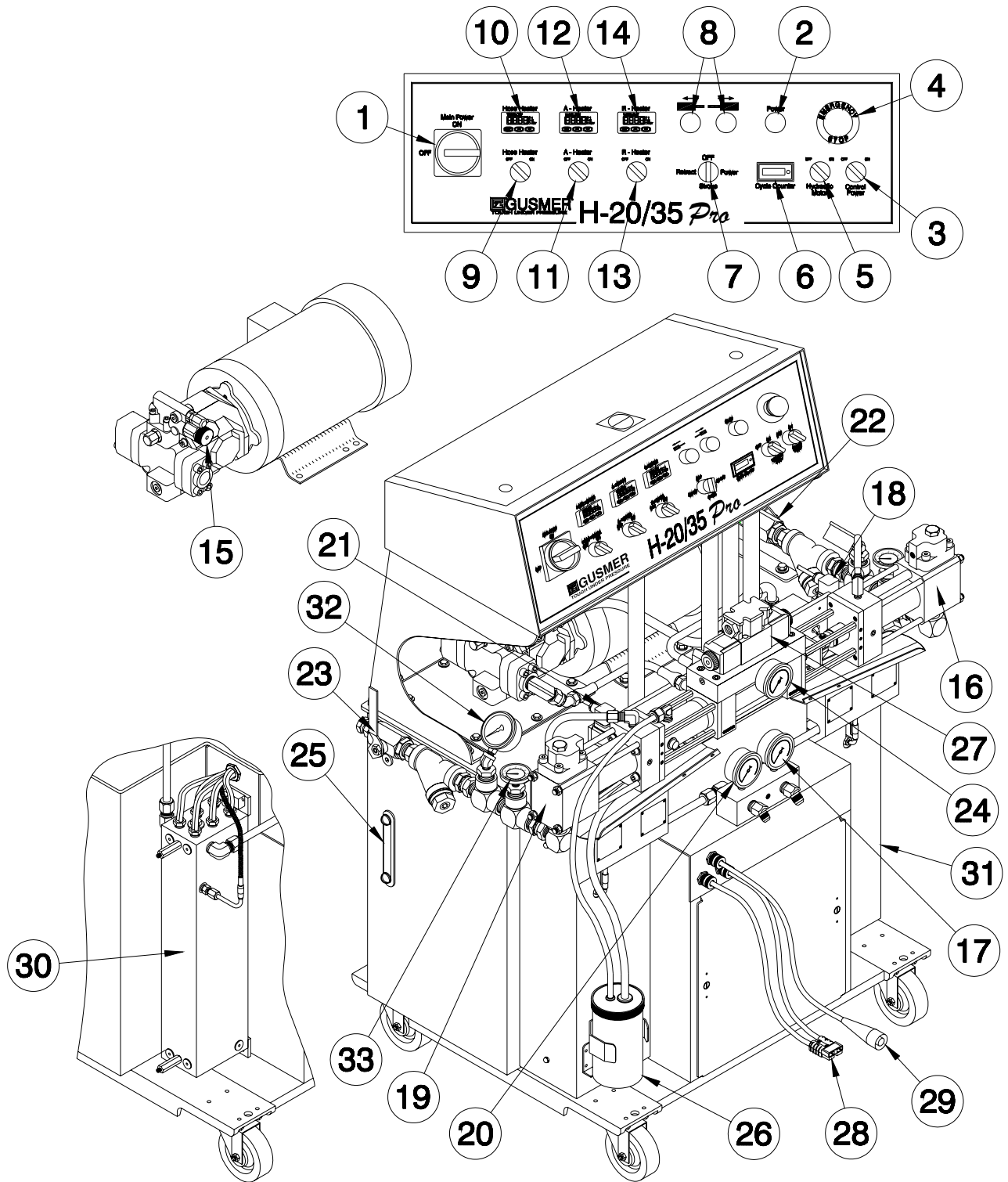

Figure 1. Major Components

See H-20/35 Pro Parts Identification Manual (P/N 66942-ID) for complete part number information.



1. **MAIN POWER DISCONNECT**- Controls power to all circuits. Must be ON for any function of the proportioning unit to operate. The disconnect can be locked in the OFF position for OSHA required lockout/tagout during machine maintenance.

WARNING: *INCOMING POWER LEADS FROM THE MAIN ELECTRICAL SOURCE REMAIN ENERGIZED WHEN THE MAIN POWER DISCONNECT IS OFF. TO FULLY DE-ENERGIZE THE ELECTRICAL CONSOLE, SWITCH OFF AND LOCK OUT INCOMING POWER AT THE SOURCE.*

2. **MAIN POWER LIGHT (WHITE)**- Lights up when the main disconnect switch is in the ON position and the control power transformer is operational.
3. **CONTROL POWER SWITCH**- Turns the unit's 120VAC control power circuit on and off. In the ON position, the amber light within the switch lights up. Removal of control power stops all machine operation including motion and heating.
4. **EMERGENCY STOP SWITCH**- Interrupts the units control power circuit to stop all motion and heating. Switch mechanically locks in the stop position. Turn the switch clockwise to reset it and restore normal operation.
5. **MOTOR CONTROL SWITCH**- Controls power to the electric motor circuit. In the ON position, the green light within the switch lights up.
6. **COUNTER**- Records the cycle count of the proportioning pumps. One cycle equals two strokes (one in each direction).
7. **PUMP SWITCH**- Controls operation of the proportioning pump hydraulic drive cylinder.
 - **OFF**- Deactivates the pump system and shuts off the hydraulic directional valve. Hydraulic pressure cannot be generated in this position.
 - **NORMAL**- Must be in this position for the pump system to operate. This position is used for all normal operation of the pump system, including pressurizing of the system and dispensing of chemical.
 - **RETRACT**- Use during any period of machine inactivity. The pump system is energized so that the isocyanate pump shaft is retracted into the pump cylinder. Shields the isocyanate pump shaft from moisture to limit crystallization during periods of machine inactivity.
8. **PUMP DIRECTIONAL INDICATOR LIGHTS**- Indicate the direction of proportioning pump travel. Both lights will be off when the pump switch is in the OFF position or when the chemical pump pressure exceeds the setting of the overpressure safety switches.
9. **HOSE HEATER SWITCH**- Energizes the hose heat system circuit. In the ON position, the green light within the switch lights up.
10. **HOSE HEAT TEMPERATURE CONTROLLER**- Digital display of controller will be energized when control power switch is activated. The hose heater switch must be in the ON position before heating process will begin. (See Digital Temperature Controllers on page 22.)
11. **A- (ISOCYANATE) PRIMARY HEATER SWITCH**- Energizes the A-primary heater system circuit. In the ON position, the green light within the switch lights up.
12. **A- (ISOCYANATE) PRIMARY HEATER TEMPERATURE CONTROLLER**- Digital display of controller will be energized when control power switch is

activated. The A- primary heater switch must be in the ON position before heating process begins. (See Digital Temperature Controllers on page 22.)

13. **R- (RESIN) PRIMARY HEATER SWITCH-** Energizes the R-primary heater system circuit. In the ON position, the green light within the switch lights up.
14. **R- (RESIN) PRIMARY HEATER TEMPERATURE CONTROLLER-** Digital display of controller will be energized when control power switch is activated. The R- primary heater switch must be in the ON position before heating process will begin. (See Digital Temperature Controllers on page 22.)

15. **HYDRAULIC PRESSURE CONTROL-** Controls the hydraulic pressure available to the hydraulic drive system. Turn the adjustment knob clockwise to increase pressure, counterclockwise to decrease pressure. (See Figure 2.)

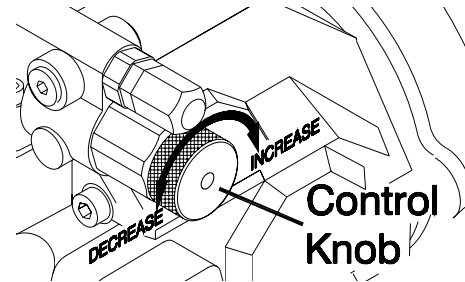

Figure 2. Hydraulic Pressure Adjustment

16. **R- (RESIN) PROPORTIONING PUMP-** Draws in and dispenses a fixed volume of resin material for delivery to the mixing chamber of the spray gun or pour head.
17. **R- (RESIN) PRESSURE GAUGE-** Indicates the pressure in the resin proportioning system.
18. **R- (RESIN) OVER-PRESSURE SAFETY SWITCH-** Factory set to turn off the hydraulic drive system when the resin proportioning pump exceeds the designed operating pressure limit.
19. **A- (ISOCYANATE) PROPORTIONING PUMP-** Draws in and dispenses a fixed volume of isocyanate material for delivery to the mixing chamber of the spray gun or pour head.
20. **A- (ISOCYANATE) PRESSURE GAUGE-** Indicates the pressure in the isocyanate proportioning system.
21. **A- (ISOCYANATE) OVER-PRESSURE SAFETY SWITCH-** Factory set to turn off the hydraulic drive system when the isocyanate proportioning pump exceeds the designed operating pressure limit.
22. **R- (RESIN) INLET SUPPLY BALL VALVE-** Allows delivery of resin to the proportioning unit.
23. **A- (ISO) INLET SUPPLY BALL VALVE-** Allows delivery of isocyanate to the proportioning unit.
24. **HYDRAULIC PRESSURE GAUGE-** Indicates the pressure in the hydraulic drive system.
25. **HYDRAULIC TANK LEVEL GAUGE-** Shows the level of oil in the tank.

- 26. **LUBE PUMP SYSTEM** (*Iso side only*)- Continuously circulates pump lube to prevent the crystallization of isocyanate on the pump shaft.
- 27. **HYDRAULIC DIRECTIONAL VALVE**- Controls the direction of hydraulic flow.
- 28. **HOSE HEAT POWER-LOCK CONNECTION**- Provides power to the heated hoses.
- 29. **TSU HARNESS**- Carries the electrical signal from the TSU sensor in the isocyanate hose to the digital hose temperature controller.
- 30. **A- (ISOCYANATE) PRIMARY HEATER**- Heats the isocyanate to the required dispensing temperature.
- 31. **R- (RESIN) PRIMARY HEATER**- (*Located behind cover*) Heats the resin to the required dispensing temperature.
- 32. **INLET PRESSURE GAUGE**- (*Both sides*) Indicates the chemical supply pressure at the proportioner inlet.
- 33. **INLET TEMPERATURE GAUGE**- (*Both sides*) Indicates the chemical supply temperature at the proportioner inlet.

- 34. **HOSE HEAT SECONDARY CIRCUIT BREAKER**- Fifty-amp circuit breaker that protects the hose heat system by limiting current to the hose heat element. Must be ON for the heated hoses to function.

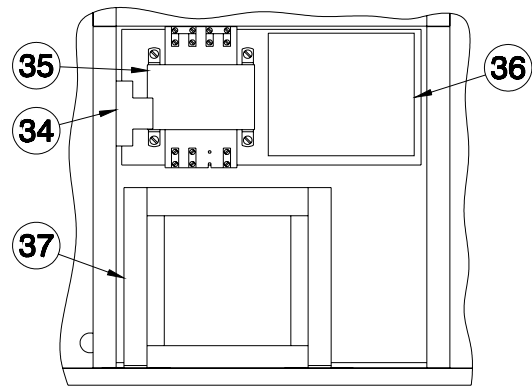

Figure 3. Transformer Compartment Electrical Components

- 35. **CONTROL CIRCUIT TRANSFORMER**- Steps down the incoming line voltage to 120 VAC for use by the control circuit system.
- 36. **AMPLOK CONTROLLER**- Automatically manages the electrical current supplied to the hose heat system.
- 37. **HOSE HEAT SYSTEM TRANSFORMER**- Provides selectable low-voltage outputs for heating various chemical hose lengths.
- 38. **CONTROL MAIN TERMINAL BLOCK**- Termination/distribution point for control system component wires.
- 39. **CONTROL TRANSFORMER SECONDARY CIRCUIT BREAKER**- Provides over-current protection for the control transformer secondary 120 volt AC output.
- 40. **MASTER RELAY**- Controls distribution of 120 Volt AC to control power system. The control power switch energizes the relay.
- 41. **A- (ISOCYANATE) HEATER CONTROL RELAY**- Controls distribution of line voltage to A-primary heater circuit. The A-primary heater temperature controller controls the relay.

- 42. **R- (RESIN) PRIMARY HEATER CONTROL RELAY-** Controls distribution of line voltage to R-primary heater circuit. The R-primary heater temperature controller controls the relay.
- 43. **MOTOR CONTACTOR-** Supplies line voltage to electric motor. The hydraulic motor switch controls the contactor.

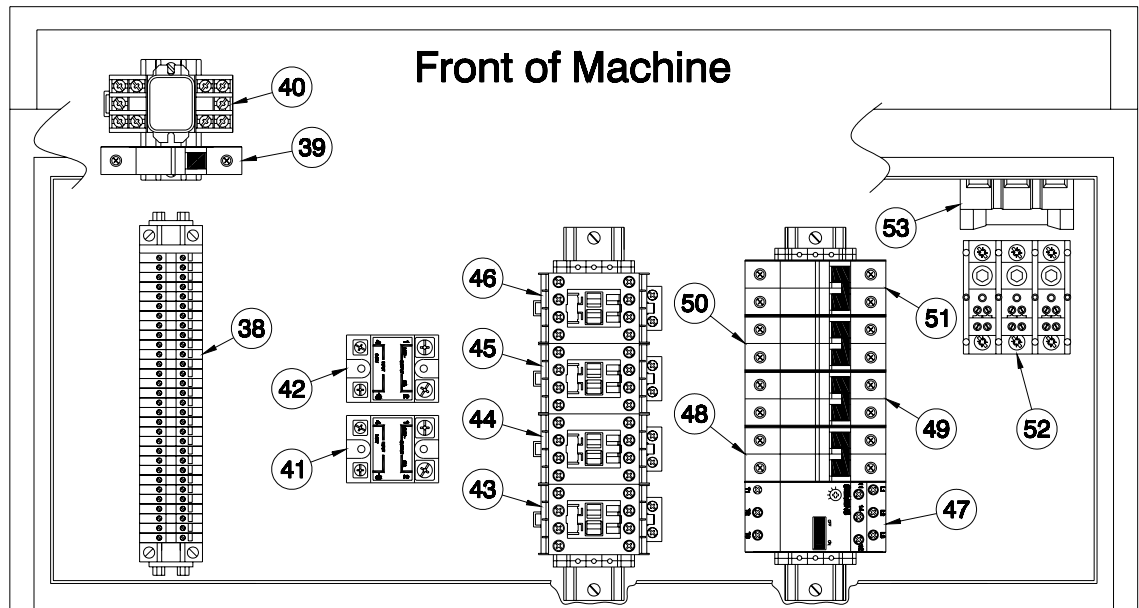

Figure 4. Electrical Console Components

- 44. **A- (ISOCYANATE) PRIMARY HEATER CONTACTOR-** Supplies line voltage to the A-primary heater. The A- primary heater switch controls the contactor.
- 45. **R- (RESIN) PRIMARY HEATER CONTROL CONTACTOR-** Supplies line voltage to R-primary heater. The R-primary heater switch controls the contactor.
- 46. **HOSE HEAT CONTACTOR-** Supplies line voltage to hose heat system. The hose heater switch controls the contactor.
- 47. **MOTOR CIRCUIT PROTECTOR-** Provides thermal overload and over-current protection for the hydraulic motor circuit.
- 48. **A- (ISOCYANATE) HEATER CIRCUIT BREAKER-** Provides over-current protection for the A-primary heater circuit.
- 49. **R- (RESIN) PRIMARY HEATER CIRCUIT BREAKER-** Provides over-current protection for the R-primary heater circuit.
- 50. **HOSE HEAT TRANSFORMER PRIMARY CIRCUIT BREAKER-** Provides over-current protection for the hose heat transformer primary circuit.
- 51. **CONTROL TRANSFORMER PRIMARY CIRCUIT BREAKER-** Provides over-current protection for the control transformer primary circuit.
- 52. **POWER DISTRIBUTION BLOCK-** Provides power distribution point for incoming line voltage to the circuit breaker bank.
- 53. **MAIN POWER DISCONNECT (Inside View)-** Provides termination point for incoming power. Disconnects incoming power from machine circuits.



SPECIFICATIONS

MATERIAL SUPPLY: Required chemical viscosity: 250-1500 centipoise (cP). Consult your chemical supplier about material temperatures required to maintain correct viscosity.

Protect the chemical supply from atmospheric moisture with a blanket of dry nitrogen or desiccated air.

Resin Inlet: 3/4" NPT (FE) swivel

Isocyanate Inlet: 1/2" NPT (FE) swivel

Material supply pressure: 400 psi maximum (27 Bars)

HYDRAULIC SYSTEM: Reservoir Capacity: 25 gallons (94.6 Liters) See Appendix for recommended hydraulic fluids.

Recommended operating temperature: 120°F (48°C)

Maximum operating temperature: 160°F (71°C)

Operating pressure: 250-1500 psi

ELECTRICAL: 100 amps @ 1 x 230 volts, 60 Hertz, AC.
 60 amps @ 3 x 230 volts, 60 Hertz, AC.
 74 amps @ 3 x 230 volts, 60 Hertz, AC (9KW heaters).
 48 amps @ 3 x 380 volts, 60 Hertz, AC.
 62 amps @ 3 x 380 volts, 60 Hertz, AC (9KW heaters).
 30 amps @ 3 x 460 volts, 60 Hertz, AC.
 37 amps @ 3 x 460 volts, 60 Hertz, AC (9KW heaters).

WEIGHT: Empty: 385 pounds (175 kilograms)
 Serviced: 735 pounds (333 kilograms)

DIMENSIONS: Height: 47 inches (119 centimeters)
 Width: 40 inches (102 centimeters)
 Depth: 22 inches (56 centimeters)

PROPORTIONING PUMPS: Static Pressure: H-20 - 2000 psi maximum (138 bars)
 H-25 - 2500 psi maximum (172 bars)
 H-35 - 3500 psi maximum (240 bars)

Output: H-20 - 38 lb./min. maximum (17.3 kg/min) *
 H-25 - 34 lb./min. maximum (15.4 kg/min) *
 H-35 - 24 lb./min. maximum (10.8 kg/min.) *

INLET FILTER: 80 Mesh Standard (Optional - 60/40 Mesh)

PRIMARY HEATER: 6000 Watts per heater at 220 Volts (Optional 9000 Watts per heater at 220 Volts)

HOSE LENGTH: 410 feet (125 meters) maximum for heating purposes

* Theoretical: actual results will vary with operating conditions.

INITIAL MACHINE SET-UP

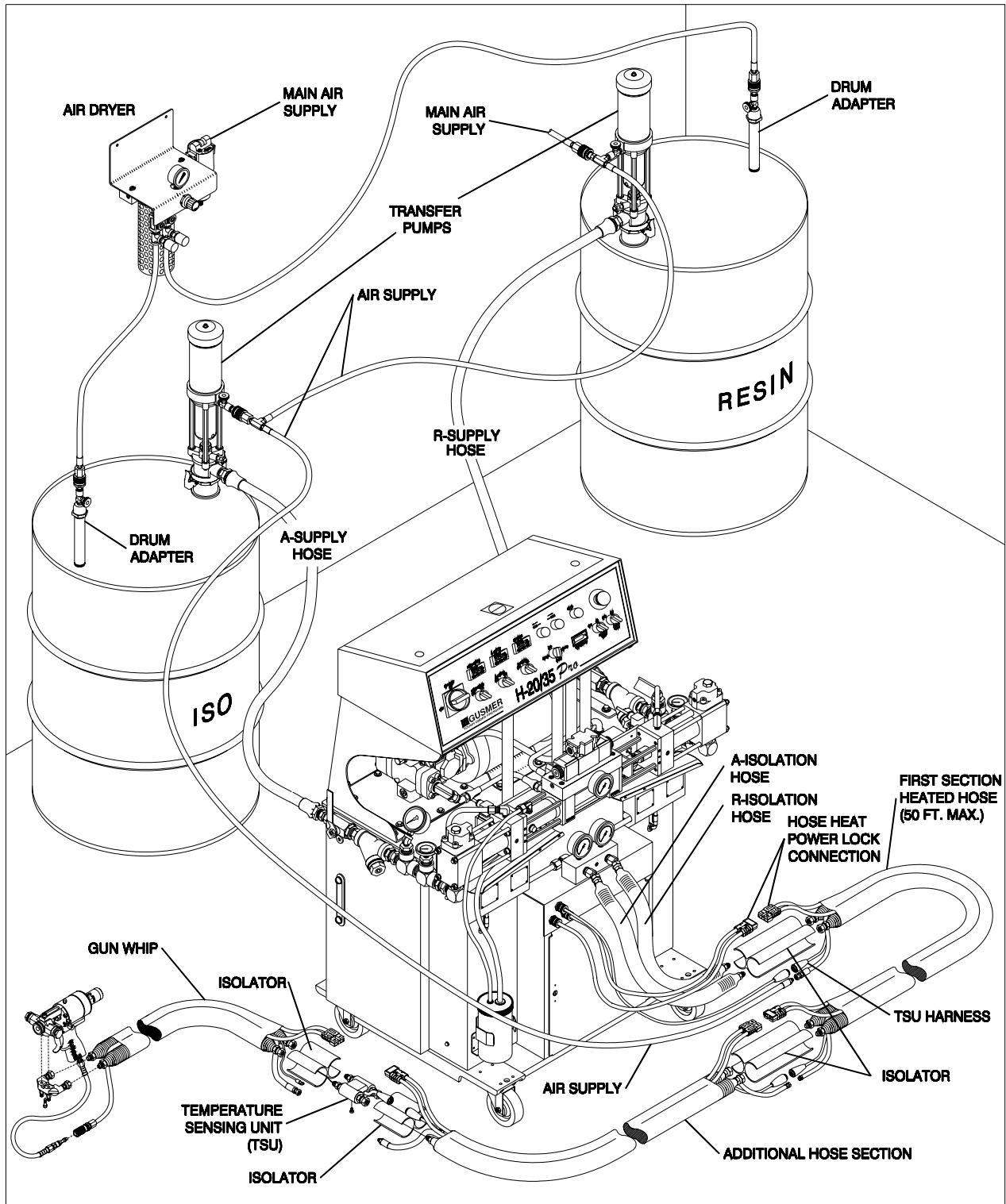

Figure 5. Typical Installation

** Consult Gusmer Sales for the correct hose sizes for your application.*

The Accessory Package included with the unit contains the following parts required for set-up:

- **Tape Roll**
- **Isolator**
- **(2) 3/8 Hose Adapters**
- **Isolation Hoses**
Blue – Resin
Red – Isocyanate
- **Temperature Sensing Unit (TSU)**
- **Warranty Card**
- **Hose Jumper Plug**
- **Parts Identification Manual**
- **Binder**

* Refer to Figure 5 for additional parts required for set-up.

IMPORTANT: Complete and return the Warranty Validation Card within 2 weeks of receipt of equipment.

Main Power Installation

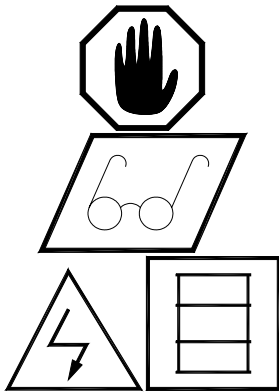

NOTE:
The dashed lines in Figure 6 indicate the additional wire found on three-phase units.

WARNING: BEFORE PROCEEDING, BE SURE THAT INCOMING POWER IS DISCONNECTED AND LOCKED OUT AT THE SOURCE.

IMPORTANT: The main power source must be capable of meeting the electrical requirements specified on the nameplate of the proportioning unit and an accessible quick disconnect provided.

1. Open the electrical console and connect the main power cord as follows: (See Figure 6 and Figure 7.)
 - a) Feed the power cord through the strain relief in the bottom of the console.
For Single-Phase Units, connect the power leads to L1 and L2.
For Three-Phase units, connect the power leads to L1, L2, and L3.
For 380 Volt Three-Phase units, also connect the neutral wire to the blue neutral terminal block on the circuit breaker rail.
 - b) Connect the ground wire to the ground lug located inside the console near the strain relief opening.

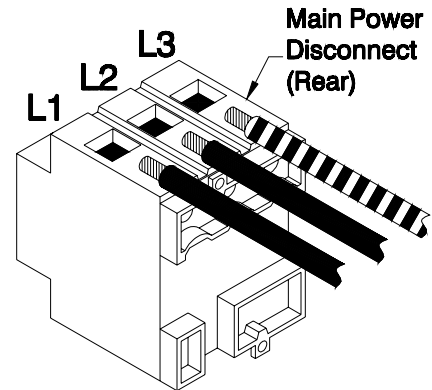

Figure 6. Main Power Connection

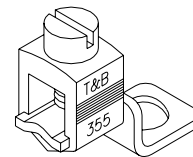

Figure 7. Ground Lug

2. Fill the hydraulic reservoir through the vented filler neck with approximately 34 gallons of hydraulic fluid. See the list in the Appendix on page 42 for the recommended types of fluid.

IMPORTANT: DO NOT overfill the reservoir. The level indicator should read approximately 1/2 full with fluid.

3. Check the hydraulic pump to ensure that it is full with hydraulic fluid as follows: (See Figure 8).
 - a) Disconnect the hydraulic hose from the 90° fitting on the top of the pump.
 - b) Remove the 90° fitting from the top of the pump and determine that the fluid level is to the top of the threaded hole. Add fluid as required and reattach the fitting and hose.

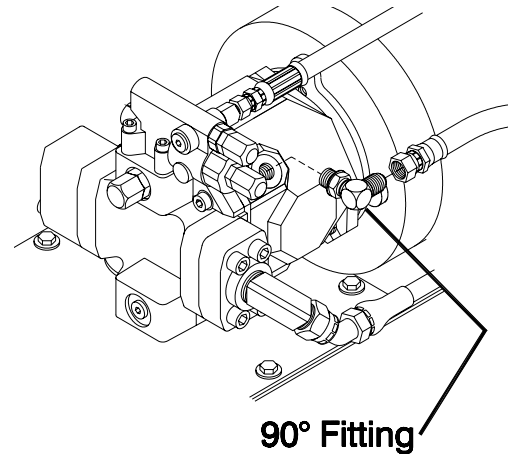
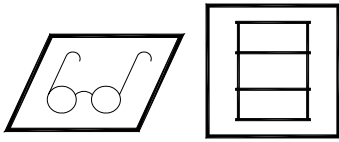

Figure 8. Hydraulic Fluid Level

4. **Single-phase units go to Step 5.**
Three-phase units only: Check that the electric motor is correctly rotating clockwise. A counterclockwise rotation indicates that the incoming power leads are incorrectly wired to the unit. (See step 1 on page 15)
 To check for correct rotation, proceed as follows:
 - a) Check that the pump, hose heat, A-primary heater and R-primary heater switches are in the OFF position and the main power source is ON.
 - b) Turn ON the red main disconnect. The white pilot light will light up.
 - c) Turn ON the amber control power switch. The light within the switch and the temperature controllers will light up.
 - d) While observing the fan on the end of the electric motor, turn the hydraulic motor switch ON and OFF. The fan's direction of rotation must be clockwise. If not rotating clockwise, turn OFF the red main disconnect switch and disconnect and lock out the incoming power at the source. Open the electric console and switch any two of the three main power leads on the main disconnect. (See Figure 6 on page 15.) Recheck the direction of rotation and check hydraulic connections for leaks.
5. Set up the chemical supply, air supply and moisture control systems as required. See the system instructions for proper set-up and operating procedures.
6. Properly ground all auxiliary equipment. If not grounded, the high velocity flow of fluid can create a static charge, which may spark and cause fire or explosion. Certain solvents that are commonly in use with this equipment are flammable and may present a flash danger to the operator.
 - a) Ground the material supply (transfer pumps/day tanks).
 - b) The 2:1 transfer pump has a ground lug. Ground the pump in accordance with the instructions provided with the pump.
 - c) Check that the proportioning unit ground at the main electrical source is installed in accordance with the National Electrical Code. If a generator will be powering the unit, consult with your electrician about additional grounding measures that may be required.

Lubrication System Set-up



1. Prepare the isocyanate pump lubrication system for use as follows:
 - a) Fill the lubricant reservoir with Gusmer pump lubricant.
 - b) Thread the reservoir onto the reservoir cap assembly and place it into the bracket (see Figure 9).
 - c) Push the larger diameter supply tube approximately 1/3 of the way down into the reservoir.
 - d) Push the smaller diameter return tube down into the reservoir until it reaches the bottom.

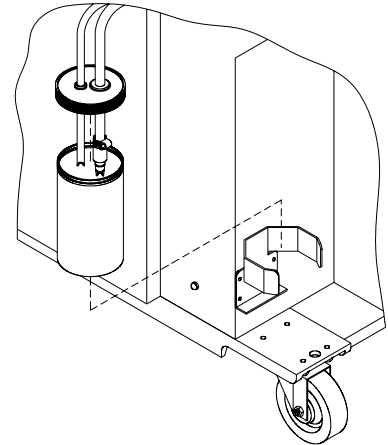
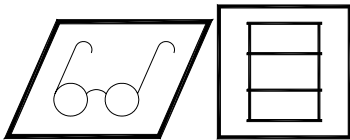

Figure 9. Lubricant Reservoir Installation

IMPORTANT: The larger diameter supply tube must be at the upper level of the reservoir and the return tube at the lower level of the reservoir. This ensures that any isocyanate crystals will settle to the bottom of the reservoir and not return to the isocyanate pump shaft.

The lubrication system is now ready for operation. No priming is required.

Material Supply Connections



Connect the material supply to the inlets of the proportioning unit as follows:

1. Ensure that the A- and R- inlet ball valves on the proportioning unit are closed.
2. Connect and tighten the R- (resin) supply hose to the 3/4 FPT swivel fitting on the R- inlet ball valve.
3. Connect and tighten the A- (isocyanate) supply hose to the 1/2 FPT swivel fitting on the A- inlet ball valve.

Heated Hose Installation

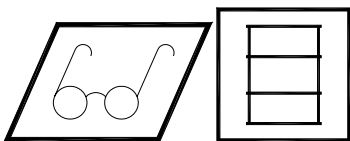

WARNING: TO MAKE PROPER AND SAFE HOSE CONNECTIONS, READ AND UNDERSTAND FOLLOWING:

ISOCYANATE HOSES ARE COLOR-CODED RED AND RESIN HOSES ARE COLOR-CODED BLUE FOR POSITIVE IDENTIFICATION. IN ADDITION, THE RESIN AND ISOCYANATE HOSE FITTINGS HAVE DIFFERENT THREAD SIZES TO VIRTUALLY ELIMINATE INTERCHANGING THE HOSES.

THE HOSE CONNECTION POINTS ARE A POTENTIAL SOURCE OF CHEMICAL AND AIR LEAKS AND ARE THE AREAS MOST EXPOSED TO DAMAGE FROM SCUFFING AND SNAGGING ON ABRASIVE SURFACES. GUSMER CORPORATION STRONGLY RECOMMENDS INSTALLING THE OPTIONAL SCUFF JACKET TO PROTECT THE HOSES AND TSU EXTENSION HARNESS FROM DAMAGE.

1. Connect the isolation hoses to their respective primary heater outlet fittings (see Figure 10).

IMPORTANT: The heated hose assemblies are connected end to end during shipment to protect them from moisture intrusion. Do not separate the hoses until they are ready to connect to the proportioning unit.

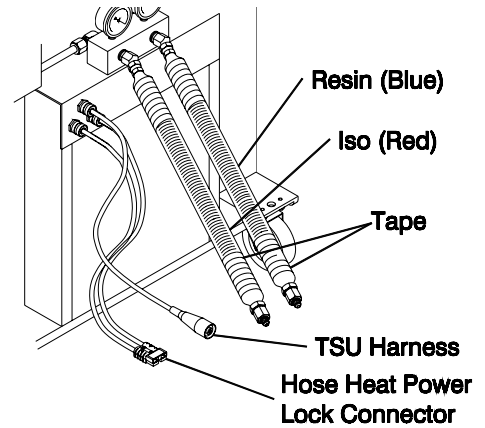

Figure 10. Isolation Hose Connections

2. Connect the heated hose assembly to the isolation hoses as follows:

- a) Lay out the hose assemblies end-to-end as shown (see Figure 11).

A- (isocyanate) hoses are color-coded RED.

R- (resin) hoses are color-coded BLUE.

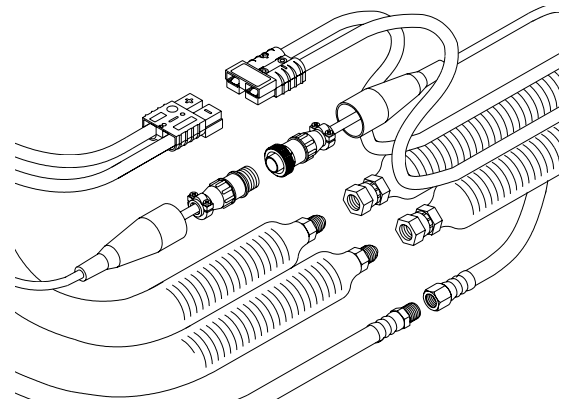

Figure 11. Hose Connection Step (a)

See Figure 12 for Steps b) and c).

- b) Connect the heated hoses to the isolation hoses. Take care not to cross-thread or over-tighten the fittings, ensuring a leak-proof chemical connection.
- c) Connect the air hoses and tighten the fittings with open-end wrenches.

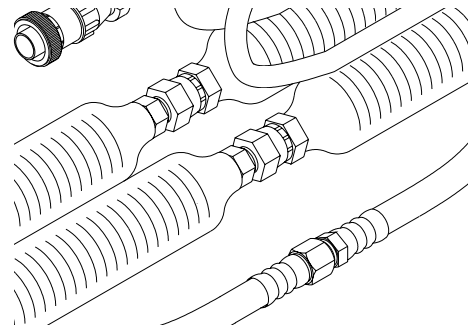

Figure 12. Hose Connection Step (b & c)

- d) Install the isolator between the chemical hose fittings and tape securely in place (See Figure 13).

IMPORTANT: Always install the isolator to prevent damage to the fittings.

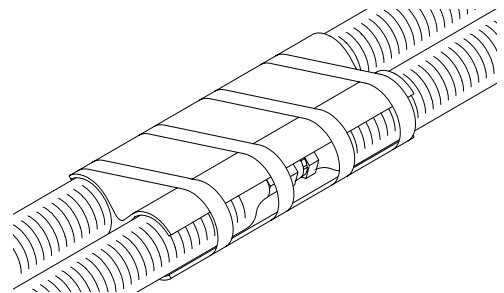

Figure 13. Hose Connection Step (d)

See Figure 14 for Steps e) and f).

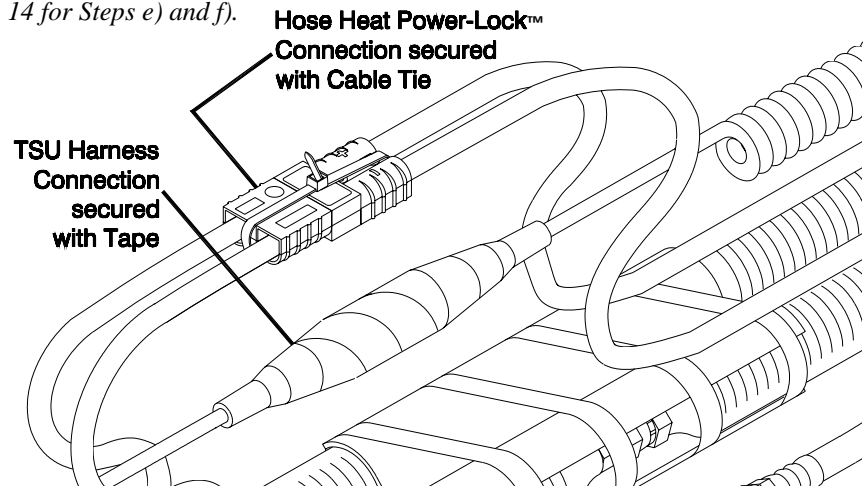

Figure 14. Hose Connection Step (e & f)

- e) Connect the TSU harness plugs together. To ensure a secure electrical connection, place the protective electrical isolator boot over each plug and tape together.
- f) Plug the Power-Lock™ hose heat connectors together. Secure the connection in place with the cable tie provided; failure to do so could cause a disruption in the hose heat system, should the connectors separate.

***** Repeat Step 2 for adding additional Hose Assemblies. *****

3. Install the temperature sensing unit (TSU) to the gun whip as follows: (see Figure 15)
 - a) Pull out and carefully straighten the loose end of the temperature probe from the TSU.
 - b) Insert the temperature probe into the isocyanate hose and connect the TSU to the hose whip, taking care not to cross thread or over-tighten the fittings, thereby ensuring a leak proof chemical connection.
 - c) Connect the ground wire on the gun hose to the ground point on the TSU.
 - d) Connect the heated hose assemblies to the TSU, taking care not to cross thread or over-tighten the fittings, thereby ensuring a leak proof chemical connection.
 - e) Connect the TSU harness to the TSU. To ensure a secure electrical connection, place the protective electrical isolator boot over each plug and tape together.
 - f) Connect and tighten the air hoses.
 - g) Cut the isolator in half and secure the two pieces in place between the hydraulic fittings.
 - h) Plug the Power-Lock hose heat connectors together. Secure the connection in place with the cable tie provided; failure to do so could cause a disruption in the hose heat system should the connectors separate.

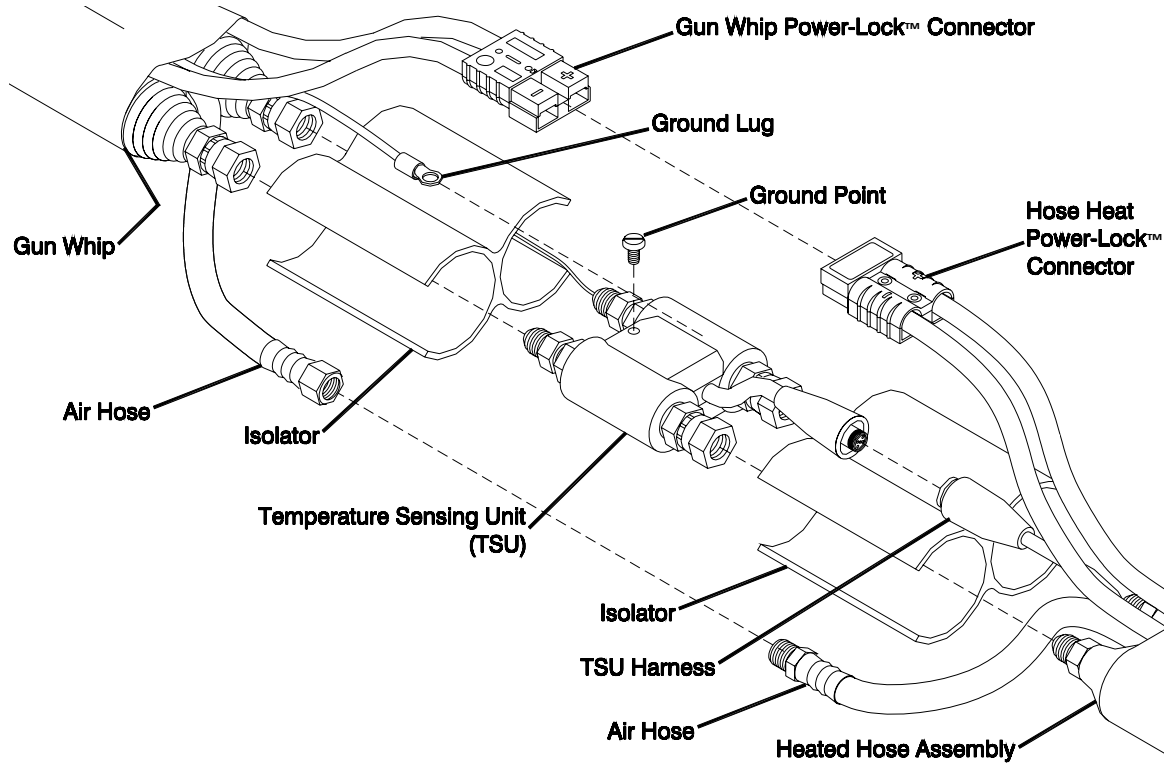

Figure 15. Temperature Sensing Unit (TSU) Connection



WARNING: THE TEMPERATURE SENSOR EXTENDS APPROXIMATELY 8 INCHES INTO THE ISOCYANATE HOSE AND ALTHOUGH IT IS A RUGGEDLY BUILT ASSEMBLY, IT WILL NOT WITHSTAND REPEATED ABUSE. CARE MUST BE TAKEN NOT TO CRUSH THE HOSE OR SUBJECT IT TO SEVERE BENDING IN THE AREA WHERE THE SENSOR IS LOCATED. TAKE CARE NOT TO COIL THE HOSE TIGHTER THAN THE RECOMMENDED 3 FT. MINIMUM BEND RADIUS.

4. Connect the main air source to the end of the air hose included with the heated hose assemblies.
5. Connect the coupling block to the gun hose and determine that the manual valves are closed. (See the Spray Gun Operating Manual.)

Air Purge

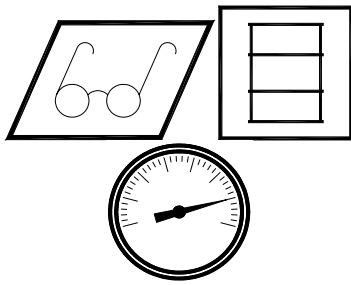

Before using the equipment, it is necessary to purge the entire chemical system of air and mineral oil left over from the functional testing of the equipment at the factory.

To purge the machine, proceed as follows:

1. Turn on the main air supply to the transfer pumps and drums/day tanks.
 2. Open both A- and R-inlet supply valves. Check for chemical leaks.
 3. Turn the hydraulic pressure control full counterclockwise. (See item 15 on page 10.)
 4. Turn ON the red main disconnect. The white main power light will light up.
 5. Turn ON the amber control power switch. The light within the switch and the temperature controllers will light up.
 6. Hold the coupling block with the A- and R- ports over separate containers and open both manual valves.
 7. Turn ON the hydraulic motor switch.
 8. Turn the pump switch to the NORMAL position. If necessary, gradually increase hydraulic pressure by turning the hydraulic pressure control clockwise to start the proportioning pumps moving slowly.
 9. Allow material to flow out of the coupling block until all spitting of air stops and all traces of residual material have disappeared. Close the manual valves and flush any residual chemical from the outside of the coupling block (see Spray Gun Operating Manual).
- IMPORTANT:** Properly dispose of waste chemicals in accordance with all applicable local, state, and federal codes.
10. Slowly increase the hydraulic pressure and check all fittings for signs of hydraulic and chemical leakage. Tighten fittings as required.
 11. Turn OFF the pump switch.
 12. Mount the spray gun to the coupling block.

IMPORTANT: After the proportioning system has been brought up to operating pressure and all hose connections are tight and free of leaks, wrap together the hoses and electrical wires around the area of the rubber isolators with a liberal amount of duct tape to form a compact bundle. If a scuff jacket is being used, pull it over the bundle and secure with tape.

AmpLok[®] Power Control System

The Amplok[®] Power Control System automatically maintains optimum power settings for the hose heat system for any hose length up to a maximum of 410 feet. There are no operator controls or adjustments required. The system eliminates the need for transformer tap settings, an ammeter, and a hose heat power set.

Digital Temperature Controllers

The H-20/35 Pro has three separate temperature controllers that automatically manage the temperature for the primary heaters and the hose heater. To change or enter the set point, proceed as follows:



WARNING: DO NOT TURN THE TEMPERATURE CONTROLLER ON UNTIL ALL PURGING PROCEDURES ARE COMPLETED AND THE HEATERS COMPLETELY FILLED WITH CHEMICAL. ADDITIONALLY, DO NOT CHANGE ANY OF THE PREPROGRAMMED PARAMETERS.

1. Check that the red main disconnect is ON. The white pilot light should be lit.
2. Check that the amber control power switch is ON. The light within the switch should be lit.

WATLOW CONTROLLER

NOTE:
The temperature controller normally displays the set point. When illuminated, the red LED number 1 on the temperature controller indicates that the heater is in heating mode. The LED goes out when the liquid in the heater reaches the set temperature. The LED will continue to cycle on and off, indicating that the controller is maintaining the set point temperature.

To enter or change the set point, press and hold the “Set” button down while pressing the \approx or \approx button to increase or decrease the value. After reaching the set point, release the “Set” button. The set point will automatically display after 10 seconds. (See Figure 16.)

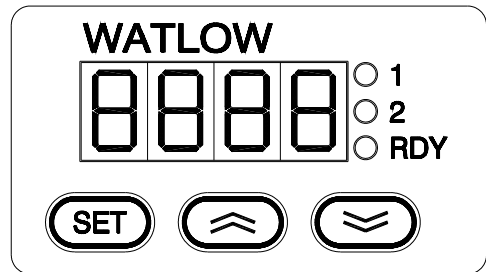

Figure 16. Watlow Temperature Controller

OGDEN CONTROLLER

NOTE:
The temperature controller normally displays the actual (process) temperature. When illuminated, the red LED on the temperature controller indicates that the heater is in heating mode. The LED goes out when the liquid in the heater reaches the set point temperature. The LED will continue to cycle on and off, indicating that the controller is maintaining the set point temperature.

To change the set point, tap the \approx or \approx button quickly. This will brightly illuminate the individual digit in the display to be changed. Once the desired digit is illuminated, press and hold the \approx or \approx button to increase or decrease the value. After the set point is entered, the process temperature will automatically display after 7 seconds. (See Figure 17.)

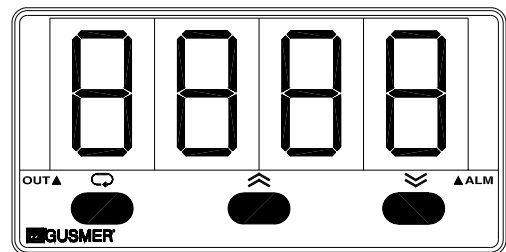

Figure 17. Ogden Temperature Controller

Press any one of the arrow keys again to view the set point. The process temperature will be displayed after 7 seconds.



WARNING: THE CONTROLLERS ARE FACTORY PROGRAMMED AND ARE NOT FIELD PROGRAMMABLE. IF YOU ENCOUNTER ANY PROBLEMS WITH EITHER CONTROLLER, CONTACT GUSMER FOR A REPLACEMENT. DO NOT SUBSTITUTE A CONTROLLER FROM AN ALTERNATE SUPPLIER AS ITS USE MAY RESULT IN DAMAGE TO THE EQUIPMENT AND/OR BODILY INJURY.



OPERATION

Daily Start-up Procedure

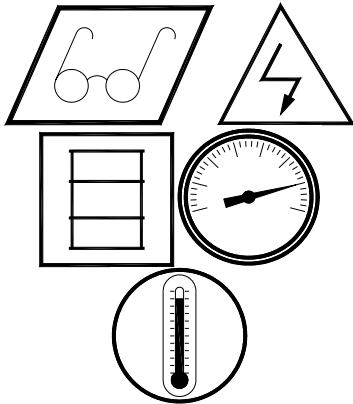

IMPORTANT: The Daily Start-up Procedures describe normal operation, assume that all calibrations have been properly executed, and that the heating system is not up to operating temperature.

1. Check the condition of the hydraulic and isocyanate lubrication systems and service as required. Change the pump lubricant when it shows signs of color change.
2. Determine that the supply system is at the proper temperature as recommended by the chemical system supplier, the individual chemicals are properly mixed within their drums/day tanks, and the moisture protection system is properly set for operation.
3. Check the inlet screens and service as required.
4. Turn on the main air supply to the transfer pumps and drums/day tanks.
5. Open both A- and R-inlet supply valves.
6. If the red emergency stop switch has been activated, reset it by turning the knob clockwise.
7. Turn ON the red main disconnect. The white main power light will light up.
8. Turn ON the amber control power switch. The light within the switch and the temperature controllers will light up.



WARNING: UNCOIL THE HEATED HOSES BEFORE TURNING ON THE HOSE HEATER SWITCH TO PREVENT OVERHEATING THE HOSES AND CREATING HOT SPOTS WITHIN THEM.

9. Turn ON the green hose heater switch. The light within the switch will light up and the temperature controller should begin to cycle toward its set point. If the set point needs to be changed, see Digital Temperature Controllers on page 22.
10. Turn ON the green A- and R- heater switches. The lights within the switches will light up and the temperature controllers should begin to cycle toward their set points. If either set point needs changing, see Digital Temperature Controllers on page 22.

IMPORTANT: Primary heating is almost instantaneous. Do not turn on the primary heaters until required for operation. Turn off the primary heaters during shutdowns exceeding one half-hour.



WARNING: TO PREVENT EXCESSIVE PRESSURE BUILDUP IN THE HEATED HOSES, ALWAYS BRING THE HOSE UP TO THE SET POINT TEMPERATURE BEFORE TURNING ON THE HYDRAULIC SYSTEM.

11. Turn ON the green hydraulic motor switch. The light within the switch will light up.

12. Turn the pump switch to NORMAL. One of the amber directional indicator lights will light and the proportioning pumps should move a short distance and pressurize.
13. Adjust the hydraulic pressure as required. (See item 15 on page 10.)

NOTE:
The pump switch must be in the RETRACT or NORMAL position to adjust the hydraulic pressure.

14. Check the pressure of each proportioning pump.
After setting the pump switch to NORMAL, monitor both pressure gauges. The resin and isocyanate pressures should be approximately equal and the pressures must remain fixed. Set the pump switch to RETRACT and observe the pressures again; they must remain fixed. If the pressure bleeds off on either stroke, see TROUBLESHOOTING, Proportioning System on page 28 before continuing.
15. The proportioning unit is now ready for operation. Connect air to the spray gun. Consult the spray gun operating manual and test spray as per the directions.

Daily Shut-down Procedure

1. Set the pump switch to RETRACT.
2. Trigger the spray gun off target until the isocyanate proportioning pump stops in the retracted position and the pressure of both pumps bleeds off to a point where the spray pattern begins to diminish.

IMPORTANT: *DO NOT bleed the pressure to zero, as some pressure is required to keep the packings operating normally and prevent seepage during shutdown.*

3. Turn OFF the green hydraulic motor switch. The light within the switch will go out.
4. Turn OFF the green A- and R- heater switches. The lights within the switches will go out.
5. Turn OFF the green hose heater switch. The light within the switch will go out.
6. Turn OFF the amber control power switch. The light within the switch and the temperature controllers should go out.
7. Turn OFF the red main disconnect. The white main power light will go out.
8. Close both A- and R-inlet supply valves.
9. Coil and store the heated hose in a manner that prevents damage.
10. Shut down the chemical supply system as required.
11. Turn OFF the main air supply to the transfer pumps/day tanks.
12. Shut down and service the spray gun as required (see spray gun operating manual).



TROUBLESHOOTING

General Information

When properly maintained and operated, GUSMER equipment will provide long and faithful service. However, occasional problems will arise which must be resolved before operation can continue. The purpose of this section is to give an explanation of what problems may arise, how to detect them, and how to resolve them.

This manual is written to give the operator a general overview of the operation of the equipment. Therefore it is imperative that before any troubleshooting process begins, the operators have read and understood the applicable portions of this manual.

Training schools held on a regular basis further develop the necessary knowledge for proper operation, maintenance and troubleshooting of GUSMER equipment. These schools give concentrated training on the equipment and help to develop an operator into a competent Certified Gusmer Technician. Obtain information on these schools from our sales office.

GUSMER maintains a competent staff of Technical Representatives and authorized Distributors who can resolve almost any problem you may encounter with GUSMER equipment. Feel free to call on these people for assistance when you need it.



WARNING: *THE TROUBLESHOOTING SECTION OF THIS MANUAL ASSUMES THAT THE INDIVIDUAL PERFORMING THE WORK ON THE EQUIPMENT IS QUALIFIED TO DO SO. THIS INDIVIDUAL MUST HAVE A WORKING KNOWLEDGE OF BASIC ELECTRICITY, HYDRAULICS AND PNEUMATICS; MUST FOLLOW ALL GENERALLY ACCEPTED SAFETY PRECAUTIONS USED WHEN WORKING WITH HYDRAULICS, PNEUMATIC AND ELECTRO-MECHANICAL EQUIPMENT; MUST HAVE READ AND UNDERSTOOD THE APPLICABLE SECTIONS OF THIS MANUAL; AND MUST WEAR PERSONAL PROTECTION APPROPRIATE TO THE TASK BEING UNDERTAKEN.*



WARNING: *UNLESS OTHERWISE NOTED, ALL ELECTRICAL TROUBLESHOOTING DESCRIBED IN THIS MANUAL MUST BE DONE WITH THE INCOMING POWER SWITCHED OFF AND LOCKED OUT AT THE SOURCE. ANY ELECTRICAL TROUBLESHOOTING REQUIRED BEYOND THE SCOPE OF THIS MANUAL MUST BE DONE BY A QUALIFIED ELECTRICIAN.*

Primary Heaters

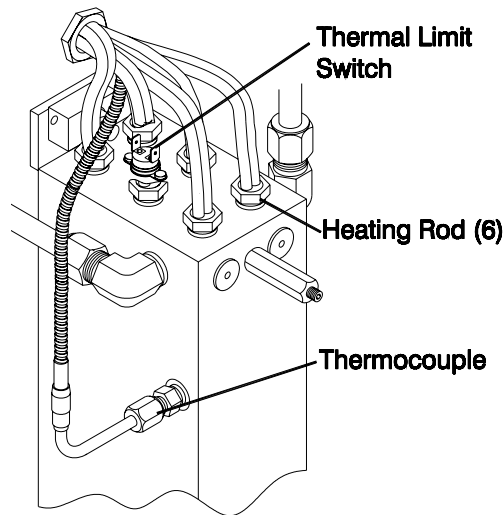
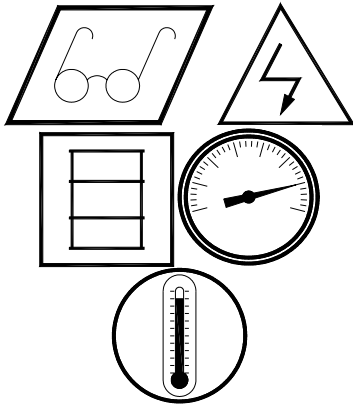

Figure 18. Primary Heater



Try the recommended solutions in the order given for each problem to avoid unnecessary repairs. Also, determine that all circuit breakers, switches, and controls are properly set and wiring is correct before assuming there is a problem. Allow primary heaters to cool and switch off the red main power disconnect before attempting troubleshooting procedures.

<u>Problems</u>	<u>Solutions</u>
Primary heater circuit breaker trips.	1
Primary heater does not heat; red LED light on the primary heater controller is ON.	2, 4, 3, 6
Primary heater does not heat; primary heater controller is ON.	4, 5
Primary heater controller displays error code.	4, 5
Primary heater heats but red LED on the primary heater controller is ON continuously.	3, 4, 6
Primary heater partially heats but red LED on the primary heater controller is ON continuously.	6, 7, 8
When flow starts the red LED on the primary heater controller comes on and stays ON for 30 seconds or more.	6

SOLUTIONS

1. **THERMAL LIMIT SAFETY SWITCH-** A completely independent over-temperature safety circuit has been provided, consisting of a thermal limit safety switch attached to each heater. When the surface temperature of the heater exceeds 230° F, the thermal limit safety switch will automatically interrupt the primary heater control contactor circuit, and trip that heater’s circuit breaker. Allow the temperature of the primary heater to cool down to within safe limits before resetting the primary heater circuit breaker. **DO NOT** attempt to reset the circuit breaker more than once. You must determine the cause of the problem and correct it.

2. **PRIMARY HEATER CIRCUIT BREAKER-**
With electric power disconnected and locked out at the source, open the console cover. Reset the primary heater circuit breaker if necessary. (See Figure 19.)

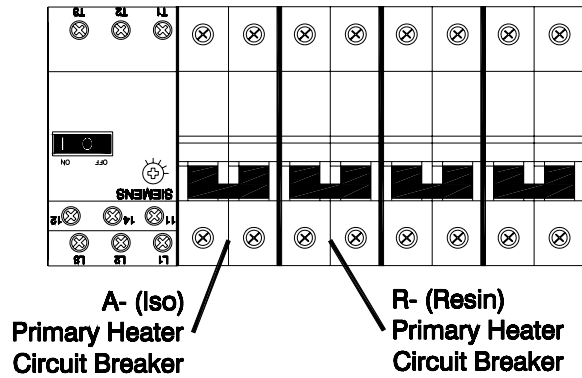

Figure 19. Primary Heater Circuit Breakers



WARNING: DO NOT ATTEMPT TO RESET THE CIRCUIT BREAKER MORE THAN ONCE. YOU MUST DETERMINE THE CAUSE OF THE PROBLEM AND CORRECT IT.

3. **PRIMARY HEATER SOLID STATE RELAY (SSR)-** Checking for normal SSR operation is not possible without electric power. Therefore, if all other testing fails to determine the source of problem, assume the SSR is inoperative and replace it.
4. **PRIMARY HEATER TEMPERATURE CONTROLLER-** The three temperature controllers on the H-20/35 Pro are directly interchangeable with one another. To determine if a controller is operating correctly, turn OFF the red main disconnect and replace the suspected controller with one known to be good.
5. **THERMOCOUPLE-** The temperature controller has a fail-safe feature that prevents the heating system from operating in the event of a signal failure from the thermocouple. In this case, replace the thermocouple. Refer to the Maintenance section of this manual for the proper procedures.

The positioning of the thermocouple in the outlet of the heat exchanger is critical to the proper operation of the primary heater. Therefore, two conditions must be satisfied:

- 1) The thermocouple must make positive contact with the heating rod.
- 2) The heating rod must be functioning properly.

The lack of either of these conditions may cause erratic temperature control and possible overheating. The thermocouple is properly positioned and mechanically locked in place at the factory. However, during maintenance or changing of the thermocouple, the positioning may have changed. Refer to the Maintenance section of the manual for proper thermocouple positioning.

6. **HEATING RODS-** the heater contains six (6) 1000-Watt (1500-Watt optional) heating rods wired in parallel. To check operation of the rods, measure their combined resistance with an ohmmeter as follows:
 - a) **(1X230V, 3X230V, and 3X460V units)-**
With main power OFF, read the resistance across terminal #2 on the resin SSR and terminal T2 on the resin heater contactor.
 - (3X380V units)-**
With main power OFF, read the resistance across terminal #2 on the resin SSR and the blue neutral terminal block.

b) **(1X230V, 3X230V, and 3X460V units)-**

With main power OFF, read the resistance across terminal #2 on the isocyanate SSR and terminal T2 on the isocyanate heater contactor.

(3X380V units)-

With main power OFF, read the resistance across terminal #2 on the isocyanate SSR and the blue neutral terminal block.

Compare the readings taken with the correct resistance shown in the chart below. A higher resistance indicates that at least one of the heating rods is inoperative. If this is the case, disconnect the heating rods and measure the resistance of each rod. The reading of each rod should be the same as that shown in the chart below. If not, replace the faulty rod or rods.

6000 Watt Heater		9000 Watt Heater	
Combined Resistance	Resistance Per 1000W Heating Rod	Combined Resistance	Resistance Per 1500W Heating Rod
8 Ohms	48 Ohms	5.3 Ohms	32 Ohms

7. **LOW LINE VOLTAGE-** The primary heater rating is 6000 Watts (9000 Watts optional) at a voltage of 220 Volts. Low line voltage will reduce the power available and the primary heater will not perform to its full capability.
8. The H-20/35 Pro primary heater is designed to maximize the heat transfer from the power available. However, under certain conditions, the heater will not be able to maintain the required temperature and will require a reduction in flow or the use of an auxiliary hose heat system. Call Gusmer Sales for information.

Proportioning System

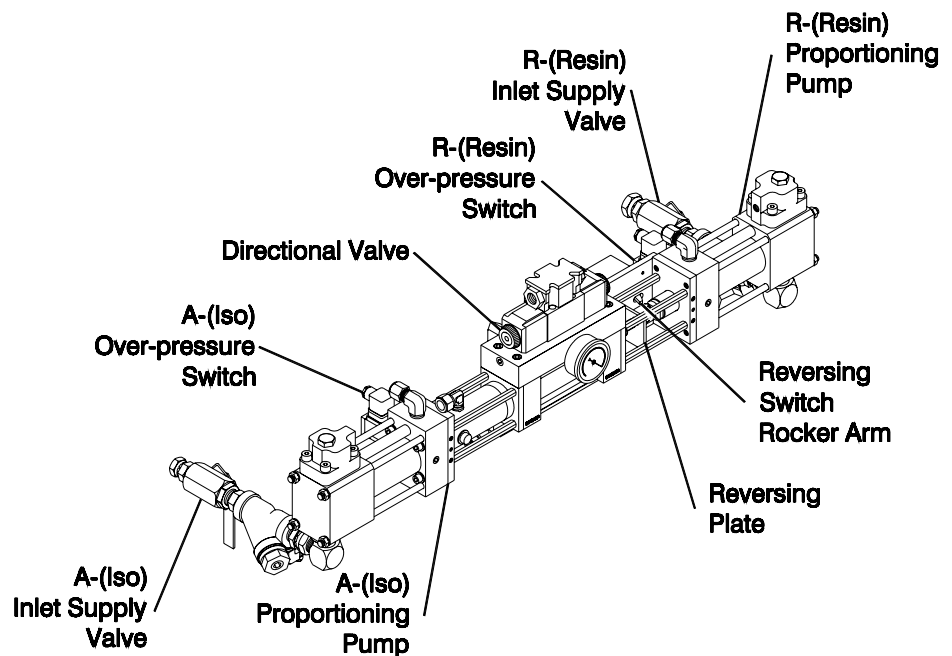
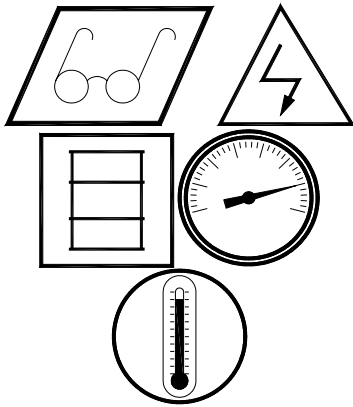

Figure 20. Proportioning System



Try the recommended solutions in the order given for each problem to avoid unnecessary repairs. Also, determine that all circuit breakers, switches, and controls and controls are properly set before assuming there is a problem. Allow chemicals to cool and switch off the red main power disconnect before attempting troubleshooting procedures.

<u>Problems</u>	<u>Solutions</u>
Proportioning pump does not hold pressure when stalled.	1
Pressure imbalance between pumps.	2, 3, 1
Cavitation in the proportioning pumps.	3, 2, 1
Failure of the pump to reverse.	4
Pumps do not move, and both directional indicator lights are out.	5, 4
Pump movement is erratic.	5

SOLUTIONS

1. LEAKING BALL CHECK VALVE -

- a) Determine which pump is losing pressure by observing the gauges.
- b) Determine in which direction the pump has stalled by observing which directional indicator light is ON.

Refer to the chart below to isolate the problem

<i>LEFT PUMP DIRECTIONAL INDICATOR LIGHT ILLUMINATED</i>	<i>RIGHT PUMP DIRECTIONAL INDICATOR LIGHT ILLUMINATED</i>
R-discharge ball check valve or components fouling.	R- pump inlet ball check valve or components fouling.
A-inlet ball check valve or components fouling	A-pump discharge ball check valve or components fouling

To service the ball check valve, proceed as follows:

- a) Switch off all electrical switches, breakers, and the main power supply.
- b) Close the appropriate inlet material supply valve and disconnect the air supply to the transfer pump.
- c) Bleed off chemical pressure to zero.
- d) Remove the appropriate ball guide. Inspect the ball seat gasket and replace as required. Flush and wipe clean the valve ball and ball seat of all residual material.

Using the ball seat removal tool, check the seat for proper seat compression. Snug the seat up to a ¼ turn maximum. The gasket should extend beyond the seat by approximately 1/16 of an inch. If this does not resolve the problem, remove the seat, inspect the gasket and replace as required.

In most cases, the cause of a leaking valve ball is a particle of foreign material preventing the ball from seating properly. If cleaning the valve ball and seat does not resolve the problem, replace these parts along with the gasket.

2. PRESSURE/CHEMICAL IMBALANCE -Troubleshooting this problem requires that two points be determined:

- a) Which chemical did not exit the mixing chamber?

- b) Why did the chemical fail to get there?

Determine the first point by checking the color of the material exiting the gun. Since two-component foam systems are usually a combination of light and dark material, the missing or under-proportioned material can be readily determined in most cases.

The second point is due to a restriction in the gun or because the proportioning pump did not function properly in pumping its designed volume.

After determining the missing or under-proportioned material, observe the chemical pressure gauges on the problem side of the proportioning unit to see if the malfunction is due to a restriction at the gun or a lack of material produced by the pump. To prevent misinterpretation, focus must be on the pressure gauge corresponding to the missing chemical.

For example: Assume that the R-component is not reaching the mixing chamber. Spray off target and note the resin pressure gauge; If the resin gauge is considerably higher than the isocyanate gauge, the problem is within the gun. Refer to the gun manual to resolve the problem. If the resin gauge is considerably lower than the isocyanate gauge, see step 3.

3. **CAVITATION**- Cavitation is the formation of a partial vacuum or void created within the pump cylinder during the fill stroke. It is actually a “short fill”, since the fill chamber is not completely full of chemical when the pump reverses to start the discharge stroke. Cavitation occurs when the proportioning pump demands a greater volume of material during its fill stroke than the supply system can deliver. The most common causes of cavitation are as follows:
- a) The transfer pump cannot handle the supply requirement or is malfunctioning. The Gusmer 2:1 transfer pump is recommended for use with the H-20/35 Pro. Also recommended is a minimum of 3/4” diameter supply hose, as short as practical.
 - b) The chemical is too viscous (thick) to pump properly. Consult your chemical supplier for the recommended material temperature required to maintain a viscosity of 250 to 1500 centipoise (cP).
 - c) Inlet strainer screen is restricted. Service as required. (See MAINTENANCE, Inlet Strainer Screen on page 39.)
 - d) An inlet valve ball and/or seat gasket that does not properly seat will permit some of the proportioned material to flow back towards the supply drum. When this happens, the proportioning pump will not pump the proper volume of material during the discharge stroke and an off-ratio condition will result. This malfunction will appear almost identical to cavitation, but somewhat less severe.
4. **REVERSING MALFUNCTION**- For the proportioning pumps to reverse direction, the activator plate must contact the rocker arm to activate the reversing switch. Failure of the activator plate to make proper contact is usually caused by something physical, such as a bent or loose activator plate or reversing switch.
- Should the above not be the cause, the failure of the activator plate to make proper contact is likely a result of a loose piston packing retaining bolt. This would cause the piston to contact the inner face of the pump inlet flange before the activator plate contacts the rocker arm. To resolve this, shut down the unit and disassemble the appropriate pump for repair.
- If the activator plate contacts the rocker arm but the directional valve fails to shift, the activator plate will pass the rocker arm and stop. When this happens, the first thing to do is to relocate the activator plate so that it is in the center of the rocker arm as follows:

- a) Restore electrical power and turn the pump switch OFF.
- b) Determine in which direction the plate must move: this depends upon which stroke is overrun.
- c) Go to the hydraulic manifold and locate the manual operator coil, on the same side of the machine toward which the activator plate must travel. For example: if the plate overran to the left, and requires moving it to the right, toward the resin pump, the manual operator on the resin side of the directional valve is the one to activate (See Figure 21).

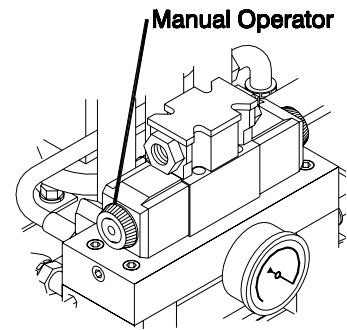

Figure 21. Hydraulic Manifold

Turn ON the main disconnect and motor control switches. Turn OFF the pump switch and bleed the chemical pressure to zero. With the coupling block manual valves open and pointed into a suitable waste container, push in the manual operator (a 3/16 Allen wrench is ideal for this) and hold it in until the activator plate is approximately centered. Release it when properly positioned and close the gun or coupling block.

If the spool seemed to move freely when pushed, the cause of the overrun was probably an electrical problem. Turn off the motor and place the pump switch in the NORMAL position. Push in each end of the rocker arm, listen for the shifting of the spool, and note the directional indicators light up appropriately. If the spool does not shift, or if the lights do not light, there is an electrical problem with the reversing switch, directional valve coil, or pump switch.

Should the spool hang up or be hard to push, it is likely that there is a mechanical problem within the directional valve, which will require shutting down the unit and disassembling the directional valve for service.

5. OVER-PRESSURE PROTECTION- Each proportioning pump contains a pressure switch set to 2200 psi, 2700 psi, or 3700 psi, depending upon the pump pressure rating. Upon reaching this pressure, the switch will automatically remove power from the directional valve, causing the pumps to stall. When the power is removed, both directional indicator lights will go off, which is the indication to the operator of an over-pressure condition. As this is a non-lockout type of system, the proportioning pumps will resume normal operation when the pressure bleeds off below approximately 2200 psi / 2700 psi / 3700 psi. However, the cause of the over-pressure condition should be determined and corrected. The three most likely causes are:
 - a) A restriction in the gun on the problem pump side.
 - b) Cavitation of the opposite pump
 - c) Hydraulic pressure set too high

Hydraulic Drive System

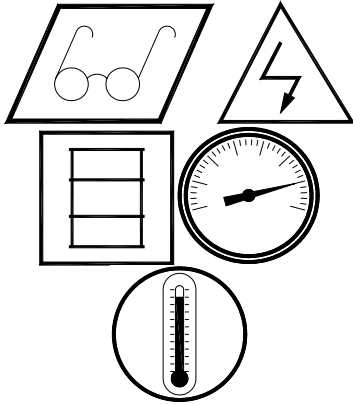

Try the recommended solutions in the order given for each problem to avoid unnecessary repairs. Also, determine that all circuit breakers, switches, and controls are properly set before assuming there is a problem. Allow hydraulic fluid to cool and switch off the red main power disconnect before attempting troubleshooting procedures.

<u>Problems</u>	<u>Solution</u>
Electric motor will not start or stops during operation.	1
Hydraulic pump does not develop pressure.	2
Low or zero pressure with screeching noises.	2, 3

SOLUTIONS

- MOTOR CIRCUIT PROTECTOR-** The motor circuit protector is set to trip when the electric motor draws too much current. To restore the motor to operation, switch OFF and lock out incoming power at the source, and allow the motor to cool. Reset the motor circuit protector to ON. (See Figure 22.)

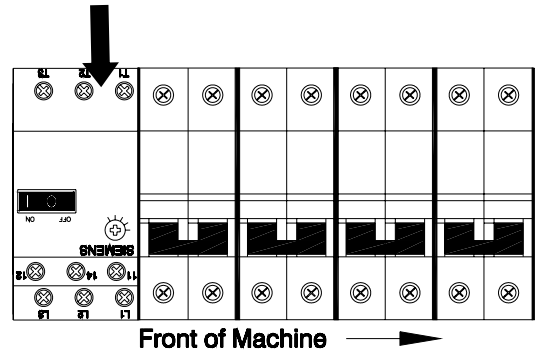

Figure 22. Motor Circuit Protector



WARNING: ALWAYS DETERMINE AND CORRECT THE CAUSE OF A TRIPPED MOTOR CIRCUIT PROTECTOR.

- ZERO OR LOW PRESSURE-** Note that hydraulic pressure cannot be generated when the hydraulic motor switch or pump switch is in the OFF position.

Assuming the pump is in proper working order, and the pump switch is set to NORMAL, the major cause of the pump's failure to produce pressure is that it is either not primed or loses its prime. To ensure a positive prime, check the following:

 - Check electric motor rotation. (See step 4 on page 16.)
 - Hydraulic reservoir filled to the proper level.
 - Pump case is full with hydraulic fluid.
 - Inlet fitting is fully tight to ensure no air is leaking into the pump case.
- SCREECHING-**the screeching noise is a characteristic of cavitation and is normal at initial start-up for a maximum of 30 seconds. If the screeching continues for more than 30 seconds, switch off the pump switch and hydraulic motor switch and check that the inlet fittings are tight and that the pump has not lost its prime.

A second cause of screeching can be excessive hydraulic oil temperature. Determine that the reservoir is properly serviced and if necessary provide better ventilation to permit the reservoir to dissipate heat more efficiently.

Hose Heat System

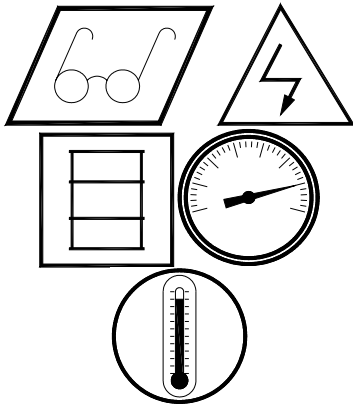

Try the recommended solutions in the order given for each problem to avoid unnecessary repairs. Also, determine that all circuit breakers, switches, and controls are properly set before assuming there is a problem. Allow chemicals to cool and switch off the red main power disconnect before attempting troubleshooting procedures.

<u>Problems</u>	<u>Solutions</u>
Hose warms but does not reach temperature or takes too long to reach temperature.	1, 7
Hose does not heat.	2, 3, 4, 5, 8
Hose heat controller displays error code.	3, 5
Hose heat circuit breaker trips.	2
Hose temperature not maintained during flow.	6, 7
Hose or hoses adjacent to the unit are warm, hoses downstream are cold.	8

SOLUTIONS

- HOSE LENGTH-** The hose heat system of the H-20/35 Pro is designed to maintain the chemical temperature developed by the primary heaters with up to 410 feet of hose. (Hose lengths greater than this require the use of an auxiliary hose heat system. Call Gusmer Sales for details.) In addition, if ambient temperature is too cold, the hose circuit may not have enough power to maintain the chemical temperature.

- HOSE HEAT CIRCUIT BREAKER-** Switch OFF and lock out incoming power at the source. Open the console and locate the hose heat circuit breaker. Reset the breaker if necessary. (See Figure 23).

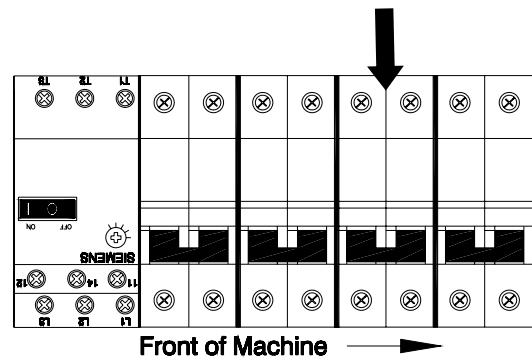

Figure 23. Hose Heat Circuit Breaker

- HOSE HEAT TEMPERATURE CONTROLLER-** The three temperature controllers on the H-20/35 Pro are directly interchangeable with one another. To determine if the control unit is operating correctly, switch OFF and lock out incoming power at the source and swap the suspect controller with one known to be good.

4. AMPLOK[®] HOSE HEAT CONTROLLER-

The AmpLok[®] Controller requires that three conditions be met for proper function:

- 220 Volts AC to power the controller
- 5 to 24 Volts DC to operate the control circuit
- A complete electrical circuit through the hose heater.

If these three conditions are met, two Red Status Lights will be illuminated. (See Figure 24.)

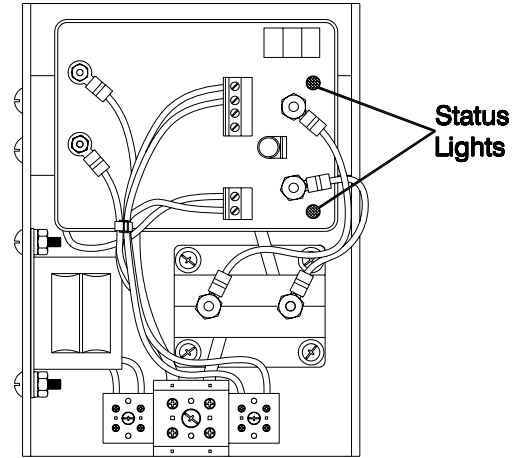

Figure 24. AmpLok[®] Hose Heat Controller

a) **Problem:** Both Status Lights are out.

Cause: Loss of AC or DC Power.

Solutions:

- 1) Connect a voltmeter across Terminals 1 and 2 on the controller. If 220 Volts AC is present proceed to Step 2). If voltage is not present turn off power to the machine. Open the console and locate the Hose Heat Circuit. Reset if required. Recheck to insure that power is present between Terminals 1 and 2.
- 2) Connect a voltmeter across Terminals 5 and 6 on the controller. If 5 to 24 Volts DC are present, replace the control unit.. The DC voltage is supplied to the controller by the Hose Heat Temperature Controller. If 5 to 24 Volts DC are not present, replace the Hose Heat Temperature Controller.

b) **Problem:** One Status Light is out.

Cause: Open Hose Heat Circuit or Defective AmpLok[®] Module.

Solutions:

- 1) Disconnect the hose heat by unplugging the Power Lock Connector at the Machine. Turn on the Hose Heat. Connect the voltmeter across the Terminals of the Power Lock Connector on the machine. If 120 Volts are present there is an open circuit in the hose heat circuit. If no voltage is present replace the AmpLok[®] Module.

5. TEMPERATURE SENSING UNIT (TSU)- Two conditions must be satisfied for proper operation:

- The sensor must be functional.
- The signal must travel uninterrupted from the sensor to the control unit.

Unplug the TSU from its extension. Without undoing any chemical connections, move the hose section with the TSU to the proportioning unit, plug the TSU directly into the TSU extension harness, restore electrical power and energize the hose heat circuit. If control is not restored, change the TSU. If control is restored, systematically check each section of the TSU wire harness out to the gun.

6. **PRIMARY HEAT AND HOSE HEAT SETTINGS-** The purpose of the hose heat system is not to add heat but rather to maintain the temperature developed by the primary heater. If it appears that the hose heat system is not maintaining temperature during flow, check that the primary heater and hose heat controllers are set for the proper temperatures or reduce the output.
7. **LOW LINE VOLTAGE-** The hose heat system operates at 220 Volts. Low line voltage will significantly reduce power available and the heater will not perform to its full capability at maximum hose length.
8. **HOSE HEATING ELEMENT-** With the hose heater switch OFF, check to see that the Power-Lock connectors on the hoses and all electrical connections between the hoses and proportioning unit are tight. If these connections are secure and hose heat is not present, then make a systematic search for the electrical fault as follows:
 - a) With the hose heater switch OFF, starting at the gun whip, unplug the Power-Lock connectors and plug the hose jumper plug into the last “upstream” segment of hose.
 - b) Turn ON the hose heater switch;
If hose heat is restored, then the fault is within the gun whip hose.
If hose heat is not restored, turn OFF the hose heater switch, control power switch, and the main power disconnect and proceed with the steps below:
 - c) Unplug the next set of Power-Lock connectors and plug the hose jumper plug into the last “upstream” segment of hose.
 - d) Restore electrical power, and switch ON the hose heat circuit;
If hose heat is restored, then the fault is within the last unplugged segment of hose.

If hose heat is not restored, turn OFF the hose heater switch, control power switch, and the main power disconnect and repeat steps c) and d) until the fault is located.



MAINTENANCE

To realize full productivity and maximum service life from the H-20/35 Pro, it is necessary to perform certain maintenance procedures daily or periodically.



WARNING: *THE MAINTENANCE SECTION OF THIS MANUAL ASSUMES THAT THE INDIVIDUAL PERFORMING THE WORK ON THE EQUIPMENT IS QUALIFIED TO DO SO. THIS INDIVIDUAL MUST HAVE A WORKING KNOWLEDGE OF BASIC ELECTRICITY, HYDRAULICS AND PNEUMATICS; MUST FOLLOW ALL GENERALLY ACCEPTED SAFETY PRECAUTIONS USED WHEN WORKING WITH HYDRAULICS, PNEUMATIC AND ELECTRO-MECHANICAL EQUIPMENT; MUST HAVE READ AND UNDERSTOOD THE APPLICABLE SECTIONS OF THIS MANUAL; AND MUST WEAR PERSONAL PROTECTION APPROPRIATE TO THE TASK BEING UNDERTAKEN.*



WARNING: *UNLESS OTHERWISE NOTED, ALL MAINTENANCE DESCRIBED IN THIS MANUAL MUST BE DONE WITH THE INCOMING POWER SWITCHED OFF AND LOCKED OUT AT THE SOURCE. ANY ELECTRICAL TROUBLESHOOTING REQUIRED BEYOND THE SCOPE OF THIS MANUAL MUST BE DONE BY A QUALIFIED ELECTRICIAN.*

Primary Heaters



WARNING: *THE CHEMICAL COMPONENTS ARE PRESSURIZED UP TO 3500PSI. BEFORE OPENING ANY HYDRAULIC CONNECTIONS OR SERVICING HYDRAULIC COMPONENTS, USE EXTREME CAUTION TO ENSURE THAT ALL PRESSURES HAVE BEEN BLED TO ZERO.*

HEATING RODS

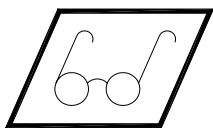

The sheath on the H-20/35 Pro heating rod is made from a special alloy designed to be resistant to corrosion and erosion. However, if the sheath should fail, fluid under pressure will leak into the heating rod. This may result in leakage through the potting at the junction end of the rod.

1. Turn OFF the main disconnect.
2. Remove the heater cover.
3. If removing the outer front heating rod, the thermocouple requires removal. Using an open-end wrench, loosen the compression nut that holds the thermocouple in place. Remove the thermocouple.
4. Disconnect the heating rod lead wires and, using an open-end wrench, loosen the heating rod and remove it. Since fluid surrounds each rod, be prepared to catch the residual fluid as the rod is withdrawn. Inspect the rod; it should be relatively smooth and shiny. If there is crusted, burnt ash-like material adhered to the rod or the sheath shows pitting marks; replace the heating rod(s).
5. Perform a heating rod resistance check (see TROUBLESHOOTING, Primary Heaters on page 26).
6. Apply thread sealant to the threads of the heating rod and install it using an open-end wrench.

7. Install the thermocouple and tighten the compression nut using an open-end wrench (see Thermocouple Replacement on page 37).
8. Reconnect the heating rod lead wires to the power leads, wiring them in parallel.
9. Replace the heater cover.

THERMOCOUPLE REPLACEMENT

The thermocouple includes the compression nut and ferrule (see Figure 25). Once locked in place, the ferrule becomes a permanent part of the thermocouple and cannot be relocated or removed. The location of the thermocouple is critical to the operation of the primary heater and requires proper positioning before tightening the compression nut.

1. Using an open-end wrench, securely tighten the compression fitting body into the heat exchanger tube to prevent any leakage.
2. Install the heating rod and heat exchanger spring into the tube, if they were removed.

3. With the compression nut and ferrule in place, insert the thermocouple into the body until it makes contact with the heating rod. Make sure that the spring does not obstruct the placement of the thermocouple against the rod.
4. Firmly hold the thermocouple in place against the rod and using an open-end wrench, tighten the compression nut.

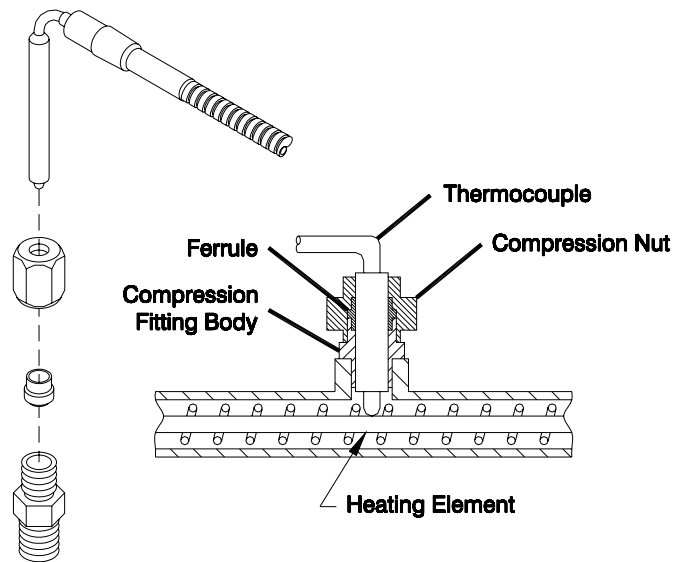
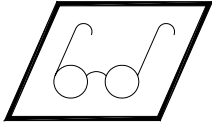

Figure 25. Thermocouple Components

Proportioning System

PROPORTIONING PUMPS



When the proportioning pumps are functioning properly, it is not unusual for a trace amount of resin chemical to seep past the pump packing onto the resin pump shaft. Routinely inspect the shaft and wipe away any residue when the proportioning unit is turned off. Disassemble and clean the proportioning pumps annually. Inspect the pistons and cylinder for mars or scratches, which may cause leakage or damage to packings. Gusmer also recommends replacing the piston and cylinder packings, expanders, and packing springs on an annual basis as a preventative maintenance precaution. (Refer to the *Proportioning Pump Assembly* section of the *Parts I.D.* for reference.)



WARNING: AFTER REASSEMBLING OR SERVICING THE PROPORTIONING PUMPS, TORQUE THE PUMP TIE RODS TO 30 FT/LBS.

PUMP BASES

Disassemble and clean both pump bases annually as follows:
(Refer to the *Pump Base Assembly* section of the *Parts I.D.* for reference.)

1. Perform the Daily Shut-down procedure and bleed all chemical pressures to zero.
2. Using the supply ball seat removal tool, (5/8 hex stock) unthread and remove the supply ball seat. Using the discharge ball seat removal tool, unthread and remove the discharge ball seat.
 - a) Clean the gasket seating surfaces on the underside of the each seat and inside the each pump base cavity.
 - b) Inspect the each seat gasket and replace as required.
 - c) Inspect each ball seat for nicks or scratches. Replace as required.
 - d) Thoroughly clean the thread on each seat before replacement. Coat the threads with a liberal amount of Lubriplate brand grease.
 - e) Install each seat with gasket by threading the seat into the base by hand until the gasket bottoms inside the pump base. Use a 6" adjustable wrench to snug the seat approximately ¼ turn.
 - f) **DO NOT OVER TIGHTEN.** It may be necessary to periodically retighten each seat throughout the life of the gasket.
3. Wipe each valve ball clean and inspect for nicks. Replace as required and complete the pump base reassembly.

Inlet Strainer Screen

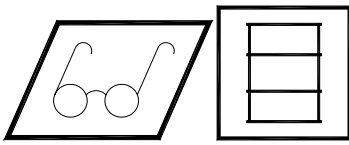

A strainer screen in each proportioning pump filters out solid matter that could adversely effect the operation of the ball check valves in the pump base. Both screens should be inspected daily and cleaned as required, as indicated in the Daily Start-up procedure.

The isocyanate component can crystallize from either moisture contamination or from freezing. If the chemicals received are clean and if proper storage, transfer, and operating procedures are followed, there should be minimal contamination of the isocyanate screen. In practice though, it is good preventative maintenance to clean the isocyanate screen daily.

IMPORTANT: Clean the isocyanate pump screen during the start-up procedure only. This will minimize moisture contamination problems by immediately flushing out any isocyanate residue at the start of the dispensing operation.

Remove and clean the strainer screen as follows:

1. Close the material supply valve at the inlet and disconnect the air supply of the appropriate proportioning pump. This prevents material from being pumped when the strainer screw is removed.
2. Place a container beneath the strainer base to catch the drain-off of chemical when removing the strainer screw.

NOTE:
More than 25% restriction of the strainer screen can prevent proper filling of the pump during operation.

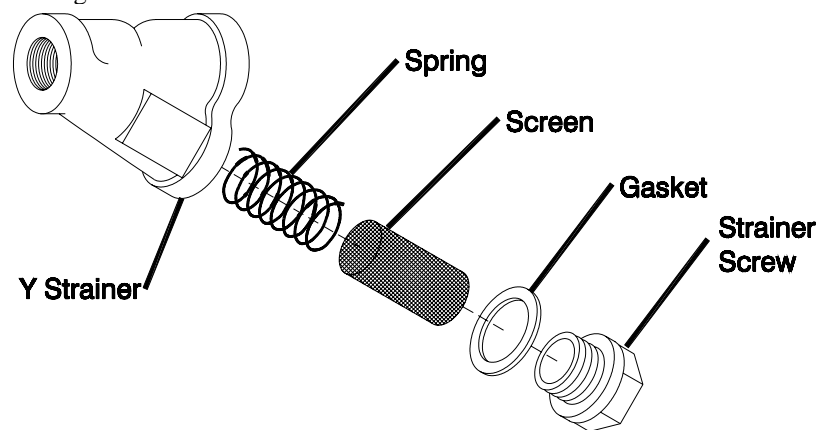
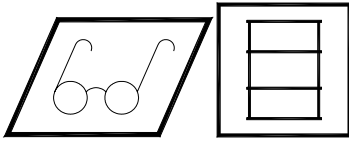

Figure 26. Y Strainer Components

3. Remove the screen from the strainer base. Thoroughly flush the screen with gun cleaner and shake it dry. Inspect the screen for blockage: *no more than 25% of the mesh should be restricted*. If more than 25% blocked, replace the screen. Inspect the strainer screw gasket and replace as required.
4. Install the strainer screw with the spring, screen and gasket in place and tighten. Take care not to over-tighten; let the gasket make the seal.
5. Open the material supply valve, ensure there are no leaks and wipe the equipment clean.
6. Proceed with operation.

Pump Lubrication System



To ensure that the pump lubricant will do its job, check its condition on a daily basis. Change the lubricant before it becomes a gel, or when its color darkens as it becomes diluted with isocyanate.

Gel formation is due to moisture absorption by the pump lubricant. The time interval between changes due to gel formation depends on environmental conditions in which the equipment is operating. The enclosed lubrication system of the H-20/35 Pro minimizes exposure to moisture, but moisture contamination is still possible.

Discoloration of the pump lubricant is due to continual seepage of small amounts of isocyanate past the pump packing during operation. However, if the packing within the isocyanate pump is functioning properly, lubricant replacement due to discoloration should not be more frequent than 3 or 4-week intervals.

To change the pump lubricant, proceed as follows:

1. With the coupling block manual valves open and pointed into an appropriate waste container, stop the isocyanate proportioning pump in the extreme right position by jogging the pump switch. Close the gun (or manual valves) and turn off the hydraulic motor switch and pump switch.
2. Lift the lubricant reservoir out of the bracket and remove the cap from the container. Holding the cap over a suitable container, remove the check valve and allow the lubricant to drain. Reattach the check valve to the inlet hose.
3. Drain the reservoir and flush it with clean lubricant.
4. With the reservoir flushed clean, fill with fresh lubricant.
5. Thread the reservoir onto the cap assembly and place it into the bracket. (See Figure 9 on page 17.)
6. Push the larger diameter supply tube approximately 1/3 of the way down into the reservoir.
7. Push the return tube down into the lube reservoir until it reaches the bottom.

The lubrication system is now ready for operation. No priming is required.

Hydraulic Drive System

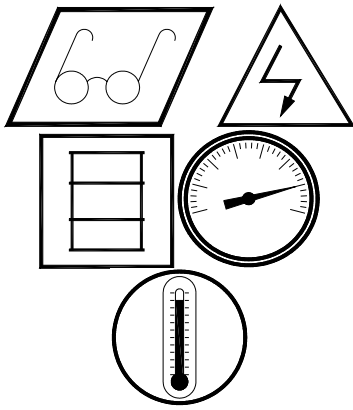

The hydraulic drive system should be checked annually for cleanliness and the fluid changed in accordance with the manufacturer's recommendation.

To service the hydraulic drive system, proceed as follows:

1. Perform the Daily Shut-down Procedures and allow the hydraulic fluid to cool.
2. Thoroughly clean the tank top, the access cover plate, and the components in the area of the cover plate. This will ensure that no foreign matter will enter the hydraulic reservoir when removing the cover plate.
3. Remove the six (6) cover plate mounting screws. Separate the hydraulic suction pipe from the fitting connecting the pipe to the hydraulic pump.
4. Remove the cover and pipe from the hydraulic reservoir.
5. Inspect the bottom of the reservoir for sediment. If sediment is present, drain the hydraulic fluid, thoroughly clean the tank, and refill with new fluid.
6. Replace the cover and the suction pipe; connect and tighten the suction pipe to the fitting on the hydraulic pump; and secure the cover in place with the mounting screws.
7. Check to ensure the hydraulic pump is full with hydraulic fluid.
8. Proceed with normal operation.

IMPORTANT: Upon starting the motor, the hydraulic pump may make a screeching noise for a short time upon initial start-up. Should this noise continue for more than 30 seconds, switch off the motor control and refer to **TROUBLESHOOTING, Hydraulic Drive System** on page 32.



APPENDIX

Formula for calculating proportioning unit output:

$$Q \text{ (lbs/min)} = S \text{ (strokes/min} \times .31)$$

Recommended hydraulic fluids:

- Mobil DTE 24
- Mobil DTE 25
- Cooks Albavis 10

Alternate hydraulic fluids:

- American Oil & Supply-PQ Iso VG 32
- Gulf Oil-Harmony 32AW (43AW)
- Ashland-Valvoline AW 15
- Atlantic Richfield-Duro AWS-150
- BP Oil-Energol HLP-C32
- Cities Service-A/W Hydraulic 15
- Cook's-Albavis 8
- Exxon-Nuto H-32(44)
- Fiske Bros.-Lubriplate Hydraulic #0
- E.F. Houghton-Hydro-Drive HP-150
- A. Margolis-T.I.P.100-15-7
- Shell-Tellus 32(25)
- Stewart Warner-Alemite Hydraulic HD#0
- Sun Oil-Sunvis 706
- Texaco-Rando HD32 (HD A)
- Chevron IS032
- White & Bagley - EP Hydraulic 150

Number	Field Title	Description
1	Date	Enter date report is submitted.
2	Name	Enter name of person making report.
3	IM Number	Enter the Part Number of the Instruction Manual from the title page.
4	Issue Number	Enter the Issue number of the Instruction Manual from the title page. If there is no issue number, enter NONE .
5	Date of Issue	Enter the date of Issue of the Instruction Manual from the title page. If there is no issue date, enter NONE .
6	Page Number	Enter the page number containing the discrepancy.
7	Discrepancy	Provide a brief description of discrepancy.

NOTE: You may send a marked copy of the page as an attachment to your submittal.