



---

**DRUM MIXER  
OPERATIONS MANUAL  
604001 & 610072**



---

**IPM, INC.**

**Manufactured by: International Pump Manufacturing, Inc.**

# AIR DRUM MIXER

## OPERATIONS MANUAL and PARTS IDENTIFICATION DRAWINGS

This manual contains IMPORTANT WARNINGS and INSTRUCTIONS. Read and retain for reference.

International Pump Mfg, INC.  
3107, 142nd Avenue E Suite 106,  
Sumner, WA 98390

U.S.A.

TEL: (253) 863 2222

FAX: (253) 863 2223

Website : [www.ipmpumps.com](http://www.ipmpumps.com)

**For Technical Service Call Your Local Distributor**

Copyright 2008 by: International Pump Mfg, Inc.

Revised: 1 January 2011

---

---

**WARNING:** The equipment described herein must only be operated or serviced by properly trained individuals, thoroughly familiar with the operating instructions and limitations of the equipment.

---

Notice: All statements, information and data given herein are believed to be accurate and reliable but are presented without guarantee, warranty or responsibility of any kind expressed or implied. Statements or suggestions concerning possible use of IPM equipment are made without representation or warranty that any such use is free of patent infringement, and are not recommendations to infringe any patent. The user should not assume that all safety measures are indicated or that other measures may not be required.

# TABLE OF CONTENTS

1.0	SAFETY WARNINGS	4
2.0	INSTALLATION	5
3.0	OPERATIIONS	6
	3.1 Mixer operating tips	6
	3.2 Fluid mixing tips	7
4.0	PARTS IDENTIFICATION	8
5.0	TECHNICAL SPECIFICATIONS	10
	5.1 Performance graph	10
	5.2 Operating parameters	11
6.0	WARRANTY & DISCLAIMER	13

## **1.0 SAFETY WARNINGS**

Please read and observe all warnings contained in this operations manual before making any attempt to operate the equipment.

### **Misuse of equipment**

Use the equipment only for its intended purpose. Care should be taken to prevent over pressurization of the pump or accessories connected to it. Use and repair only with proper parts. Improper use or misuse of this equipment could result in fluid being splashed or sprayed on the skin or in the eyes, serious bodily injury, property damage, fire or explosion.

Make daily maintenance check on the equipment and repair damaged or worn parts immediately. Do not alter this equipment in any way as doing so could cause drum mixer malfunction and/or serious bodily injury.

### **Material & fluid compatibility**

Always ensure the chemical compatibility of the fluids and solvents with the wetted parts when using IPM equipment. Check the fluid manufacturer's data sheets and specifications before using chemicals or solvents with IPM equipment.

### **Pressurized hoses**

Because the air and fluid hoses are pressurized they present a potential danger should the air or fluid escape at high pressure. This escaping fluid can spray out and cause serious bodily injury or property damage. Inspect frequently and ensure that the hoses do not leak or rupture due to wear, misuse or damage.

The drum mixer and hoses should be handled properly; do not use the drum mixer or hoses as leverage to move the equipment. Use the hoses only for fluids in which they are compatible with for both the inner liner and the outer covering. Use care not to exceed the temperature rating of the hose.

Before each use, ensure that the fluid and air couplings are tight and not damaged. Check the drum mixer and components for leaks, bulging hose cover, damaged fittings and loose bolts. Always ensure drum mixer is secure in bung before operation.

### **Pressure specification**

The maximum working air pressure of this equipment is *100 psi (7 bars)*. Ensure all equipment and accessories used with this drum mixer are rated to withstand this maximum working pressure. Never exceed the maximum working pressure of the mixer or any device attached to it.

## 2.0 INSTALLATION

### 2.1 Typical air motor set-up

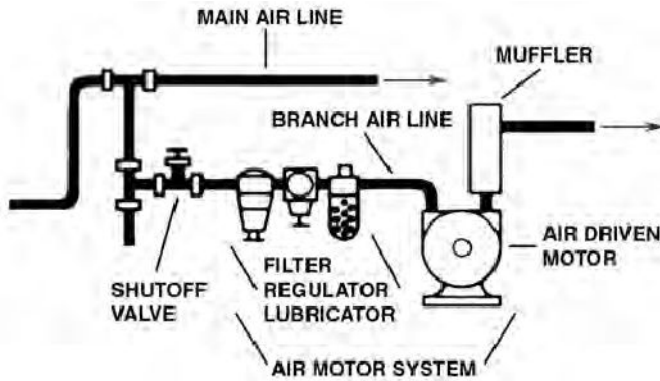

This set-up represents only one of many possible configurations. Other set-ups are possible depending on your specific application.

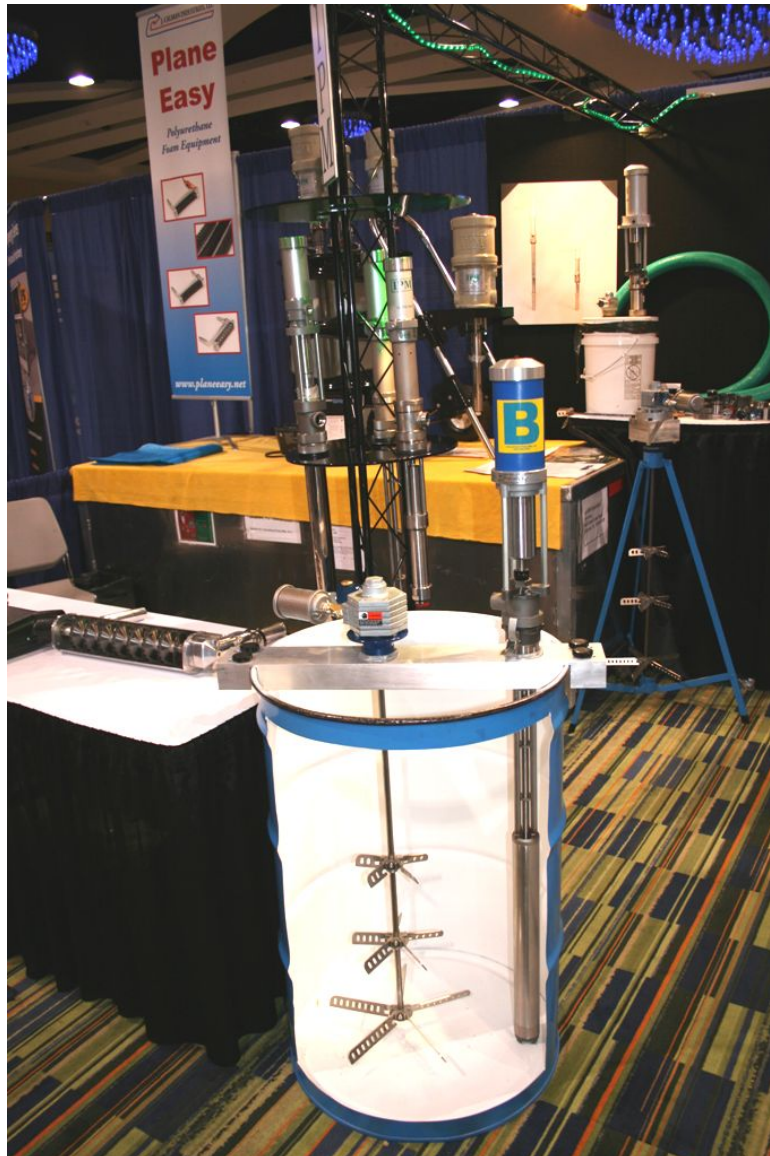

## 3.0 OPERATIONS

### 3.1 Drum mixer operating tips

An 8" blade on the bottom of the mixer shaft is standard on each drum mixer to get maximum pull of heavy materials from the bottom of the barrel. Additionally, two 6" upper blades assist in pulling fluid from the sides of the drum for optimum mixing capability.

If you do not have a center bung in your drum, IPM has designed an off-set bung adaptor riser (IPM part #610067) that angles the mixer shaft away from the sides of the drum to allow proper chemical mixing. As a temporary measure, you can also take an 18" – 20" piece of 2" diameter threaded pipe and screw into your bung. Carefully bend/point the top of the pipe away from the center of the drum, tilting the bung for better mixer clearance.

The amount of air you will need to mix your fluids will depend on certain factors such as viscosity, mixing speed, specific chemical, temperature, etc. Typically, 10 - 20 CFM air pressure is sufficient for mixing operations. A 3/8" ball valve can be used effectively as a metering or speed control measure.

Proper blade rotation is important for the swing out style blade assemblies to function correctly. Looking from the bottom of the drum mixer, the shaft/blade rotation should be clockwise for proper swing-out of the blades.

Certain chemicals are the type that set up or seize the folding blades if allowed to solidify on the blade assemblies. **ENSURE YOU PERFORM THIS OPERATION IN AN AREA THAT IS WELL VENTILATED AND HAS NO FIRE HAZARDS.** If this should happen, an effective way to remove the hardened chemicals is to heat the blades with a welding or propane torch to burn the residue off. Since the blades are stainless steel, the heat will not adversely affect them. It is not necessary to heat the blades to a point they become red hot. Once the cleaned blade assemblies have cooled, clean the remaining debris from the assembly and lubricate with WD-40 or an equivalent lubricant, then test to ensure they swing freely for proper operation.

A few drops of oil in the air **inlet** port helps to lubricate the air motor. With proper maintenance, the air motor on this drum mixer will work efficiently for many years. If moisture is present in your air supply, muffler freezing can occur during longer mixing operations. If this happens, simply take the muffler apart and wash in warm water. Ensure the muffler is completely dry before re-installing it back on the air motor. Do not drop the air motor as the hex top cap is plastic.

The DM-101 drum mixer is a very effective tool in 55 gallon barrel mixing operations. Complete fluid mixing can be achieved in short periods of time, usually within 30 minutes. The unique folding action design of the blade allows the mixing shaft to pass through the 2" bung in most drums and with two 6" and one 8" blade, optimum mixing is achieved throughout the drum.

## 3.2 Fluid mixing tips



- Do not pull too deep a vortex as this will entrap air into the fluid.
- Do not pull too shallow a vortex as this will cause unbalanced mixing of fluids.
- Tilting the barrel slightly will help reduce air entrapment.
- For proper mixing, the actual blades should be 1/3 the diameter of the drum. Example; a 24" drum requires an 8" mixing blade.
- Mix fluids for only 30 - 45 minutes. Don't over-mix chemicals.
- Slower speeds entrap less air into fluids during mixing process.
- Never mix ISO fluid with drum mixer as this will entrap air into the chemical.
- "B" components in fast set coatings such as polyurea require mixing with drum mixer.
- Always lubricate drum mixer motor for maximum life expectancy.
- Collapsible blades make IPM drum mixer compatible with any barrel.
- Use IPM's new 13" mixing blade assembly for tote application.
- Use off-set bung adaptor riser to prevent mixing blades from contacting interior drum wall on drums with an off-center bung hole.

## 4.0 PARTS IDENTIFICATION

Parts illustration for air driven drum mixer (Drum length)  
Part # 604001

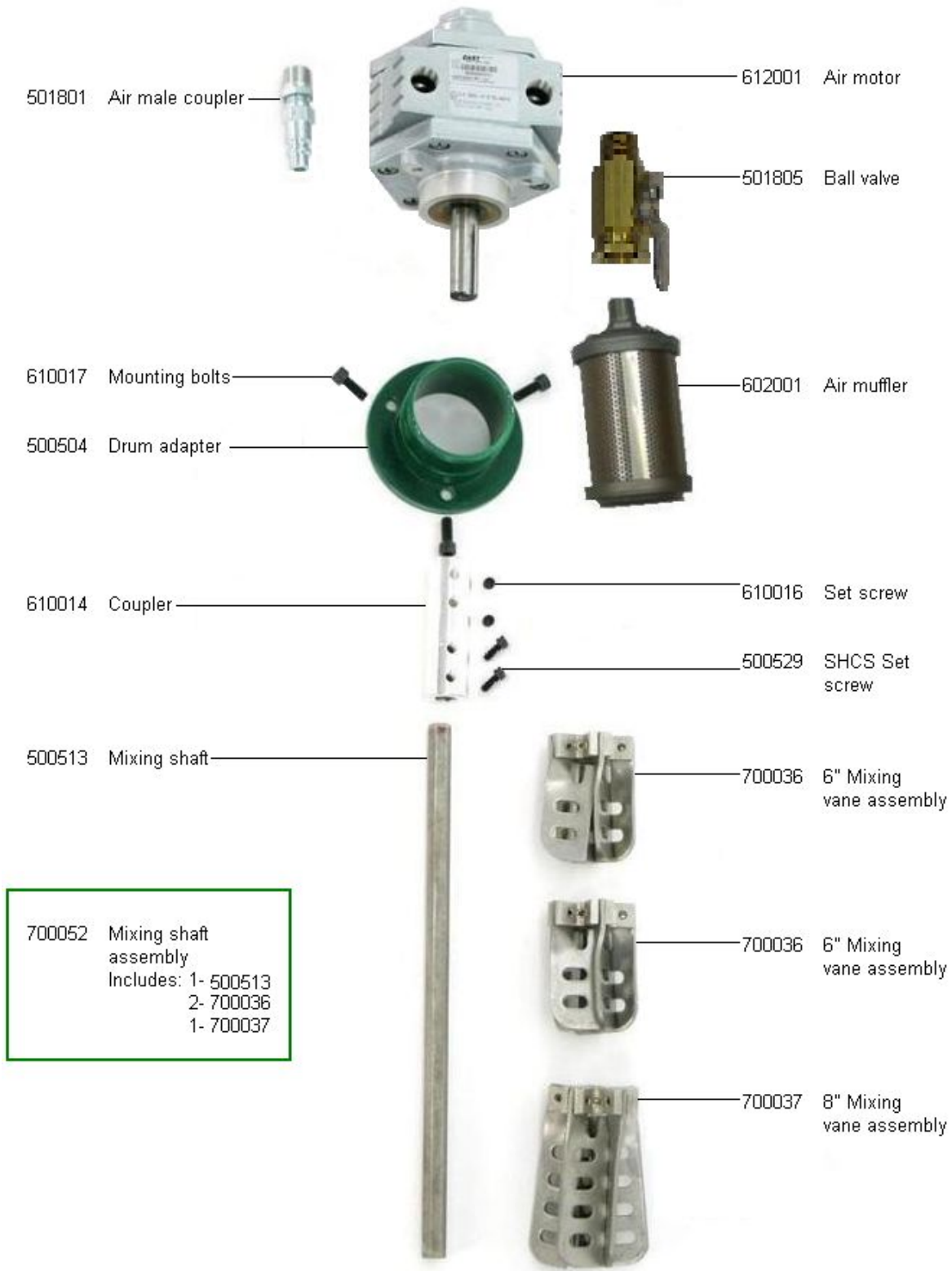

Parts illustration for air driven drum mixer (Tote length)  
 Part # 610072

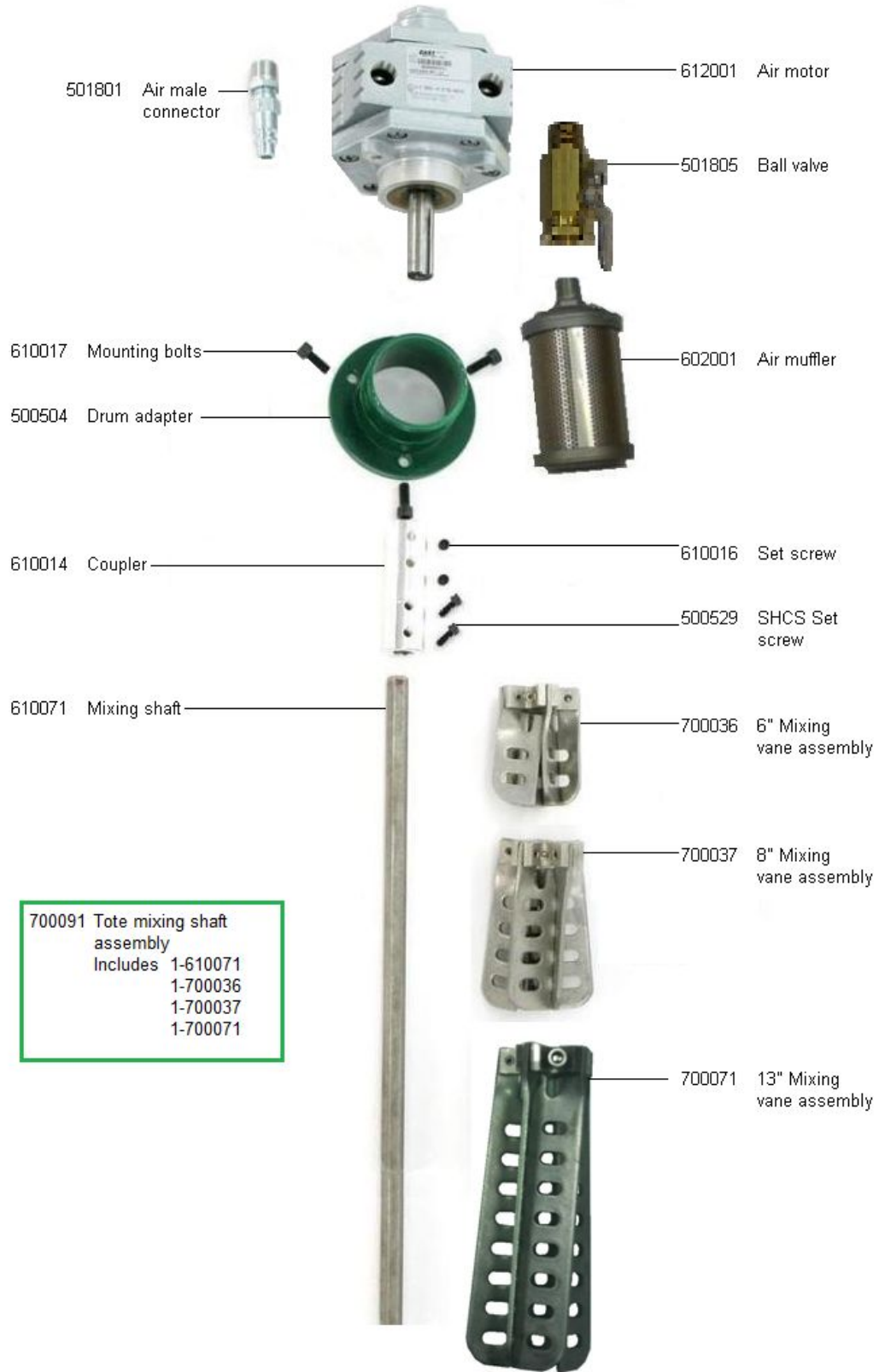

# 5.0 TECHNICAL SPECIFICATIONS

## 5.1 Performance graph

604001  
610072

### Air Operated Drum Mixer

International  
Pump  
Manufacturing



3107 142nd, Ave. E. # 106  
Sumner, WA 98390  
Tel: 253-863-2222  
Fax: 253-863-2223

www.ipmpumps.com

#### Technical Specifications

Minimum Operating Speed.....300 rpm  
Maximum Continuous Operating Speed.....1,000 rpm  
Maximum Intermittent Operating Speed.....1,200 rpm  
Minimum Recommended Viscosity.....None  
Maximum Recommended Viscosity.....2,000 cPs  
Blade Circle (collapsed).....2" dia.  
Air Inlet Port.....1/4 npt(f)  
Air Outlet Port (muffed).....1/4 npt(f)  
Wetted Parts.....Stainless Steel  
Weight.....11 lbs. (5 Kg.)

#### Air Consumption

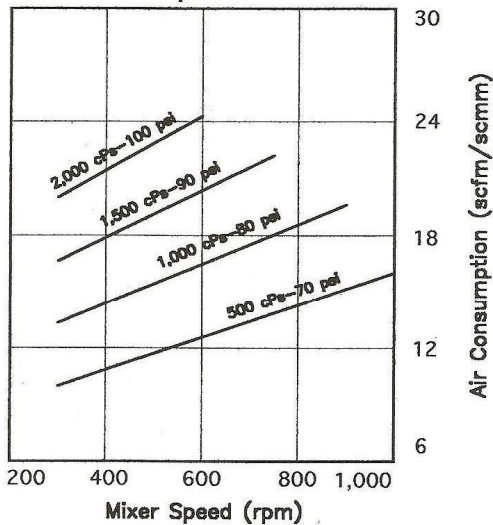

Choose mixer speed across bottom of chart and follow up to material viscosity. Approximate required air flow is shown at right. Required air pressure is shown beside viscosity, but will vary with material.

#### Higher viscosities require higher pressures

Every fluid has individual properties and characteristics. However, in general, higher viscosity fluids require more air pressure to turn the blades. A minimum air operating pressure of 40 psi is recommended for all fluids up to 500 cPs. For fluids between 500 cPs and 2,000 cPs, increase air pressure from 40 psi to 100 psi. To minimize air consumption, use the lowest air pressure possible to achieve the required mixing speed, and make small speed corrections with the throttling valve.

#### Mixer Operating Tips

##### Maintaining Particle Suspension

Initially, higher mixer speed is required to get particles in suspension. This typically can be done in 1/2 hour or less. Once the particles are in suspension, the mixer speed can be reduced to only that required to maintain suspension. To minimize air consumption, always use the lowest air pressure required to do the job, then use the throttling valve to maintain the speed.

##### "Meter out" for controllability

IPM drum mixers are shipped with the throttling valve assembled in the "meter out" flow direction. This is the flow direction recommended to maintain effective speed control, especially at low rpm conditions.

##### Muffler Maintenance

Periodic cleaning of the air motor muffler ensures the lowest possible air consumption, and makes for consistent speed control. Depending on usage and the condition of shop air, clean the muffler with solvent, and blow out trapped solids.

#### Dimensions

604001 55 gallon length

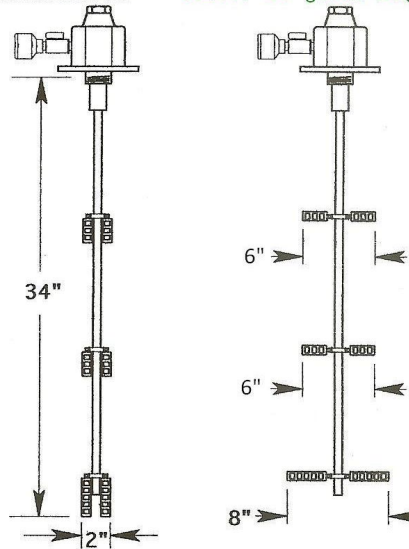

At rest, blades will fit through a 2" bung opening. While spinning, blades extend to the diameters shown.

#### Dimensions

610072 Tote length

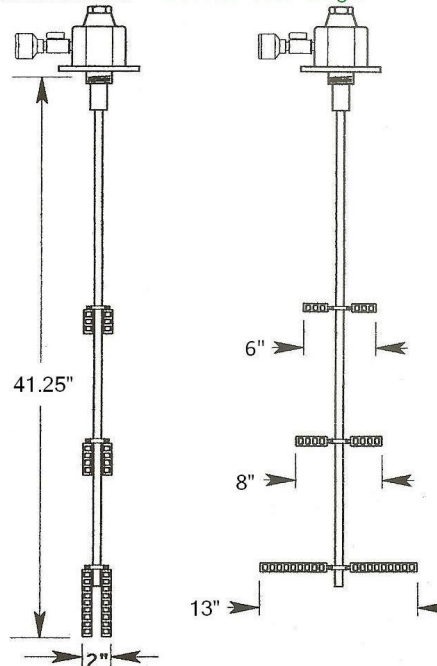



Post Office Box 97  
 Benlon Harbor, Michigan  
 Ph: 269/926-6171  
 Fax: 269/925-8288

Product Specifications

PART NUMBER: STD252

REVISION: F

*Gas 8/24/06*  
*AG 8/25/06*

Model Number	MAX. PRESS.		MAX. SPEED	HP	kW	Net Wt.	
	bar.	PSI				lbs.	kg
4AM-NRV-130	7.0	100	3,000 RPM	1.7	1.25	11	5.0
4AM-NRV-130C	7.0	100	3,000 RPM	1.7	1.25	11	5.0

SOUND LEVEL 87 dba MAX.

NORMAL AMBIENT +1° C. - 120° C.

RELATIVE HUMIDITY 0% - 100%

ENVIRONMENT HAZARDOUS AMBIENT COMBUSTIBLE  
GAS AND DUST +1°C TO +40°C

CONFORMS TO EUROPEAN STANDARD EN13463-1 NON-ELECTRICAL  
 EQUIPMENT FOR EXPLOSIVE ATMOSPHERES GROUP II CAT 2  
 (GAS & DUST), PROTECTED BY CONSTRUCTION (SURFACE TEMP RATED 135C)

TECHNICAL DATA SUBJECT TO CHANGE WITHOUT NOTICE.  
 DIMENSIONS ARE FOR REFERENCE ONLY  
 UNLESS OTHERWISE TOLERANCED.

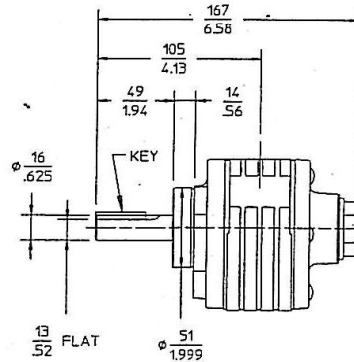
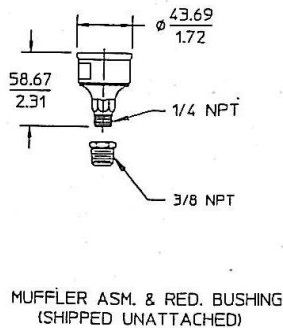
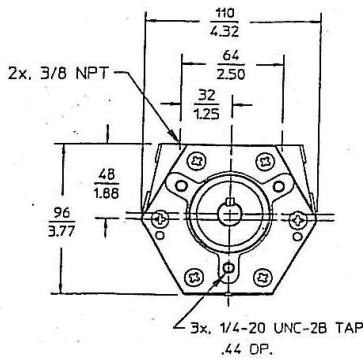
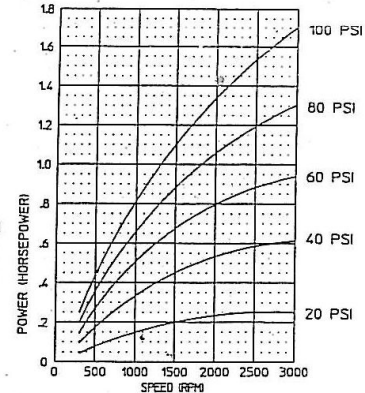
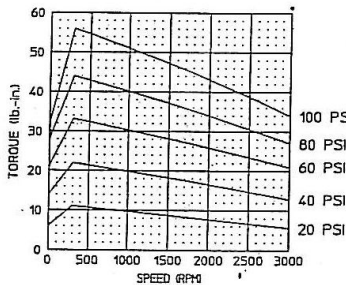
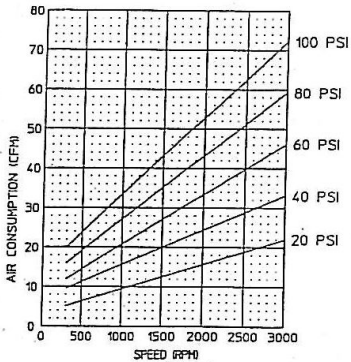
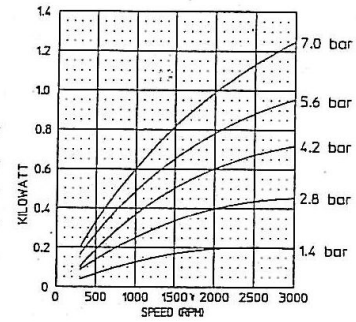
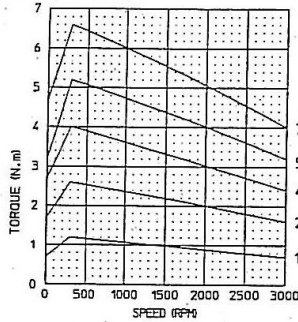
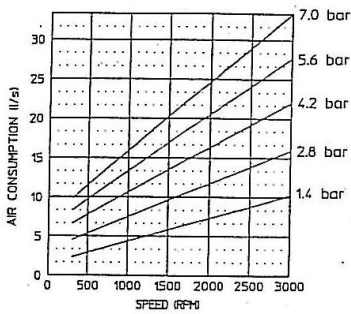

## 5.2 Operating parameters



• This air motor is ATEX approved and is designed for use in hazardous atmospheres. This air motor complies with the applicable standards and specifications and meet the requirements of the guidelines of the EC directive 94/9EC (ATEX 100a). They are intended to be used in zones 1 and 2 where explosive reactions are likely to occur. Use only belts with < 10<sup>9</sup> electrical leakage resistance to prevent static electrical problems. Always attempt to ground the air motor.

- Normal conditions: Operates at temperatures up to 250°F (121°C).
- Hazardous conditions: Operates at temperatures up to 104°F (40°C).
- Protect unit from dirt and moisture.
- Use ONLY compressed air to drive motor.
- Air lines connected to motor should be the same size or the next size larger than the **inlet** port for efficient output and speed control.
- Protect all surrounding items from exhaust air.
- Bearings are grease packed.

Estimated ball bearing life		
Model #	Shaft speed - RPM	Ball bearing life – Hours L/10
1AM	10,000	28,000
1UP	6,000	14,000
2AM	3,000	30,000
<b>4AM</b>	<b>3,000</b>	<b>14,000</b>
6AM	3,000	6,500
8AM	2,500	8,000
16AM	2,000	15,000

## **6.0 WARRANTY & DISCLAIMER**

### **WARRANTY**

International Pump Manufacturing, Inc. (hereafter designated IPM) warrants the equipment it manufactures to be free of defects in materials and workmanship for a period of one (1) year from the date of sale from IPM to an authorized IPM distributor or to the original end user and/or purchaser. IPM will, at its discretion, repair or replace any part of the equipment proven to be defective. This warranty applies only when the equipment is used for the intended purpose and has been installed, operated and maintained in accordance with written operating procedures.

A condition of the warranty is the prepaid return of the equipment to an authorized distributor of IPM who shall provide verification of the warranty claim. IPM will repair or replace free of charge any parts found and verified to be defective or damaged upon receipt of equipment. Shipping will be prepaid for the repaired or replaced parts under warranty. Should inspection of the equipment reveal no defects in material or workmanship repairs will be made at the standard IPM rate, which will include parts, inspection, labor, packaging and shipping.

The warranty does not apply nor shall IPM be liable for damage, operational wear, malfunction of equipment caused by improper installation, misuse, chemical abrasion or corrosion, operator negligence, accident, tampering or altering of equipment, lack of improper maintenance and/or by substitution of non-IPM parts. Additionally, IPM shall not be liable for nor does the warranty apply to operational wear, damage or malfunction caused by incompatibility of accessories, components, structures, equipment or materials not supplied by IPM. The warranty does not apply to nor will IPM be responsible for the improper operation, maintenance, design, manufacture, installation of components, accessories, equipment or structures not supplied by IPM.

The warranty is void unless the Warranty Registration Card is properly completed and returned to IPM within ONE (1) month of the date of the sale.

### **LIMITATIONS AND DISCLAIMERS**

This warranty is the sole and exclusive remedy for the purchaser. No other warranties, expressed or implied, warranties for fitness of purpose or merchantability, or non-contractual liabilities are made by IPM, including product liability, whether on negligence or a strict liability basis. Liability for directly special or non-contractual damages or loss is expressly excluded and denied. IPM's liability shall in no case exceed the amount of the purchase price.

IPM does not warrant and disclaims implied warranties of merchantability and fitness for a particular purpose, components, accessories, equipment, materials sold but not manufactured by IPM. These parts (valves, hoses, fittings, etc.) are subject to the provisions within the warranty of the actual manufacturer of these items. IPM will provide reasonable assistance with warranty claims on these items.



3107 142<sup>nd</sup> Avenue East, Suite 106  
Sumner, Washington

Telephone: (253)856-2222 Fax: (253)856-2223  
Website: [ipmpumps.com](http://ipmpumps.com)

Revised: 1 January 2011