

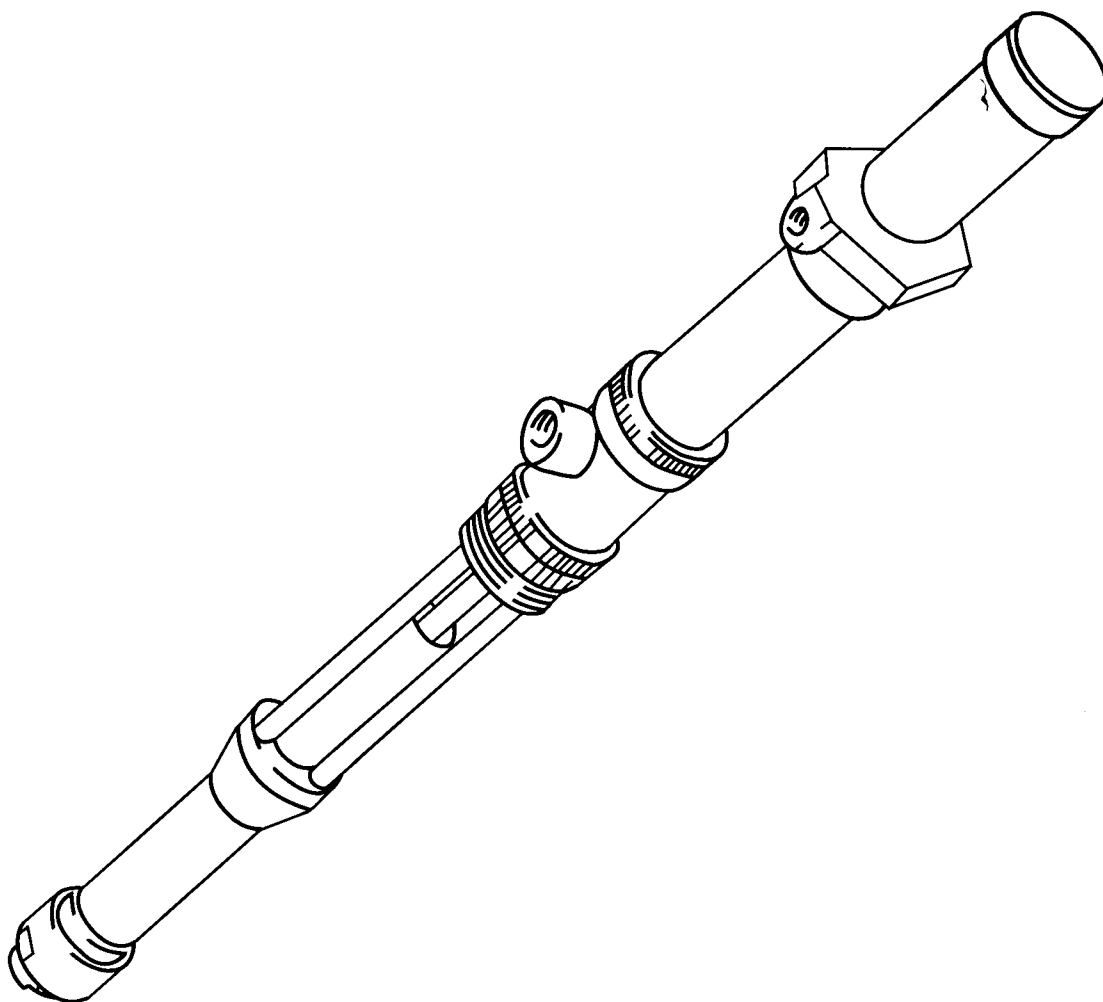

IP - 02
2:1 RATIO TRANSFER PUMP
OPERATING MANUAL



IPM, INC.

Manufactured by International Pump Manufacturing, Inc.

IP - 02
IP - 02S
2:1 RATIO TRANSFER PUMP
OPERATING MANUAL
with
PARTS IDENTIFICATION



INTERNATIONAL PUMP MANUFACTURING, INC.

25424 74TH AVENUE SOUTH
KENT, WASHINGTON 98032
U. S. A.

TEL: (253) 859 3882
FAX: (253) 859 3536

W A R N I N G

**THE EQUIPMENT DESCRIBED HEREIN MUST ONLY BE OPERATED
OR SERVICED BY PROPERLY TRAINED INDIVIDUALS, THOROUGHLY
FAMILIAR WITH THE OPERATING INSTRUCTIONS AND LIMITATIONS
OF THE EQUIPMENT.**

TABLE OF CONTENTS

1.0	SAFETY WARNINGS.....	1
2.0	INSTALLATION.....	4
2.1	Mounting Configurations.....	5
3.0	OPERATION.....	6
4.0	TROUBLESHOOTING.....	7
5.0	PARTS IDENTIFICATION.....	8
5.1	IP-02 & IP-02S(Air Motor).....	8
5.2	IP-02 Carbon Steel Drum Length Fluid Section.....	9
5.3	IP-02 Stainless Steel Drum Length Fluid Section.....	10
5.4	IP-02S Carbon Steel Stubby Fluid Section.....	11
5.5	IP-02S Stainless Steel Stubby Fluid Section.....	12
6.0	APPLICATIONS AND SPECIFICATIONS.....	13
7.0	WARRANTY & DISCLAIMER.....	15

1.0 SAFETY WARNINGS

Please read and observe all warnings contained in this operating manual before any attempt to operate the equipment.

Misuse of Equipment

Misuse of the equipment can cause serious injury. Use the equipment only for its intended purpose. Care should be taken to prevent over pressurization of the pump or accessories connected to it. Use only proper parts in good condition. Use the pump only with compatible fluids. Improper use or misuse of this equipment could result in fluid being splashed on the skin or in the eyes, serious bodily injury, property damage, fire or explosion.

Make daily checks on the equipment and repair damaged or worn parts immediately.

Do not alter this equipment. Doing so could cause it to malfunction and could cause serious injury.

MATERIALS AND FLUID COMPATIBILITY

Always ensure chemical compatibility of fluids and solvents with the wetted parts of the pump and any components. Check the fluid manufacturer's data sheets and specifications before using fluids or solvents in this pump.

PRESSURIZED HOSES

Because hoses are pressurized, they present a danger should the fluid escape at high pressure. This escaping fluid pressure can spray out and cause serious bodily injury or property damage. Ensure that hoses do not leak or rupture due to wear, misuse or damage.

Hoses should be handled properly. Do not pull on hoses to move the equipment around. Use the hoses only for fluids in which they are compatible, both for the inner liner of the hose and the outer covering. Use care not to exceed the temperature or pressure rating of the hose.

Before each use, ensure that the fluid couplings are tight and that the entire length of hose is not worn or damaged. Check the entire hose for leaks, bulging cover, damage, abrasion or cuts. These conditions may cause the hose to fail which could result in spraying of pressurized fluid on the skin or in the eyes and cause serious bodily injury or property damage.

PRESSURE SPECIFICATIONS

The maximum working fluid pressure of this equipment is 360 psi (25 bar) at a maximum incoming air pressure of 180 psi (12.5 bar). Ensure that all equipment and accessories used with this pump are rated to withstand the maximum working pressure of this pump. NEVER exceed the maximum working pressure of the pump or any device attached to the pump.

Procedure for Pressure Relief

In order to avoid the risk of serious bodily injury such as spraying fluid on the skin or in the eyes, or risk of injury from moving parts, the following procedure should be used. This procedure should be used when shutting down the pump, when servicing or repairing the pump or any part of the system, when replacing or cleaning components, or when pumping of fluid is stopped.

1. Close the air valve (D) to the pump.
2. Use the air bleed down valve (see installation instructions) to relieve the air pressure in the system.
3. Relieve the fluid pressure by holding a grounded metal pail in contact with the metal part of the fluid dispense valve (E) and slowly opening the valve.
4. With a container ready to catch the fluid open the drain valve (E) (see installation instructions).
5. It is a good practice to leave the drain valve (E) open until it is time to dispense fluid again.

If you are unsure that the fluid pressure has been relieved (due to a blockage in a component or a hose) be careful to relieve the pressure by slowly loosening the hose end coupling to allow the fluid pressure to escape slowly. After the pressure has been relieved, the fitting can be removed completely and any blockages removed.

Hazards from Fire or Explosion

Hazards exist when sparks can ignite vapors or fumes from flammable or combustible materials or other hazardous conditions (explosive dusts, etc.). These sparks can be created by connecting or disconnecting an electrical supply cord. Sparks can also be created from the static electricity generated by the flow of fluid through the pump and hose.

Every part of the equipment must be properly grounded to prevent static electricity from generating a spark and causing the pump or system to become hazardous. These sparks can cause a fire, explosion, and serious bodily injury or property damage. Ensure that the pump and all components and accessories are properly grounded and that electrical supply cords are connected or disconnected when these hazards exist.

Should any evidence of static electricity (sparks or small shocks while in contact with the equipment) exists, discontinue the operation immediately. Investigate the source of the static electricity and correct the grounding problem. Do not use the system until the grounding problem is repaired.

GROUNDING PROCEDURES

Grounding the pump and other dispensing equipment is necessary to minimize the possibility of sparks due to static electricity. Grounding must be in compliance with local electrical codes. Check with the local authorities for requirements in your area and with the type of equipment being used. Ensure that all of the following equipment is grounded:

1. Air Compressor: Follow the grounding procedures as recommended by the manufacturer.
2. Air Hoses: Use grounded air hoses.
3. Fluid Container used to supply the system: Grounding must be done according to local codes.
4. Pump: Follow the procedures included, referring to figure 1.
5. Fluid Hoses: Use grounded fluid hoses.
6. Dispensing Valve: The valve must be metal to conduct through the fluid hose to the pump which must be properly grounded.
7. Dispensing Point: Grounding must be done according to local codes.
8. Solvent Containers: Grounding must be done according to local codes. Use metal conductive pails that are properly grounded.

9. Grounding while dispensing, cleaning, or relieving: Maintain conductivity by firmly holding the metal part of the dispensing valve to the side of a grounded metal container.

FIGURE 1

GROUNDING THE PUMP:

Follow these procedures for grounding the pump. Loosen the lock screw (W) to allow insertion of one end of a 12 ga. (1.5 mm²) minimum size wire into the hole in the side of the lug (Z). Insert the wire (Y) and tighten the lock screw (W) securely. The other end of the ground wire must be secured to a true earth ground.

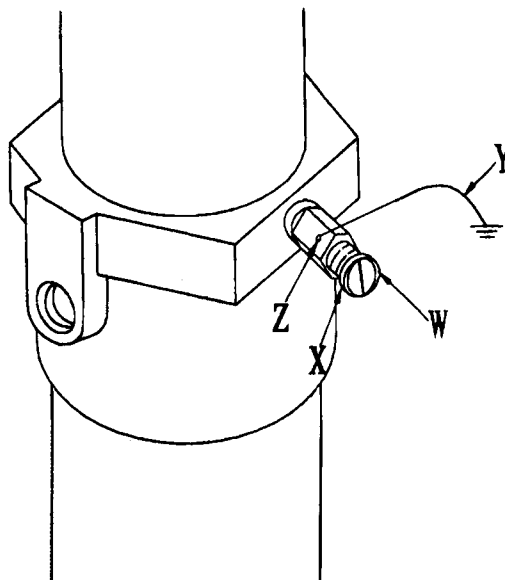

HOSE GROUNDING: It is very important that the hoses used for both air and the fluid be a grounding type and that this ground continuity is maintained. Regular checks of the hose ground resistance (with a resistance meter using a suitable range) and a comparison to the Manufacturer's Specification will ensure the ground is within specifications. If it is not within specified limits it should be replaced immediately.

SOLVENT CLEANING: While cleaning the system with solvent, hold the metal part of the dispensing valve in contact with a grounded metal pail to minimize the possibility of splashing fluid on the skin or in the eyes or static sparks. Use low fluid pressure for additional safety.

HAZARDS FROM MOVING PARTS: Use the Pressure Relief Procedure to prevent the pump from starting unintentionally. Take care that moving parts present a pinching hazard to fingers or other body parts. Stay clear of these moving parts when starting or operating the pump.

SAFETY STANDARDS: Safety standards have been established by the United States Government under the Occupational Safety and Health Act. These standards should be consulted as they apply to the hazards and type of equipment being used.

2.0 INSTALLATION

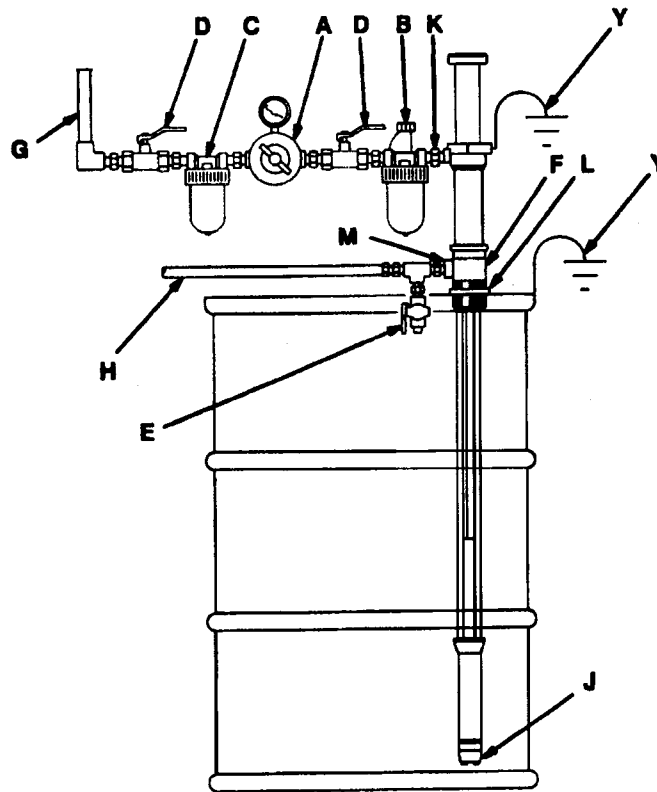

FIGURE 2

KEY

- A Pump Air Regulator
- B Air Line Lubricator
- C Air Line Filter
- D Bleed - Type Master Air Valve
(required, for pump)
- E Fluid Drain Valve (required)
- F 3/8npt(f) Fluid Return Inlet
- G Grounded Air Hose
- H Grounded Fluid Hose
- J Pump Fluid Inlet
- K 1/4npt(f) Pump Air Inlet
- L Bung adapter fitting
- M 3/4npt(f) Pump Fluid Outlet
- Y Ground Wire (required; see page 2 for
installation instructions)

Figure 2 depicts a typical installation provided as a guide for your reference. Select and install optional accessories required. Feel free to call an IPM representative or the IPM Technical Department for assistance.

Lower the pump with the bung adapter attached into the drum and turn the bung adapter into the bung hole. Tighten it. Keep the pump 1/2" (13 mm) above the bottom of the drum and tighten the bung adapter taper to hold the pump. To avoid a vacuum, unscrew the vent plug.

2. 1 Mounting Configurations

Install the necessary accessories in sequence using figure 2 as a guide. To minimize the risk of serious bodily injury such as spraying fluid on the skin or in the eyes; or risk of injury from moving parts, install the following accessories in your system:

1. Air Line lubricator(B). It provides air motor lubrication automatically when properly adjusted.
2. Bleed-off master air valve(D). This valve relieves air trapped within the system after the pump is stopped or the valve is closed. Air trapped between this valve and the pump can cause the pump to reciprocate unintentionally causing harm to the operator. For best results, install this valve close to the pump and downstream from the air regulator.
3. Air regulator(A). The air regulator controls pump speed and outlet pressure when the air pressure to the pump is adjusted. Install the regulator upstream from the bleed-off master air valve and close to the pump.
4. Air line filter(C). The filter, like any filter in an air line system, removes harmful dirt and moisture from the compressed air supply.
5. A second bleed-off air valve(D). When you need to service the pump, use this valve to isolate the air line accessories. Locate this valve upstream from all other air line accessories installed.
6. Fluid Drain Valve(E). The fluid drain valve (use a metal valve for grounding purposes) is installed to relieve fluid pressure in the pump, hose or the dispensing valve when the pump is stopped. The relief of pressure by the dispensing valve, at times is inadequate if there is a clog or restricted passage in the hose or the dispensing valve. Use care when removing a fluid line that is suspected of being blocked. Loosen the fitting very slowly and allow the pressure to dissipate before removing the fitting.

Connect a grounded air supply hose to supply air to the pump's 1/4 npt(f) air inlet(K). Connect a grounded fluid hose(H) to the fluid outlet(M) 3/4 npt(f). Remove the pipe plug and connect a fluid return line to the 3/8 npt(f) return port(F) in a recirculating system.

Ground the pump and all accessories before operation. Observe all OSHA regulations and other safety regulations.

WARNING:

A bleed-off master air valve(D) and a fluid drain valve (E) are required in your system. These valves reduce the risk of serious bodily injury including spraying fluid in the eyes or on the skin, and injury from moving parts if you are adjusting or servicing the pump.

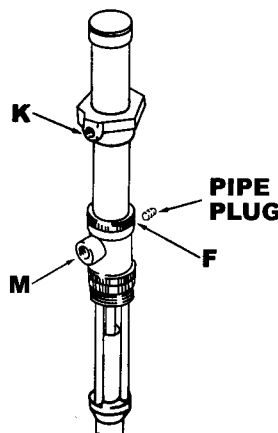

3.0 OPERATION

Procedure for Pressure Relief

In order to avoid the risk of serious bodily injury such as spraying fluid on the skin or in the eyes, or risk of injury from moving parts, the following procedure should be used. This procedure should be used when shutting down the pump, when servicing or repairing the pump or any part of the system, when replacing or cleaning components, or when pumping of fluid is stopped.

1. Close the air valve to the pump.
2. Use the air bleed-off valve (see installation instructions) to relieve the air pressure in the system.
3. Relieve the fluid pressure by slowly opening the drain valve. (Use a grounded metal pail in contact with the metal part of the fluid drain valve)
4. With a container ready, catch the fluid by opening the drain valve (see installation instructions).
5. It is good practice to leave the drain valve open until it is time to dispense fluid again.

If you are unsure if the fluid pressure has been relieved (due to a blockage in a component or a hose), carefully relieve the pressure by slowly loosening the hose end coupling to allow the fluid pressure to escape slowly. After the pressure has been relieved, the fitting can be removed completely and any blockages removed.

Start up and Adjustment of the pump

Ensure that installation is fully completed before proceeding to start up operations.

1. Ensure that the air regulator (A) and the bleed-off master air valve (D) are closed.
2. Into a grounded metal container, open the dispensing valve slowly. Ensure metal-to-metal contact between the container and the valve.
3. Open the bleed-off air valve and adjust the air regulator (A) slowly for pressure just enough to start the pump. This is to prime the system. After all the air has been expelled from the lines, close the dispensing valve. During the priming of the pump, the pump should run when the dispensing valve is opened and stop when the valve is closed.
4. Turn the air regulator slowly until sufficient flow from the dispensing valve is achieved. Remember to run the pump always at the lowest possible speed necessary to achieve what is desired. Never exceed the maximum working pressure of any component in the system.
5. The pump should not be left to run without fluid to pump. When running empty, the pump will accelerate and probably damage itself. During operation, should the pump be found running too fast, stop it immediately and check the fluid supply. Is the fluid level in the drum too low or empty? If air has gone into the system, do a priming procedure. Ensure that all air has been expelled from the lines before operating again. Flush the pump or leave it filled with a compatible solvent when not in use.
6. Always follow the Pressure Relief Procedure when the pump will be shut down for any extended period of time or during system shut off at the end of the day.

Daily Maintenance Check

1. Ensure sufficient lubricant in the air lubricator.
2. Drain the moisture trapped in the air filter.

Clean and flush the pump thoroughly with appropriate cleaning fluid to obtain maximum service life of the equipment.

4.0 TROUBLESHOOTING

Problem	Causes	Recommended Solutions
Pump does not operate.	<p>Air supply or pressure is inadequate. Air lines restricted.</p> <p>Dispensing valve is not open or it is clogged.</p> <p>Clogged fluid lines, valves, hoses, etc</p> <p>Damaged air motor.</p> <p>Depleted or exhausted fluid supply.</p>	<p>Increase air pressure. Check for any restrictions in air line.</p> <p>Open and/or clear valve.</p> <p>Follow pressure relief procedure to clear obstruction.</p> <p>Service air motor. Replace parts as necessary.</p> <p>Refill fluid. Prime system or flush it.</p>
Non-stop air exhaust.	Worn or damaged air motor gasket, packing, seal, etc	Service air motor. Replace parts as necessary.
Erratic pump operation.	<p>Intake valve or packings worn.</p> <p>Intake valve is not completely closed.</p>	<p>Refill fluid. Prime system or flush it.</p> <p>Clear obstruction and service pump. Replace parts as necessary.</p>
Low output on upstroke.	Clogged or worn piston valve.	<p>Clear obstruction and service pump.</p> <p>Replace parts as necessary.</p>
Low output on down stroke.	Clogged or worn intake valve.	<p>Clear obstruction and service pump.</p> <p>Replace parts as necessary.</p>
Low output on both strokes.	<p>Restriction in air lines or air pressure low.</p> <p>Closed or clogged valves.</p> <p>Fluid supply is insufficient or exhausted.</p> <p>Obstructions in fluid lines, hoses, valves, etc.</p>	<p>Increase air pressure or supply.</p> <p>Open valve or clear valve.</p> <p>Refill fluid. Prime system or flush it.</p> <p>Follow pressure relief procedure to clear obstruction.</p>

5.0 PARTS IDENTIFICATION

5.1 Part List for IP-02(02-204-722)AIR MOTOR

Part List for IP-02S(02-223-953)AIR MOTOR

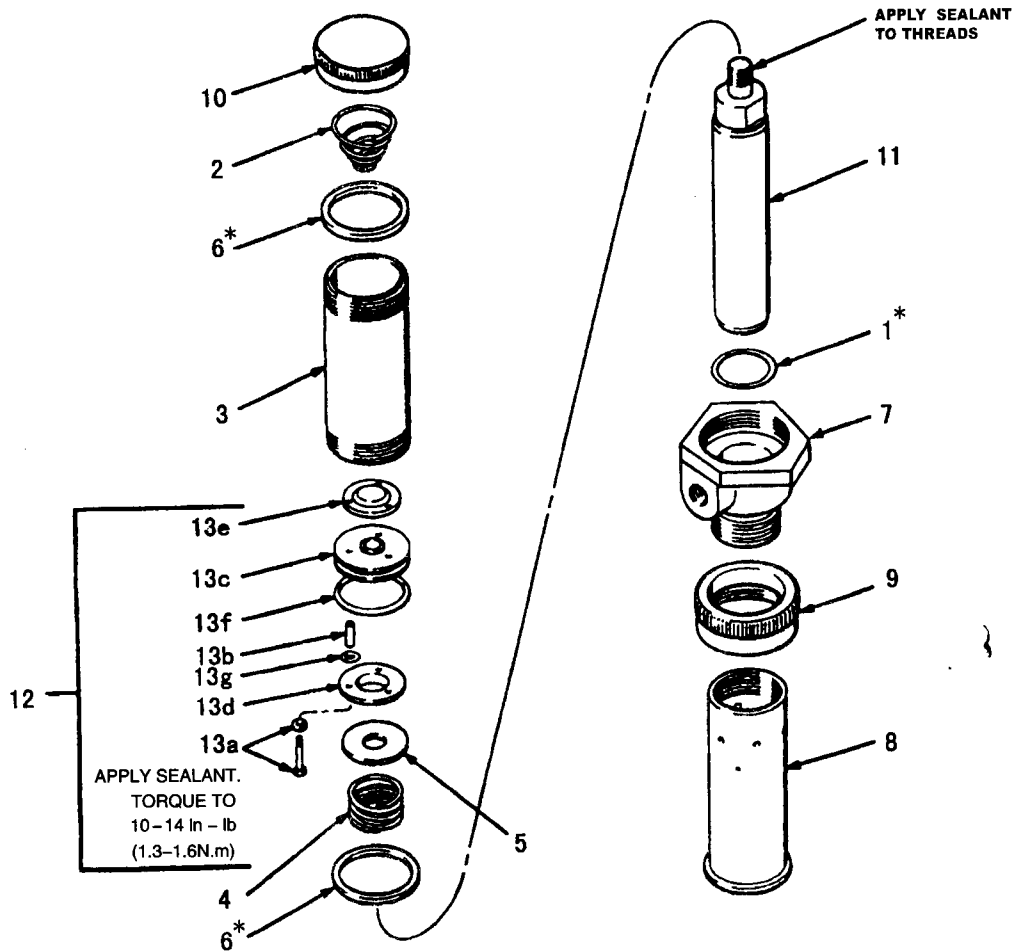

REF NO.	PART NO.	DESCRIPTION	QTY	REF NO.	PART NO.	DESCRIPTION	QTY
1*	02-156-698	O-RING	1	10	02-204-465	AIR CYLINDER CAP	1
2	02-157-630	SPRING, conical	1	11	02-204-723	ROD, piston	1
3	02-157-632	AIR CYLINDER (for model IP02; 02-204-722)	1	12	02-220-168	AIR VALVE & PISTON ASSY (includes items 13a to 13g)	1
	02-186-565	AIR CYLINDER (for Model IP02S; 02-223-953)	1	13a	02-220-884	SCREW, SHCS (6-32X1" with copper gasket)	3
4	02-157-633	SPRING, compression	1	13b	02-181-485	SPACER	3
5	02-157-872	WASHER, valve	1	13c	02-189-210	PISTON, air	1
6*	02-158-109	GASKET, rubber	2	13d	02-181-487	PLATE, intake	1
7	02-161-770	BASE, air motor	1	13e	02-162-729	PLATE, exhaust	1
8	02-161-771	HOUSING, connecting rod	1	13f	02-108-357	O-RING	1
9	02-161-772	RING, connecting	1	13g	02-108-358	O-RING	3

* These parts are included in 02-990-053 Air Motor Repair Kit.

5.2 Part List for IP-02(02-208-177)(Fluid Section for Carbon Steel Drum Length)

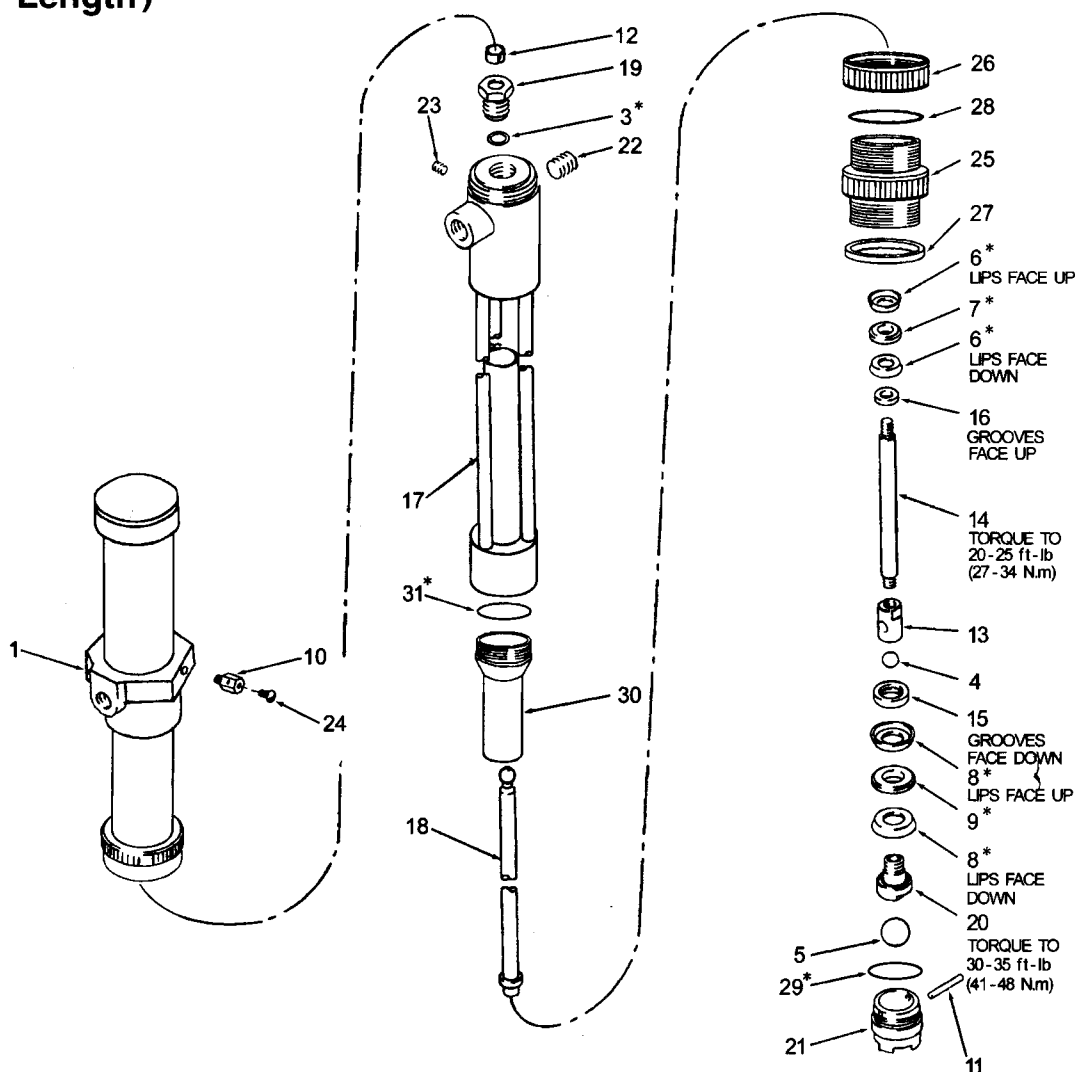

REF NO.	PART NO.	DESCRIPTION	QTY	REF NO.	PART NO.	DESCRIPTION	QTY
1	02-204-722	AIR MOTOR	1	15	02-169-295	WASHER, back-up	1
2	02-208-197	DISPLACEMENT PUMP ASSY	1	16	02-169-296	WASHER, back-up	1
		Includes items 3-31		17	02-990-017	FRAME, displacement pump	1
3*	02-102-596	O-Ring, Teflon	1	18	02-208-198	ROD, upper connecting	1
4	02-100-084	BALL, piston valve	1	19	02-169-298	RETAINER, packing	1
5	02-100-279	BALL, intake valve	1	20	02-208-201	BODY, piston	1
6*	02-161-788	CUP PACKING, Teflon	2	21	02-208-202	HOUSING, intake valve	1
7*	02-186-647	BEARING, Piston	1	22	02-100-040	PLUG, pipe; 3/8 npt	1
8*	02-161-793	CUP PACKING, Teflon	2	23	02-103-147	PLUG, pipe; 1/16npt	1
9*	02-186-648	BEARING, Piston	1	24	02-104-582	SCREW, M5X10	1
10	02-104-029	LUG, grounding	1	25	02-990-359-A	ADAPTER, BUNG	1
11	02-164-250CS	PIN, ball stop	1	26	02-990-359-B	CAP, bung adapter	1
12	02-166-564	BEARING	1	27	02-990-359-C	GASKET	1
13	02-169-293	HOUSING, Piston valve	1	28	02-990-359-D	O-RING	1
14	02-169-294	ROD, lower connecting	1	29*	02-990-032	O-RING	1
				30	02-990-017-5	CYLINDER	1
				31*	02-990-038	O-RING	1

* These parts are included in Repair Kit 02-990-051

5.3 Part List for IP-02(02-226-040)(Fluid Section for Stainless Steel Drum Length)

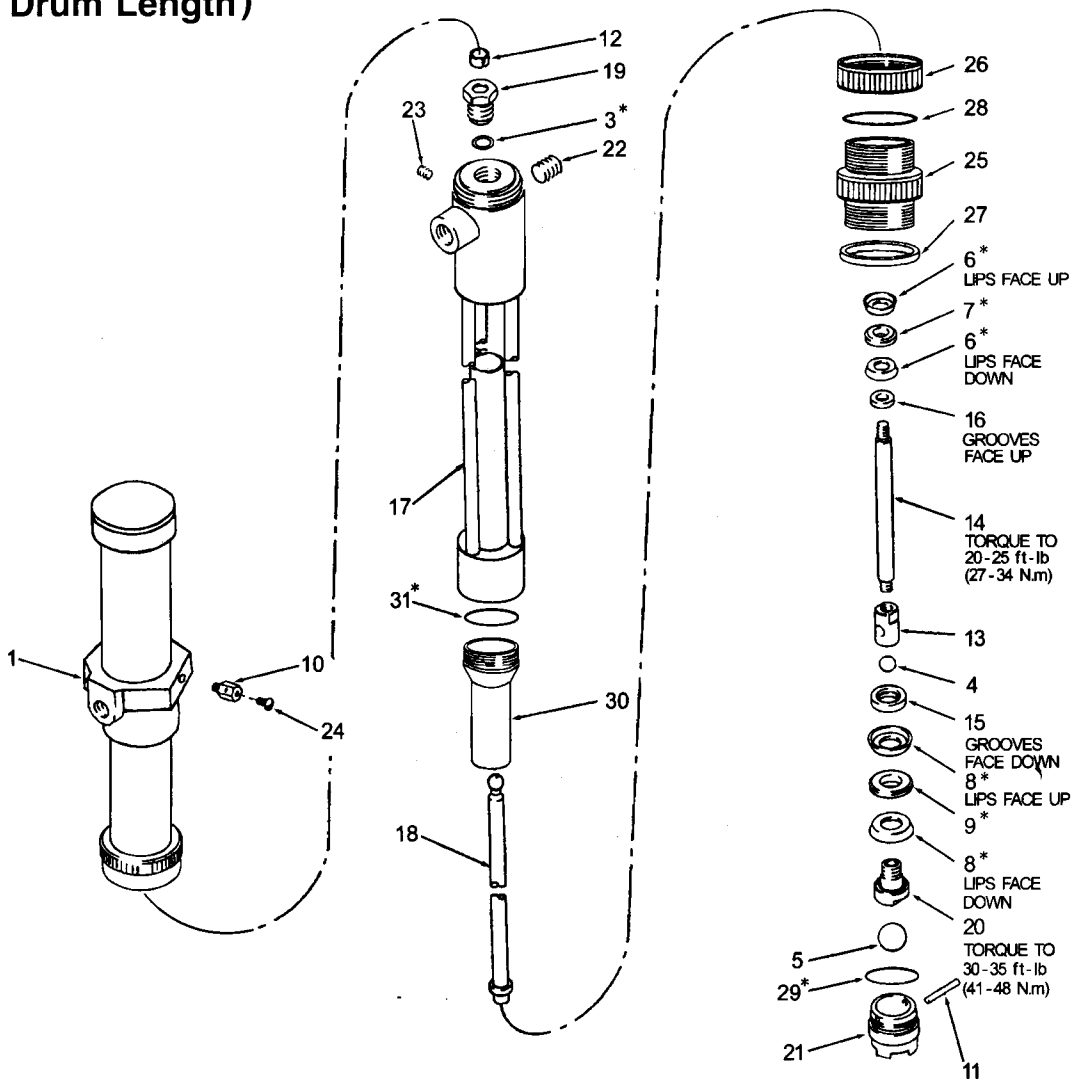

REF NO.	PART NO.	DESCRIPTION	QTY	REF NO.	PART NO.	DESCRIPTION	QTY
1	02-204-722	AIR MOTOR	1	15	02-161-792	WASHER, back-up	1
2	02-204-724	DISPLACEMENT PUMP ASSY	1	16	02-162-238	WASHER, back-up	1
		Includes items 3-31		17	02-990-041	FRAME, displacement pump	1
3*	02-102-596	O-Ring, Teflon	1	18	02-204-885	ROD, upper connecting	1
4	02-101-750	BALL, piston valve	1	19	02-990-043	RETAINER, packing	1
5	02-101-917	BALL, intake valve	1	20	02-161-795	BODY, piston	1
6*	02-161-788	CUP PACKING, Teflon	2	21	02-164-251	HOUSING, intake valve	1
7*	02-186-647	BEARING, Piston	1	22	02-101-748	PLUG, pipe; 3/8 npt	1
8*	02-161-793	CUP PACKING, Teflon	2	23	02-990-045	PLUG, pipe; 1/16npt	1
9*	02-186-648	BEARING, Piston	1	24	02-104-582	SCREW, M5X10	1
10	02-104-029	LUG, grounding	1	25	02-990-359-A	ADAPTER, BUNG	1
11	02-164-250	PIN, ball stop	1	26	02-990-359-B	CAP, bung adapter	1
12	02-166-564	BEARING	1	27	02-990-359-C	GASKET	1
13	02-161-791	HOUSING, Piston valve	1	28	02-990-359-D	O-RING	1
14	02-162-239	ROD, lower connecting	1	29*	02-990-032	O-RING	1
				30	02-990-041-6	CYLINDER	1
				31*	02-990-038	O-RING	1

* These parts are included in Repair Kit 02-990-051

5.4 Part List for IP-02S(02-223-954CS)(Fluid Section for Carbon Steel Stubby)

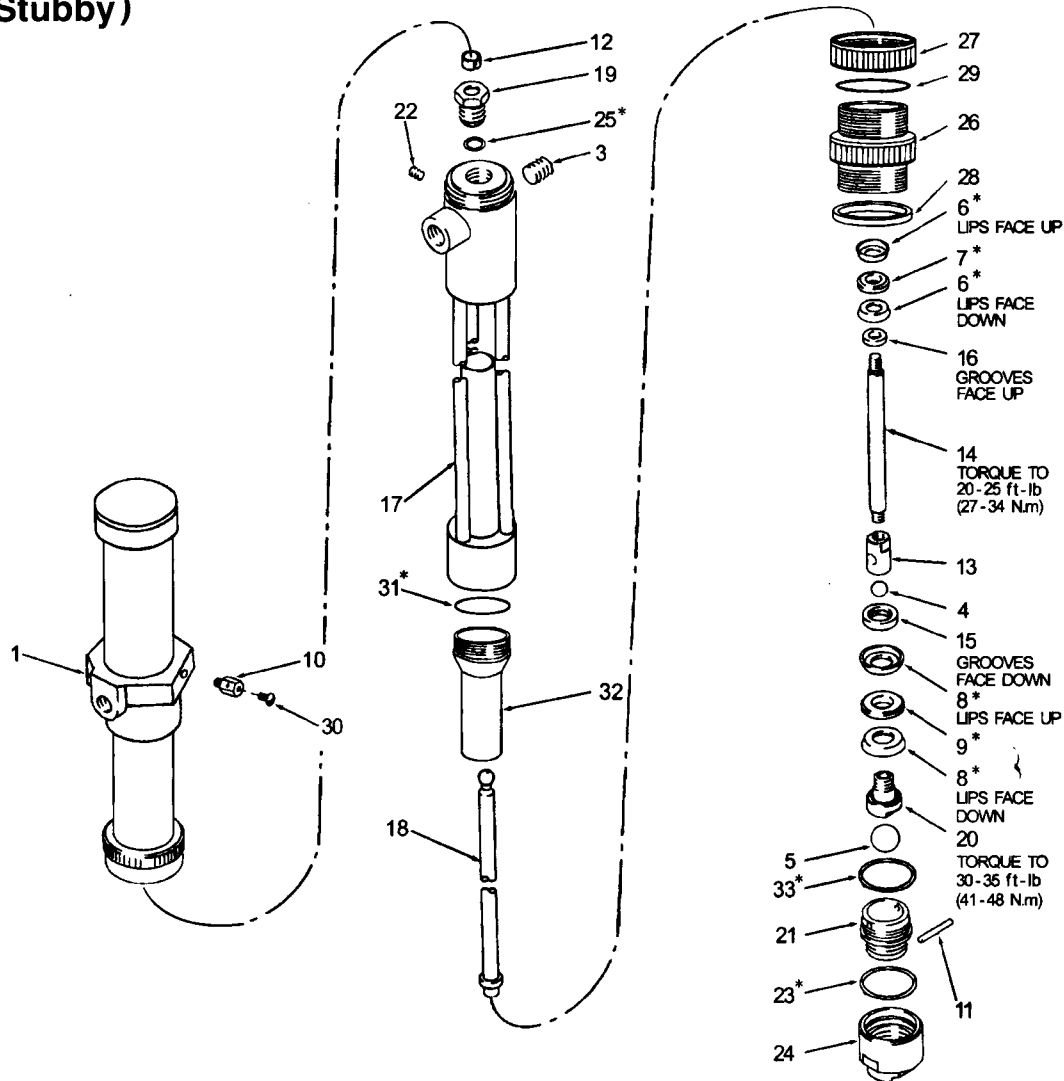

REF NO.	PART NO.	DESCRIPTION	QTY
1	02-223-953	AIR MOTOR	1
2	02-223-955CS	DISPLACEMENT PUMP ASSY	1
		Includes items 3-33	
3	02-100-040	PLUG, pipe 3/8npt	1
4	02-100-084	BALL, piston valve	1
5	02-100-279	BALL, intake valve	1
6*	02-161-788	CUP PACKING, Teflon	2
7*	02-186-647	BEARING, piston	1
8*	02-161-793	CUP PACKING, Teflon	2
9*	02-186-648	BEARING, Piston	1
10	02-104-029	LUG, grounding	1
11	02-164-250CS	PIN, ball stop	1
12	02-166-564	BEARING	1
13	02-169-293	HOUSING, Piston valve	1
14	02-186-569CS	ROD, lower connecting	1
15	02-169-295	WASHER, back-up	1

REF NO.	PART NO.	DESCRIPTION	QTY
16	02-169-296	WASHER, back-up	1
17	02-990-018	FRAME, displacement pump	1
18	02-223-957CS	ROD, upper connecting	1
19	02-169-298	RETAINER, packing	1
20	02-208-201	BODY, piston	1
21	02-166-609CS	HOUSING, intake valve	1
22	02-103-147	PLUG, pipe; 1/16npt	1
23*	02-166-612	O-RING, teflon	1
24	02-188-037CS	ADAPTER, intake	1
25*	02-102-596	O-RING, Teflon	1
26	02-990-359-A	ADAPTER,BUNG	1
27	02-990-359-B	CAP,bung adapter	1
28	02-990-359-C	GASKET	1
29	02-990-359-D	O-RING	1
30	02-104-582	SCREW,M5X10	1
31*	02-990-038	O-RING	1
32	02-990-018-5	CYLINDER	1
33*	02-990-032	O-RING	1

* These parts are included in Repair Kit 02-990-052

5.5 Part List for IP-02S(02-223-954)(Fluid Section for Stainless Steel Stubby)

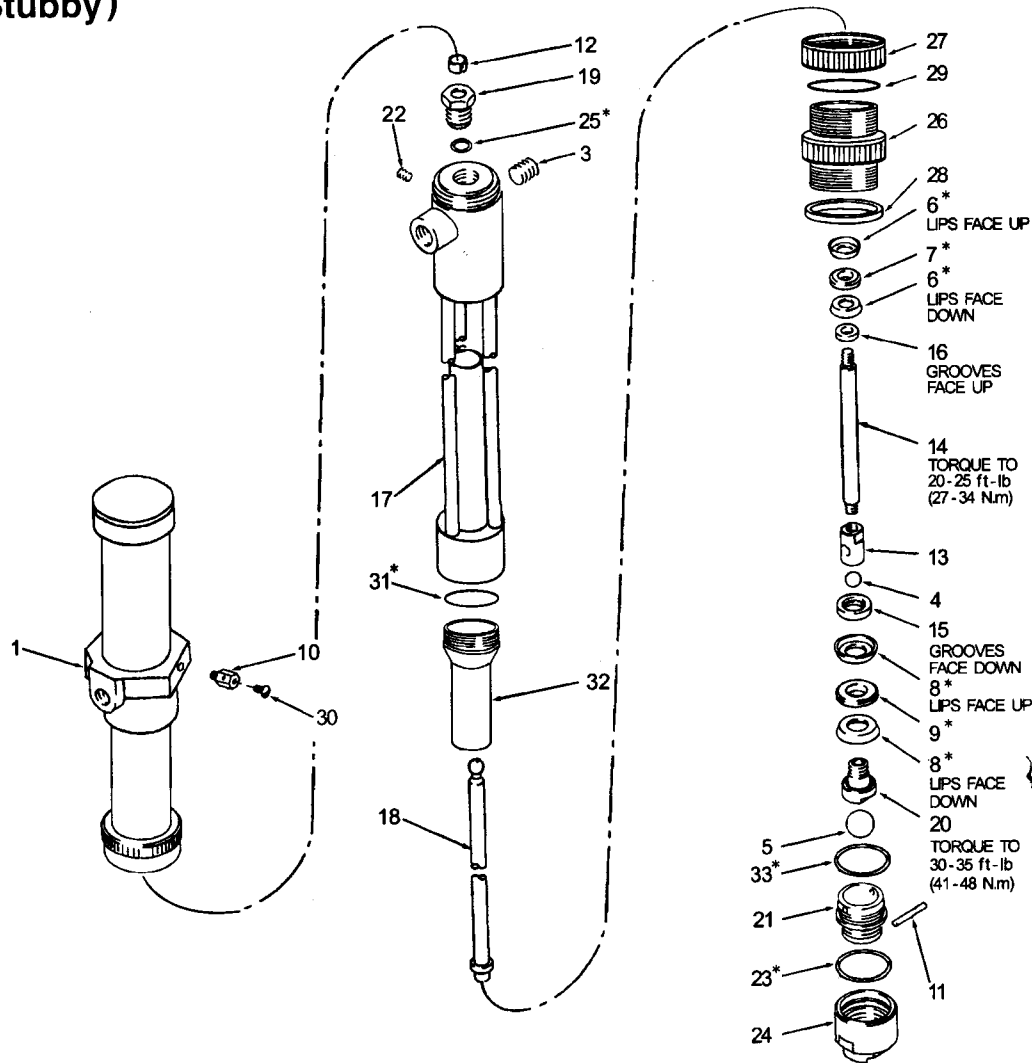

REF NO.	PART NO.	DESCRIPTION	QTY	REF NO.	PART NO.	DESCRIPTION	QTY
1	02-223-953	AIR MOTOR	1	16	02-162-238	WASHER, back-up	1
2	02-223-955	DISPLACEMENT PUMP ASSY	1	17	02-990-042	FRAME, displacement pump	1
		Includes items 3-33		18	02-223-957	ROD, upper connecting	1
3	02-101-748	PLUG, pipe 3/8npt	1	19	02-990-043	RETAINER, packing	1
4	02-101-750	BALL, piston valve	1	20	02-161-795	BODY, piston	1
5	02-101-917	BALL, intake valve	1	21	02-166-609	HOUSING, intake valve	1
6*	02-161-788	CUP PACKING, Teflon	2	22	02-990-045	PLUG, pipe; 1/16npt	1
7*	02-186-647	BEARING, piston	1	23*	02-166-612	O-RING, teflon	1
8*	02-161-793	CUP PACKING, Teflon	2	24	02-188-037	ADAPTER, intake	1
9*	02-186-648	BEARING, Piston	1	25*	02-102-596	O-RING, Teflon	1
10	02-104-029	LUG, grounding	1	26	02-990-359-A	ADAPTER,BUNG	1
11	02-164-250	PIN, ball stop	1	27	02-990-359-B	CAP,bung adapter	1
12	02-166-564	BEARING	1	28	02-990-359-C	GASKET	1
13	02-161-791	HOUSING, Piston valve	1	29	02-990-359-D	O-RING	1
14	02-186-569	ROD, lower connecting	1	30	02-104-582	SCREW,M5X10	1
15	02-161-792	WASHER, back-up	1	31*	02-990-038	O-RING	1
				32	02-990-042-3	CYLINDER	1
				33*	02-990-032	O-RING	1

* These parts are included in Repair Kit 02-990-052

6.0 APPLICATIONS AND SPECIFICATIONS

(a) Recommended Applications Chart

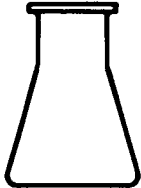
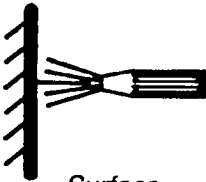
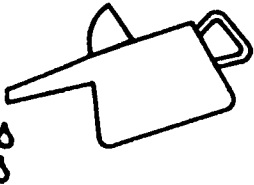
Industry	Application	Viscosity Range(CPS)
 Chemical	Alcohol	0 – 100
	Dye	0 – 1000
	Methyl Chloride	0 – 200
	Solvents	0 – 500
 Surface Finishing Material	Paint (Latex)	100 – 1,000
	Paint (Oil base)	100 – 800
	Sealer (Wood)	100 – 800
	Stain (Oil base)	100 – 1,000
 Lubricant	Anti-Freeze	30 – 100
	Die Lubricant	30 – 50
	Gear Oil	200 – 1000
	Lubricant	100 – 1500
	Mold Release Agent	30 – 100
	Oil	100 – 500

(b) Technical Specifications

Fluid Ratio	2: 1
Max. Output Flow (intermittent) (stubby)	2. 5 gpm(9. 5 lpm)
Max. Output Flow (intermittent) (drum)	3. 75 gpm(11. 7 lpm)
Max. Output Flow (continuous) (stubby)	2. 0 gpm(7. 6 lpm)
Max. Output Flow (continuous) (drum)	2. 5 gpm(9. 5 lpm)
Maximum Output Pressure	360 psi(24. 8 bar)
Maximum Air Input Pressure	180 psi(12. 4 bar)
Air Inlet Port	1/4 npt(f)
Fluid Outlet Port	3/4 npt(f)
Fluid Inlet Port (stubby)	3/4 npt(f)
Rod & Piston Packings	Teflon®
Other Seals	Viton®
Rod & Cylinder	See Parts List for Pump Materials
Other Wetted Parts	See Parts List for Pump Materials
Weight stubby/drum	14 lbs. (6.4 kg.) / 16 lbs. (7.3 kg.)

(c) Performance

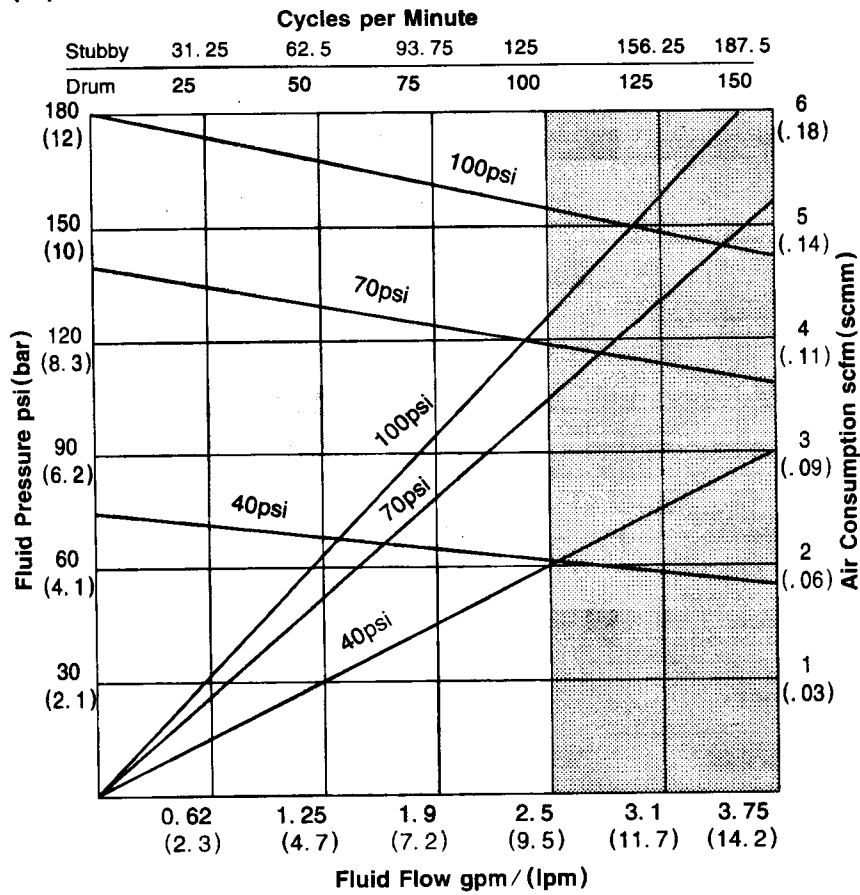

Model Numbers

Bare Stubby: IP-02S

Bare Drum: IP-02

Bung Adapter*: 02-990-359

* One supplied with pump. Additional adapters can be used in new material drums for minimal interruption of operation during drum change-over. Adapters have internal seal to allow nitrogen blanket to prevent moisture contamination.

(d) Pump Dimensions

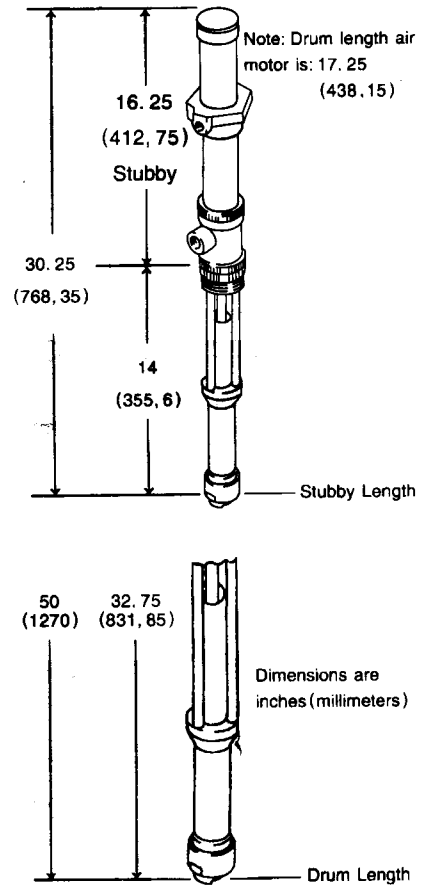

How to Read Performance

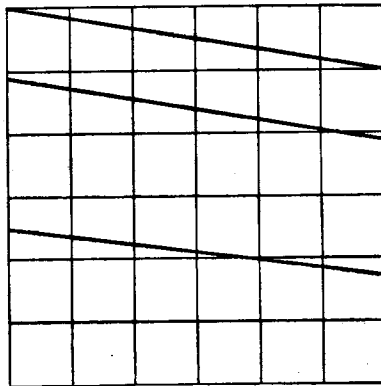

Pressure/Flow

1. Locate required flow along bottom edge of chart.
2. Follow vertically to bold line for input air pressure.
3. Follow horizontally to left edge of chart to read maximum available fluid pressure.

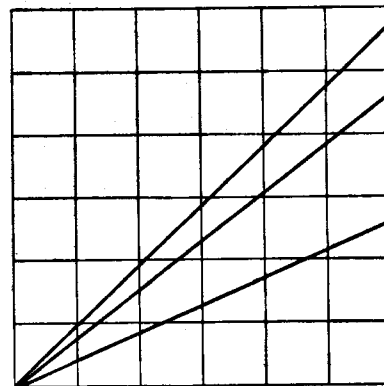

Air Consumption

1. Locate fluid flow along bottom edge of chart.
2. Follow vertically to bold line for input air pressure.
3. Follow horizontally to right edge of chart to read air consumption.

7.0 WARRANTY AND DISCLAIMER

WARRANTY

International Pump Manufacturing, Inc. (IPM) warrants the equipment it manufactures to be free of defects in material and workmanship for a period of one year from the day of sale by an authorized IPM distributor to the original purchaser. IPM will at its discretion repair or replace any part of the equipment proven to be defective. This warranty applies only when the equipment is used for the intended purpose and has been installed, operated and maintained in accordance with the written recommendations.

A condition of the warranty is the prepaid return of the equipment to an authorized distributor of IPM who shall provide verification of the warranty claim. IPM will repair or replace, free of charge, any parts found and verified to be defective. Transportation will be prepaid for the repaired or replaced parts under warranty. Should the inspection of the equipment not reveal any defect in material or workmanship, repairs will be made, at standard charges, which include parts, labor and transportation.

The warranty does not apply to, nor will IPM be liable for, damage, wear, or malfunction of equipment caused by improper installation, misuse, abrasion, corrosion, negligence, accident, tampering, lack of, or improper maintenance, or by substitution of non-IPM parts. Additionally IPM shall not be liable for accessories, components, structures, equipment or materials not supplied by IPM. The warranty does not apply to, nor will IPM be responsible for, the improper operation, maintenance, design, manufacture, installation of components, accessories, equipment or structures not supplied by IPM.

The warranty is void unless the Warranty Registration Card is properly completed and returned to International Pump Manufacturing, Inc. within ONE month of the date of the sale.

LIMITATIONS AND DISCLAIMERS

This warranty is the sole and exclusive remedy for the purchaser. No other warranties (expressed or implied), including warranties for fitness of purpose or merchantability, or non-contractual liabilities are made, including product liability, whether on negligence or strict liability basis. Liability for direct, special or consequential damages or loss, is expressly excluded and denied. IPM's liability shall in no case exceed the amount of the purchase price.

IPM does not warrant and disclaims implied warranties of merchantability and fitness for a particular purpose, components, accessories, equipment, materials sold but not manufactured by IPM. These items (switches, hoses, etc.) are subject to the provisions of the warranty of the manufacturer of these items. IPM will provide reasonable assistance with warranty claims on these items.

Headquarters:

IPM

INTERNATIONAL PUMP MANUFACTURING, INC.

25424 74th Avenue South

Kent, Washington 98032

U. S. A.

Tel: (253) - 859 3882

Fax: (253) - 859 3536
