

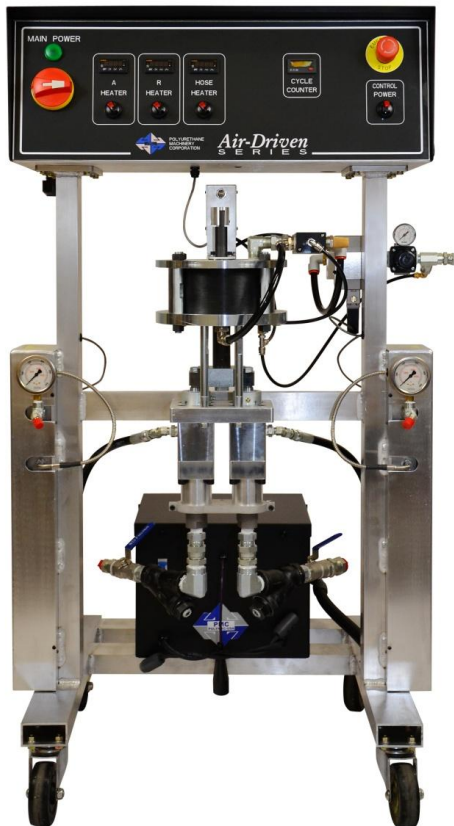

POLYURETHANE MACHINERY CORPORATION



PA-25/PAX-25 Proportioners

For Professional Use Only
Not approved for use in European
explosive atmosphere locations

Electrical Diagrams
Ref. # MN-06003
REVISION 2.0
May 2, 2016

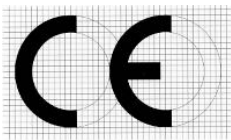

Polyurethane Machinery Corp.

Corporate: 1 KOMO Drive, Lakewood, NJ 08701
Manufacturing: 2 KOMO Drive, Lakewood, NJ 08701
Phone: 732-415-4400 Fax: 732-364-4025

<http://www.polymac-usa.com>



Before installing the PA Series Proportioner and start-up, carefully read all the technical and safety documentation included in this manual. Pay special attention to the information in order to know and understand the operation and the conditions of use of the PA Series Proportioner. All of the information is aimed at improving user safety and avoiding possible breakdowns from the incorrect use of the PA Series Proportioner.

TABLE OF CONTENTS

WARRANTY	1
SAFETY AND HANDLING	3
220 VAC.....	5
Component Identification	5
Console Assembly	5
Front Panel	6
Bottom Plate	8
Point to Point Diagrams	13
Incoming Power	13
Heater Circuit.....	14
24VDC Power Circuit.....	15
Ladder Diagrams	16
Incoming Power	16
Heater Circuit.....	17
24VDC Power Circuit.....	18
380 VAC.....	19
Component Identification	19
Console Assembly	19
Front Panel	20
Bottom Plate	22
Point to Point Diagrams	27
Incoming Power	27
Heater Circuit.....	28
24 VDC Power Circuit.....	29
Ladder Diagrams	30
Incoming Power	30
Heater Circuit.....	31
24 VDC Power Circuit.....	32

WARRANTY

Polyurethane Machinery Corporation (hereinafter "PMC") provides this LIMITED WARRANTY (hereinafter "Warranty") to the original purchaser (hereinafter "Customer") covering this equipment and the original PMC manufactured accessories delivered with the equipment (hereinafter "Product") against defects in material or workmanship of the Product (hereinafter "Defect" or "Defective") for a period of one (1) year from the date of first purchase as shown on the original PMC invoice (hereinafter "Warranty Period").

If during the Warranty Period under normal use, the Product is suspected by Customer to be Defective in material or workmanship, it is Customer's responsibility to contact PMC and return the Product to PMC as directed by PMC, freight prepaid. If PMC determines that the Product is Defective and that such Defect is covered by this Warranty, PMC will credit Customer for the reasonable freight charges incurred by Customer in returning the Defective Product to PMC, and PMC (or its authorized agent) will, at PMC's option, repair or replace the Product, subject to the following:

Original Invoice: The original invoice must be kept as proof of the date of first sale and the Product serial number. The Warranty does not cover any Product if the Original Invoice appears to have been modified or altered, or when the serial number on the Product appears to have been altered or defaced.

Product Maintenance: It is the Customer's responsibility to maintain the Product properly. See your maintenance schedule and owner's manual for details. The Warranty does not cover an improperly maintained Product.

Non-PMC Components and Accessories: Non-PMC manufactured components and accessories that are used in the operation of the Product are not covered by this Warranty. Such components and accessories shall be subject to the warranty offered to the Customer, if any, by the original manufacturer of such component or accessory.

Other Warranty Exclusions: The Warranty does not cover any Product that PMC determines has been damaged or fails to operate properly due to misuse, negligence, abuse, carelessness, neglect, or accident. By way of example only, this includes:

- Normal wear and tear.
- Improper or unauthorized installation, repair, alteration, adjustment or modification of the Product.
- Use of heating devices, pumping equipment, dispensers, or other parts or accessories with the Product that have not been approved or manufactured by PMC.
- Failure to follow the operating instructions and recommendations provided by PMC.
- Cosmetic damage.
- Fire, flood, "acts of God," or other contingencies beyond the control of PMC.

THE WARRANTY DESCRIBED HEREIN IS THE EXCLUSIVE REMEDY FOR THE CUSTOMER AND IS IN LIEU OF ALL OTHER WARRANTIES, EXPRESS, IMPLIED, STATUTORY OR OTHERWISE, AND THE IMPLIED WARRANTIES OF MERCHANTABILITY AND FITNESS FOR A PARTICULAR PURPOSE AND ALL OTHER WARRANTIES ARE HEREBY DISCLAIMED. TO THE FULLEST EXTENT PERMITTED BY LAW, PMC SHALL NOT BE RESPONSIBLE, WHETHER BASED IN CONTRACT, TORT (INCLUDING, WITHOUT LIMITATION, NEGLIGENCE), WARRANTY OR ANY OTHER LEGAL OR EQUITABLE GROUNDS, FOR ANY CONSEQUENTIAL, INDIRECT, INCIDENTAL, LOST PROFITS, SPECIAL, PUNITIVE OR EXEMPLARY DAMAGES, WHETHER TO PERSON OR PROPERTY, ARISING FROM OR RELATING TO THE PRODUCT, EVEN IF PMC HAS BEEN ADVISED OF THE POSSIBILITY OF SUCH LOSSES OR DAMAGES.

Non-Warranty Service by PMC: If PMC determines that the suspected Defect of the Product is not covered by this Warranty, disposition of the Product will be made pursuant to the terms and conditions of PMC's written estimate on a time and materials basis.

Continuing Warranty for Products Repaired or Replaced under Warranty: Following the repair or replacement of a Product covered by this Warranty, such Product will continue to be subject to the original Warranty for the remainder of original Warranty Period or for three (3) months from the repair or replacement date, whichever is longer.

No Rights Implied: Nothing in the sale, lease or rental of any Product by PMC shall be construed to grant any right, interest or license in or under any patent, trademark, copyright, trade secret or other proprietary right or material owned by anyone; nor does PMC encourage the infringement of same.

Exclusive Warranty: This writing is the final, complete, and exclusive expression of the Warranty covering the Product. Any statements made by PMC, its employees or agents that differ from the terms of this Warranty shall have no effect. It is expressly understood that Customer's acceptance of this Warranty, by performance or otherwise, is upon and subject solely to the terms and conditions hereof, and any additional or different terms and conditions proposed or expressed by Customer or anyone, whether in writing or otherwise, are null and void unless specifically agreed to in writing by an Officer of PMC.

SAFETY AND HANDLING

This chapter contains important information on the safety, handling and use of your PH Series Console.



Before performing maintenance and starting up the PH Series Console, carefully read and comprehend all the technical and safety information included in this manual. The information is aimed at enhancing user safety and avoiding possible breakdowns caused by incorrect or improper use.

Always disconnect the console from the main power source before opening the console.

WARNING! Presents information to alert of a situation that might cause serious injuries if the instructions are not followed.

CAUTION Presents information that indicates how to avoid damage to the Proportioner or how to avoid a situation that could cause minor injuries.

NOTE! Is relevant information of a procedure being carried out.

Careful study of this manual will enable the operator to understand the characteristics of the PH Series Console and the operating procedures. By following the instructions and recommendations contained herein, you will reduce the potential risk of accidents in the installation, use, or maintenance of the PH Series Console. You will also provide a better opportunity for increased output, incident-free operation for a longer time, and the possibility of detecting and resolving problems fast and simply.

Keep this Operations Manual for future consultation of useful information at all times. If you lose this manual, ask for a new copy from your PMC authorized distributor or go online at our web site (www.polymac-usa.com).



To prevent possible injury caused by incorrect handling of the raw materials and solvents used in the process, carefully read the Material Safety Data Sheet (MSDS) provided by your supplier.

Deal with waste caused according to current regulations.

Pour éviter toute blessure causée par une mauvaise manipulation des matières premières et les solvants utilisés dans le processus, veuillez lire attentivement la fiche signalétique (MSDS) fournies par votre fournisseur.



To avoid damage caused by the impact of pressurized fluids, do not open any connection or perform maintenance work on the components subject to pressure until the pressure has been completely eliminated.

Pour éviter les dommages causés par l'impact des fluides sous pression, ne pas ouvrir un lien ou d'effectuer des travaux d'entretien sur les éléments soumis à la pression jusqu'à ce que la pression a été complètement éliminé.



Use suitable protection when operating, maintaining or being present in the area where the equipment is functioning. This includes, but is not limited to, the use of protective goggles, gloves, shoes and safety clothing and breathing equipment.



Utiliser une protection appropriée utilisation, d'entretien ou d'être présents dans la région où le matériel fonctionne. Cela inclut, mais n'est pas limité à, l'utilisation de lunettes de protection, gants, chaussures et vêtements de sécurité et un équipement respiratoire.



The equipment includes components that reach high temperatures and can cause burns. Hot parts of the equipment must NOT be handled or touched until they have cooled completely.

L'équipement comprend des éléments qui atteignent des températures élevées et peuvent provoquer des brûlures. Les parties chaudes de l'équipement ne doit pas être manipulé ou touché jusqu'à ce qu'ils aient complètement refroidi.



To prevent serious injury through crushing or amputation, do not work with the equipment without the safety guards installed on the moving parts. Make sure that all the safety guards are correctly reinstalled at the end of the repair or maintenance work of the equipment.

L'équipement comprend des éléments qui atteignent des températures élevées et peuvent provoquer des brûlures. Les parties chaudes de l'équipement ne doit pas être manipulé ou touché jusqu'à ce qu'ils aient complètement refroidi.



220 VAC

Component Identification

Console Assembly

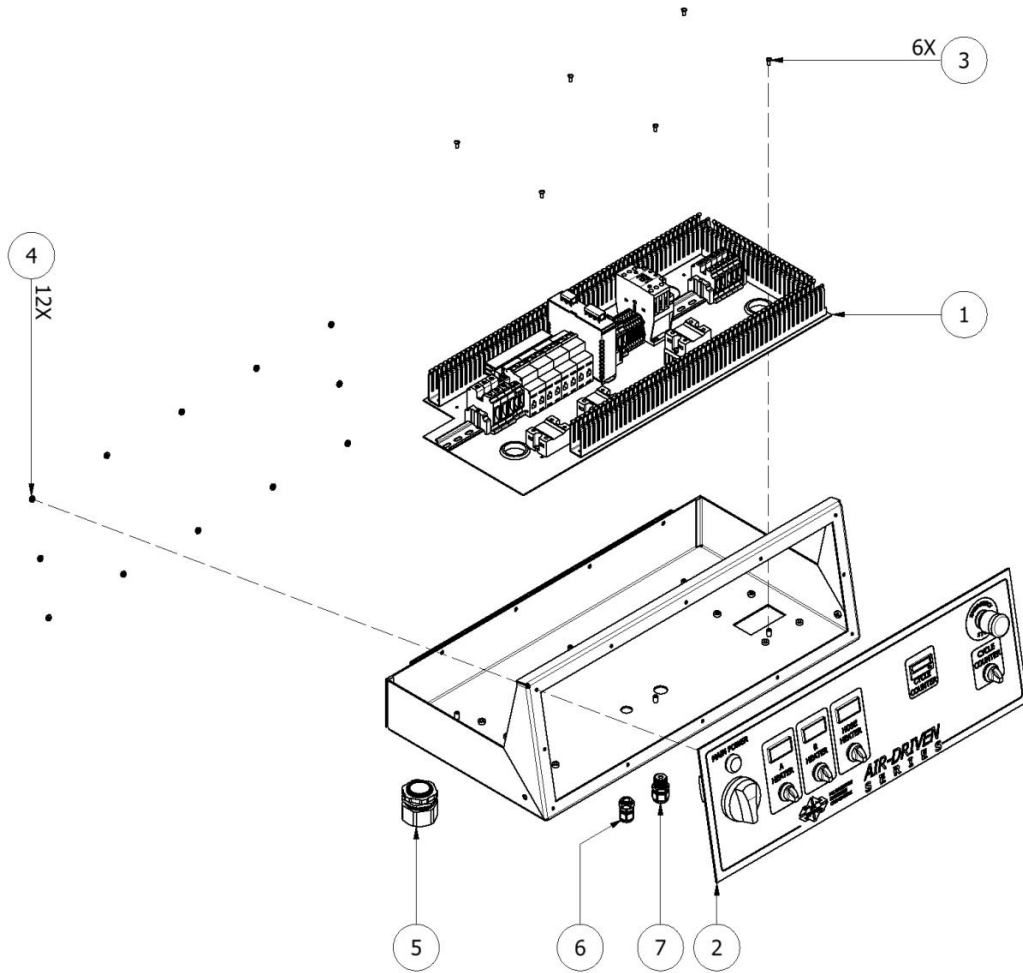

CONSOLE ASSEMBLY			
ITEM	QTY	PART NUMBER	DESCRIPTION
1	1	-	BOTTOM PLATE (SEE PAGE 8)
2	1	-	FRONT PANEL (SEE PAGE 6)
3	6	-	#8-32 X 3/8 CROSS RECESSED PAN HEAD
4	12	-	#8-32 SERRATED WASHER
5	1	EL-00088-01A	HEYCO SR INCOMING POWER
6	1	EL-000P12	HEYCO #6 AWG STRAIN RELIEF
7	1	EL-000P13	STRAIN RELIEF

Front Panel

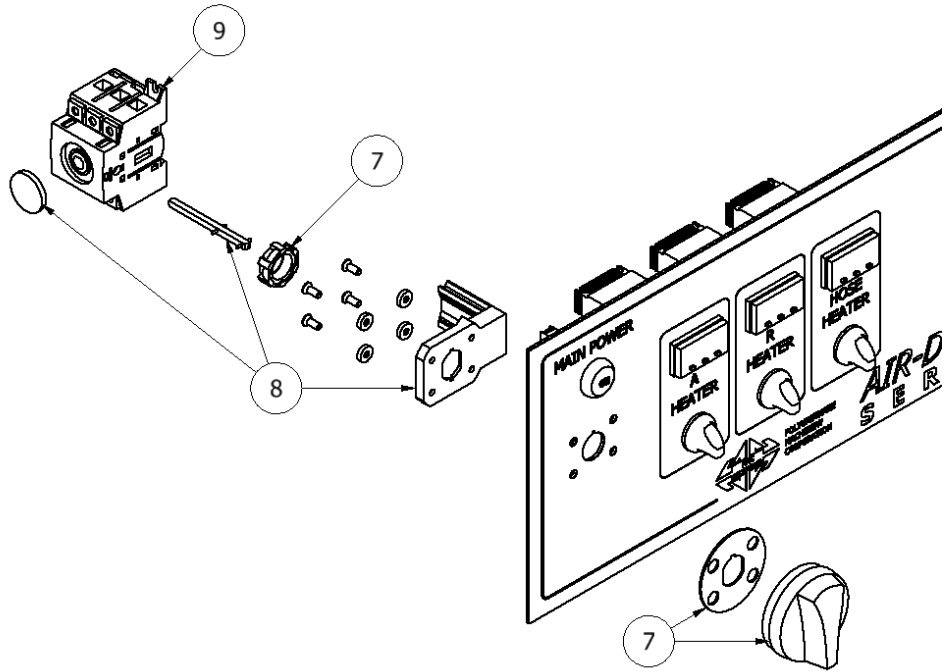
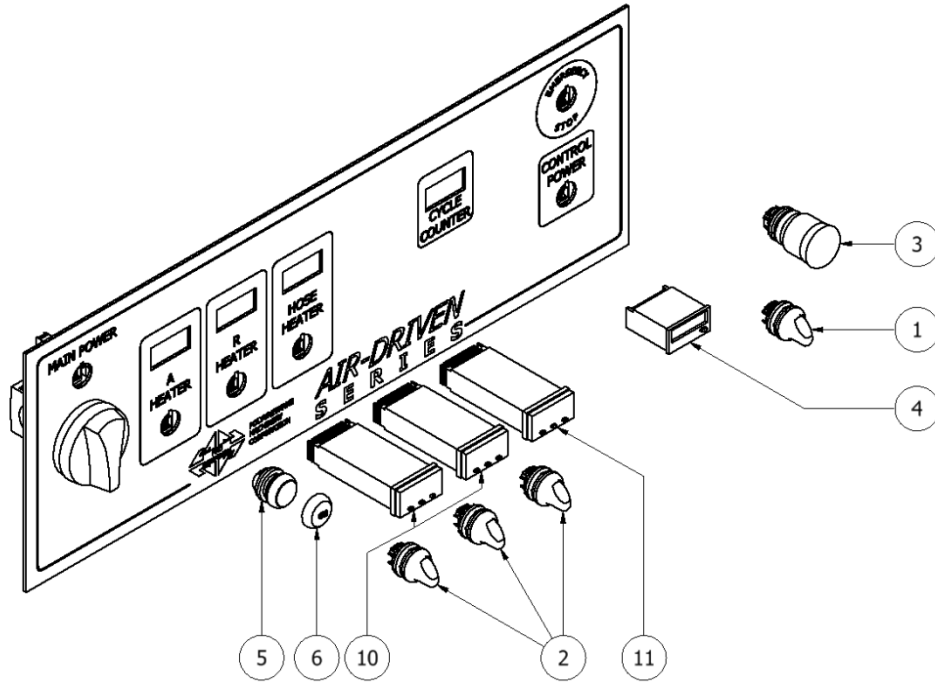

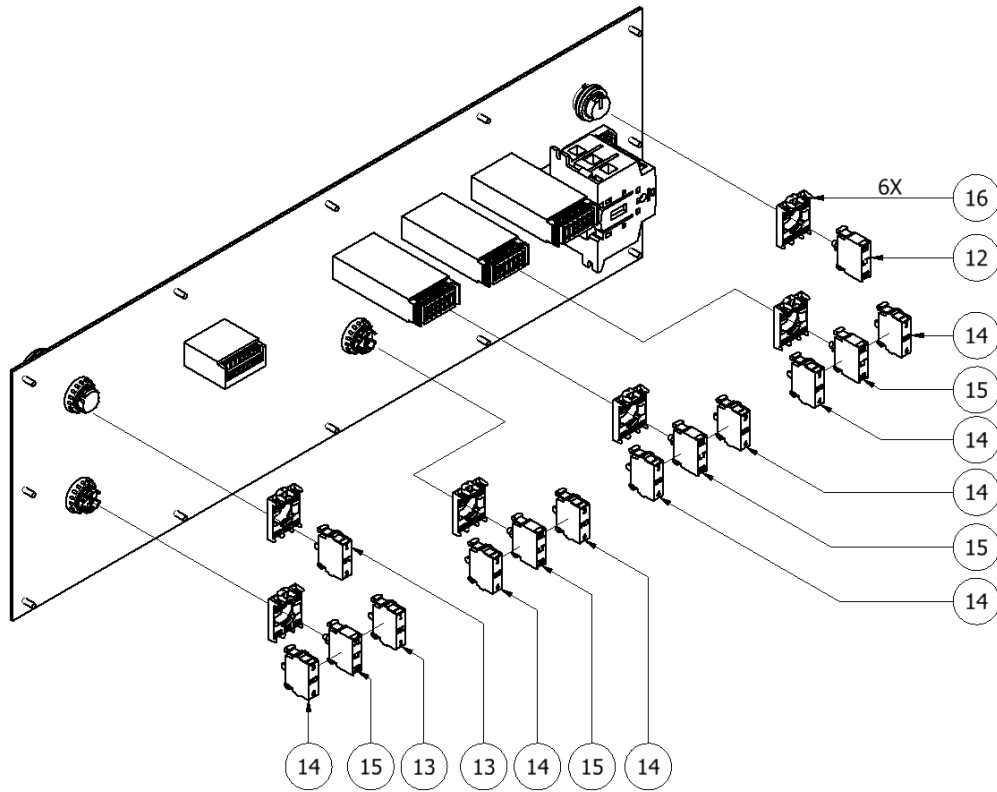

FRONT PANEL COMPONENTS			
ITEM	QTY	PART NUMBER	DESCRIPTION
1	1	EL-128-R	SELECTOR SWITCH; 3 POS; RED
2	3	EL-129-R	SELECTOR SWITCH; RED
3	1	EL-107	E-STOP PUSH-TWIST
4	1	EL-124	TOTALIZER; BATT OP
5	1	EL-134	LIGHT SWITCH
6	1	EL-135	GREEN LENS; "ON"
7	1	EL-105	SELECTOR HANDLE; RED
8	1	EL-103	DOOR MOUNTING KIT
9	1	EL-100	ROTARY DISCONNECT; 80A; 3 POLE
10	2	EL-159-HTR	TEMPERATURE CONTROLLER; PRE-HTR
11	1	EL-159-H	TEMPERATURE CONTROLLER; HOSE
12	1	EL-132-G	GREEN LIGHT UNIT
13	2	EL-133-NC	CONTACT BLOCK; NC
14	7	EL-133-NO	CONTACT BLOCK; NO
15	4	EL-131-R	LIGHT UNIT; RED; 24VDC
16	6	-	MOUNTING ADAPTER

Bottom Plate

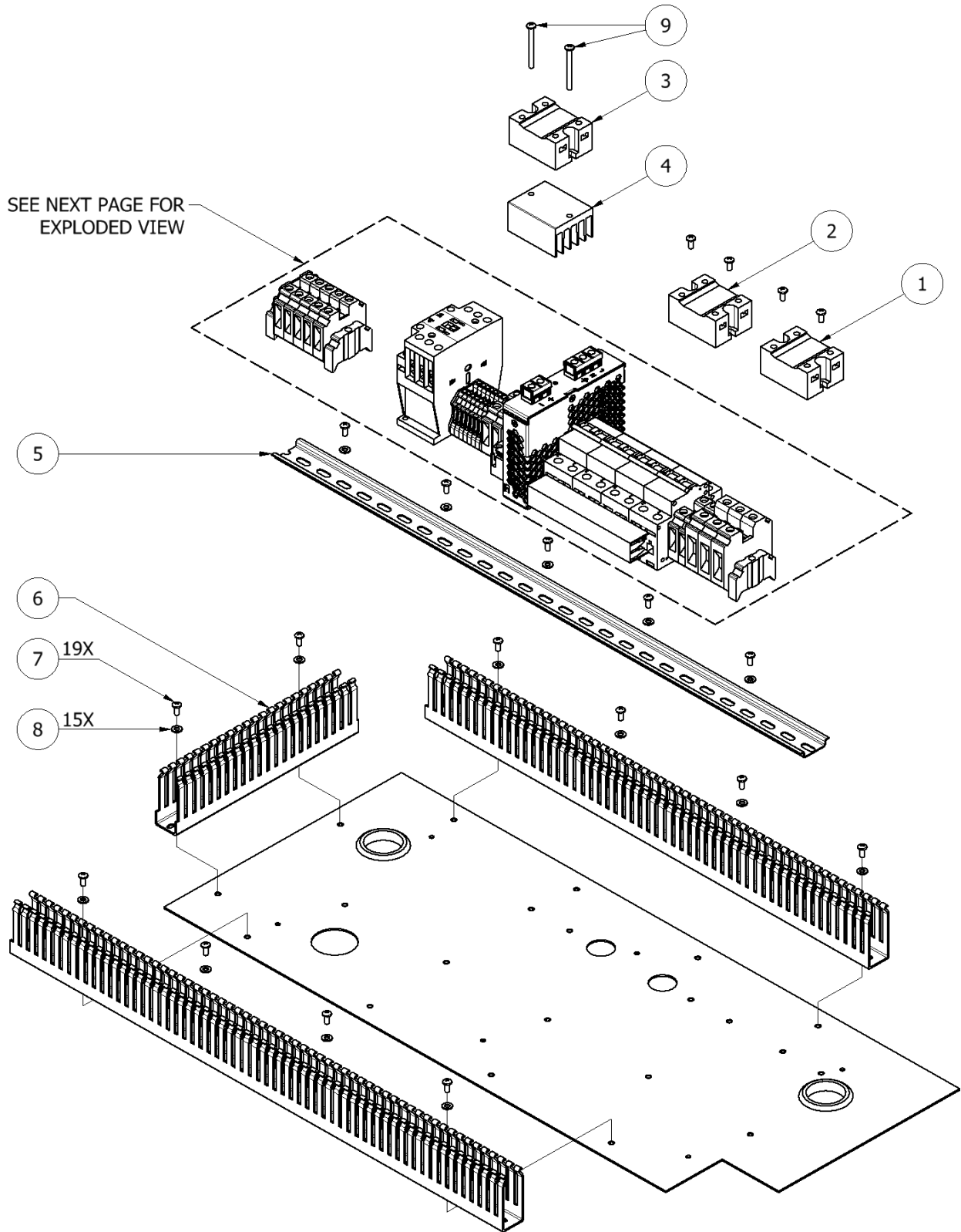

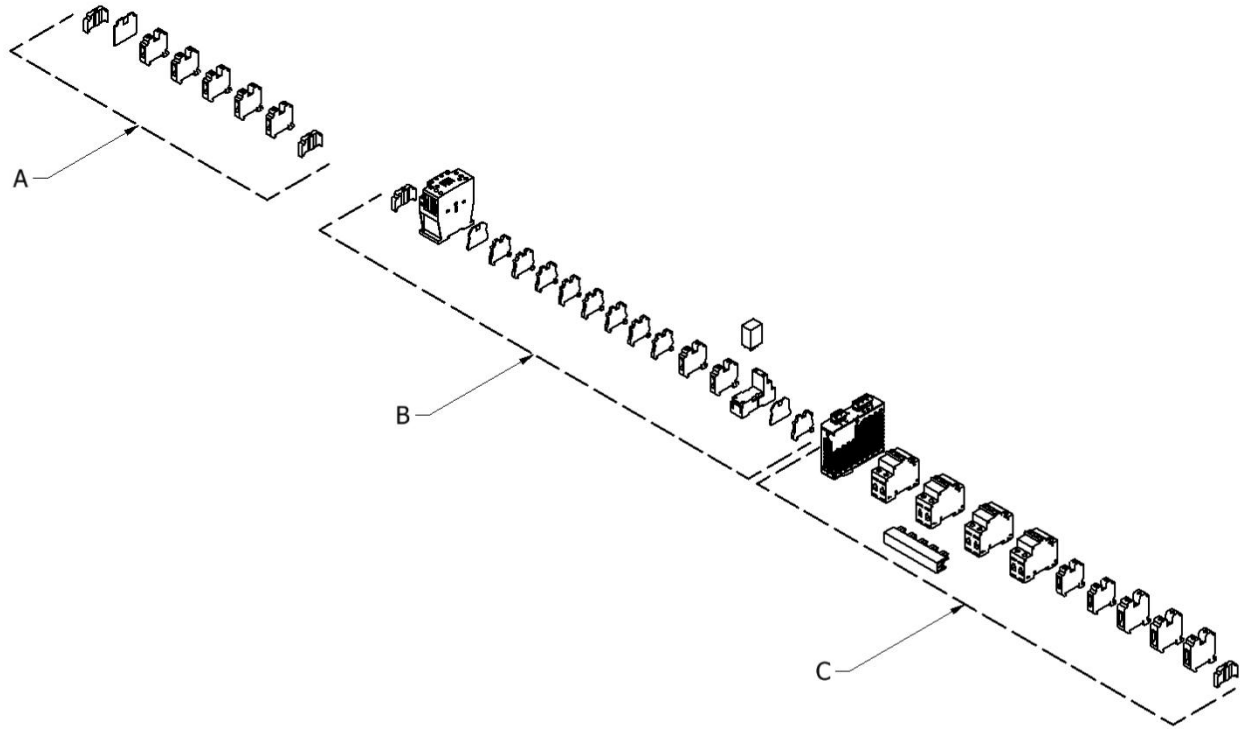

BOTTOM PLATE COMPONENTS				
ITEM	QTY	PART NUMBER	DESCRIPTION	LABEL
1	1	EL-34	RELAY; 50 AMP; 480V	SSR1 A-HTR
2	1	EL-34	RELAY; 50 AMP; 480V	SSR2 R-HTR
3	1	EL-35	RELAY; HOSE HEAT	SSR3 HOSE
4	1	EL-35-1	HEAT SINK	-
5	2	EL-147	DIN RAIL; 35 X 7.5 MM	-
6	5	EL-149	WIRE DUCT 1.0 X 2.25	-
7	19	-	CROSS RECESSED PAN HEAD #8-32 X 3/8	-
8	15	-	#8 PLAIN WASHER	-
9	2	-	CROSS RECESSED PAN HEAD #8-32 X 1-3/4	-
A	1	-	SEE PAGE 10	-
B	1	-	SEE PAGE 11	-
C	1	-	SEE PAGE 12	-

Detail A

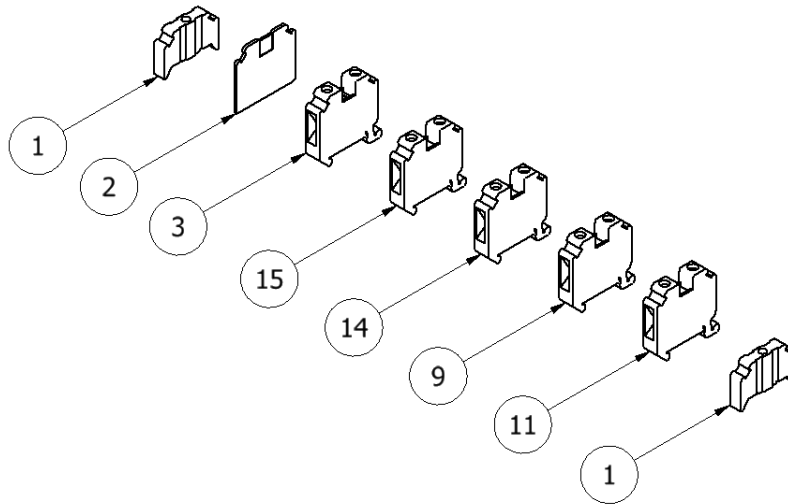

BOTTOM PLATE COMPONENTS				
ITEM	QTY	PART NUMBER	DESCRIPTION	LABEL
1	2	EL-152	END STOP; 35MM	-
2	1	EL-156	END COVERS; 12MM TERM BLOCKS	-
3	1	EL-145	12MM GROUND BLOCK 15-4 AWG	GRD
9	1	EL-141	TERMINAL BLOCK; 10.2MM	9
11	1	EL-141	TERMINAL BLOCK; 10.2MM	11
14	1	EL-141	TERMINAL BLOCK; 10.2MM	14
15	1	EL-141	TERMINAL BLOCK; 10.2MM	15

Detail B

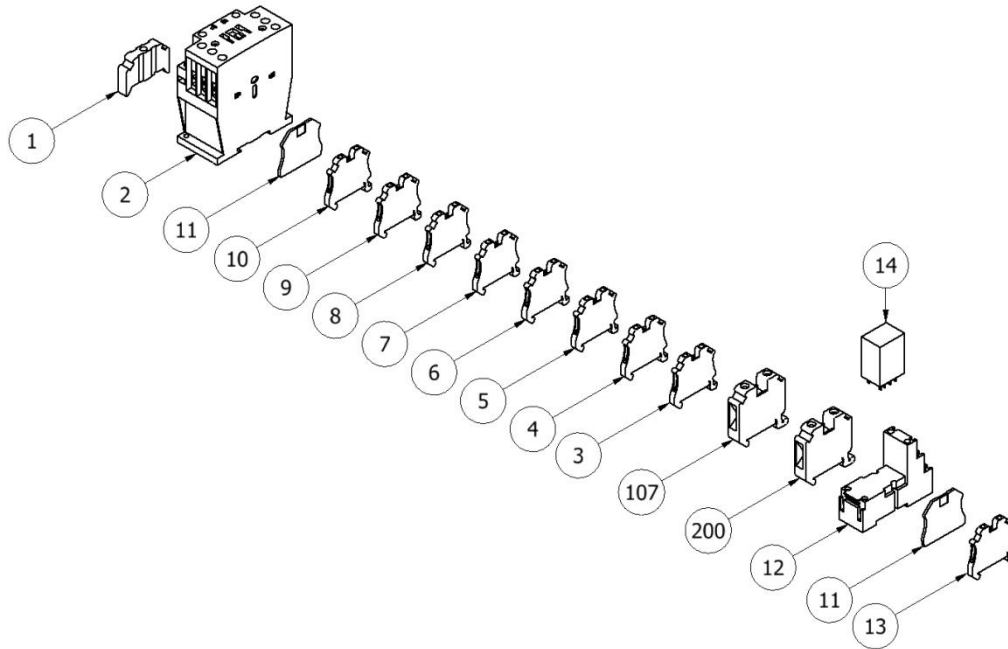

BOTTOM PLATE COMPONENTS				
ITEM	QTY	PART NUMBER	DESCRIPTION	LABEL
1	1	EL-152	END STOP; 35MM	-
2	1	EL-118	CONTACTOR; 32A; 24VDC COIL	M1
3	1	EL-140	TERMINAL BLOCK; 5.2MM	3
4	1	EL-140	TERMINAL BLOCK; 5.2MM	4
5	1	EL-140	TERMINAL BLOCK; 5.2MM	5
6	1	EL-140	TERMINAL BLOCK; 5.2MM	6
7	1	EL-140	TERMINAL BLOCK; 5.2MM	7
8	1	EL-140	TERMINAL BLOCK; 5.2MM	8
9	1	EL-140	TERMINAL BLOCK; 5.2MM	9
10	1	EL-140	TERMINAL BLOCK; 5.2MM	10
11	2	EL-156-10	TERMINAL COVER; 10MM/5.2MM	-
12	1	EL-121	RELAY SOCKET	-
13	1	EL-144	TERMINAL BLOCK; 5.2MM; GRND	GRD
14	1	EL-120	DPDT RELAY; 24VDC COIL	MCR
107	1	EL-142	TERMINAL BLOCK; 12MM	107
200	1	EL-142	TERMINAL BLOCK; 12MM	200

Detail C

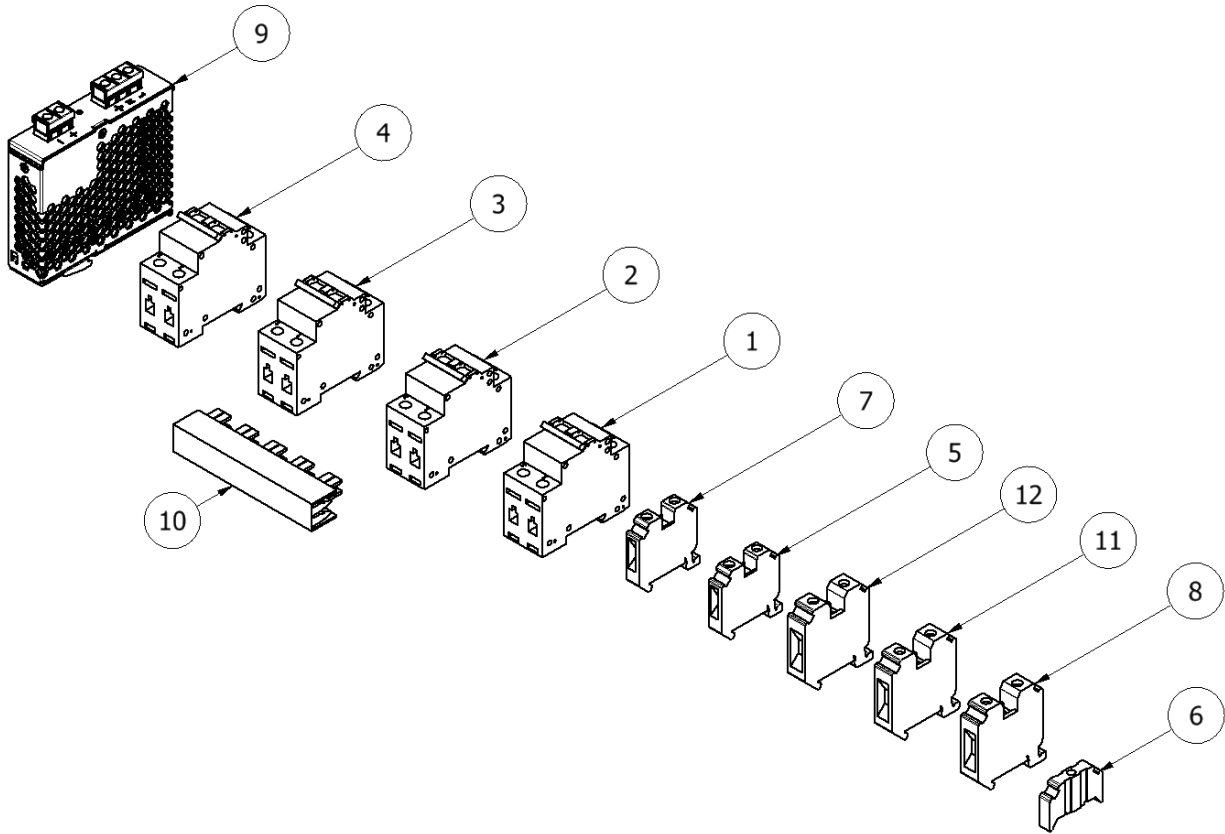

BOTTOM PLATE COMPONENTS				
ITEM	QTY	PART NUMBER	DESCRIPTION	LABEL
1	1	EL-116	CIRCUIT BREAKER; 25A, 2 POLE; TYPE UL1077	CB1 A-HTR
2	1	EL-116	CIRCUIT BREAKER; 25A, 2 POLE TYPE UL1077	CB1 R-HTR
3	1	EL-115	CIRCUIT BREAKER; 15A, 2 POLE TYPE UL1077	CB3 HOSE
4	1	EL-114	CIRCUIT BREAKER; 3A, 2 POLE TYPE UL1077	CB4 CNTL
5	1	EL-142	TERMINAL BLOCK; 12MM	5
6	1	EL-152	END STOP; 35MM	-
7	1	EL-142	TERMINAL BLOCK; 12MM	7
8	1	EL-146	TERMINAL BLOCK; 16MM; GRND	GRD
9	1	EL-122	POWER SUPPLY; 2.5A; 230VAC/24VDC	PS
10	1	EL-151	JUMPER STRIP	-
11	1	EL-143	TERMINAL BLOCK; 16MM	L1
12	1	EL-143	TERMINAL BLOCK; 16MM	L2

Point to Point Diagrams

Incoming Power

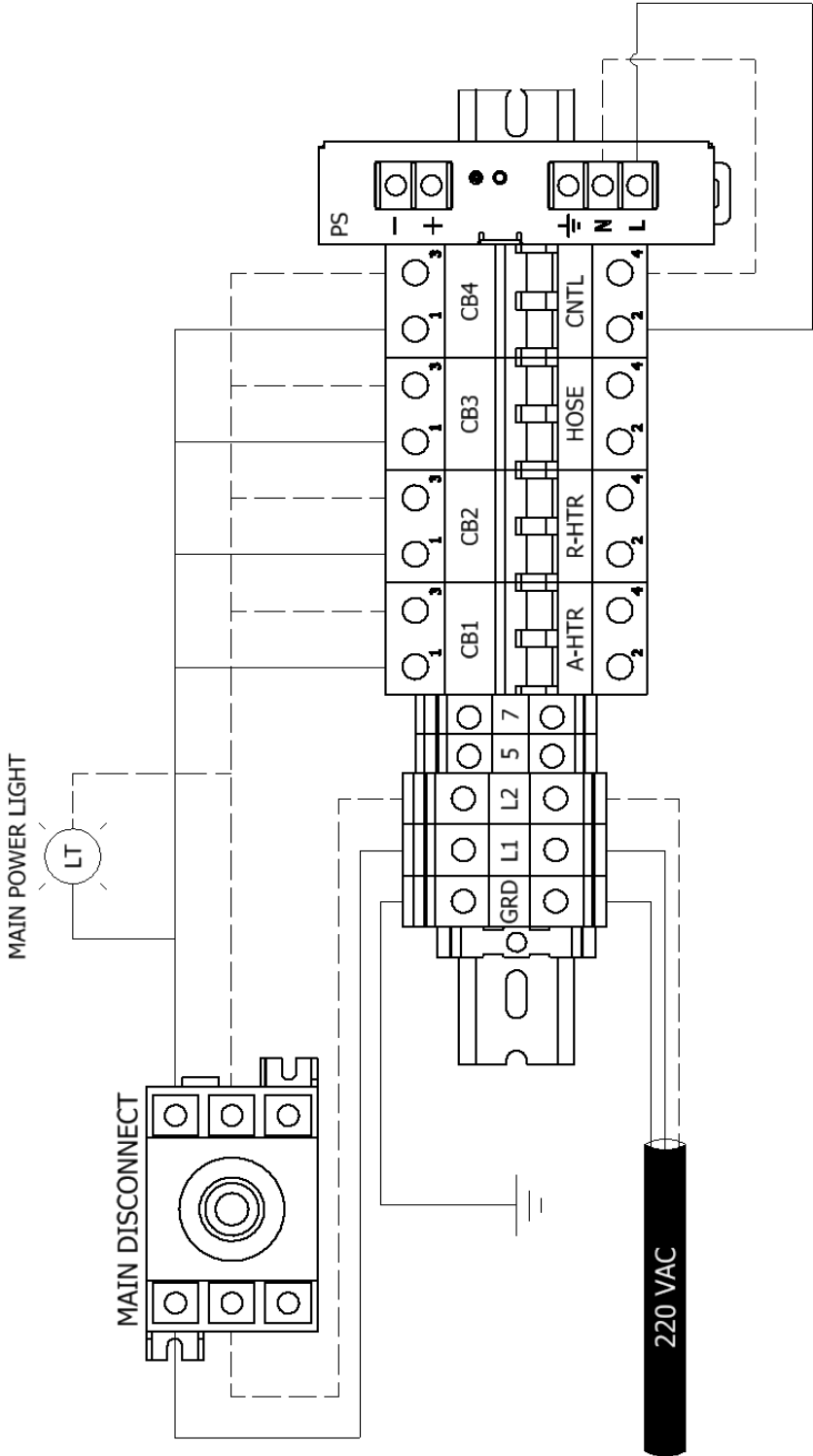

Heater Circuit

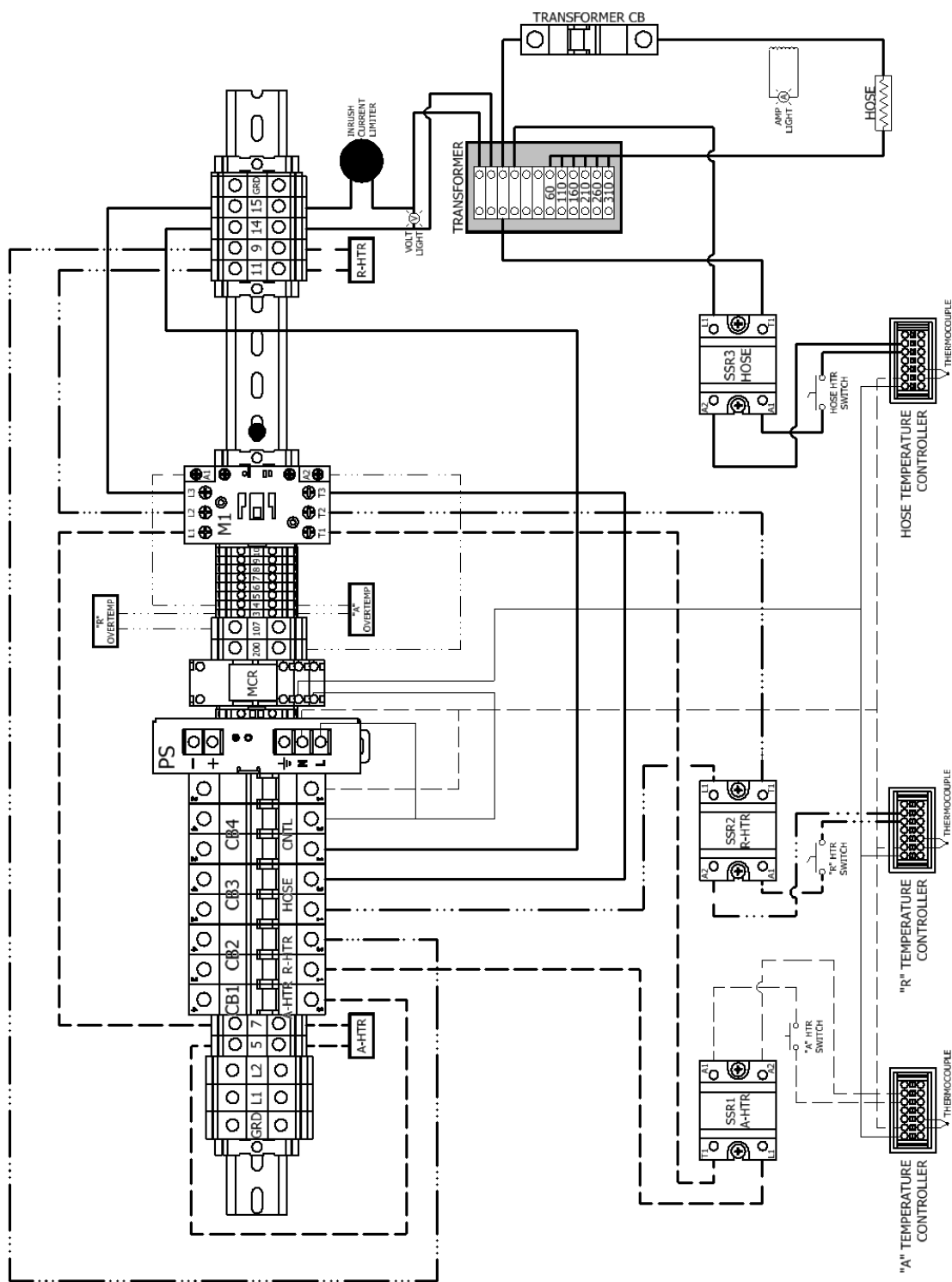

24VDC Power Circuit

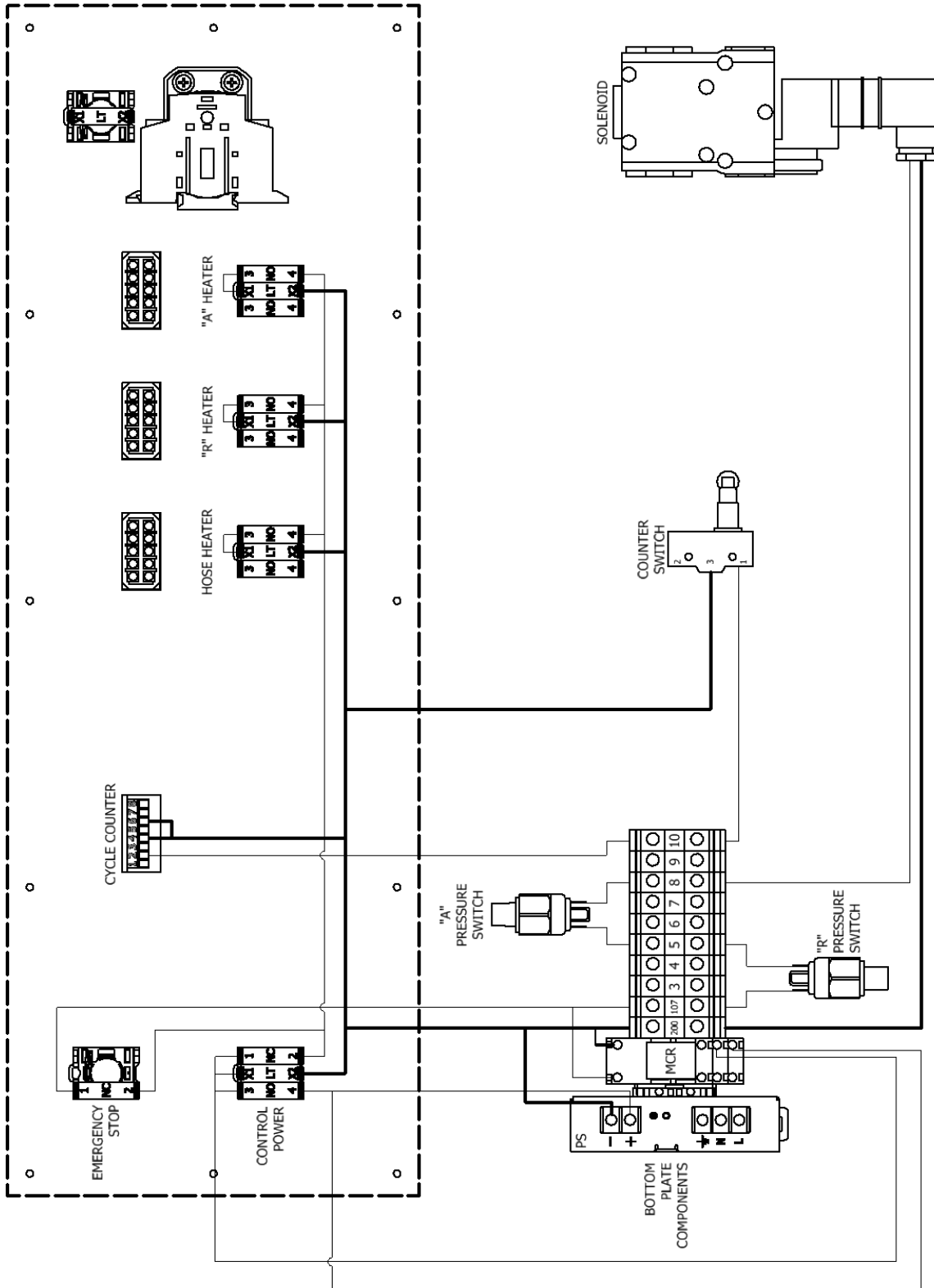

Ladder Diagrams

Incoming Power

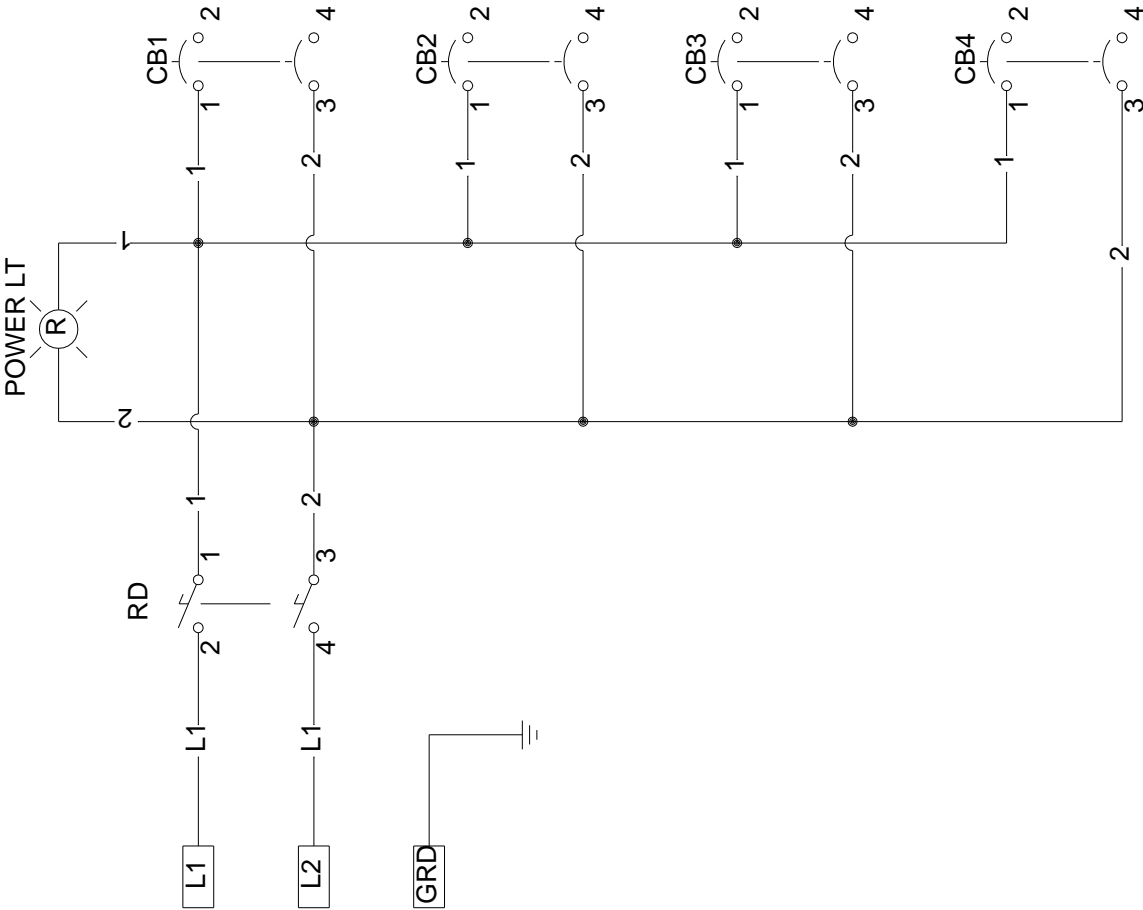

Heater Circuit

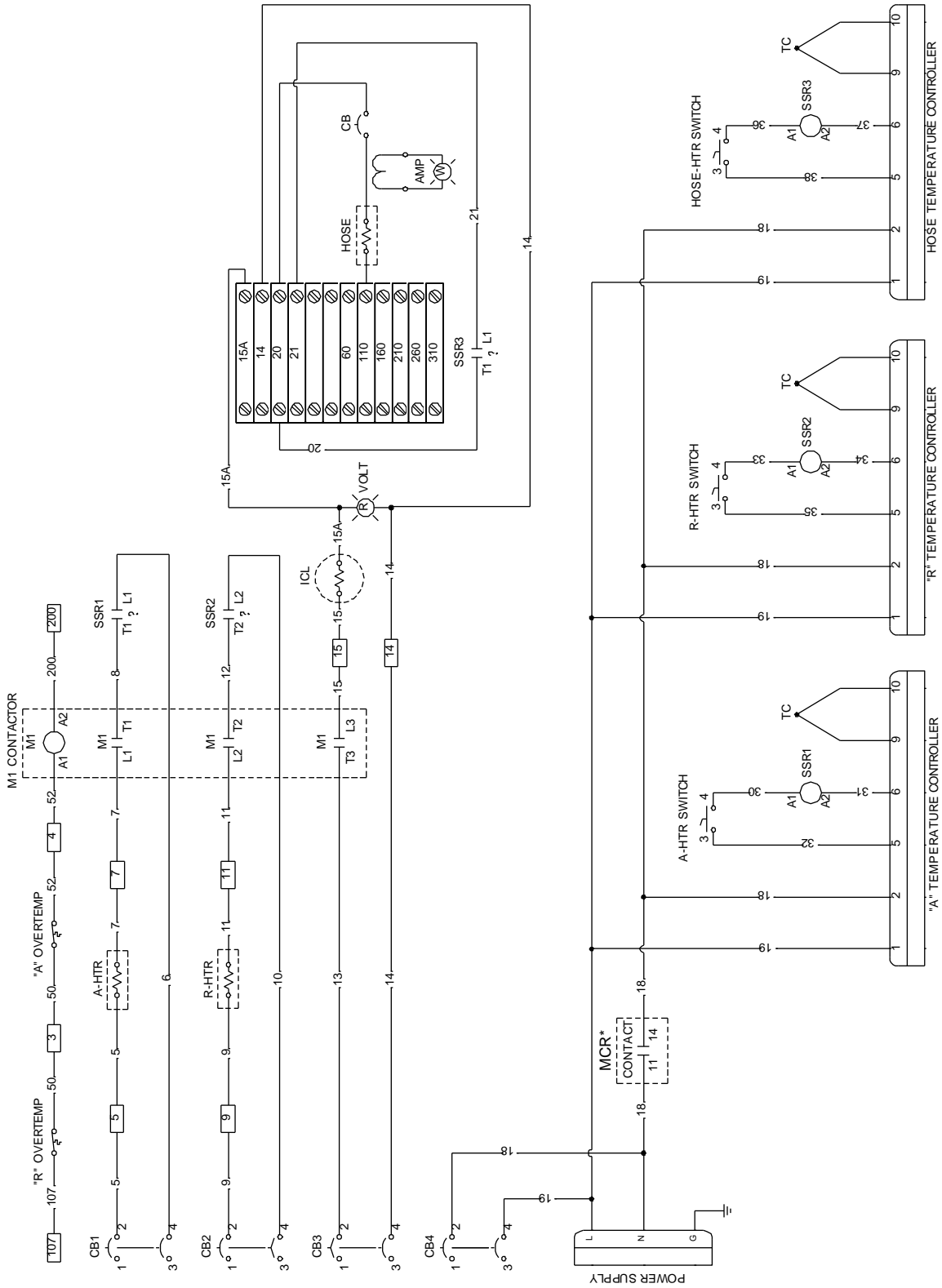

*See 24 VDC Power Circuit on page 18 for complete MCR wiring

24VDC Power Circuit

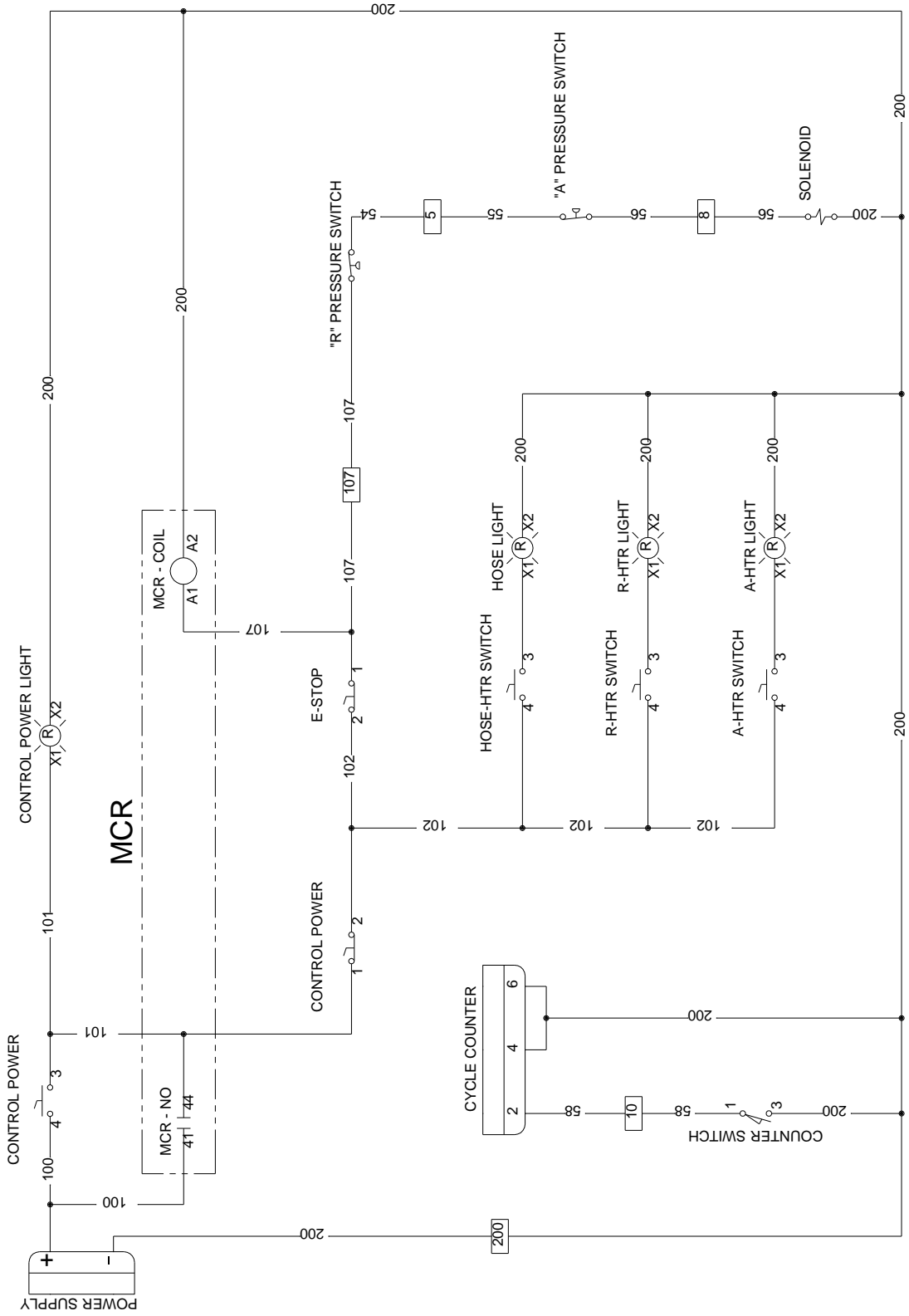

380 VAC

Component Identification

Console Assembly

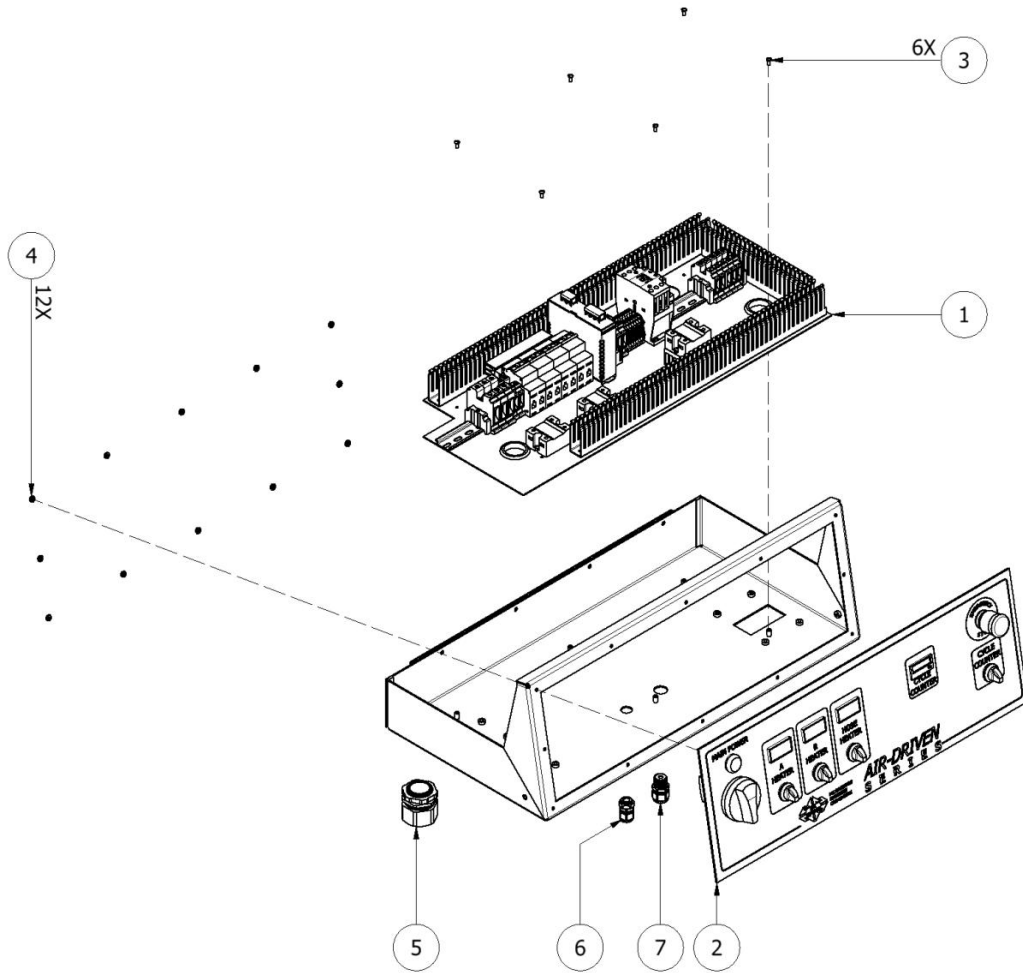

CONSOLE ASSEMBLY			
ITEM	QTY	PART NUMBER	DESCRIPTION
1	1	-	BOTTOM PLATE (SEE PAGE 22)
2	1	-	FRONT PANEL (SEE PAGE 20)
3	6	-	#8-32 X 3/8 CROSS RECESSED PAN HEAD
4	12	-	#8-32 SERRATED WASHER
5	1	EL-00088-01A	HEYCO SR INCOMING POWER
6	1	EL-000P12	HEYCO #6 AWG STRAIN RELIEF
7	1	EL-000P13	STRAIN RELIEF

Front Panel

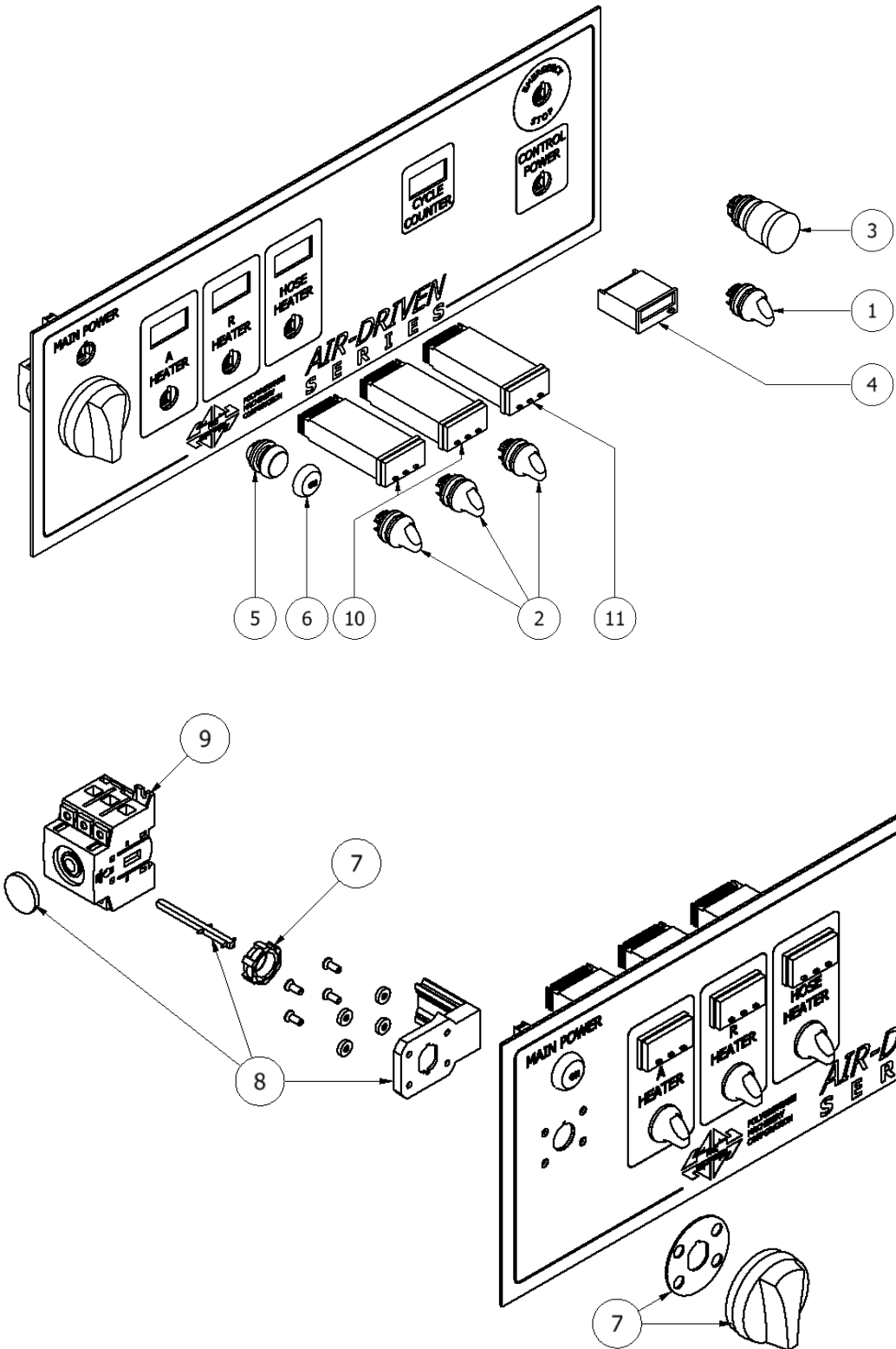

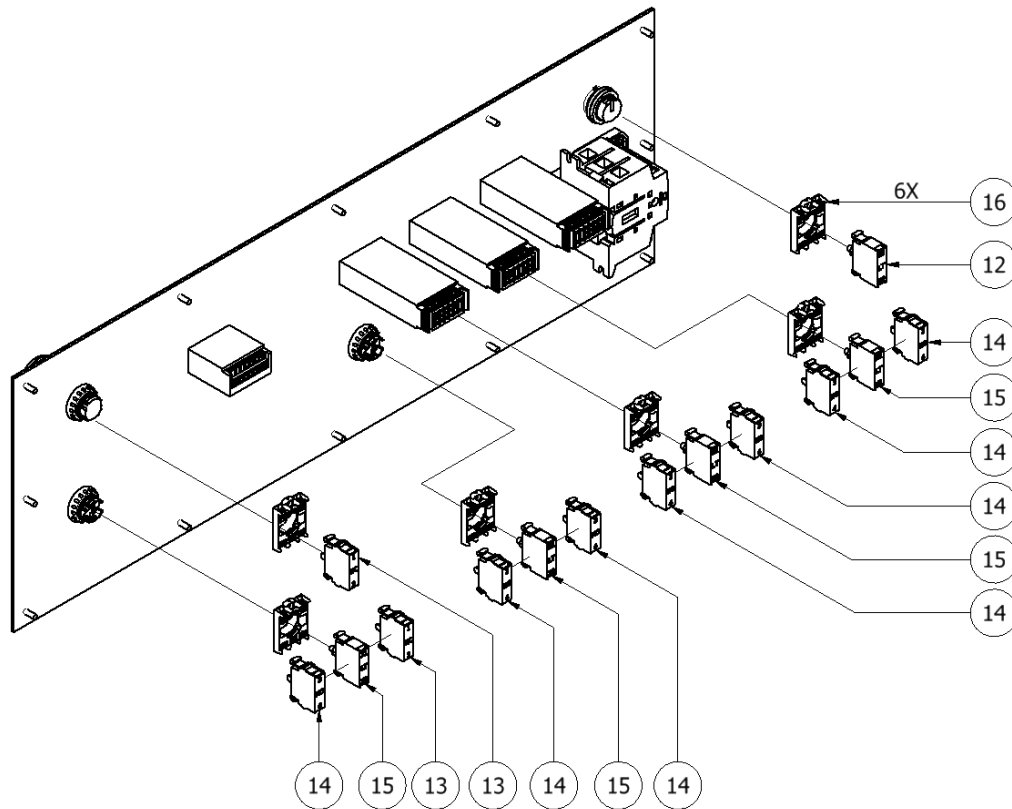

FRONT PANEL COMPONENTS			
ITEM	QTY	PART NUMBER	DESCRIPTION
1	1	EL-128-R	SELECTOR SWITCH; 3 POS; RED
2	3	EL-129-R	SELECTOR SWITCH; RED
3	1	EL-107	E-STOP PUSH-TWIST
4	1	EL-124	TOTALIZER; BATT OP
5	1	EL-134	LIGHT SWITCH
6	1	EL-135	GREEN LENS; "ON"
7	1	EL-105	SELECTOR HANDLE; RED
8	1	EL-103	DOOR MOUNTING KIT
9	1	EL-100	ROTARY DISCONNECT; 80A; 3 POLE
10	2	EL-159-HTR	TEMPERATURE CONTROLLER; PRE-HTR
11	1	EL-159-H	TEMPERATURE CONTROLLER; HOSE
12	1	EL-132-G	GREEN LIGHT UNIT
13	2	EL-133-NC	CONTACT BLOCK; NC
14	7	EL-133-NO	CONTACT BLOCK; NO
15	4	EL-131-R	LIGHT UNIT; RED; 24VDC
16	6	-	MOUNTING ADAPTER

Bottom Plate

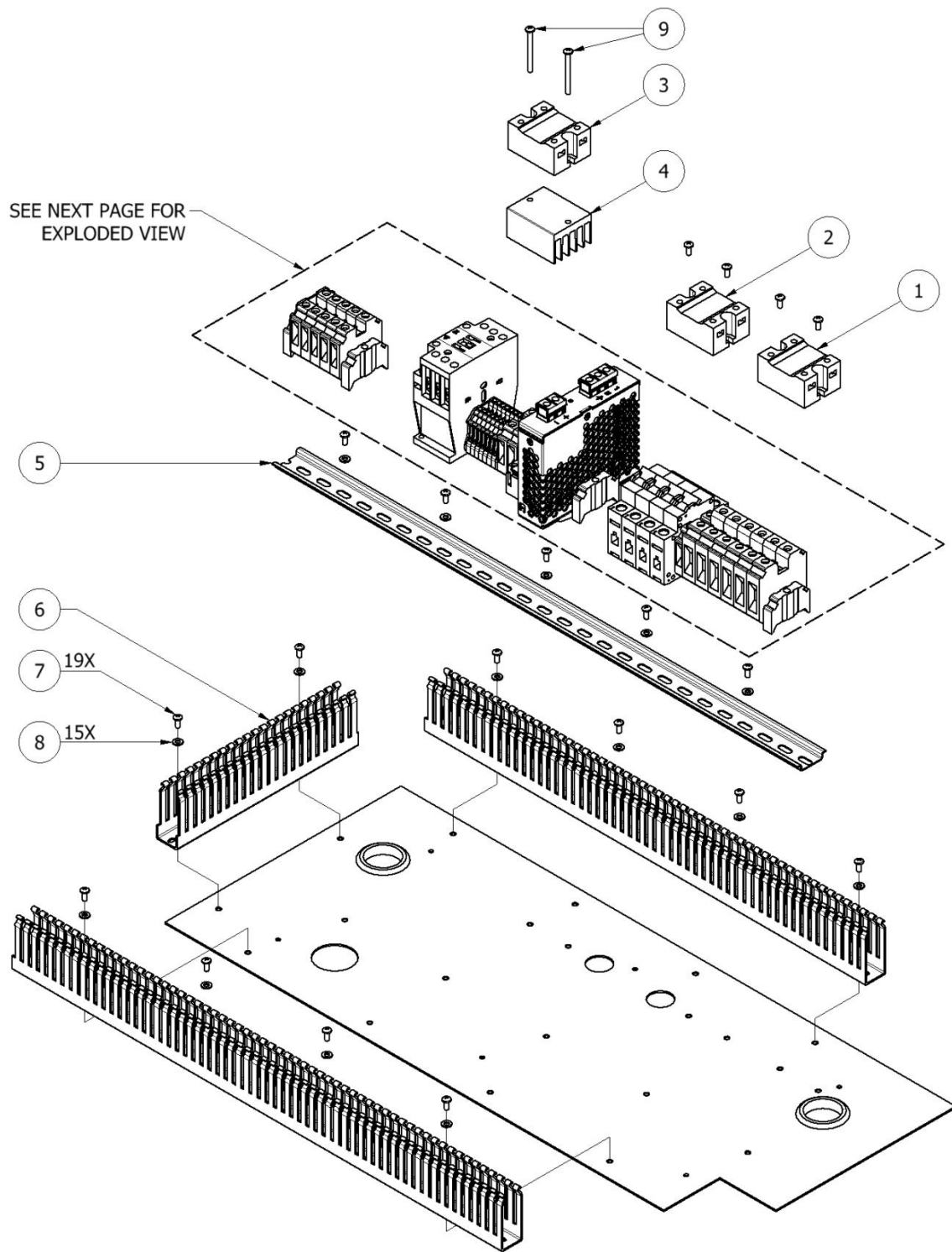

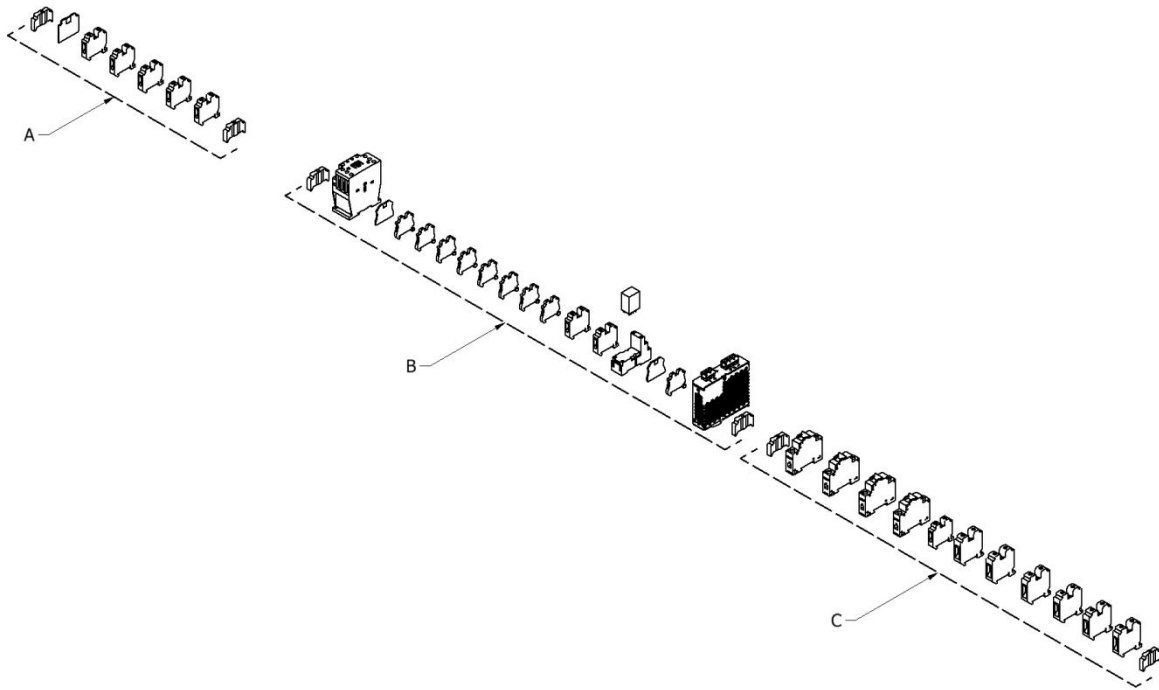

BOTTOM PLATE COMPONENTS				
ITEM	QTY	PART NUMBER	DESCRIPTION	LABEL
1	1	EL-34	RELAY; 50 AMP; 480V	SSR1 A-HTR
2	1	EL-34	RELAY; 50 AMP; 480V	SSR2 R-HTR
3	1	EL-35	RELAY; HOSE HEAT	SSR3 HOSE
4	1	EL-35-1	HEAT SINK	-
5	2	EL-147	DIN RAIL; 35 X 7.5 MM	-
6	5	EL-149	WIRE DUCT 1.0 X 2.25	-
7	19	-	CROSS RECESSED PAN HEAD #8-32 X 3/8	-
8	15	-	#8 PLAIN WASHER	-
9	2	-	CROSS RECESSED PAN HEAD #8-32 X 1-3/4	-
A	1	-	SEE PAGE 24	-
B	1	-	SEE PAGE 25	-
C	1	-	SEE PAGE 26	-

Detail A

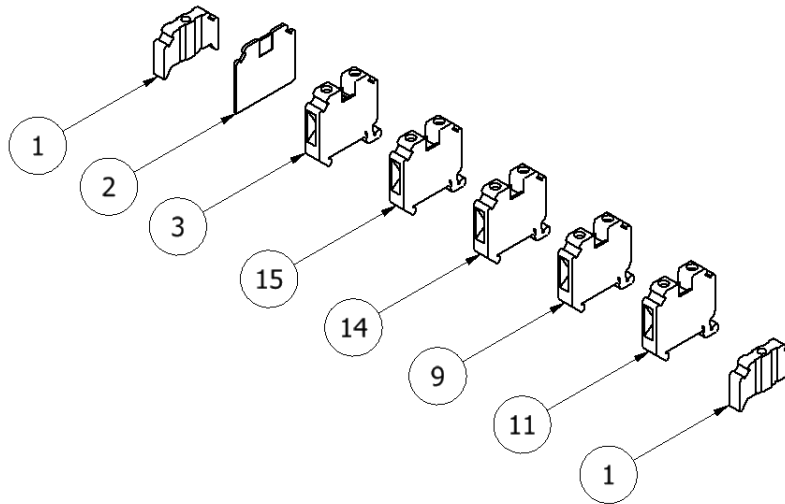

BOTTOM PLATE COMPONENTS				
ITEM	QTY	PART NUMBER	DESCRIPTION	LABEL
1	2	EL-152	END STOP; 35MM	-
2	1	EL-156	END COVERS; 12MM TERM BLOCKS	-
3	1	EL-145	12MM GROUND BLOCK 15-4 AWG	GRD
9	1	EL-141	TERMINAL BLOCK; 10.2MM	N
11	1	EL-141	TERMINAL BLOCK; 10.2MM	11
14	1	EL-141	TERMINAL BLOCK; 10.2MM	N
15	1	EL-141	TERMINAL BLOCK; 10.2MM	15

Detail B

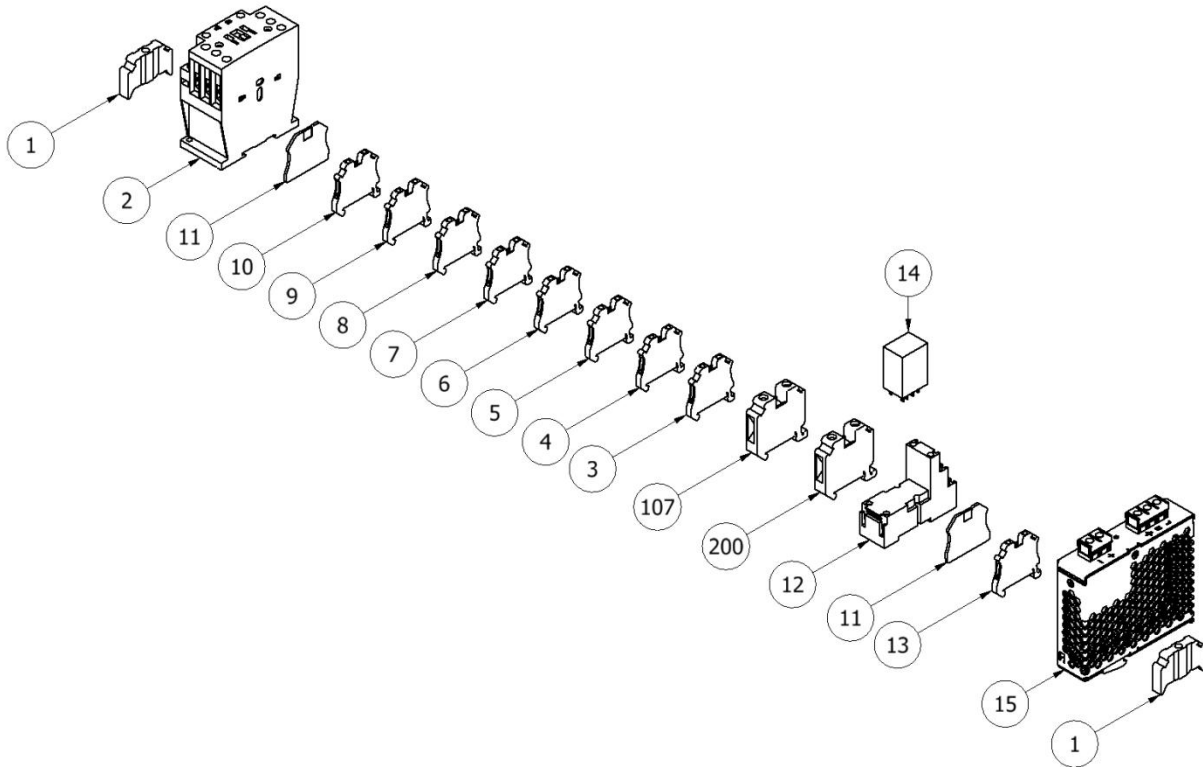

BOTTOM PLATE COMPONENTS				
ITEM	QTY	PART NUMBER	DESCRIPTION	LABEL
1	2	EL-152	END STOP; 35MM	-
2	1	EL-118	CONTACTOR; 32A; 24VDC COIL	M1
3	1	EL-140	TERMINAL BLOCK; 5.2MM	3
4	1	EL-140	TERMINAL BLOCK; 5.2MM	4
5	1	EL-140	TERMINAL BLOCK; 5.2MM	5
6	1	EL-140	TERMINAL BLOCK; 5.2MM	6
7	1	EL-140	TERMINAL BLOCK; 5.2MM	7
8	1	EL-140	TERMINAL BLOCK; 5.2MM	8
9	1	EL-140	TERMINAL BLOCK; 5.2MM	9
10	1	EL-140	TERMINAL BLOCK; 5.2MM	10
11	2	EL-156-10	TERMINAL COVER; 10MM/5.2MM	-
12	1	EL-121	RELAY SOCKET	-
13	1	EL-144	TERMINAL BLOCK; 5.2MM; GRND	GRD
14	1	EL-120	DPDT RELAY; 24VDC COIL	MCR
15	1	EL-122	POWER SUPPLY; 2.5A; 230VAC/24VDC	PS
107	1	EL-142	TERMINAL BLOCK; 12MM	107
200	1	EL-142	TERMINAL BLOCK; 12MM	200

Detail C

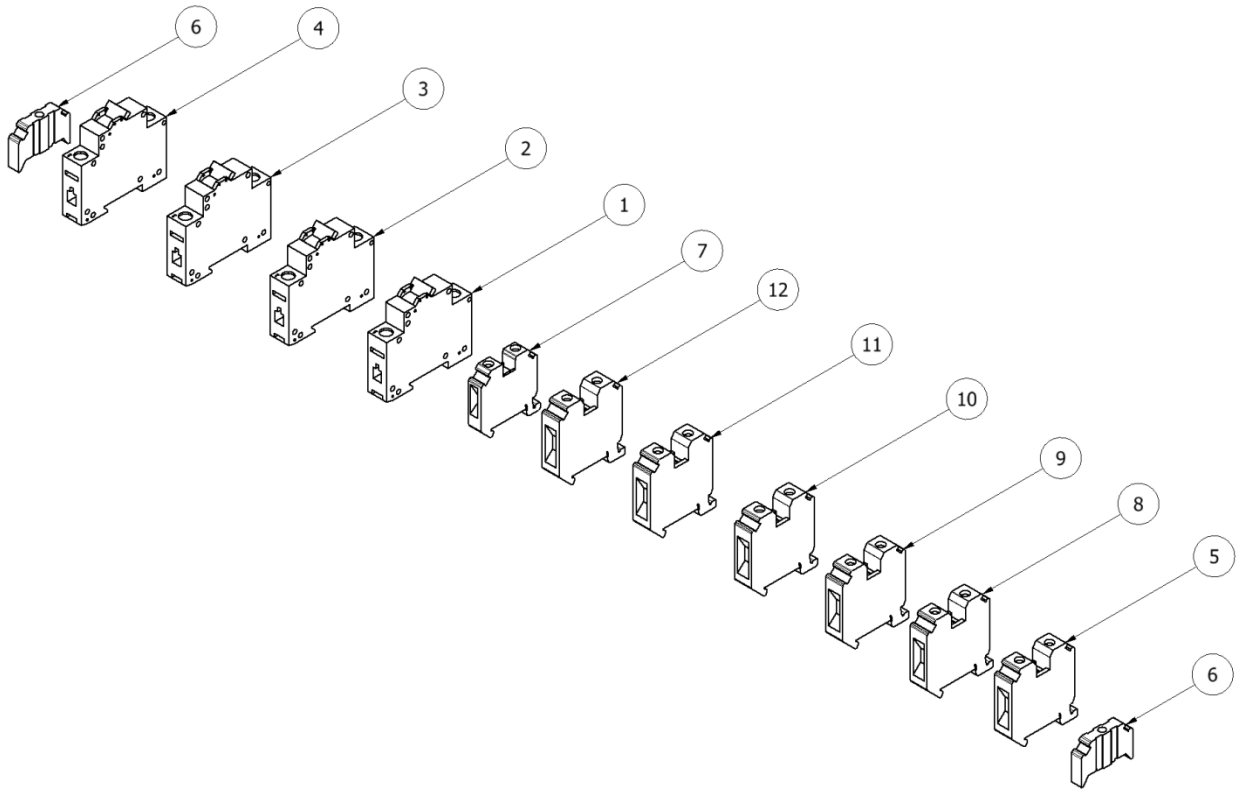

BOTTOM PLATE COMPONENTS				
ITEM	QTY	PART NUMBER	DESCRIPTION	LABEL
1	1	EL-191	CIRCUIT BREAKER; 32A; 1 POLE	CB1 A-HTR
2	1	EL-191	CIRCUIT BREAKER; 32A; 1 POLE	CB1 R-HTR
3	1	EL-191	CIRCUIT BREAKER; 32A; 1 POLE	CB3 HOSE
4	1	EL-186	SINGLE POLE; 3 AMP BREAKER	CB4 CNTL
5	1	EL-146	TERMINAL BLOCK; 16MM; GRND	GRD
6	2	EL-152	END STOP; 35MM	-
7	1	EL-142	TERMINAL BLOCK; 12MM	7
8	1	EI-143	TERMINAL BLOCKL; 16MM	L1
9	1	EI-143	TERMINAL BLOCKL; 16MM	L2
10	1	EI-143	TERMINAL BLOCKL; 16MM	L3
11	1	EL-143	TERMINAL BLOCKL; 16MM	N
12	1	EL-143	TERMINAL BLOCKL; 16MM	N

Point to Point Diagrams

Incoming Power

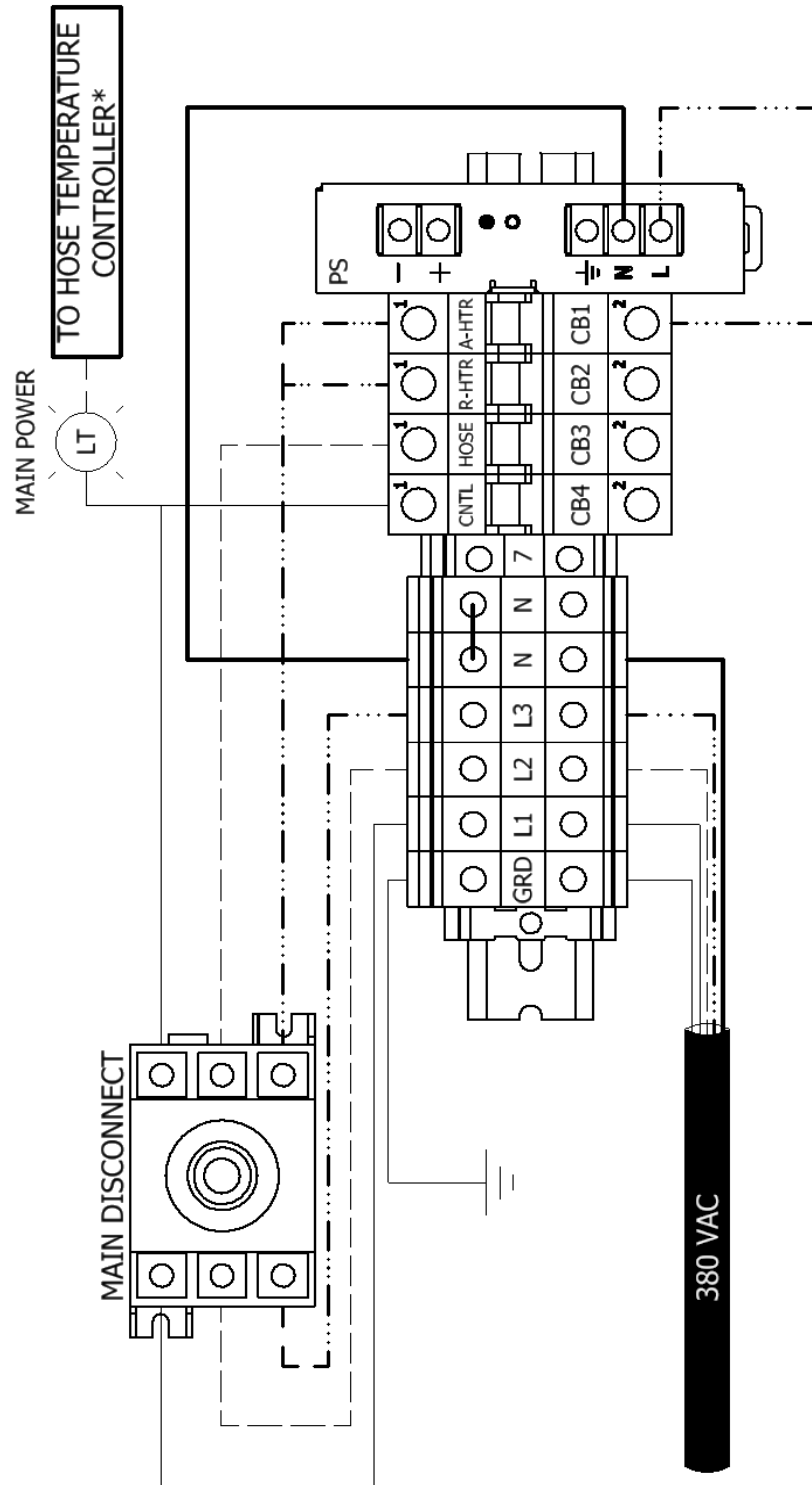

*See Heater Circuit on page 28.

Heater Circuit

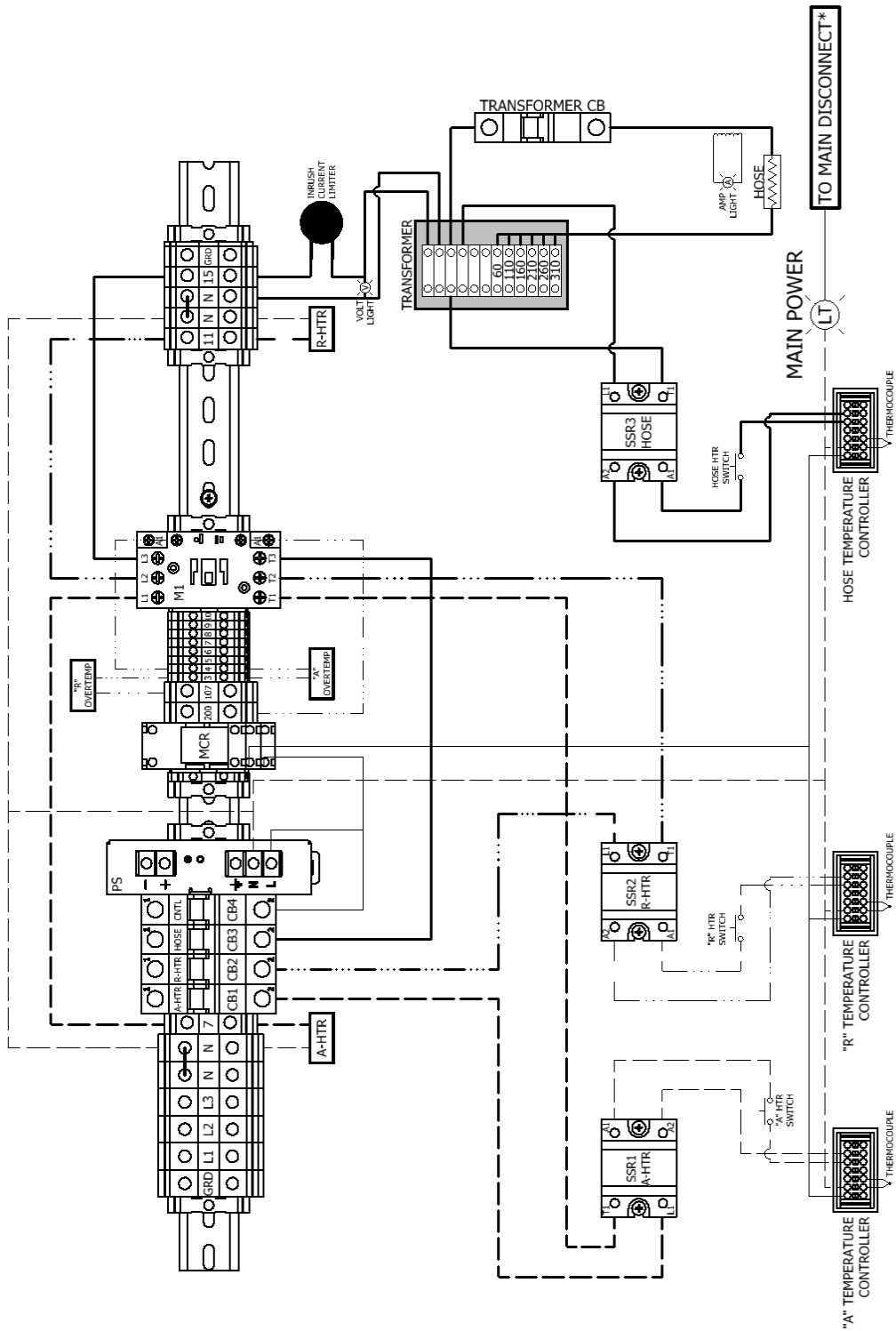

*See Incoming Power on page 27.

Ladder Diagrams

Incoming Power

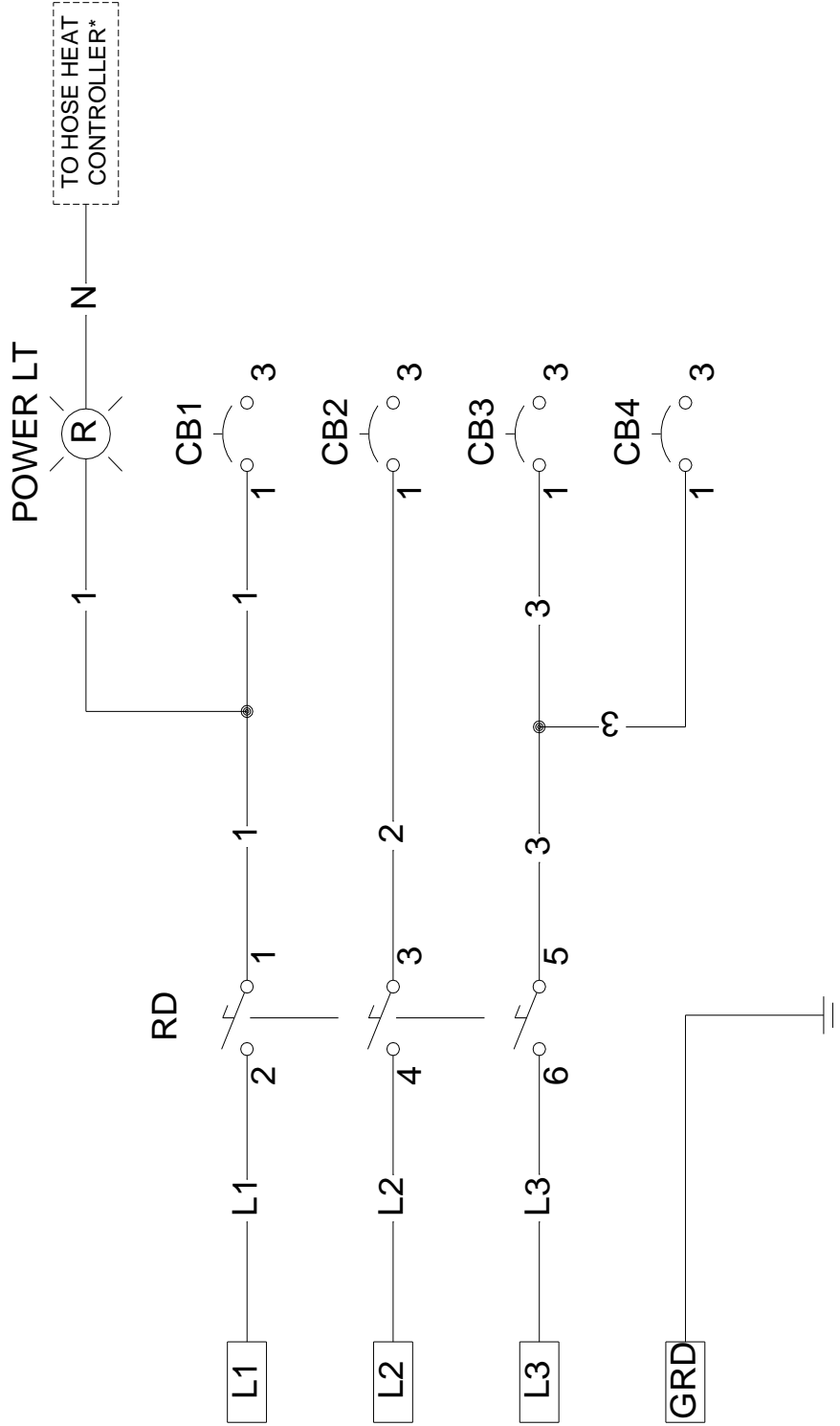

*See Heater Circuit on page 31.

Heater Circuit

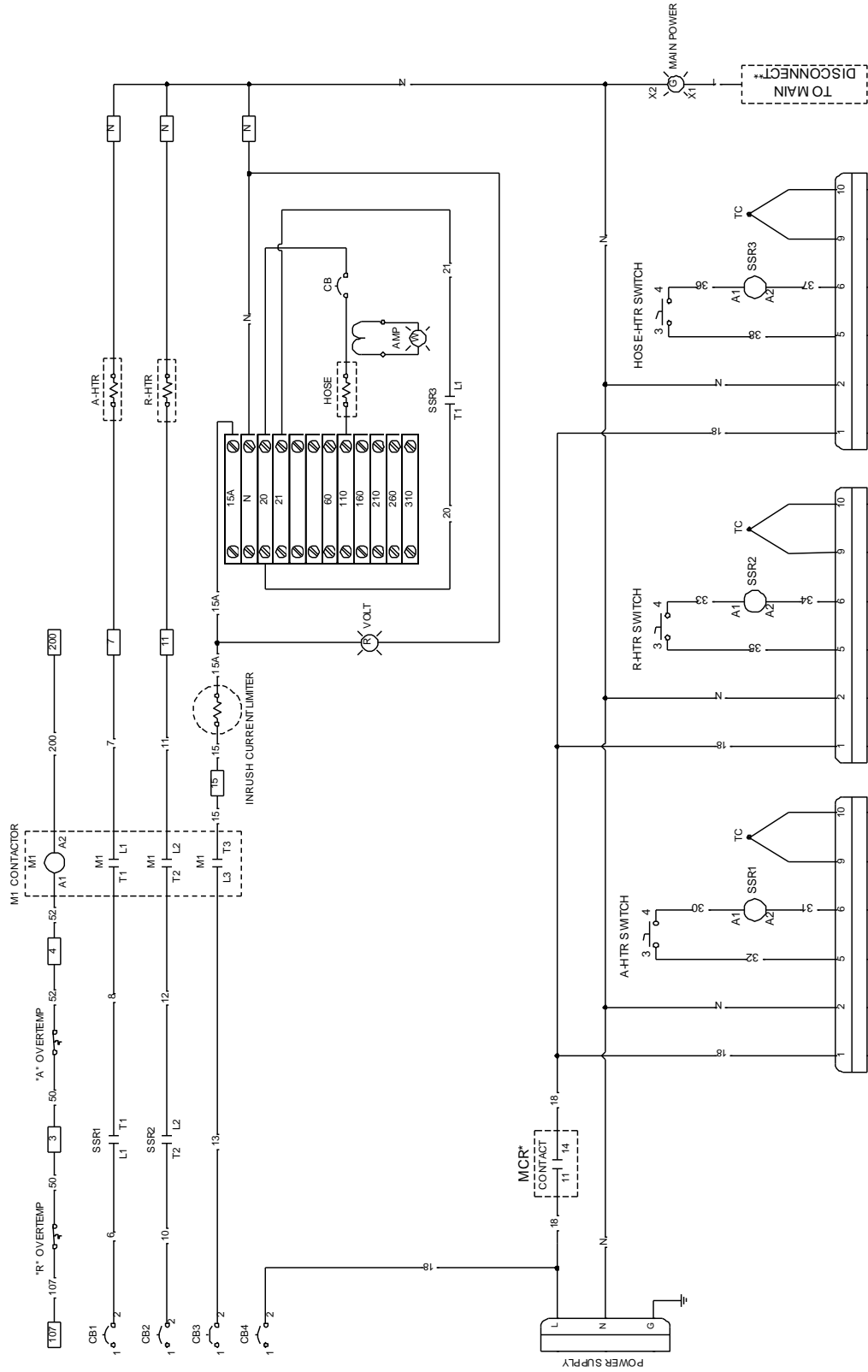

*See 24 VDC Power Circuit on page 32 for complete MCR wiring
 **See Incoming Power on page 30.

24 VDC Power Circuit

