

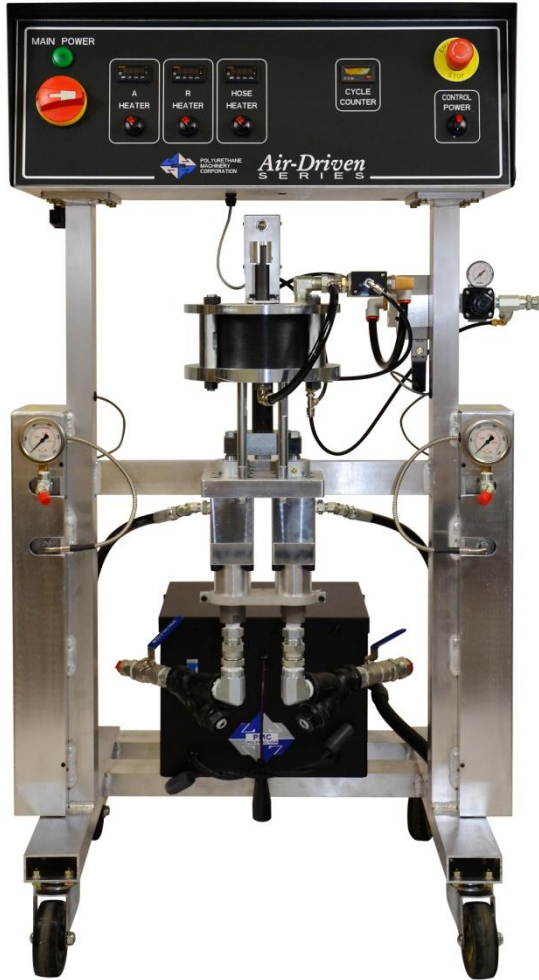

POLYURETHANE MACHINERY CORPORATION



PA-25/PAX-25 Proportioner Manual

**Pneumatic, Heated, Plural Component
Proportioner**

**For spraying Polyurethane Foam and
Coatings**

For Professional Use Only

Not approved for use in

Explosive atmosphere locations

Ref. # MN-06002

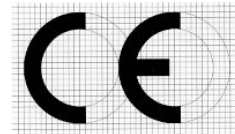

REVISION 1.0

Polyurethane Machinery Corp.

Headquarters: 1 Komo Drive, Lakewood NJ 08701

Manufacturing: 2 Komo Drive, Lakewood, NJ 08701

Phone: 732-415-4400

Fax: 732-364-4025

<http://www.polymac-usa.com>



Before installing the PA Series Proportioner and start-up, carefully read all the technical and safety documentation included in this manual. Pay special attention to the information in order to know and understand the operation and the conditions of use of the PA Series Proportioner. All of the information is aimed at improving user safety and avoiding possible breakdowns from the incorrect use of the PA Series Proportioner.



PA-25/PAX-25 Manual

TABLE OF CONTENTS

| | |
|---|-----------|
| WARRANTY | 3 |
| SAFETY AND HANDLING | 5 |
| CHARACTERISTICS | 8 |
| TECHNICAL SPECIFICATIONS | 9 |
| DESCRIPTION | 10 |
| INSTALLATION | 14 |
| PROPORTIONER PURGING | 19 |
| DIGITAL TEMPERATURE CONTROLLER | 21 |
| START-UP | 22 |
| SHUT-DOWN | 23 |
| TROUBLESHOOTING | 24 |
| HEATERS | 25 |
| HOSE HEAT | 28 |
| PNEUMATIC DRIVE SYSTEM | 31 |
| METERING PUMP LINE..... | 33 |
| MAINTENANCE | 35 |
| INLET MATERIAL SCREENS..... | 35 |
| METERING PUMP LINE..... | 37 |
| MATERIAL HEATER | 38 |
| REPLACEMENT PARTS | 40 |
| TECHNICAL SERVICE BULLETIN | 62 |
| MANUAL REVISIONS | 65 |



PA-25/PAX-25 Manual

WARRANTY

Polyurethane Machinery Corporation (hereinafter “PMC”) provides this LIMITED WARRANTY (hereinafter “Warranty”) to the original purchaser (hereinafter “Customer”) covering this equipment and the original PMC manufactured accessories delivered with the equipment (hereinafter “Product”) against defects in material or workmanship of the Product (hereinafter “Defect” or “Defective”) for a period of one (1) year from the date of first purchase as shown on the original PMC invoice (hereinafter “Warranty Period”).

If during the Warranty Period under normal use, the Product is suspected by Customer to be Defective in material or workmanship, it is Customer’s responsibility to contact PMC and return the Product to PMC as directed by PMC, freight prepaid. If PMC determines that the Product is Defective and that such Defect is covered by this Warranty, PMC will credit Customer for the reasonable freight charges incurred by Customer in returning the Defective Product to PMC, and PMC (or its authorized agent) will, at PMC’s option, repair or replace the Product, subject to the following:

Original Invoice: The original invoice must be kept as proof of the date of first sale and the Product serial number. The Warranty does not cover any Product if the Original Invoice appears to have been modified or altered, or when the serial number on the Product appears to have been altered or defaced.

Product Maintenance: It is the Customer’s responsibility to maintain the Product properly. See your maintenance schedule and owner’s manual for details. The Warranty does not cover an improperly maintained Product.

Non-PMC Components and Accessories: Non-PMC manufactured components and accessories that are used in the operation of the Product are not covered by this Warranty. Such components and accessories shall be subject to the warranty offered to the Customer, if any, by the original manufacturer of such component or accessory.

Other Warranty Exclusions: The Warranty does not cover any Product that PMC determines has been damaged or fails to operate properly due to misuse, negligence, abuse, carelessness, neglect, or accident. By way of example only, this includes:

- Normal wear and tear.
- Improper or unauthorized installation, repair, alteration, adjustment or modification of the Product.
- Use of heating devices, pumping equipment, dispensers, or other parts or accessories with the Product that have not been approved or manufactured by PMC.
- Failure to follow the operating instructions and recommendations provided by PMC.
- Cosmetic damage.
- Fire, flood, “acts of God,” or other contingencies beyond the control of PMC.



PA-25/PAX-25 Manual

THE WARRANTY DESCRIBED HEREIN IS THE EXCLUSIVE REMEDY FOR THE CUSTOMER AND IS IN LIEU OF ALL OTHER WARRANTIES, EXPRESS, IMPLIED, STATUTORY OR OTHERWISE, AND THE IMPLIED WARRANTIES OF MERCHANTABILITY AND FITNESS FOR A PARTICULAR PURPOSE AND ALL OTHER WARRANTIES ARE HEREBY DISCLAIMED. TO THE FULLEST EXTENT PERMITTED BY LAW, PMC SHALL NOT BE RESPONSIBLE, WHETHER BASED IN CONTRACT, TORT (INCLUDING, WITHOUT LIMITATION, NEGLIGENCE), WARRANTY OR ANY OTHER LEGAL OR EQUITABLE GROUNDS, FOR ANY CONSEQUENTIAL, INDIRECT, INCIDENTAL, LOST PROFITS, SPECIAL, PUNITIVE OR EXEMPLARY DAMAGES, WHETHER TO PERSON OR PROPERTY, ARISING FROM OR RELATING TO THE PRODUCT, EVEN IF PMC HAS BEEN ADVISED OF THE POSSIBILITY OF SUCH LOSSES OR DAMAGES.

Non-Warranty Service by PMC: If PMC determines that the suspected Defect of the Product is not covered by this Warranty, disposition of the Product will be made pursuant to the terms and conditions of PMC's written estimate on a time and materials basis.

Continuing Warranty for Products Repaired or Replaced under Warranty: Following the repair or replacement of a Product covered by this Warranty, such Product will continue to be subject to the original Warranty for the remainder of original Warranty Period or for three (3) months from the repair or replacement date, whichever is longer.

No Rights Implied: Nothing in the sale, lease or rental of any Product by PMC shall be construed to grant any right, interest or license in or under any patent, trademark, copyright, trade secret or other proprietary right or material owned by anyone; nor does PMC encourage the infringement of same.

Exclusive Warranty: This writing is the final, complete, and exclusive expression of the Warranty covering the Product. Any statements made by PMC, its employees or agents that differ from the terms of this Warranty shall have no effect. It is expressly understood that Customer's acceptance of this Warranty, by performance or otherwise, is upon and subject solely to the terms and conditions hereof, and any additional or different terms and conditions proposed or expressed by Customer or anyone, whether in writing or otherwise, are null and void unless specifically agreed to in writing by an Officer of PMC.



PA-25/PAX-25 Manual

SAFETY AND HANDLING

This chapter contains important information on the safety, handling and use of your PA Series Proportioner.



Before installing the PA Series Proportioner and start-up, carefully read all the technical and safety documentation included in this manual. Pay special attention to the information to know and understand the operation and the conditions of use of the PA Series Proportioner. All of the information is aimed at enhancing User Safety and avoiding possible breakdowns derived from the incorrect use of the PA Series Proportioner.

WARNING! Presents information to alert of a situation that might cause serious injuries if the instructions are not followed.

CAUTION Presents information that indicates how to avoid damage to the Proportioner or how to avoid a situation that could cause minor injuries.

NOTE! Is relevant information of a procedure being carried out.

Careful study of this manual will enable the operator to know the characteristics of the PA Series Proportioner and the operating procedures. By following the instructions and recommendations contained herein, you will reduce the potential risk of accidents in the installation, use or maintenance of the PA Series Proportioner; you will provide a better opportunity for incident-free operation for a longer time, greater output and the possibility of detecting and resolving problems fast and simply.

Keep this Operations Manual for future consultation of useful information at all times. If you lose this manual, ask for a new copy from your PMC authorized distributor or go online at our web site (www.polymac-usa.com).



PA-25/PAX-25 Manual

The PA Series Proportioner has been designed and built for the application of Polyurea chemical systems, polyurethane foam chemical systems and some two-component epoxy systems.

WARNING! The design and configuration of the PA Series Proportioner does not allow its use in potentially explosive atmospheres or the pressure and temperature limits described in the technical specifications of this manual to be exceeded.

Always use liquids and solvents that are compatible with the unit. If in doubt, consult your PMC authorized distributor.

When working with the PA Series Proportioner, it is recommended that the operator wear suitable clothing and elements of personal protection, including, without limitation, gloves, protective goggles, safety footwear and face masks. Use breathing equipment when working with the PA Series Proportioner in enclosed spaces or in areas with insufficient ventilation. The introduction and follow-up of safety measures must not be limited to those described in this manual. Before starting up the PA Series Proportioner, a comprehensive analysis must be made of the risks derived from the products to be dispensed, the type of application and the working environment.



PA-25/PAX-25 Manual



To prevent possible injury caused by incorrect handling of the raw materials and solvents used in the process, carefully read the Material Safety Data Sheet (MSDS) provided by your supplier.
Deal with waste caused according to current regulations.
Pour éviter toute blessure causée par une mauvaise manipulation des matières premières et les solvants utilisés dans le processus, veuillez lire attentivement la fiche signalétique (MSDS) fournies par votre fournisseur.
Traiter les déchets causés selon la réglementation en vigueur.



To avoid damage caused by the impact of pressurized fluids, do not open any connection or perform maintenance work on the components subject to pressure until the pressure has been completely eliminated.
Pour éviter les dommages causés par l'impact des fluides sous pression, ne pas ouvrir un lien ou d'effectuer des travaux d'entretien sur les éléments soumis à la pression jusqu'à ce que la pression a été complètement éliminé.



Use suitable protection when operating, maintaining or being present in the area where the equipment is functioning. This includes, but is not limited to, the use of protective goggles, gloves, shoes and safety clothing and breathing equipment.



Utiliser une protection appropriée utilisation, d'entretien ou d'être présents dans la région où le matériel fonctionne. Cela inclut, mais n'est pas limité à, l'utilisation de lunettes de protection, gants, chaussures et vêtements de sécurité et un équipement respiratoire.



The equipment includes components that reach high temperatures and can cause burns. Hot parts of the equipment must NOT be handled or touched until they have cooled completely.
L'équipement comprend des éléments qui atteignent des températures élevées et peuvent provoquer des brûlures. Les parties chaudes de l'équipement ne doit pas être manipulé ou touché jusqu'à ce qu'ils aient complètement refroidi.



To prevent serious injury through crushing or amputation, do not work with the equipment without the safety guards installed on the moving parts. Make sure that all the safety guards are correctly reinstalled at the end of the repair or maintenance work of the equipment.
L'équipement comprend des éléments qui atteignent des températures élevées et peuvent provoquer des brûlures. Les parties chaudes de l'équipement ne doit pas être manipulé ou touché jusqu'à ce qu'ils aient complètement refroidi.





PA-25/PAX-25 Manual

CHARACTERISTICS

The PA series Proportioner has been designed and built for the application of Polyurea chemical systems, polyurethane foam chemical systems and some specific two-component epoxy systems.

Principal Heating System

The Proportioner consists of two (2) independent Material Heater without internal seals. Each Heater has three (3) Heating Elements rated 1250 watts each giving the Proportioner a total heat of 7500 watts and the necessary control and safety components for their precise operation. The Material Heater design allows a temperature differential (ΔT) of 53° F (12° C) and material application temperatures of up to 190° F (88 ° C) under normal ambient temperatures.

Hose Heating System

The system is designed with a 3 KVA (90 V) Isolation Transformer that enables effective heating of up to a total hose length of 310 feet (94.5 meters). The system includes an innovative hose heating concept in which the continuous braid tinned-copper jacket is distributed evenly around the circumference of the hose providing a uniform heating watt density and precise control of the material application temperature. This hose heating element design is extremely resistant to fatigue failure.

100% circumferential coverage produces the most uniform distribution of heat available.

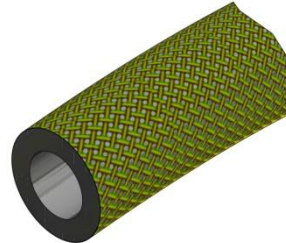

It is recommended to use PMC manufactured hose with all PMC Proportioners to get maximum Hose Heat operation.

Low Pressure Hoses - 2200 psi (152 Bar)

Part # MA-00014A

Part # MA-00014A-TC

Part # MA-00040A (10' whip, used for high pressure or low pressure)

High Pressure Hoses – 3500 psi (241 Bar)

Part # MA-00039A

Part # MA-00039A-TC

Double Acting Piston Metering Pumps

The double acting vertical mounted Pump Line is driven by a Pneumatic Cylinder. The vertical line provides a constant volume and delivers on ratio product in both directions of pump movement.



PA-25/PAX-25 Manual

TECHNICAL SPECIFICATIONS

Electrical

Main Voltage..... 1 x 208-230V, 50/60Hz
 Electrical Consumption (7500 watt Heater) 48 A @ 1 x 208-230V
 Material Heater Power..... 7.5 kW
 Hose Transformer Power3 KVA (90 V)



CAUTION! Inside the console, is a Terminal Strip for connecting the main power (wire not supplied) to the PA Series Proportioner. Use the appropriate AWG wire. This electrical connection must be made only by a qualified electrician.

Mechanical

Maximum working pressure (1.23 pumps) @ 100 psi (6.9 bar) input1600 psi (110.3 bar)
 @ 110 psi (7.6 bar) input.....800 psi (55.2 bar)
 Use PMC Low Pressure Heated Hoses: MA-00014A and MA-00014A-TC
 Maximum working pressure (.61 pumps) @ 100 psi (6.9 bar) input3200 psi (220.6 bar)
 Use PMC High Pressure Heated Hoses: MA-00039A and MA-00039A-TC
 Maximum production @ ratio 1:1 (60 pumps)..... 1.8 gals/min (6.8 L/min)
 Maximum production @ ratio 1:1 (40 pumps)..... 1.2gals/min (4.5 L/min)
 Minimum production 0.2 gal/min (0.8 L/min)
 Maximum hose length310 ft
 Dimensions..... 30in W x 26in D x 45in H

| Machine | Pump size | Cycles per Gallon | Cycles per Liter | Pressure to Air Ratio | Stroke |
|---------|--------------|-------------------|------------------|-----------------------|--------|
| PA-25 | 1.23 (1.227) | 23.47 | 88.84 | 16:1 | 2" |
| PAX-25 | .61 (6.135) | 47.33 | 179.76 | 30:1 | 2" |

NOTE! The PA Series is designed to be used with the PMC Spray Gun (3500 PSI) or equivalent that is rated to the maximum pressure rating of the model being used. Refer to the spray gun manual.



PA-25/PAX-25 Manual

DESCRIPTION

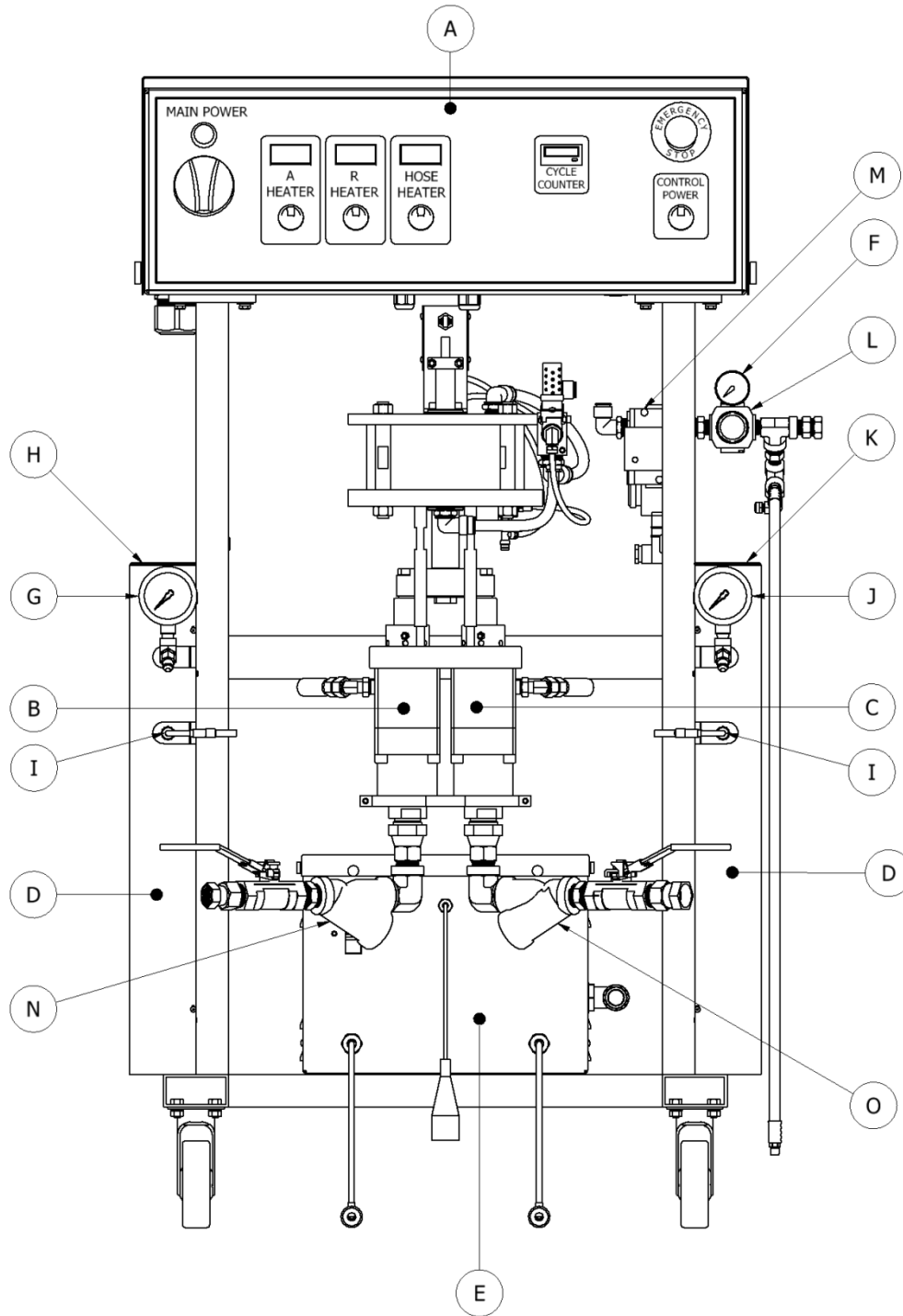



PA-25/PAX-25 Manual

A. Control Panel

Controls and regulates the operation of the PA Series Proportioner.

B. Isocyanate (Iso “A”) Metering Pump

Meters the Isocyanate material.

C. Polyol (Poly “R”) Metering Pump

Meters the Polyol material.

D. Heaters

Heats the incoming chemical to a temperature set by the operator.

E. Hose Heating Transformer

Supplies the required voltage for material Heated Hoses.

F. Pneumatic Pressure Gauge

Indicates the pressure in the Pneumatic Drive System.

G. Isocyanate (Iso “A”) Pressure Gauge

Indicates the pressure in the Isocyanate system.

H. Isocyanate (Iso “A”) Safety Pressure Switch

Disables the pump circuit in the event of excessive pressure in the Isocyanate system (not shown) located in the back of the heater.

I. Heater Thermocouples

Provides temperature information of the chemical to its Temperature Controller.

J. Polyol (Poly “R”) Pressure Gauge

Indicates the pressure in the Polyol system.

K. Polyol (Poly “R”) Safety Pressure Switch

Disables the pump circuit in the event of excessive pressure in the Polyol system (not shown) located in the back of the heater.

L. Pneumatic Pressure Control

Allows the pressure of the pneumatic system to be increased or decreased. Turn clockwise to increase the pressure and counterclockwise to decrease. To pressure up the machine the Control switch must be on.

M. Solenoid Valve

Will shut off the air supply if an over pressure occurs or the emergency stop is utilized.

N. Y-Strainer “A”

Filters material from the bulk supply.

O. Y-Strainer “R”

Filters material from the bulk supply.



PA-25/PAX-25 Manual

P. Retract Ball Valve

Moves the piston shaft down into its cylinder further than it would travel in the operational mode. This protects the packing from any hardened material that may have formed on the Isocyanate shaft.

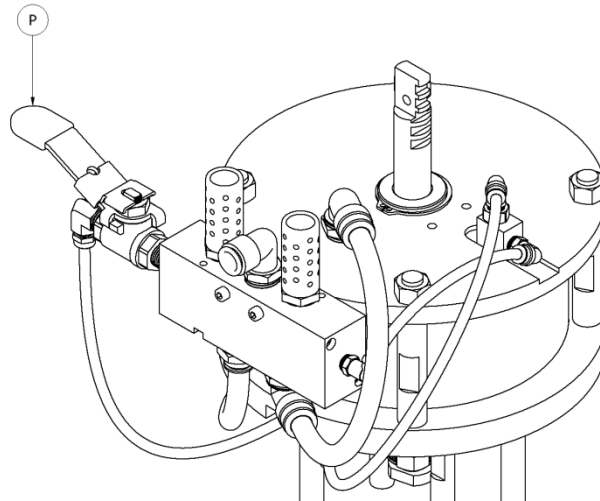

NORMAL POSITION (OPEN)

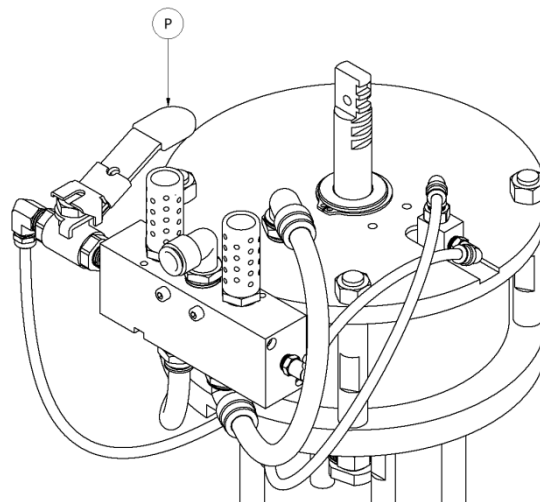

RETRACT POSITION (CLOSED)



PA-25/PAX-25 Manual

Control Panel

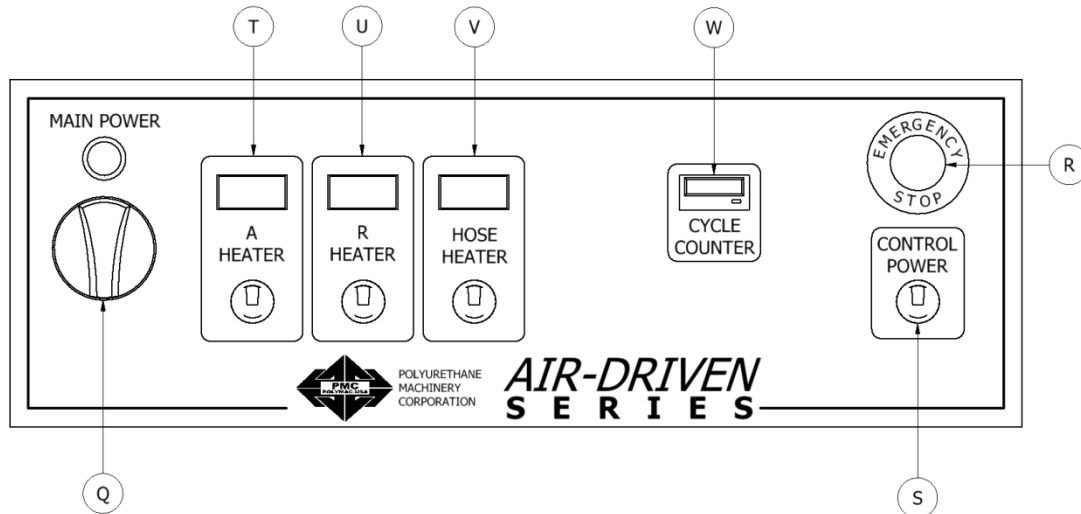

Q. Main Power

Turns ON and OFF main power to the control panel. It must be turned ON for any operation to be performed with the unit. When turned ON, the red pilot will light.

R. Emergency Stop

Interrupts complete PA Series control power circuit thus allowing NO power to the Heaters, Hose or Air control system.

S. Control Power

The Control Power Switch only controls power necessary for any proportioner functions to operate. In the ON position the temperature controllers will display the temperature and the main machine display will illuminate.

T. “A” Heater Controller Switch and controller zone

Turns ON and OFF power to the “A” Heater. See detailed Temperature Controller instructions.

U. “R” Heater Controller Switch and controller zone

Turns ON and OFF power to the “R” Heater. See detailed Temperature Controller instructions.

V. Hose Heater Control Switch and controller zone

Automatically controls the Hose Heater only when using the TSU (Temperature Sensing Unit) probe.

W. Cycle Counter

Used to calculate the amount of chemical processed.

| Machine | Pump size | Cycles per Gallon | Cycles per Liter |
|---------|--------------|-------------------|------------------|
| PA | 1.23 (1.227) | 23.47 | 88.84 |
| PAX | .61 (6.135) | 47.33 | 179.76 |



PA-25/PAX-25 Manual

INSTALLATION

WARNING! Use suitable protection and follow the recommendations in the Safety Information enclosed and provided by material suppliers when installing or working with the proportioner.

Inside the console is a Terminal Strip for connecting the incoming power cable (not supplied). Use appropriate AWG wire. The electrical connection of the proportioner must be carried out by a qualified electrician.

NOTE! To ensure the PA Series Proportioner works correctly, the electrical supply must meet the specifications indicated on the Serial Number Placard affixed to the Electric Console.



CAUTION! Make sure the power cable is disconnected from the main power source before connecting to the Terminal Strip in the Console.

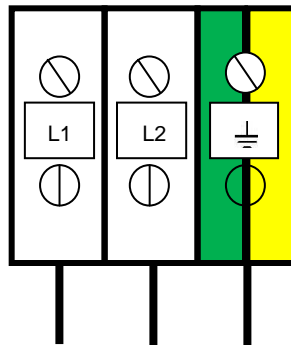

1 phase x (208- 230 Volt)

Follow the recommended procedure in the indicated order to install the proportioner:

1. Insert the main power cable by passing it through the strain relief at the bottom of the Electrical Console and connect as shown in the above diagram.



PA-25/PAX-25 Manual

Heated Hose Installation

CAUTION! The material delivery Heated Hoses are color coded Red and Blue allowing the user to recognize them. The Red corresponds to the Isocyanate (Iso “A”) and the Blue to the Polyol (Poly “R”). To avoid connection errors the Coupling Connections of the Iso “A” and Poly “R” Heated Hoses are also different sizes, which makes it difficult to swap connections.

NOTE! The material delivery Heated Hoses are capped at the ends to prevent absorbing moisture. Do not remove caps until the Heated Hoses are going to be installed on the proportioner.

2. Lay out all the Heated Hose assemblies end to end aligning the Iso (Red) and Poly (Blue) and connect the respective Coupling Connections using the appropriate sized open-end wrench after ensuring Heated Hose assemblies lay flat.

CAUTION! Take care to not cross-thread or over-tighten the Coupling Connections. Thread sealant tape or compound is not required for this tapered seat Coupling Connections.

3. Connect the material Heated Hoses to the outlets of the respective Heater connections i.e. Iso “A” Heated Hose to the Iso “A” Heater connection and the Poly “R” Heated Hose to the Poly “R” Heater connection ensuring the Heated Hose assemblies lay flat.
4. Connect Air Hose Coupling Connections.
5. Connect the Heated Hose power wires to the “Fast-Lock” Connector coming from the Hose Heat Transformer as follows:
 - a. Loosen the Socket Head Set Screw to allow insertion of the Heated Hose electrical wire Terminal.
 - b. Insert the Terminal into the “Fast-Lock” Connector Body.
 - c. Securely tighten the Socket Head Set Screw.

NOTE! Install electrical tape around Connector Body.

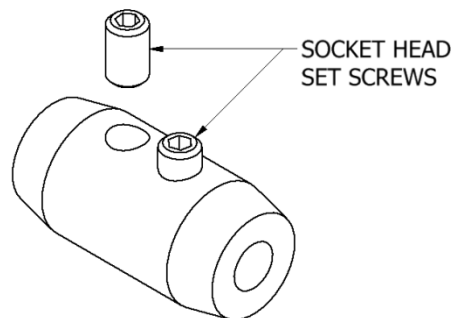

FAST-LOCK CONNECTION
PART # KT-00029A



PA-25/PAX-25 Manual

NOTE! A good practice is to add some dielectric grease (Permatex 67VR or equivalent) to the outside of the Terminal prior to insertion.

Repeat the above steps to connect the “Fast-Lock” Connectors that you will find on all Heated Hose power wire. NOTE: All PMC heated hose wire is # 6 AWG.

CAUTION! Ensure the proper mechanical and electrical connections of the Heated Hoses are made to avoid possible material leakage and hose heat problems.

6. It is recommended the TSU be installed between the last section of Heated Hose and the Gun Whip. Carefully straighten the sensing wire, inserting it in the Iso “A” Heated Hose and tighten fluid fittings with appropriate sized open-end wrenches.

CAUTION! To protect the TSU sensor, you must pay special attention not to kink or excessively bend the Heated Hoses. Do not coil the Heated Hoses with a diameter of less than 4 feet.

CAUTION! Connecting the TSU between the first and second section of Heated Hose results in the TSU sensing the material temperature exiting the Heater and not the inside of the Heated Hose near the Spray Gun.

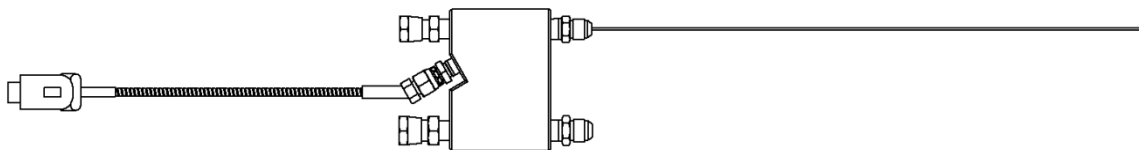

Temperature Sensing Unit
(TSU) Part # EL-51A
Replacement Sensor Part # EL-51A-2



PA-25/PAX-25 Manual

TRANSFORMER SETTINGS

The Hose Heat Transformer offers the ability of connecting to different output voltages depending on the total length of the Heated Hose in use, maximizing the heating ability of the Heated Hose. The factory setting is 18 volts for use with 60 feet (18.3 meters) of Heated Hose. Before starting the proportioner, ensure the setting matches the Heated Hose length installed. If Heated Hose sections are added or removed, the Tap setting should be changed to a setting which will limit the maximum amperage in the Heated Hose to 52 amps. The suggested settings are tabled below:

(MINIMUM HOSE LENGTH 45 feet (13.7 meters))

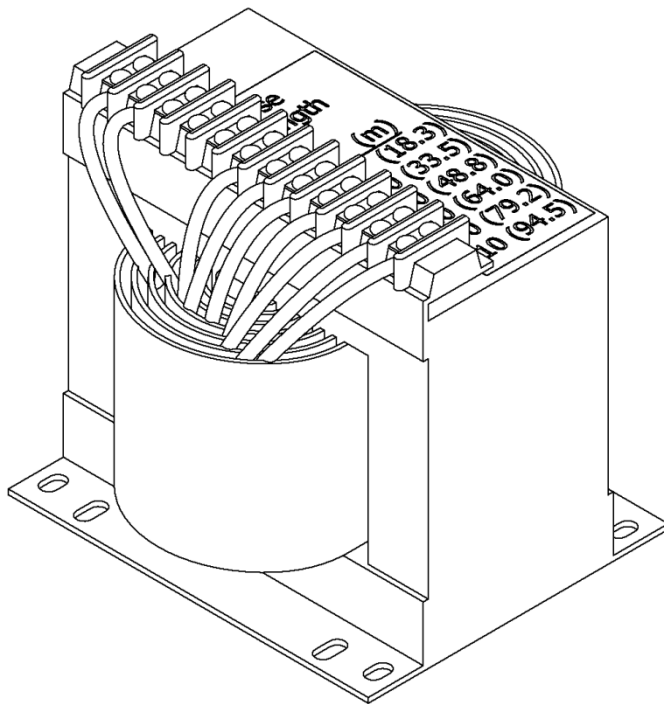

| Tap | Feet | Meters |
|-----|------|--------|
| 90v | 310 | 94.5 |
| 75v | 260 | 79.5 |
| 60v | 210 | 64.0 |
| 45v | 160 | 48.8 |
| 30v | 110 | 33.5 |
| 18v | 60 | 18.3 |

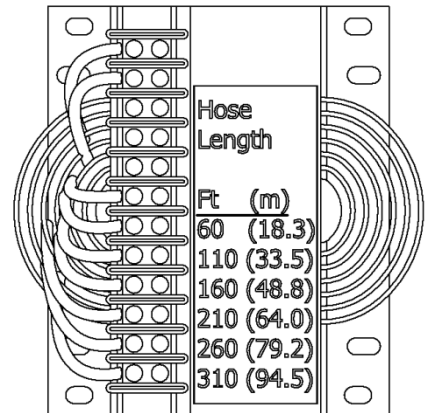

7. Ensure the Manual Valves are CLOSED and connect the Coupling Block to the Heated Gun Whip.

CAUTION! Excessive force closing or opening the Manual Valves may result in damage to the Manual Valves and/or Coupling Block.

8. Connect the Transfer Pump/Heated Hose Assemblies air supply and air dryer and systems as required. Review the Installation Instructions for each to ensure proper set-up operation.
9. Install the Material Transfer Pumps as follows:



PA-25/PAX-25 Manual

WARNING! If Transfer Pumps have been previously used, pay special attention to connect each Pump to “its” specific material. Inadvertently changing the Transfer Pumps will cause a chemical reaction rendering them useless.

NOTE! Placing a tape of the same color as of the Material Delivery Hoses (red for the Iso “A”, blue for the Poly “R”) on each Transfer Pump would be a good method for minimizing errors in connection.

- a. Make sure that the Inlet Valves on the Proportioner are closed.
- b. Connect one end of the Polyol “R” Material Delivery Hose ($\frac{3}{4}$ ” thread) to the proportioner Polyol “R” Inlet Valve and the other end to the Polyol “R” Transfer Pump.
- c. Connect one end of the Iso “A” Material Delivery Hose ($\frac{1}{2}$ ” thread) to the proportioner Iso “A” Inlet Valve and the other end to the Iso “A” Transfer Pump.
- d. Connect the air hose to the Transfer Pumps after ensuring each Transfer Pump Shut-Off Valve is CLOSED.
- e. Connect air to the air hose on the first section of heated hose, 90-120 psi (6.2 - 8.3 bar)

NOTE! To avoid errors in connection, the Coupling connections of the Iso “A” and Poly “R” Material Delivery Hoses are different sizes, making it difficult to swap connections.

CAUTION! Ground the Transfer Pump as recommended by the material supplier. The movement of product inside the Hoses can cause static electricity and produce electrical discharges.

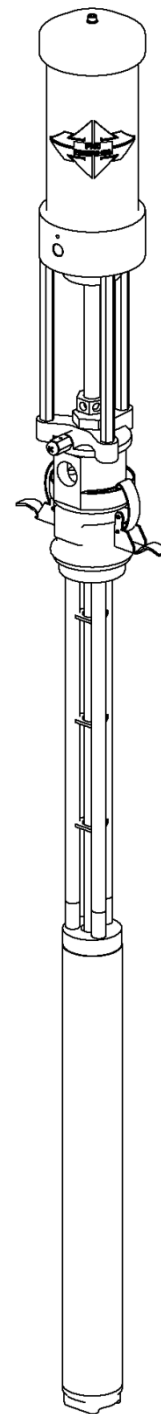



PA-25/PAX-25 Manual

PROPORTIONER PURGING



CAUTION! Use suitable Personal Protection Equipment (PPE)



CAUTION! Follow the recommendations in the Safety Information provided by product suppliers when installing or working with the unit.

NOTE! Before using the Proportioner it is necessary to purge the entire system, including Heated Hoses of mineral oil left over from Quality Control testing and air. The following procedure is also followed to purge air entrapped by running out of material in the supply Drum/Reservoirs resulting in a significant indicated material pressure imbalance as indicated by the Pressure Gauges and sprayed material.

1. Ensure the following before proceeding:
 - a. Air supply to Transfer Pumps is 90 - 110 psi (6.2 – 7.6 bar).
 - b. Proportioner Inlet Valves are CLOSED.
 - c. All connections are tight.
 - d. Material should be stored to the material suppliers' recommended temperatures.
2. Slowly OPEN the Poly "R" Transfer Pump Air Shut-Off Valve allowing Pump to cycle slowly as it fills the Material Delivery Hose to the Proportioner. Check for leaks.
3. OPEN Poly "R" Coupling Block Manual Valve over a waste container.
4. Slowly OPEN Proportioner Poly "R" Inlet Valve allowing Transfer Pump to move material through the system. When all spitting of air stops and all traces of mineral oil have disappeared, CLOSE Poly "R" Coupling Block Manual Valve.
5. Clean Coupling Block.
6. Repeat steps 2 to 4 for Iso "A" side.

CAUTION! Properly dispose of all waste chemicals in accordance with all applicable local, state and federal codes.

7. Turn Pneumatic Pressure Control (L, page 11) full COUNTERCLOCKWISE.
8. Turn the retract ball valve (P, page 12) to the open position.
9. Attach air supply to the pressure control regulator (L, page 11)
10. Turn on compressor or air supply.
11. Turn ON Main Power (Q, page 13). Red pilot will light.
12. Turn ON Control Power (S, page 13). Red pilot will light.



PA-25/PAX-25 Manual

13. Turn the Pneumatic Pressure Control CLOCKWISE increasing **material pressure** to 400 psi (27.6 bar). Both Material Pressure gauges (G, J, page 11) should read the same. **Check all Heated Hose Coupling connections for leakage.**
14. Check the TSU for leaks and that all “Fast-Lock” connections are tight and electrical tape is installed over their set screws.
15. Bundle all Heated Hose Connections ensuring no TSU Cable or Air Hose kinks. Wrap with Electrical Tape to securely hold all components in place and minimize places for bundle to snag onto job site protrusions.







PA-25/PAX-25 Manual

DIGITAL TEMPERATURE CONTROLLER

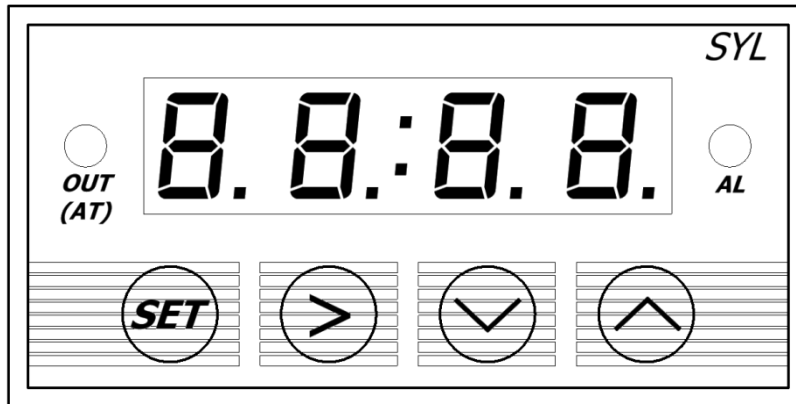
The PA Series has three (3) Digital Temperature Controllers to manage the temperatures for the Primary Heaters and the Heated Hose. The Hose Heater Controller is programmed different from the heater Controllers and therefore not interchangeable with them.

WARNING! Do not turn the Temperature Controllers ON until the Proportioner Purging procedure is complete and the Primary Heaters and Heated Hoses are filled with material.



1. Ensure Main Power is ON, Control Power is ON.
2. Press and release  or  button. The display will flash and indicate its current set point.
3. Press and hold the  or  to increase or decrease the material temperature set-point to the desired value as determined by the material supplier or application conditions.
4. Once the set point is entered the controller will go back to ambient temperature on its own. (5-8 seconds)

WARNING! The Controllers are factory programmed and are not field re-programmable. If a problem is encountered, contact your PMC authorized distributor. Do not attempt to change any of the programmed parameters. Do not substitute a Controller from an alternate supplier as its use may result in equipment damage and/or bodily injury.

NOTE! The Temperature Controller normally displays the actual material temperature.



PA-25/PAX-25 Manual

START-UP

NOTE! Follow the recommended procedures in the order shown.

CAUTION! The Start-up procedures assume that all of steps in Proportioner purging have been performed and no problems found.

1. Check that the “A” side proportioning pump has been lubed using the grease that has been supplied with the machine.
2. Make sure the materials have been stored at the manufacturer’s recommended temperature. Ask your material supplier for information (Material Data Sheet) on the minimum storage temperature.
3. Connect air supply to the two Transfer Pumps and ensure Air Valves are in the full OPEN position. OPEN both Proportioner Material Inlet Ball Valves.

CAUTION! Remove all Heated Hose sections from coiled storage and lay flat to eliminate heat build-up and possible Heated Hose failure.

4. Turn ON Main Power (Q, page 13).
5. Turn on the air supply.
6. Turn the retract ball valve (P, page 12) to the open position.
7. Turn ON Control Power (R, page 13).
8. Turn ON Hose and confirm the material set-point temperature is as recommended by the material supplier or application conditions.

CAUTION! To avoid excessive pressure in the Proportioner, wait for the Hose Heater to reach its set-point temperature before continuing.

9. Turn ON the Primary Heater and confirm material set-point temperature as required by the material supplier or application conditions has been reached.
10. Turn on the air supply.
11. Using the Pneumatic Pressure Control (air regulator), adjust to the required stall pressure[Ⓢ] and check each Material Pressure Gauge.
 - a. The Material Pressure Gauges should be approximately equal and remain constant throughout Metering Pump cycle.
12. Y strainer screens on the inlet of each pump should be checked once per week during start up.
13. Proceed with Installation and Start-up of the Spray Gun.

[Ⓢ] Stall pressure: When materials are at recommend application temperature and Metering Pumps are pressurized but not moving. This pressure is normally 100 – 200 psi (6.9 – 13.8 bar) greater than the developed spray pressure as recommended by the material supplier.



PA-25/PAX-25 Manual

SHUT-DOWN

Follow the recommended procedure in the indicated order for Proportioner temporary shut-down such as **lunch breaks**.

1. Shut off the air supply.
2. Turn the Heaters OFF. Hose Heater should remain ON. Never leave Proportioner ON if unattended.
3. CLOSE Spray Gun Manual Valves.

CAUTION! Excessive force opening or closing the Manual Valves may result in damage to the Manual Valves and/or Coupling Block.

Follow the recommended procedure in the indicated order for Proportioner shut-down when **work is stopped for the day**.

1. Turn the retract ball valve to the closed position. Spray off the application surface until Material Pressure Gauges readings begin to fall, stop spraying when the pump shaft are at the bottom of the cylinder.

CAUTION! To avoid possible Proportioning Pump Seal weepage, and moisture vapor drive into the Heated Hoses, the system pressure should not be reduced to zero. It is recommended to lower the system pressure to a minimum of 400 psi (27.6 bar).

2. CLOSE the Spray Gun Coupling Block Manual Valves. Refer to the Spray gun manual

CAUTION! Excessive force opening or closing the Manual Valves may result in damage to the Manual Valves and/or Coupling Block.

3. Turn OFF the Heater and Hose Heater.
4. Turn OFF the Control Power.
5. Turn OFF the Main Power.
6. Disconnect the air supply to the two Transfer Pumps and CLOSE the Proportioner Material Inlet Valves.



PA-25/PAX-25 Manual

TROUBLESHOOTING

The PA Series proportioner has been designed and built to withstand severe working conditions with a high degree of reliability, provided that it is used in a suitable application by a properly trained operator. This chapter contains information on possible faults that may interrupt the operation of the PA Series. The information provided will serve as a guideline to detect and resolve problems. In any case, feel free to contact your PMC authorized distributor where a qualified technician will advise you.

CAUTION! All repairs performed by unqualified personnel or the use of spares other than originals may cause damage to the unit and put the operator at risk.



To prevent possible injury caused by incorrect handling of the raw materials and solvents used in the process, carefully read the Material Safety Data Sheet (MSDS) provided by your supplier.

Deal with waste caused according to current regulations.

Pour éviter toute blessure causée par une mauvaise manipulation des matières premières et les solvants utilisés dans le processus, veuillez lire attentivement la fiche signalétique (MSDS) fournies par votre fournisseur.

Traiter les déchets causés selon la réglementation en vigueur.



To avoid damage caused by the impact of pressurized fluids, do not open any connection or perform maintenance work on the components subject to pressure until the pressure has been completely eliminated.

Pour éviter les dommages causés par l'impact des fluides sous pression, ne pas ouvrir un lien ou d'effectuer des travaux d'entretien sur les éléments soumis à la pression jusqu'à ce que la pression a été complètement éliminé.



Use suitable protection when operating, maintaining or being present in the area where the equipment is functioning. This includes, but is not limited to, the use of protective goggles, gloves, shoes and safety clothing and breathing equipment.



Utiliser une protection appropriée utilisation, d'entretien ou d'être présents dans la région où le matériel fonctionne. Cela inclut, mais n'est pas limité à, l'utilisation de lunettes de protection, gants, chaussures et vêtements de sécurité et un équipement respiratoire.



The equipment includes components that reach high temperatures and can cause burns. Hot parts of the equipment must NOT be handled or touched until they have cooled completely.

L'équipement comprend des éléments qui atteignent des températures élevées et peuvent provoquer des brûlures. Les parties chaudes de l'équipement ne doit pas être manipulé ou touché jusqu'à ce qu'ils aient complètement refroidi.



To prevent serious injury through crushing or amputation, do not work with the equipment without the safety guards installed on the moving parts. Make sure that all the safety guards are correctly reinstalled at the end of the repair or maintenance work of the equipment.

L'équipement comprend des éléments qui atteignent des températures élevées et peuvent provoquer des brûlures. Les parties chaudes de l'équipement ne doit pas être manipulé ou touché jusqu'à ce qu'ils aient complètement refroidi.



PA-25/PAX-25 Manual

HEATERS

WARNING! Before troubleshooting make sure the Main Power Switch is OFF and incoming power is locked OFF. NEVER access the inside of the Control Panel with the Proportioner power supply ON. The Heaters are components that reach high temperatures; you must wait until they cool before handling.

NOTE! The Thermal Limit Switch is a safety switch in contact with the Heater body. If the surface temperature exceeds 225° F (107° C) the Limit Switch will shut off the Heater power. The Limit Switch will not reset until the temperature in the Heater is below 190° F (88° C). The switch will disable the heaters and hose heat.

Follow the recommended procedure in the indicated order to solve the problem and avoid unnecessary repairs. Make sure all Switches are in the correct position and Indicator Lights ON before determining the existence of a fault.

WARNING! Before proceeding with any troubleshooting that requires power up of unit, ensure all testing is performed by a qualified electrician.

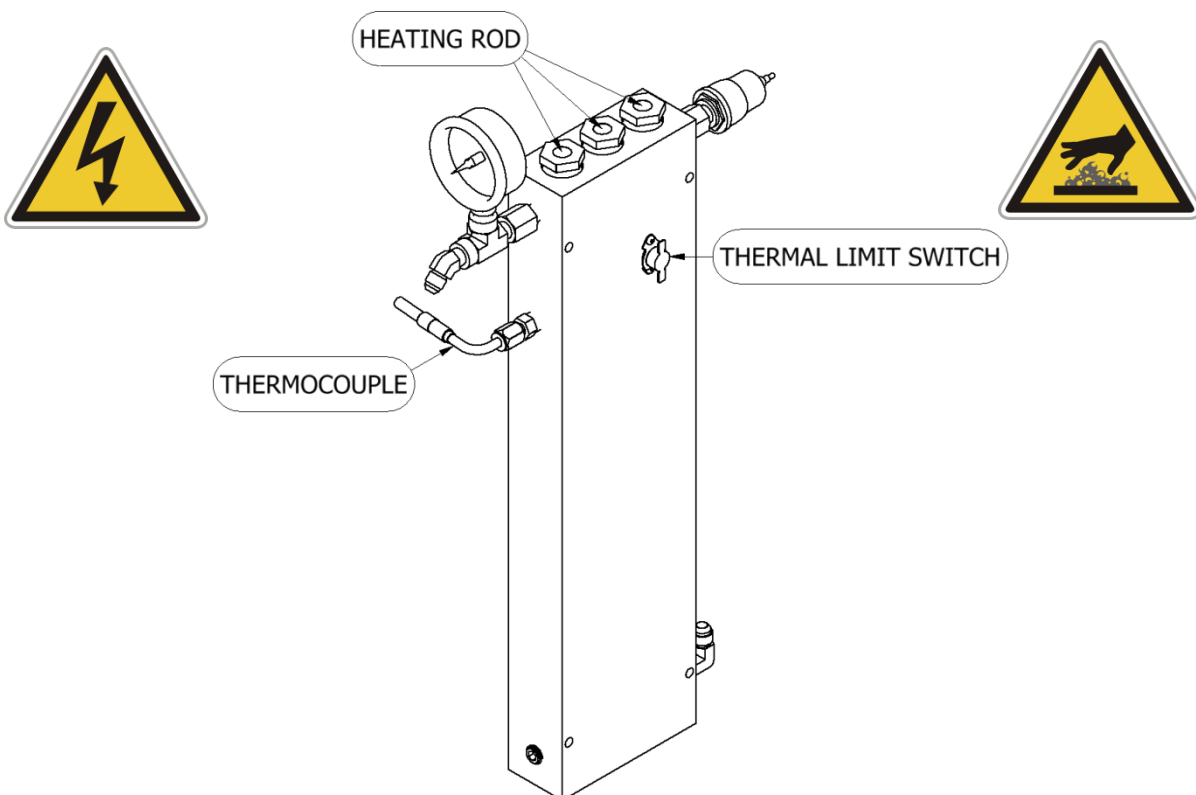



PA-25/PAX-25 Manual

PRIMARY HEATER

PROBLEM

Primary heater does not heat and the display on the controller shows ambient temperature.

SOLUTIONS

1. Check that the light on the OFF/ON switch is lit when the heater is turned on, if not replace the switch.

If the light is on, move to the next step.

2. Check the heater breaker in the main console, reset the breaker, if it continues to trip, wrap an amp clamp around one of the wires coming off the breaker if it does not exceed the rating of the breaker, the breaker needs to be replaced. If the breaker draws more than its rating the most likely cause is that one or more of the 1250 watt fire rods is shorted. Remove the heater cover, disconnect the wires and check each rod for resistance. **Each rod should read approximately 39.0 ohms.**

If the breaker is not tripped, move on to the next step.

3. Open the console top and locate the solid state relays for the heaters, looking over the console top from the front of the machine. There are two relay to the left bottom of the console, the one to the far left is for the "A" heater and the one to the right is for the "R" heater. With the heater on and there is a LED light lit on the relay take a volt meter that is set on AC volts and measure across position L1 and L2 (heavy wires). With the relay functioning properly you should have a 1 volt reading, if you have a 208-230 volt reading, the relay has malfunctioned and needs to be replaced. If the AC voltage reads zero remove the pre-heater cover and look for loose or broken wires.

If there is no LED light on the solid state relay, move to the next step.

4. With a DC volt meter read across position A1 and A2 on the solid state relay (smaller wires) if you have a reading of 4-6 volts DC replace the solid state relay.

If there is no DC voltage to the relay, move to the next step.

5. Using a DC volt meter measure across position 9 and 10 on the back of the heater controller this is the output of the controller and sends power to the solid state relay, your reading will be 4-6 volts DC if there is no reading check to make sure that the set temperature of the controller is above the actual temperature reading on the controller. Before replacing the controller read across position 1 and 2 to make sure that the controller is powered up, your reading will be 208 to 230 volts AC. If no voltage is present check for loose wires or a malfunction of the heater circuit breaker.

If there is power in and out of the controller, move to the next step.

6. Remove the heater top and check the over temperature limit switch for loose wires, if the wires are secure take a continuity reading across the switch.

If the switch is open (no continuity) replace the switch.



PA-25/PAX-25 Manual

PROBLEM

Primary heater does not heat and the display on the controller shows an error message.

SOLUTIONS

1. Check position 6 and 7 on the heater controller for loose wires.

If the wires are tight, move to the next step.

2. Remove the heater cover and check that the thermocouple wires are secure to the harness going up to the controller.

If there are no loose connections, replace the thermocouple.

PROBLEM

Primary heater controller shows excessive temperature and the circuit has turned off.

CAUTION! The heater must be allowed to cool down before continuing.

SOLUTIONS

1. Set the controller set point at least 20 degrees lower than the temperature shown on the controller. Briefly turn on the heater and look for the LED light on the solid state relay to be on.

If the light is on replace the controller.

If the light is off replace the solid state relay.

PROBLEM

Primary heater Temperature drops excessively while spraying.

SOLUTIONS

1. Temperature of the chemical in the containers is too cold.
2. Exceeding the flow rate specification of the machine.
3. **Disconnect power to the machine.**

One or more of the fire rods in the heater have malfunctioned. Remove the heater cover and take a resistance reading across the wires, **reading across the two sets of wires should read 13 ohms**. If you have a higher reading than one or more of the rods are not working. Disconnect the wires and read the resistance of each rod, **each one should approximately read 39 ohms**. Replace the damaged rod(s).



PA-25/PAX-25 Manual

HOSE HEAT

CAUTION! All electrical testing must be done by a qualified electrician.

PROBLEM

Heated hose does not heat and the display on the controller shows ambient temperature.

SOLUTIONS

1. Check that the light on the OFF/ON switch is lit when the heater is turned on, if not replace the switch.

If the light is on, move on to the next step.

2. Check the Hose Heat breaker in the main console. If the breaker continues to trip, reset it and wrap an amp clamp around one of the wires coming off the breaker. If it does not draw more than the rated value of the breaker, the breaker needs to be replaced.

If the breaker is not tripped move on to the next step.

3. Check the circuit breaker mounted on the transformer. If the breaker continues to trip, reset it and wrap an amp clamp around one of the wires from the transformer going to the heated hose. If it does not draw more than the rated value of the breaker, the breaker needs to be replaced.

If the breaker exceeds the rated value move on to the next step.

4. Check that the tap setting on the transformer is set for the proper hose length.

If it is set correctly, move to the next step.

5. Using a voltmeter set on AC volts, and the hose circuit turned on, measure across the two leads coming out of the transformer that are connected to the "A" and "R" hose. If you are reading voltage (your volt reading will vary depending on what tap setting is used) most likely the problem is in the heated hose. Either a connector has come loose or there is a broken wire. Because the gun whip takes the most abuse it is most likely that the whip has failed. Disconnect the crossover wires on the machine end of the whip hose and connect the two wires together coming off the 50' section, turn on the hose heat and see if the hose heat circuit is operating, if so replace the whip. To take a continuity reading through the heated hose one of the leads from the transformer to the "A" or "R" heated hose must be disconnected.

If no voltage is coming out of the transformer to the heated hose, move on to the next step.



PA-25/PAX-25 Manual

6. Open the console top and locate the solid state relay for the hose circuit, looking over the console top (front of machine) it is the relay to the right. With the hose turned on and there is a LED light lit on the relay take a volt meter that is set on AC volts and measure across position L1 and L2 (heavy wires). With the relay functioning properly you should have a 1 volt reading, if you have a higher volt reading (18-90) the relay has malfunctioned and needs to be replaced.

If there is no light on the solid state relay, move to the next step.

7. With a DC volt meter read across position A1 and A2 on the solid state relay (smaller wires) if you have a reading of 4-6 volts DC replace the solid state relay.

If there is no DC voltage to the relay, move to the next step.

8. Using a DC volt meter measure across position 9 and 10 on the back of the hose controller this is the output of the controller and sends power to the solid state relay, your reading will be **4-6 volts DC** if there is no reading check to make sure that the set temperature of the controller is above ambient temperature. Before replacing the controller read across position 1 and 2 to make sure that the controller is powered up, your reading will be 208 to 230 volts AC.

If no AC voltage is present, check for loose wires.

PROBLEM

Hose does not heat and the display on the controller shows an error message.

SOLUTIONS

1. Check position 6 and 7 on the heater controller for loose wires.

If the wires are tight, move to the next step.

2. Remove the transformer cover and check that the thermocouple wires are secure to the harness going up to the controller. If there are no loose connections disconnect the wire from the TSU and connect it directly to the thermocouple harness coming out of the hose transformer.

If the controller still shows the error code, replace the hose thermocouple.

If the error code goes away and temperature is now shown on the display of the controller, then all the TSU harnesses from the TSU to the transformer need to be checked for loose connectors or one or more of the harnesses are defective.



PA-25/PAX-25 Manual

PROBLEM

Heated hose controller shows excessive temperature.

SOLUTIONS

1. Set the controller set point at least 20 degrees lower than the temperature shown on the controller. Briefly turn on the hose and look for the LED light on the solid state relay to be on.

If the light is on replace the controller.

If the light is off replace the solid state relay.

PROBLEM

Hose will heat but does not come up to set temperature.

SOLUTIONS

1. Check the tap setting on the transformer to ensure that the correct position has been selected for the length of hose being used. Depending on the machines incoming voltage you may have to move the tap setting higher (up one).

CAUTION! Do not exceed the trip value of the transformer hose breaker.

WARNING! Before correcting any kind of defect, make sure the Main Power Switch is OFF and incoming power is locked OFF. NEVER access the inside of the Control Panel with the Proportioner power supply ON. The Pneumatic Unit is a component that works under pressure. Do not open any connection or carry out maintenance on components subject to pressure until all pressure has been bled to zero.



PA-25/PAX-25 Manual

PNEUMATIC DRIVE SYSTEM

PROBLEM

Pumps have stalled, the pressure on the chemical gauges are lower than normal.

SOLUTIONS

1. Check to see if the retract ball valve is in the open position.
2. Check the air supply to the machine, the 1/4" poly hose before the regulator must have 100 psi (6.9 bar) to maneuver the pilot valve. **If the air supply is at 100 psi (6.9 bar) move to the next step.**
3. Check that the solenoid has 24 volt DC, the valve as a normally closed valve and must be electrically activated to supply air to the air motor. **If the voltage is good move to the next step.**
4. Shut off power to the machine and the incoming air supply, remove the 1/2" poly tube from the outlet side of the solenoid valve. Turn on the power to the machine and the air supply. If no air is coming from the outlet side of the solenoid valve replace the valve. **If the valve is good move to the next step.**
5. Rebuild the pilot valve and or the air motor.

PROBLEM

Pumps have stalled, the pressure on the chemical gauge(s) are higher than normal.

NOTE! The power to the solenoid valve will be interrupted if one or both chemical pressures have exceeded the factory pressure setting of the high pressure shut off switches; this condition will shut off the air to the outlet side of the solenoid valve.

SOLUTIONS

1. If one of the chemical gauges reads high and the other low than you need to balance the pressures, open the manual valve on the side that has the higher reading. This will drop the pressure on the high side and bring up the pressure on the low side, when the pressures are within 200 psi (13.8 bar) of each other close the manual valve. If the problem continues refer to the troubleshooting section of the metering pump line or the spray gun manual. **If the pressure are not above the pressure switch settings go to the next step.**
2. Check that the wires attached to each pressure switch are secure. Remove the terminal lugs on the two high pressure shut off switches located on the top side of the preheater and take a continuity reading across the two terminals on the switch. If one of the switches is open the switch is defective or out of adjustment.



PA-25/PAX-25 Manual

WARNING! Before correcting any kind of defect, make sure the Main Power Switch is OFF and incoming power is locked OFF. NEVER access the inside of the Control Panel with the Proportioner power supply ON. The Pneumatic Unit is a component that works under pressure. Do not open any connection or carry out maintenance on components subject to pressure until all pressure has been bled to zero.



PA-25/PAX-25 Manual

METERING PUMP LINE

NOTE! Follow the recommended procedure in the indicated order to solve the problem and avoid unnecessary repairs. Make sure all Switches are in the correct position and Indicator Lights ON before determining the existence of a fault.

1. Safety Pressure Switch

Each Metering Pump has a Safety Pressure Switch set to 2,250 psi (155.1 bar) for size 1.23 pumps, 3200 (220.6 bar) psi for size 61 pumps. When the material system reaches this pressure, the Safety Pressure Switch will remove power from the Solenoid Valve and the incoming air supply will be cut off. A high pressure indicated on one or both of the material Pressure Gauges is an indication of an over-pressure condition. The Safety Pressure Switches are a momentary design; when the pressure bleeds off, the Metering Pump Line will resume normal operation. However, the cause of the over-pressure should be determined and corrected. The three most common causes are:

- a. Cavitation of the Metering Pump on the low pressure side causing high pressure on the opposite side.
- b. A restriction in the Spray Gun on the high pressure side.
- c. Air pressure set too high.

2. Pressure/Material Imbalance

In summary troubleshooting this problem requires the applicator to:

- a. Know what the NORMAL spray pressures are for the application in progress.
- b. Determine what material is NOT exiting the Mixing Chamber.
- c. Read the Pressure Gauge on the problem side and interpret the reading.

| MATERIAL CONDITION | “A” GAUGE | “R” GAUGE |
|-------------------------|-----------|-----------|
| NORMAL | | |
| LACK OF ISO (A) | | |
| LACK OF POLY (R) | | |
| RESTRICTION OF ISO (A) | | |
| RESTRICTION OF POLY (R) | | |



PA-25/PAX-25 Manual

3. Cavitation

Cavitation occurs when the Metering Pump requires a larger volume of material than the supply system (Transfer Pump) can furnish. This creates a “void” of material in the Metering Pump. The most common causes of cavitation are:

- a. Material temperature is too low causing increased material viscosity resulting in the inability of the Transfer Pump to maintain sufficient supply to the Metering Pump. This is most common with today’s 245fa blown systems. Ensure the material temperature in the drums is no lower than the material suppliers’ recommendation.
- b. Failure to vent the material drum while drawing material out with the Transfer Pump causes a vacuum and cavitation in the Transfer Pump. Ensure the drum is vented to the atmosphere or a Desiccated Air Dryer Kit is installed as recommended by the material supplier.
- c. Air volume insufficient for Transfer Pump or Transfer Pump Air Valve partially closed will limit the ability of the Transfer Pump to operate at its maximum capability.
- d. Inlet Material Screen obstructed (See MAINTENANCE section).
- e. Metering Pump Inlet Ball does not seat properly allowing material to flow back into the Material Delivery Hose when the Metering Pump is on the “Discharge” stroke. This causes the volume of material on that Metering Pump to be less on the discharge stroke resulting in intermittent off-ratio material and Pressure Gauge fluctuation.

4. Pressure Loss: Discharge/Inlet Ball

Observation of the material Pressure Gauges and the direction the pumps are moving is necessary to determine which direction the Metering Pump fails to maintain pressure. Refer to the chart to determine problem:

| | Pump on the down stroke | Pump on the up stroke |
|---------------------------|--|---|
| Iso Pressure Gauge FALLS | Iso Inlet Ball does not seat properly | Iso Discharge Ball does not seat properly |
| Poly Pressure Gauge FALLS | Poly Discharge Ball does not seat properly | Poly Inlet Ball does not seat properly |

In most cases the cause of a leaking Inlet/Discharge Ball is foreign material preventing the Ball from seating properly. If the above steps do not resolve the problem, replace the appropriate Ball, Ball Seat and Ball Seat Gasket.



PA-25/PAX-25 Manual

MAINTENANCE

NOTE! To achieve maximum output from the Classic PA Series Proportioner, a daily or regular maintenance schedule is required.

INLET MATERIAL SCREENS

Inspection of the Inlet Material Screens on a daily basis is no longer necessary as long as the following conditions are met.

- Material drums are stored within the recommended material storage temperature range and drums are not opened prior to installing the Proportioner Material Transfer Drum Pumps.
- Desiccated air dryers are used to dry replacement air as material is removed from the drums to the Proportioner.
- Consolidation of old material into a common drum for use is minimized especially the Iso "A".

If the above conditions are met, inspection of the Inlet Material Screens may be done on a **bi-weekly** basis.

NOTE! Inspect and clean Inlet Material Screens before Proportioner start-up. They should not be cleaned after the day's operation as the Proportioner should be purged immediately after inspection and cleaning. This is to reduce the risk of moisture contamination, contamination through the reaction with the solvent used in the cleaning operation and cross-over at the Spray Gun due to air entrapment.

To check the Inlet Material Screens, proceed as follows:

CAUTION! Make sure the Main Power Switch is OFF and incoming power is locked OFF.

1. CLOSE the Poly "R" Proportioner Inlet Valve.
2. Place a suitable container under the Material Inlet Strainer to collect the residual material. Carefully loosen the Strainer Plug allowing the material to drain into the container.
3. Completely unscrew the Strainer Screw.
4. Remove the Seal, Spring and Screen and clean them with a suitable solvent. Dry the parts and ensure the Screen is not obstructed. Replace the Screen if more than 20% of the Screen surface is obstructed by residue.

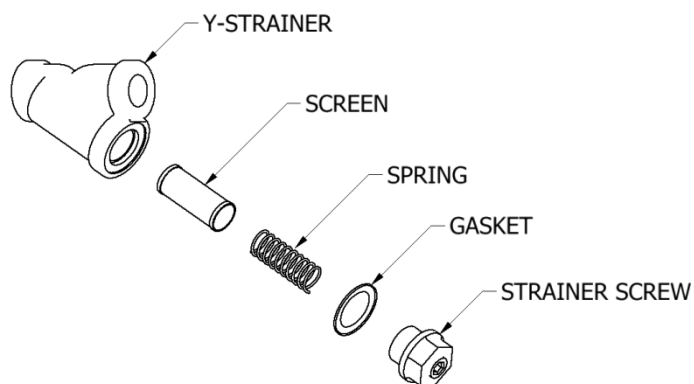



PA-25/PAX-25 Manual

5. Reinstall the Screen, Spring and Seal. Screw on the Strainer Screw and screw in Plug.
6. OPEN the Poly "R" Proportioner Inlet Valve, pressurize the Material Transfer Pump, check for leaks.
7. Repeat above for the Iso "A" side.
8. Proceed with Proportioner Purging operation (page 18).



PA-25/PAX-25 Manual

METERING PUMP LINE

WARNING! Before performing any maintenance, make sure the Main Power Switch is OFF and incoming power is locked OFF. Allow material temperature to cool below 80°F and bleed all material pressure to zero.

Weekly: When the Proportioning Pumps are functioning properly it is not unusual to a small amount of material to appear on the Pump Shaft. This material should be wiped away so dirt does not accumulate on the Pump Shaft and the Pump Shaft Packings are not damaged.

Yearly or as required: Assuming the Iso (A) and Poly (R) is free from contaminants, the maintenance of the Iso Reservoir cup is performed, and the maintenance of the Pump Shafts (above) is followed, the Proportioning Pumps will perform for many maintenance free cycles. However, it is not unusually for those who use the PA Series Proportioner on a regular basis to rebuild the Proportioning Pumps on a yearly basis.



Pump Disassembly and Seal Replacement

Refer to Parts Identification Drawing for reference.



PA-25/PAX-25 Manual

MATERIAL HEATER

WARNING! Before performing any maintenance, make sure the Main Power Switch is OFF and incoming power is locked OFF. NEVER access the inside of the Control Panel with the Proportioner power supply ON. The Heaters are components that reach high temperatures; you must wait until they have cooled before handling and bleed all material pressure to zero.



Thermocouple Replacement

NOTE! The Thermocouple is assembled into the Connector Body with a Ferrule and Nut. Once inserted into the Body and the Nut is tightened, the Ferrule locks to the Thermocouple and does not allow it to be relocated or moved. The location of the Thermocouple is very important and must be done correctly before tightening the Nut.

1. Unscrew the Nut that holds the defective Thermocouple and remove from the Body. Disconnect Thermocouple wiring located under the Top Cover of the Heater. Remove Body and discard.
2. Install Connector Body into Heater using an open-end wrench and tighten to prevent leakage. Teflon Tape or appropriate Thread Sealant should be used.
3. Slide the Nut and the Ferrule over the Thermocouple and insert this assembly into the Connector Body until it comes into positive physical contact with the Heating Rod. Make sure the Spring does not prevent the Thermocouple from making contact with the Heating Rod.
4. Slowly tighten the Nut using an open-end wrench, ensuring the Thermocouple maintains positive physical contact with the Heating Rod.
5. Reinstall the Thermocouple wires.

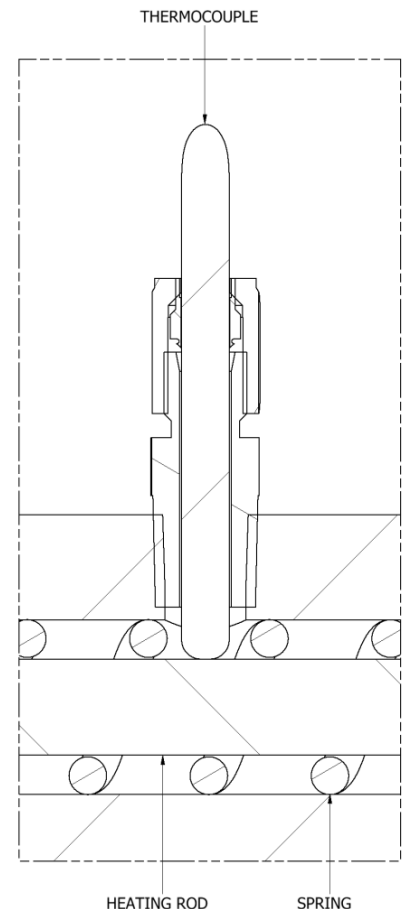
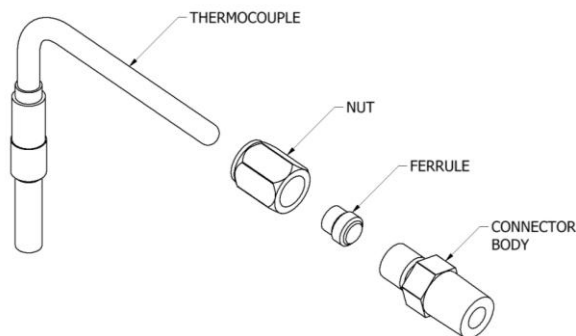



PA-25/PAX-25 Manual

WARNING! Before performing any maintenance, make sure the Main Power Switch is OFF and incoming power is locked OFF. NEVER access the inside of the Control Panel with the Proportioner power supply ON. The Heaters are components that reach high temperatures; you must wait until they have cooled before handling and bleed all material pressure to zero.



Heating Rod

To replace a defective Heating Rod proceed as follows:

1. Ensure Main Power Switch is OFF and incoming power is locked OFF. Depressurize proportioner and, remove the Heater Cover.

WARNING! If the Heating Rod to be replaced is the one in contact with the Thermocouple, it is necessary to remove the Thermocouple first. Do not loosen or tighten Thermocouple Body.

2. Disconnect the suspect Heating Rod from the wire connections and test Heating Rod again for proper electrical resistance. 1250 W Heating Rod is 39 ohms.
3. Unscrew the Heating Rod and remove from the Heater Block along with its Spring and inspect; it must be smooth and shiny in appearance. If it is blackened or has material adhered to it replace the Heating Rod even if ohm reading is acceptable.
4. Apply Teflon Tape or appropriate Thread Sealant to the Heating Rod thread and assemble Heating Rod and Spring into the Heater Block.

Tighten securely to 110 ft-lbs (149 N-m).

5. If necessary carefully re-install Thermocouple ensuring positive physical contact with the Heating Rod. Make sure the Spring does not prevent the Thermocouple from making contact with the Heating Rod. Tighten Nut with open-end wrench.
6. Reconnect wire connections and reinstall the Cover.
7. Ensure Heater is full of material prior to electrical testing.



PA-25/PAX-25 Manual

REPLACEMENT PARTS

PA/PAX AIR MOTOR ASSEMBLY

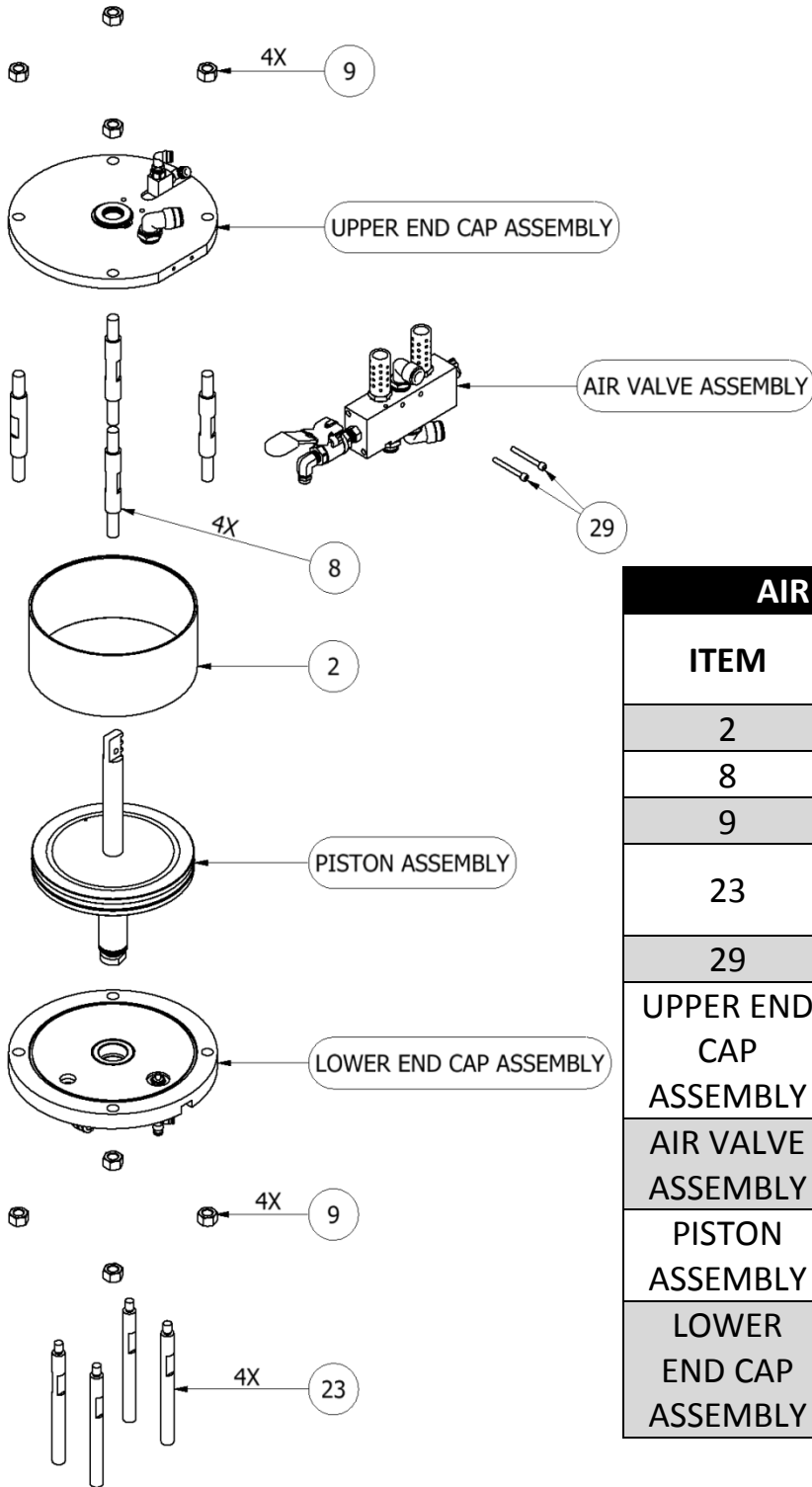

| AIR MOTOR ASSEMBLY (PA-001) | | | |
|-----------------------------|-----|-------------|---------------|
| ITEM | QTY | PART NUMBER | DESCRIPTION |
| 2 | 1 | PA-007 | CYLINDER |
| 8 | 4 | PA-013 | TIE ROD |
| 9 | 8 | PA-014 | NUT |
| 23 | 4 | PA-030 | LOWER TIE ROD |
| 29 | 2 | PA-021 | CAP SCREW |
| UPPER END CAP ASSEMBLY | 1 | - | SEE PAGE 41 |
| AIR VALVE ASSEMBLY | 1 | - | SEE PAGE 42 |
| PISTON ASSEMBLY | 1 | - | SEE PAGE 43 |
| LOWER END CAP ASSEMBLY | 1 | - | SEE PAGE 44 |



PA-25/PAX-25 Manual

UPPER END CAP ASSEMBLY

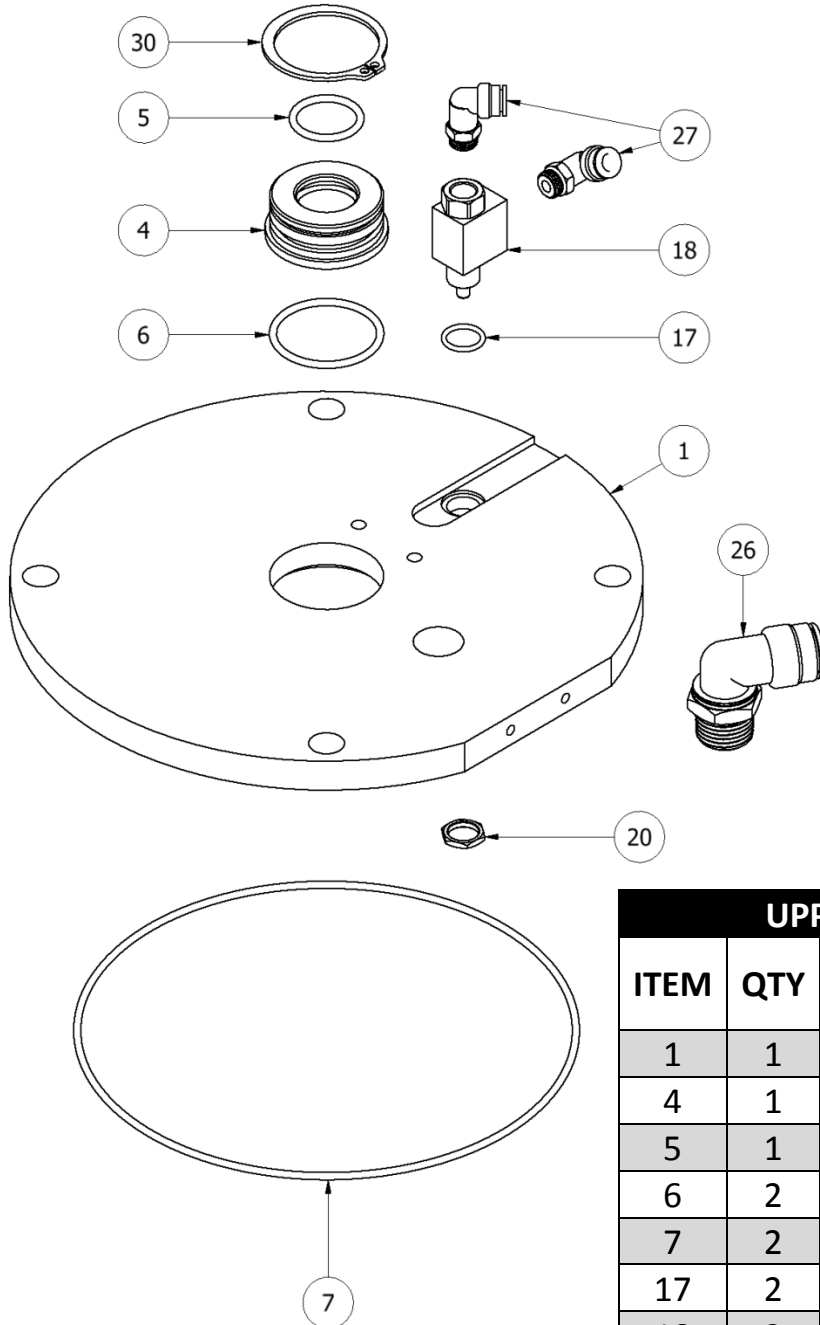

| UPPER END CAP ASSEMBLY | | | |
|------------------------|-----|-------------|-------------------|
| ITEM | QTY | PART NUMBER | DESCRIPTION |
| 1 | 1 | PA-002 | UPPER END CAP |
| 4 | 1 | PA-003 | UPPER BUSHING |
| 5 | 1 | OR-118 | O-RING |
| 6 | 2 | OR-127 | O-RING |
| 7 | 2 | OR-167 | O-RING |
| 17 | 2 | OR-014 | O-RING |
| 18 | 2 | PA-004 | 3-WAY VALVE |
| 20 | 1 | PA-031 | SPACER NUT |
| 26 | 3 | PA-006 | 1/2" SWIVEL ELBOW |
| 27 | 3 | PA-017 | MALE ELBOW |
| 30 | 2 | PA-012 | SNAP RING |



PA-25/PAX-25 Manual

AIR VALVE ASSEMBLY

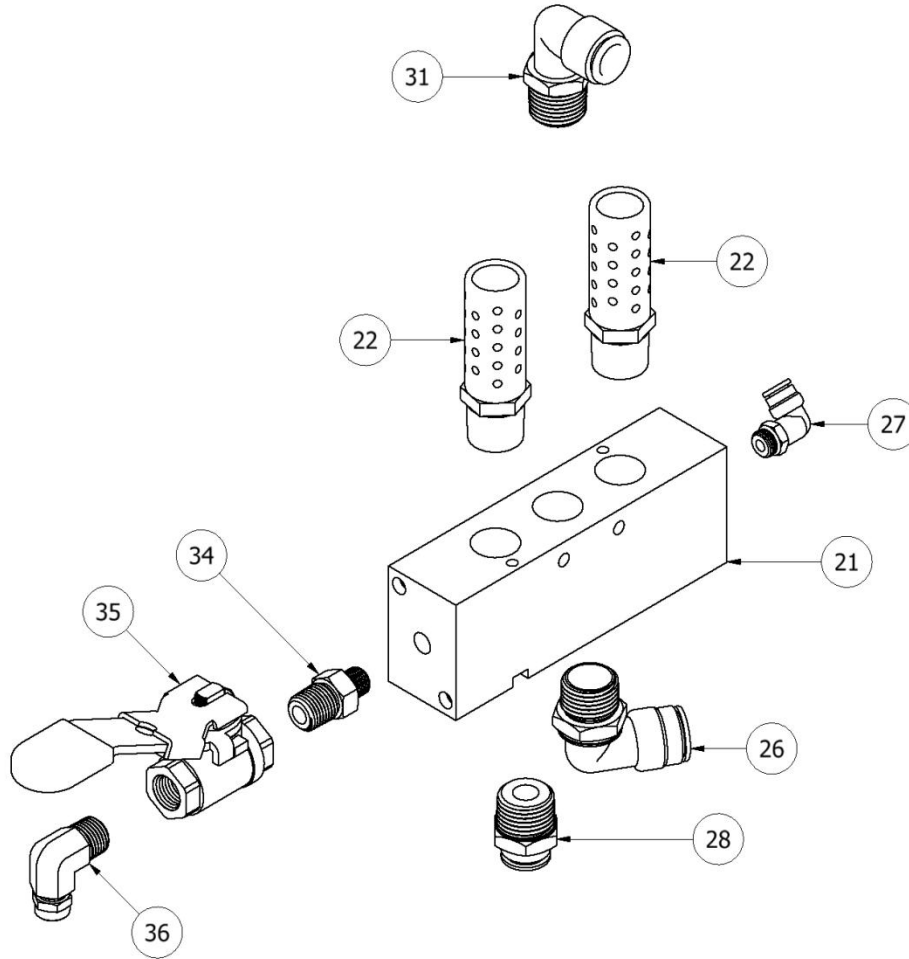

| AIR VALVE ASSEMBLY | | | |
|--------------------|-----|-------------|-------------------------------|
| ITEM | QTY | PART NUMBER | DESCRIPTION |
| 21 | 1 | PA-005 | 5-WAY VALVE |
| 22 | 2 | PA-019 | MUFFLER |
| 26 | 3 | PA-006 | 1/2" SWIVEL ELBOW |
| 27 | 3 | PA-017 | MALE ELBOW |
| 28 | 1 | PA-23 | MALE CONNECTOR |
| 31 | 1 | NE-06012 | QUICK LOCK TUBE FITTING |
| 34 | 1 | HI-05095 | 1/4 X 1/8 HEX NIPPLE |
| 35 | 1 | HI-00068 | VALVE; RETRACT A SIDE |
| 36 | 1 | AD-09 | 1/4 NPT X 1/4 TUBE FITTING 90 |



PA-25/PAX-25 Manual

PISTON ASSEMBLY

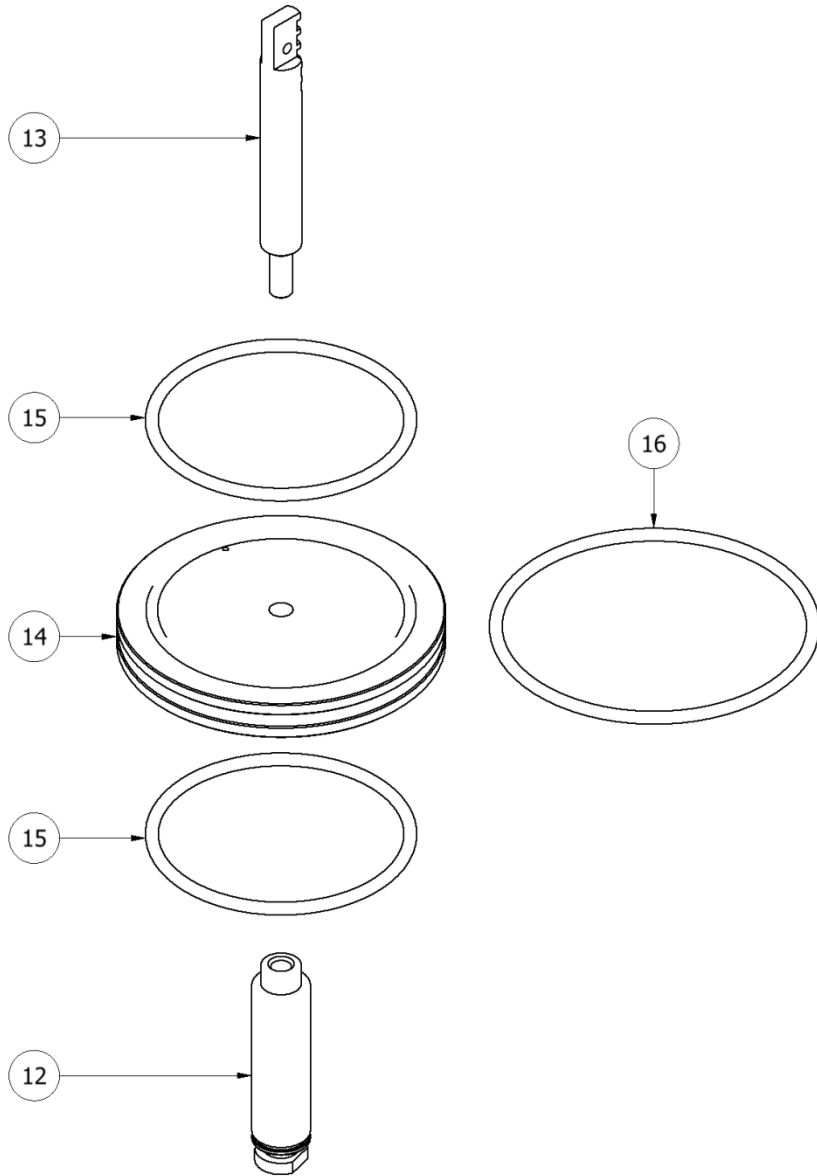

| PISTON ASSEMBLY | | | |
|-----------------|-----|-------------|--------------------|
| ITEM | QTY | PART NUMBER | DESCRIPTION |
| 12 | 1 | PA-009 | LOWER ROD |
| 13 | 1 | PA-29 | UPPER ROD ASSEMBLY |
| 14 | 1 | PA-008 | PISTON; 7" |
| 15 | 2 | OR-431 | O-RING |
| 16 | 1 | OR-439 | O-RING |



PA-25/PAX-25 Manual

LOWER END CAP ASSEMBLY

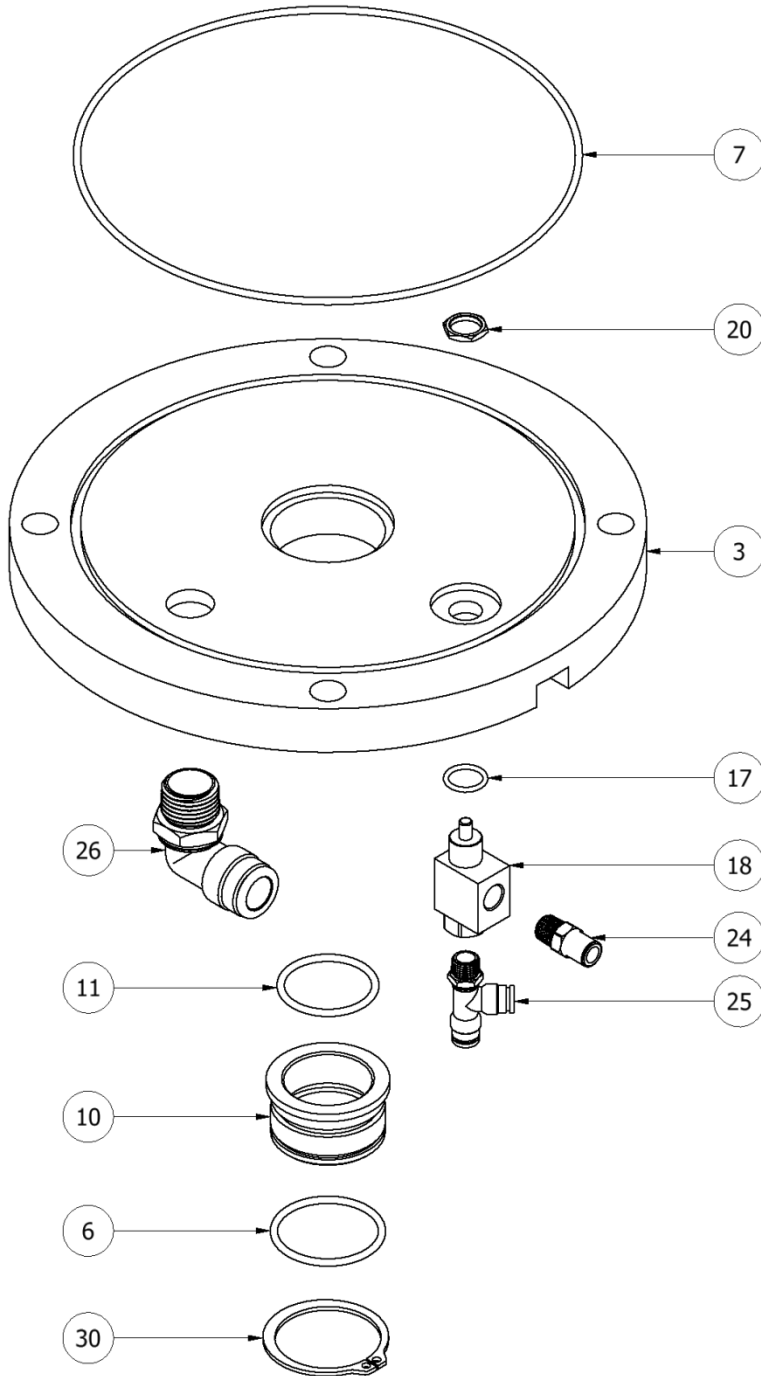

| LOWER END CAP ASSEMBLY | | | |
|------------------------|-----|-------------|-------------------|
| ITEM | QTY | PART NUMBER | DESCRIPTION |
| 3 | 1 | PA-010 | LOWER END CAP |
| 6 | 2 | OR-127 | O-RING |
| 7 | 2 | OR-167 | O-RING |
| 10 | 1 | PA-011 | LOWER BUSHING |
| 11 | 1 | OR-124 | O-RING |
| 17 | 2 | OR-014 | O-RING |
| 18 | 2 | PA-004 | 3-WAY VALVE |
| 20 | 1 | PA-031 | SPACER NUT |
| 24 | 1 | PA-020 | MALE CONNECTOR |
| 25 | 1 | PA-027 | TUBE FITTING |
| 26 | 3 | PA-006 | 1/2" SWIVEL ELBOW |
| 30 | 2 | PA-012 | SNAP RING |



PA-25/PAX-25 Manual

PA (A & R) SINGLE PUMP ASSEMBLY (16:1)

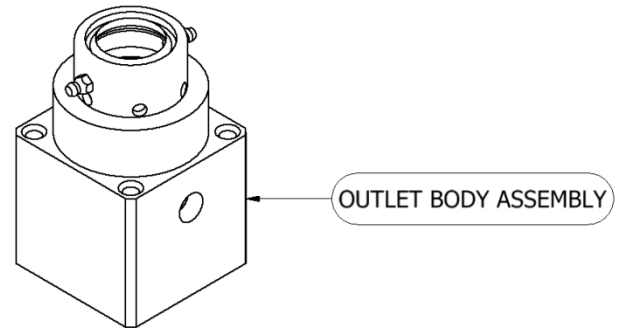

| PA (A & R) SINGLE PUMP ASSEMBLY (PA-044) | | | |
|--|-----|-------------|-------------|
| ITEM | QTY | PART NUMBER | DESCRIPTION |
| 24 | 4 | PA-057 | CAP SCREW |
| OUTLET BODY ASSEMBLY | 1 | - | SEE PAGE 46 |
| PISTON ASSEMBLY | 1 | - | SEE PAGE 47 |
| INLET BODY ASSEMBLY | 1 | - | SEE PAGE 48 |

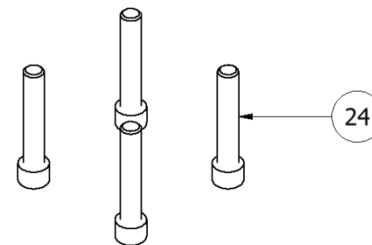
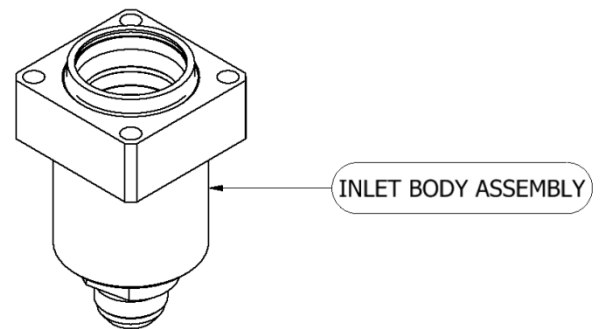



PA-25/PAX-25 Manual

PA OUTLET BODY ASSEMBLY

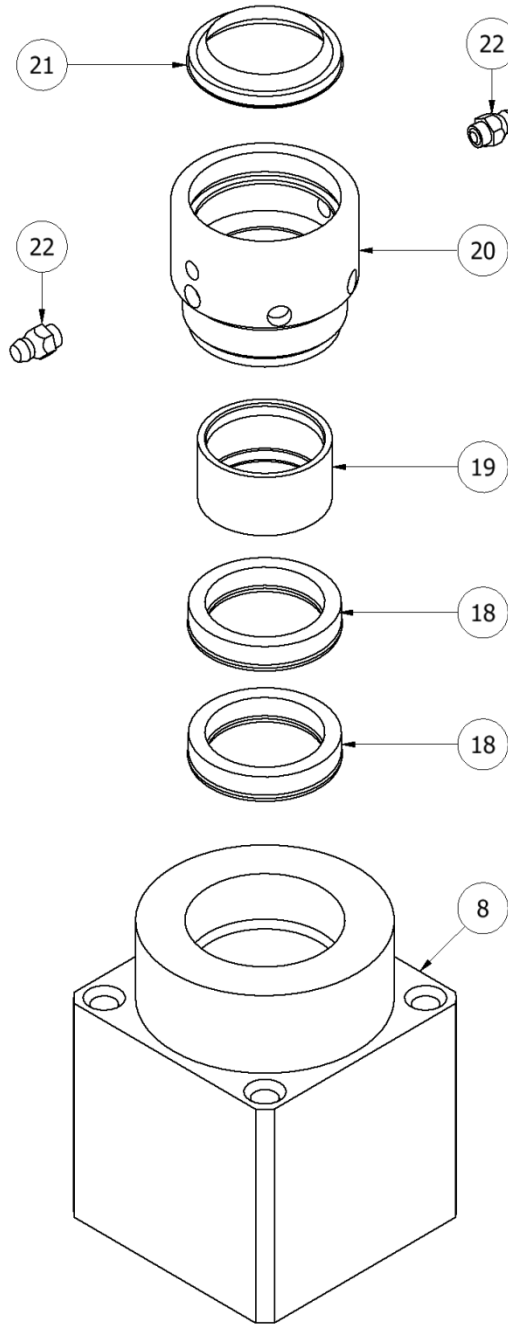

| OUTLET BODY ASSEMBLY | | | |
|----------------------|-----|-------------|-------------------|
| ITEM | QTY | PART NUMBER | DESCRIPTION |
| 8 | 1 | PA-045 | OUTLET BODY |
| 18 | 2 | PA-052 | ROD SEAL ASSEMBLY |
| 19 | 1 | PA-051 | ROD BUSHING |
| 20 | 1 | PA-064 | PACKING NUT |
| 21 | 1 | PA-065 | SCRAPER SEAL |
| 22 | 2 | PA-066 | GREASE FITTING |



PA-25/PAX-25 Manual

PA PISTON ASSEMBLY

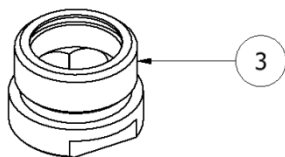
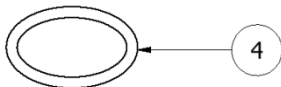
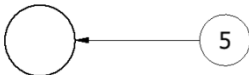
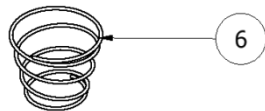
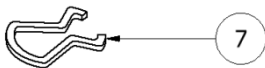
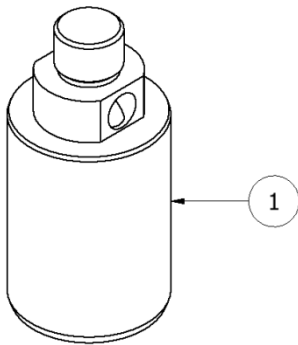
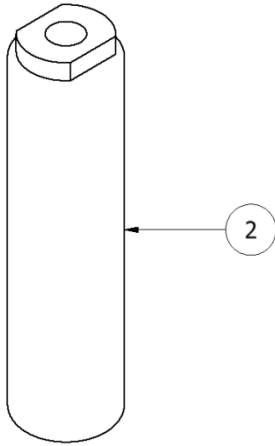

| PISTON ASSEMBLY | | | |
|-----------------|-----|-------------|------------------|
| ITEM | QTY | PART NUMBER | DESCRIPTION |
| 1 | 1 | PA-047 | PISTON |
| 2 | 1 | PA-062 | FLUID ROD |
| 3 | 1 | PA-046 | PISTON VALVE |
| 4 | 1 | OR-916 | O-RING |
| 5 | 1 | PA-048 | 3/4" CHROME BALL |
| 6 | 1 | PA-049 | SPRING |
| 7 | 1 | PA-050 | SPRING RETAINER |



PA-25/PAX-25 Manual

PA INLET BODY ASSEMBLY

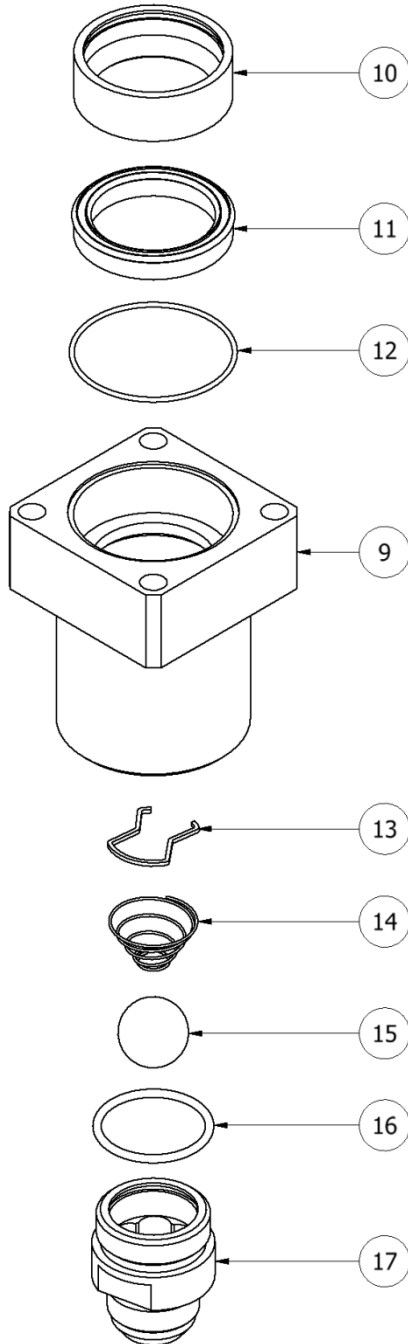

| INLET BODY ASSEMBLY | | | |
|---------------------|-----|-------------|----------------------|
| ITEM | QTY | PART NUMBER | DESCRIPTION |
| 9 | 1 | PA-053 | INLET BODY |
| 10 | 1 | PA-055 | PISTON BUSHING |
| 11 | 1 | PA-054 | PISTON SEAL ASSEMBLY |
| 12 | 1 | OR-035 | O-RING |
| 13 | 1 | PA-060 | BALL STOP |
| 14 | 1 | PA-061 | FOOT VALVE SPRING |
| 15 | 1 | PA-059 | 1" BALL |
| 16 | 1 | OR-920 | O-RING |
| 17 | 1 | PA-058 | INLET VALVE |



PA-25/PAX-25 Manual

PA FLUID SECTION ASSEMBLY (16:1)

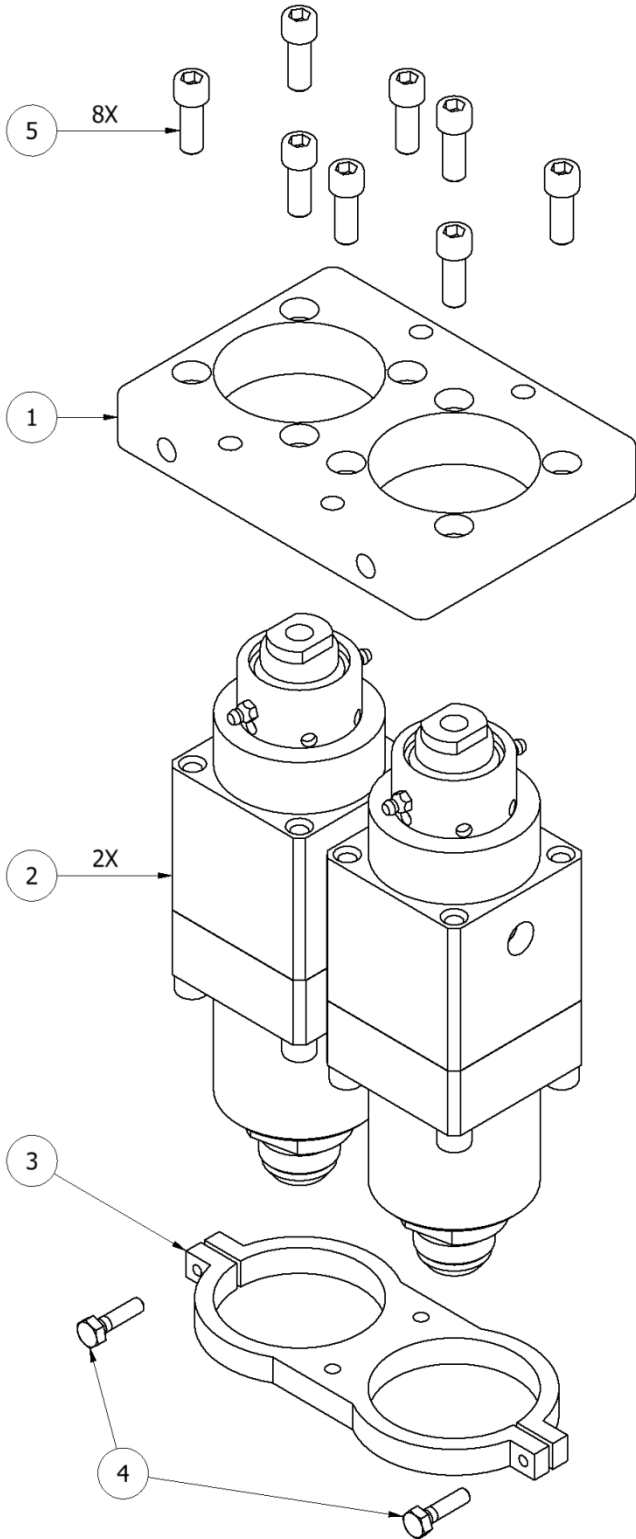

| FLUID SECTION ASSEMBLY (PL-PA) | | | |
|--------------------------------|-----|-------------|---------------------------------|
| ITEM | QTY | PART NUMBER | DESCRIPTION |
| 1 | 1 | PA-069 | TRANSITION PLATE |
| 2 | 2 | PA-044 | PA (A & R) SINGLE PUMP ASSEMBLY |
| 3 | 1 | PA-070 | STABILIZER CLAMP |
| 4 | 2 | PA-067 | HEX BOLT |
| 5 | 8 | PA-056 | CAP SCREW |



PA-25/PAX-25 Manual

PA PUMP LINE ASSEMBLY

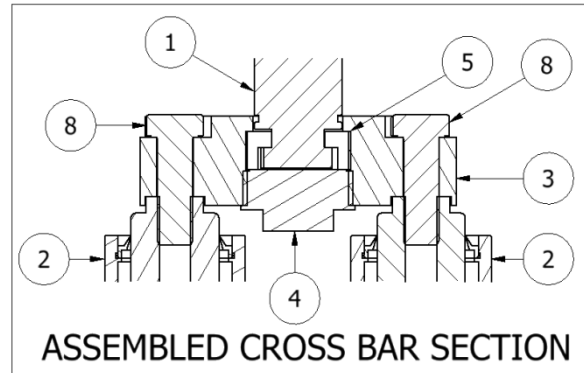
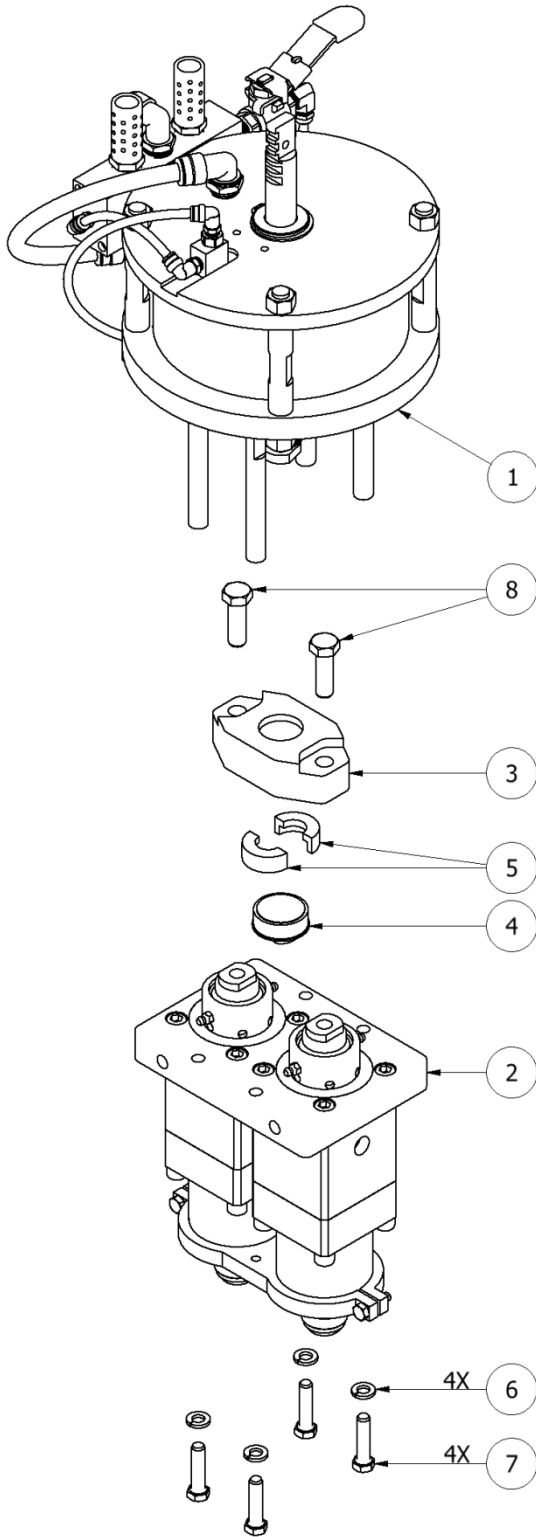

| PA PUMP LINE ASSEMBLY (PL-6) | | | |
|------------------------------|-----|-------------|----------------------|
| ITEM | QTY | PART NUMBER | DESCRIPTION |
| 1 | 1 | PA-001 | AIR MOTOR ASSEMBLY |
| 2 | 1 | PL-PA | FLUID SECTION (16:1) |
| 3 | 1 | PA-072 | CROSS BAR |
| 4 | 1 | PA-073 | SHELL PLUG |
| 5 | 2 | PA-071 | HALF SHELL |
| 6 | 4 | PA-015 | LOCK WASHER |
| 7 | 4 | PA-016 | HEX BOLT |
| 8 | 2 | PA-063 | BOLT |



PA-25/PAX-25 Manual

PAX (A&R) SINGLE PUMP ASSEMBLY (30:1)

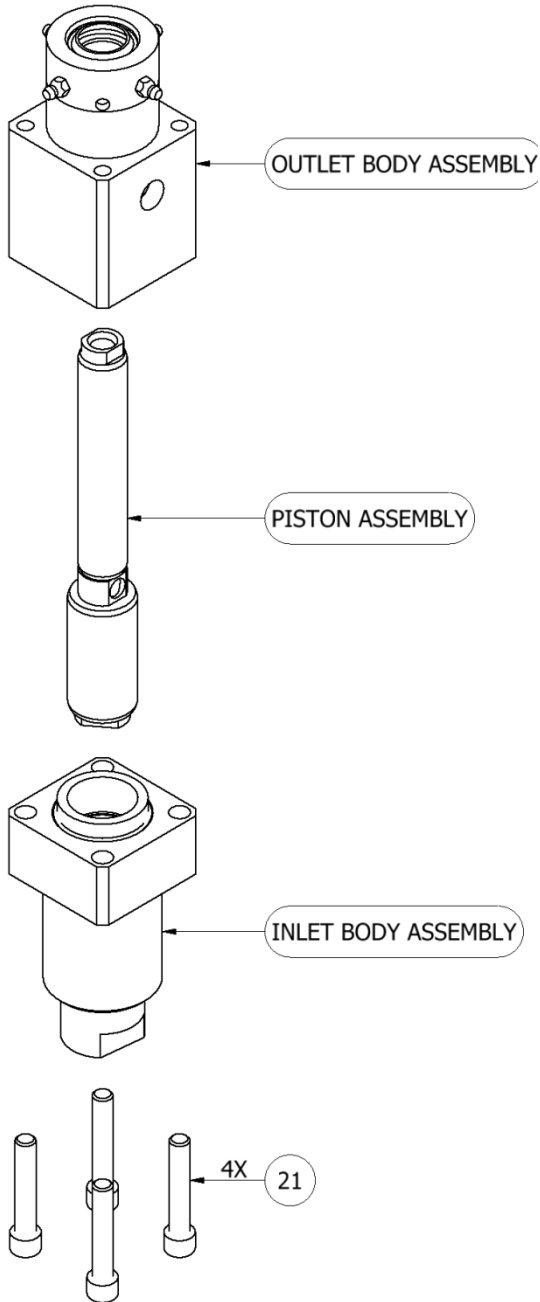

| PAX (A & R) SINGLE PUMP ASSEMBLY (PAX-044) | | | |
|---|------------|--------------------|--------------------|
| ITEM | QTY | PART NUMBER | DESCRIPTION |
| 24 | 4 | PA-057 | CAP SCREW |
| OUTLET BODY ASSEMBLY | 1 | - | SEE PAGE 52 |
| PISTON ASSEMBLY | 1 | - | SEE PAGE 53 |
| INLET BODY ASSEMBLY | 1 | - | SEE PAGE 54 |



PA-25/PAX-25 Manual

PAX OUTLET BODY ASSEMBLY

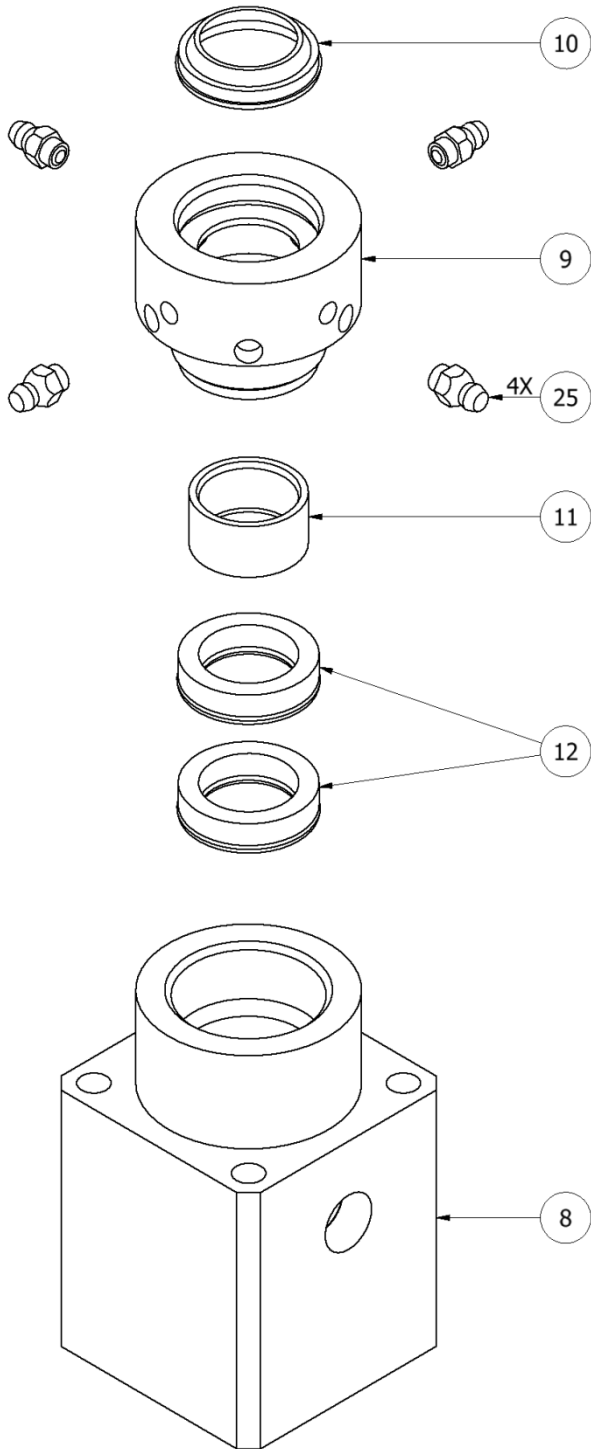

| OUTLET BODY ASSEMBLY | | | |
|----------------------|-----|-------------|-------------------|
| ITEM | QTY | PART NUMBER | DESCRIPTION |
| 8 | 1 | PAX-045 | OUTLET BODY |
| 9 | 1 | PAX-064 | PACKING NUT |
| 10 | 1 | PAX-065 | SCRAPER SEAL |
| 11 | 1 | PAX-051 | ROD BUSHING |
| 12 | 2 | PAX-052 | ROD SEAL ASSEMBLY |
| 25 | 4 | PA-066 | GREASE FITTING |



PA-25/PAX-25 Manual

PAX PISTON ASSEMBLY

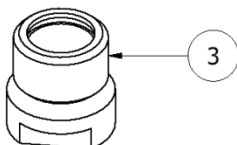
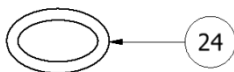
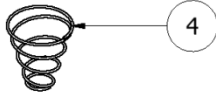
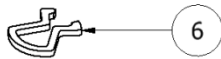
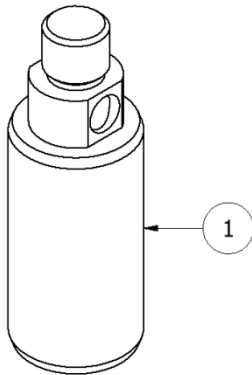
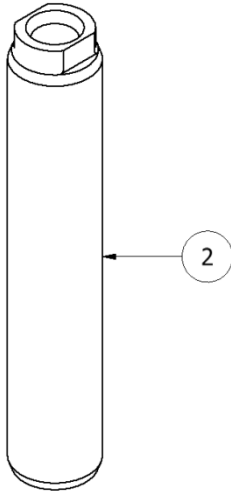

| PISTON ASSEMBLY | | | |
|-----------------|-----|-------------|-----------------|
| ITEM | QTY | PART NUMBER | DESCRIPTION |
| 1 | 1 | PAX-047 | PISTON |
| 2 | 1 | PAX-062 | FLUID ROD |
| 3 | 1 | PAX-046 | PISTON VALVE |
| 4 | 1 | PAX-049 | SPRING |
| 5 | 1 | PAX-059 | 1/2" BALL |
| 6 | 1 | PAX-050 | SPRING RETAINER |
| 24 | 1 | OR-116 | O-RING |



PA-25/PAX-25 Manual

PAX INLET BODY ASSEMBLY

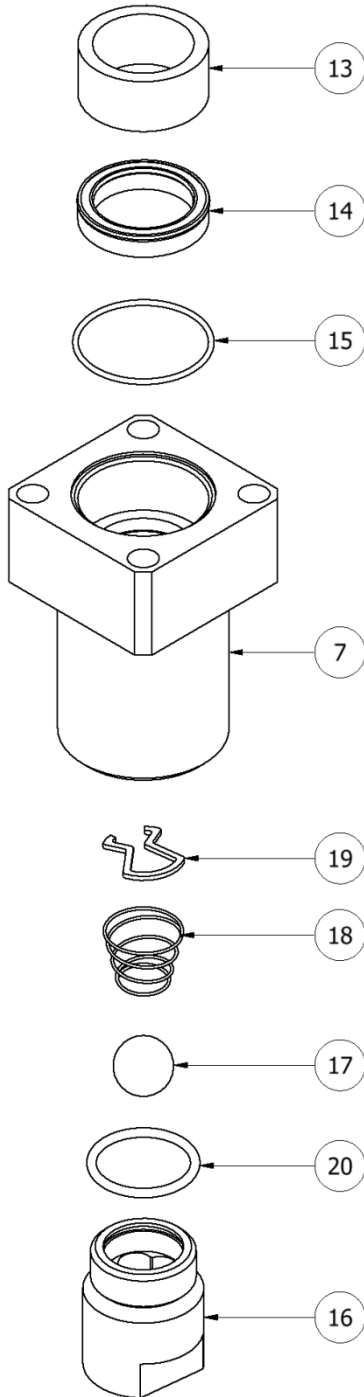

| INLET BODY ASSEMBLY | | | |
|---------------------|-----|-------------|--------------------|
| ITEM | QTY | PART NUMBER | DESCRIPTION |
| 7 | 1 | PAX-053 | INLET BODY |
| 13 | 1 | PAX-055 | PISTON BUSHING |
| 14 | 1 | PA-052 | ROD SEAL ASSEMBLY |
| 15 | 1 | OR-030 | O-RING |
| 16 | 1 | PAX-058 | INLET VALVE |
| 17 | 1 | PA-048 | 3/4" BALL |
| 18 | 1 | PAX-061 | SPRING; FOOT VALVE |
| 19 | 1 | PA-050 | SPRING RETAINER |
| 20 | 1 | OR-916 | O-RING |



PA-25/PAX-25 Manual

FLUID SECTION (PL-PAX)

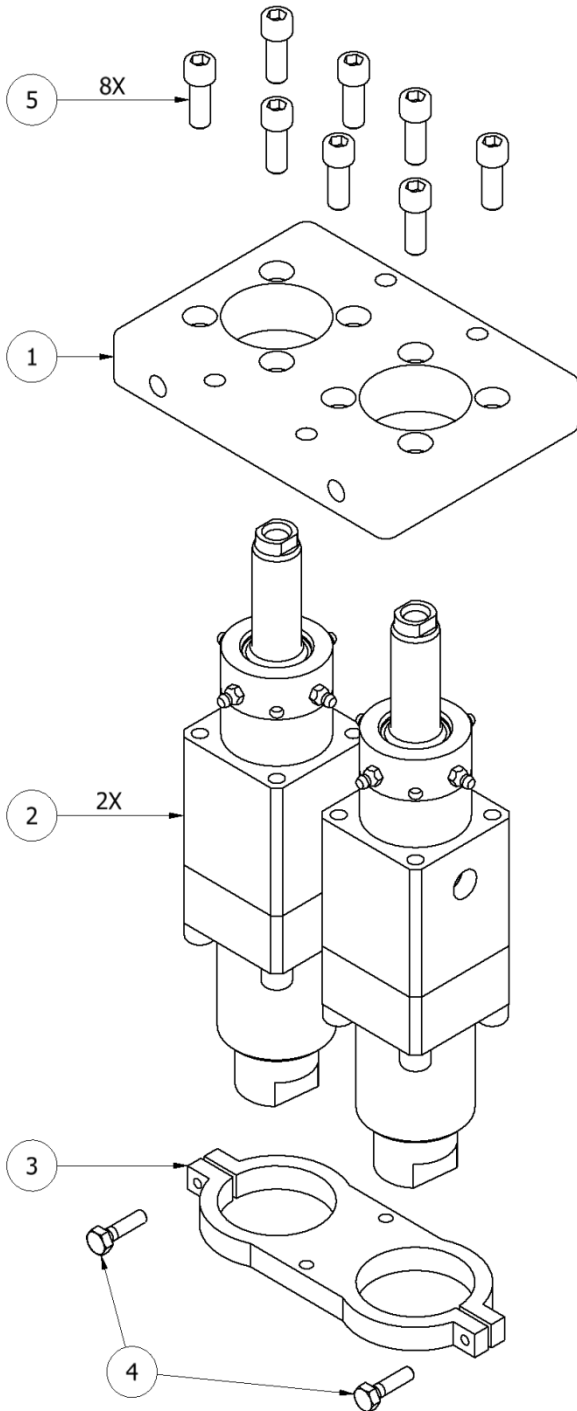

| FLUID SECTION (PL-PAX) | | | |
|------------------------|-----|-------------|---|
| ITEM | QTY | PART NUMBER | DESCRIPTION |
| 1 | 1 | PAX-069 | TRANSITION PLATE |
| 2 | 2 | PAX-044 | PAX (A & R) SINGLE PUMP ASSEMBLY (30:1) |
| 3 | 1 | PAX-070 | STABILIZER CLAMP |
| 4 | 2 | PA-067 | HEX BOLT |
| 5 | 8 | PA-056 | CAP SCREW |



PA-25/PAX-25 Manual

PAX PUMP LINE ASSEMBLY (PL-7)

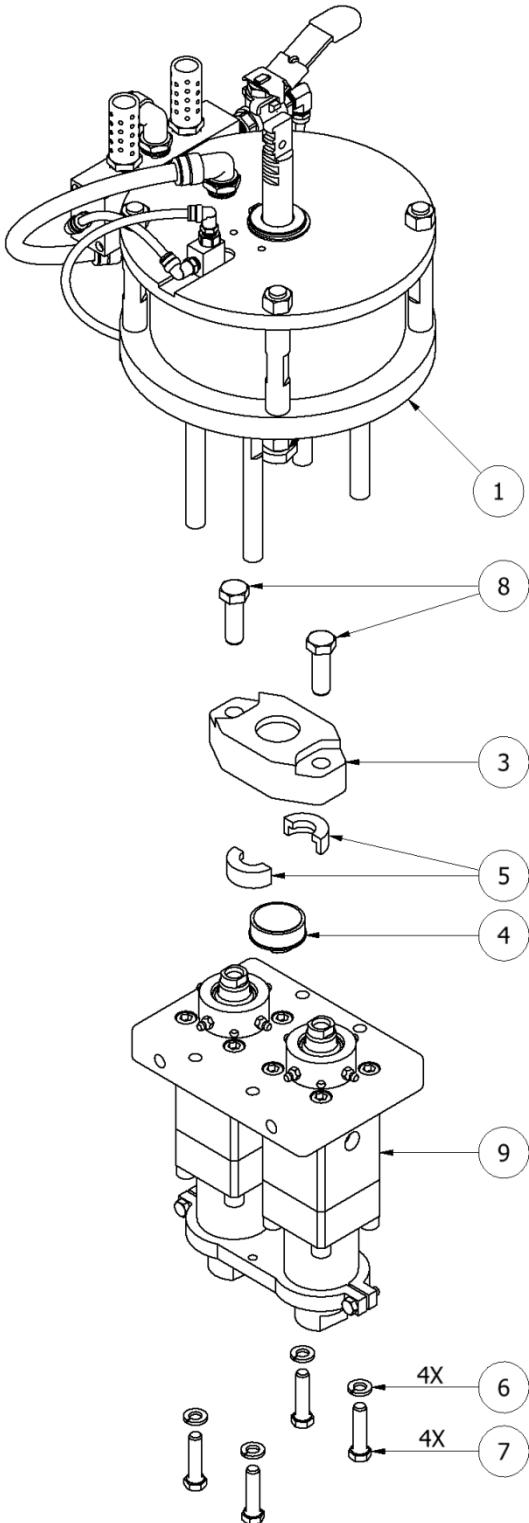

| PAX PUMP LINE ASSEMBLY (PL-7) | | | |
|-------------------------------|-----|-------------|----------------------------------|
| ITEM | QTY | PART NUMBER | DESCRIPTION |
| 1 | 1 | PA-001 | AIR MOTOR ASSEMBLY |
| 2 | 1 | PAX-044 | PAX (A & R) SINGLE PUMP ASSEMBLY |
| 3 | 1 | PAX-072 | CROSS BAR |
| 4 | 1 | PA-073 | SHELL PLUG |
| 5 | 2 | PA-071 | HALF SHELL |
| 6 | 4 | PA-015 | LOCK WASHER |
| 7 | 4 | PA-016 | HEX BOLT |
| 8 | 2 | PA-063 | BOLT |



PA-25/PAX-25 Manual

HEATER ASSEMBLY

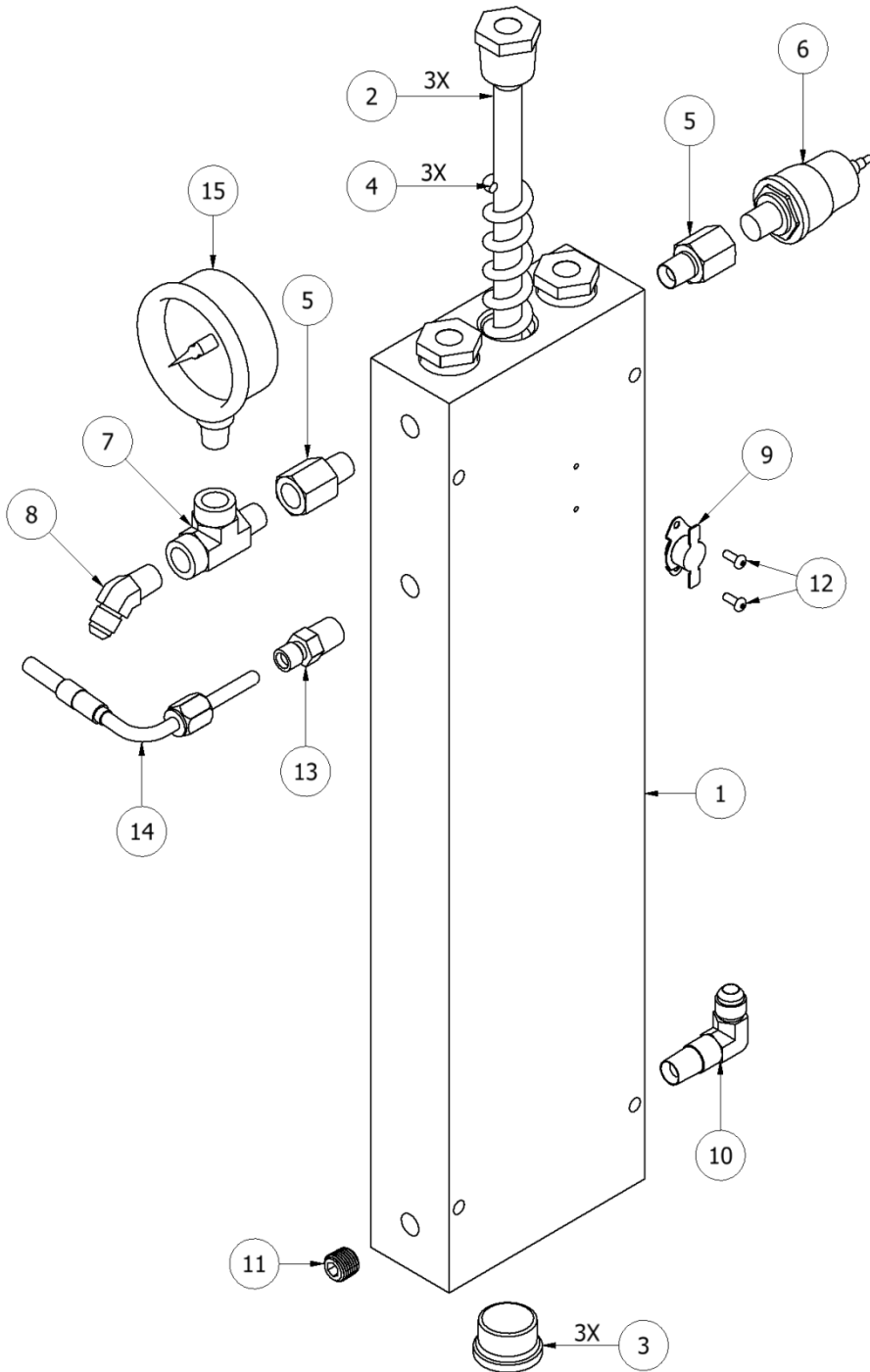

| HEATER (PH-16 & PH-17) | | | |
|------------------------|-----|---------------|----------------------------------|
| ITEM | QTY | PART NUMBER | DESCRIPTION |
| 1 | 1 | GM-06424-1 | HEATER BODY |
| 2 | 3 | GM-05423-1250 | HEATER CARTRIGE |
| 3 | 3 | HI-05034 | O-RING PLUG |
| 4 | 3 | GM-05423-7 | SPRING |
| 5 | 2 | HI-05088 | FITTING, NPT 1/4 M X 1/4 F |
| 6 | 1 | EL-52-2200 | PRESSURE SWITCH (PA) |
| | | EL-52-3200 | PRESSURE SWITCH (PAX) |
| 7 | 1 | GP-00100-3 | MALE RUN TEE X FEMALE PIPE 1/4 |
| 8 | 1 | HI-05026 | OUTLET HEATER FITTING (PH-17) |
| | | HI-05027 | OUTLET HEATER FITTING (PH-16) |
| 9 | 1 | EL-00006A | SWITCH; THERMAL LIMIT OVERTEMP |
| 10 | 1 | HI-05059 | 1/4 X #6 JIC ADAPTER |
| 11 | 1 | HI-05036 | 1/4 NPT FLUSH SEAL PIPE PLUG |
| 12 | 2 | - | 6-32 X 3/8" BUTTON SHCS |
| 13 | 1 | HI-05020 | THERMOCOUPLE NUT |
| 14 | 1 | HI-05021 | THERMOCOUPLE; TYPE E |
| 15 | 1 | HI-05028 | PRESSURE GAUGE, 0-3000 PSI (PA) |
| | | HI-00035 | PRESSURE GAUGE, 0-5000 PSI (PAX) |



PA-25/PAX-25 Manual

HEATER ASSEMBLY

PH-16

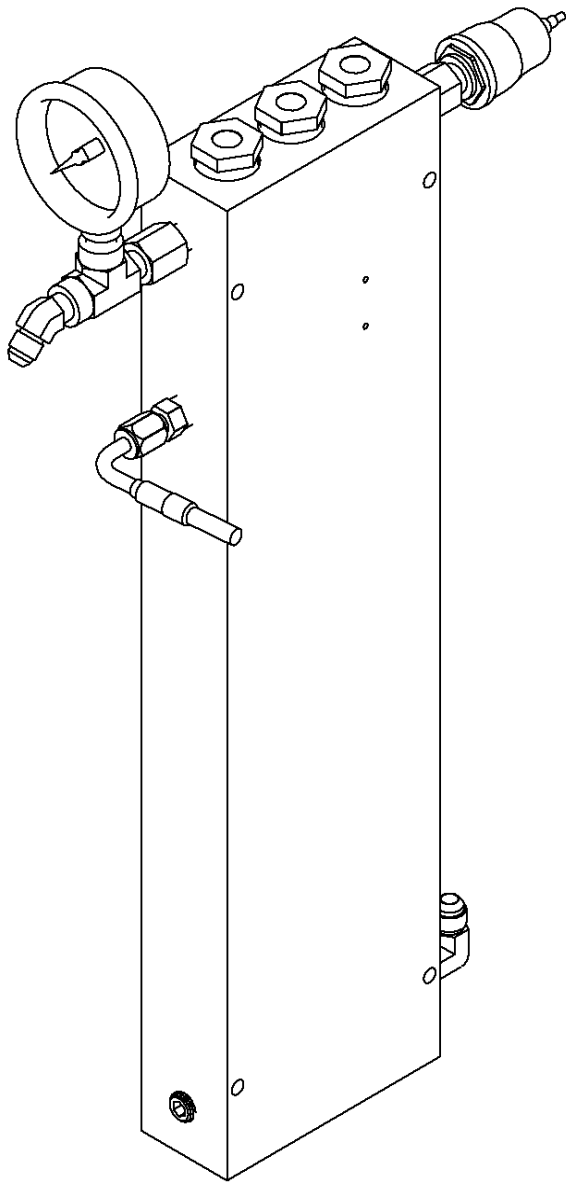

PH-17

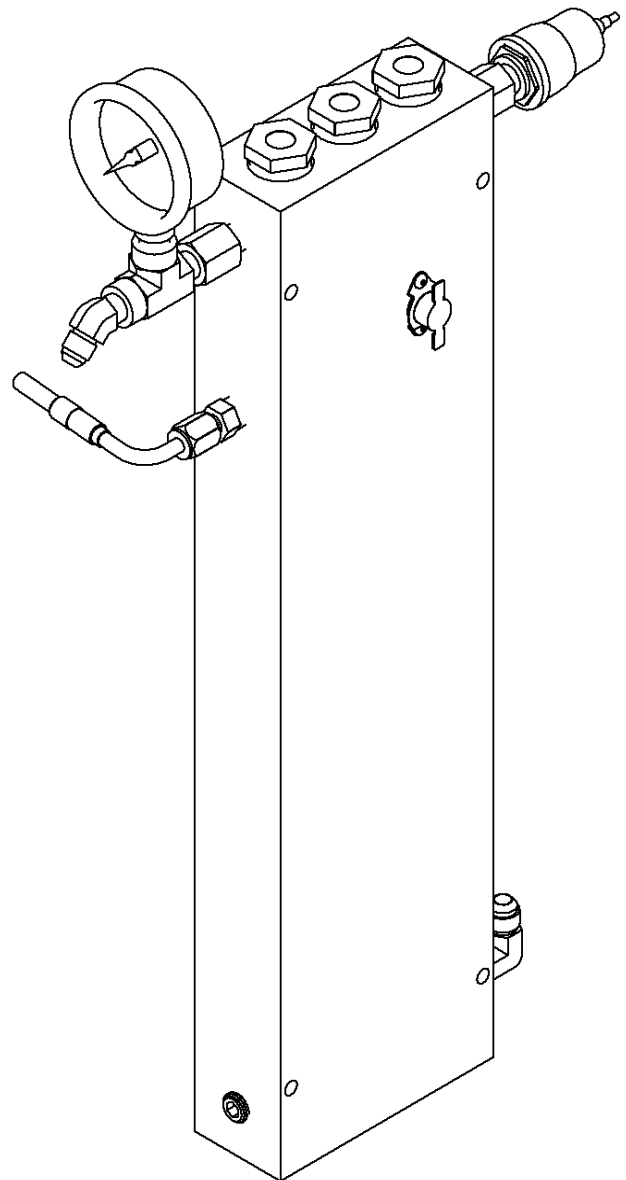

NOTE: PH-16 AND PH-17 ARE IDENTICAL EXCEPT FOR THE OUTLET FITTING, ORIENTATION OF THERMOCOUPLE, AND LOCATION OF THE OVERTEMP SWITCH



PA-25/PAX-25 Manual

Y STRAINER ASSEMBLY

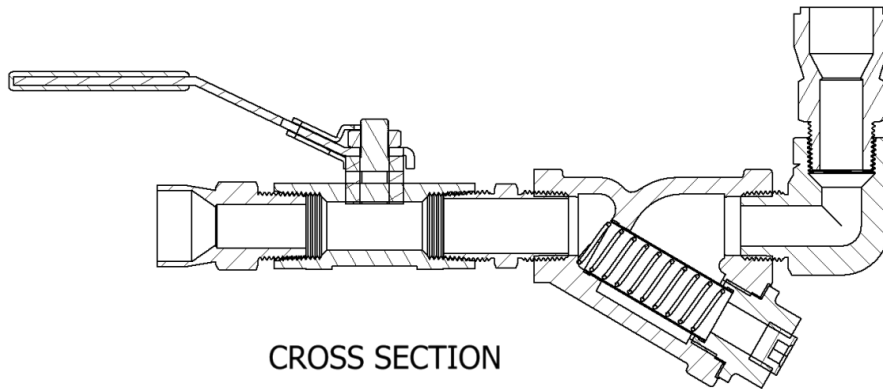
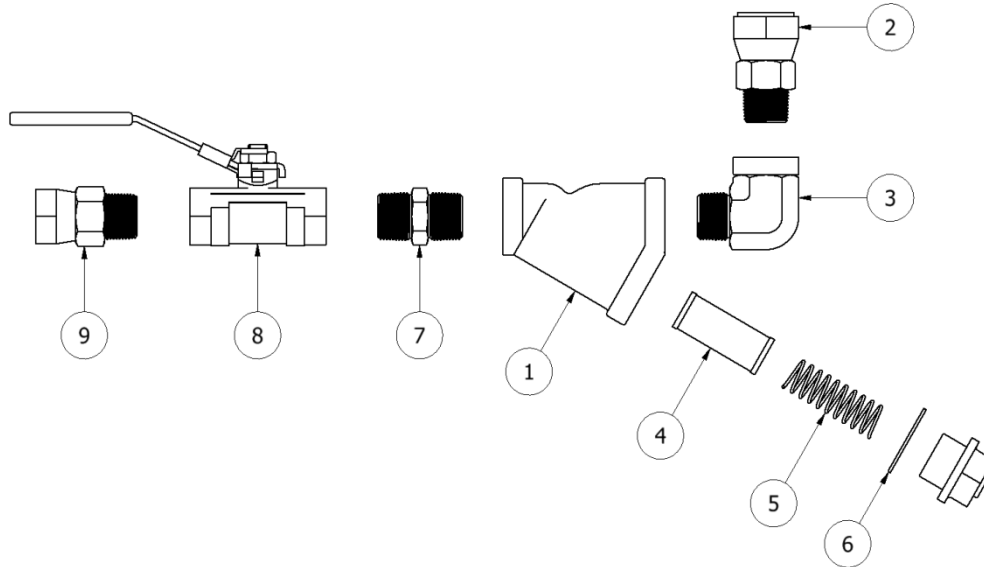

CROSS SECTION

| YS-4 ("A" SIDE) & YS-5 ("R" SIDE) | | | |
|-----------------------------------|-----|-----------------|-------------------------------------|
| ITEM | QTY | PART NUMBER | DESCRIPTION |
| 1 | 1 | RA-00074-00A | Y-STRAINER |
| 2 | 1 | HI-05092 | #16 JIC SWIVEL X 3/4 NPT |
| 3 | 1 | HI-05093 | ELBOW, 3/4 M X 3/4 F |
| 4 | 1 | RA-00074-03-30A | REPLACEMENT SCREEN (30 MESH) |
| | 1 | RA-00074-03-60A | REPLACEMENT SCREEN (60 MESH) |
| | 1 | RA-00074-03-80A | REPLACEMENT SCREEN (80 MESH) |
| 5 | 1 | SP-00009A | REPLACEMENT SPRING |
| 6 | 1 | RA-00074-02A | REPLACEMENT GASKET |
| 7 | 1 | HI-05017 | 3/4 HEX NIPPLE |
| 8 | 1 | RA-00078A | BALL VALVE 3/4" |
| 9 | 1 | HI-05016 | 3/4 X 3/4 SWIVEL FITTING ("R" SIDE) |
| | | HI-05018 | 3/4 X 1/2 SWIVEL FITTING ("A" SIDE) |



PA-25/PAX-25 Manual

AIR INLET ASSEMBLY

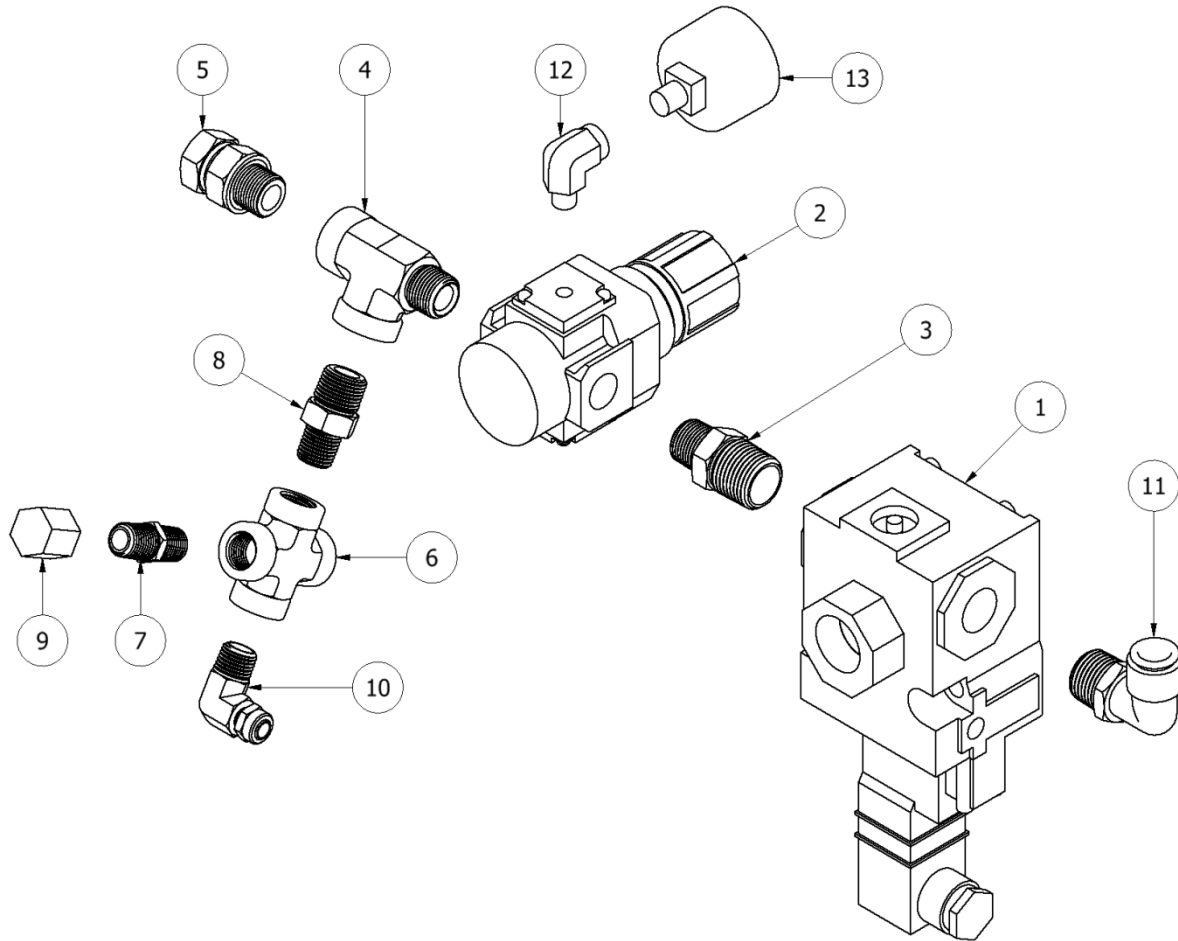

| AIR INLET ASSEMBLY | | | |
|--------------------|-----|--------------|-------------------------------|
| ITEM | QTY | PART NUMBER | DESCRIPTION |
| 1 | 1 | NE-00010A | SOLENOID VALVE; MAC |
| 2 | 1 | NE-06001 | AIR REGULATOR |
| 3 | 1 | HI-05087 | 1/2 X 3/8 NPT HEX NIPPLE |
| 4 | 1 | HI-05094 | 3/8 NPT RUNNING T |
| 5 | 1 | RA-06005 | 3/8 PIPE SWIVEL ADAPTER |
| 6 | 1 | HI-05109 | 1/4 NPT FEMALE CROSS |
| 7 | 1 | RM-PAR216P4 | 1/4 NPT HEX NIPPLE |
| 8 | 1 | RM-PAR216P64 | 1/4 X 3/8 NPT HEX NIPPLE |
| 9 | 1 | HI-05076 | 1/4 NPT CAP |
| 10 | 1 | AD-09 | 1/4 NPT X 1/4 TUBE FITTING 90 |
| 11 | 1 | NE-06012 | QUICK LOCK TUBE FITTING |
| 12 | 1 | HI-05080 | ELBOW 1/8 NPT MXF |
| 13 | 1 | NE-06007 | AIR PRESSURE GAUGE |



PA-25/PAX-25 Manual

HOSE TRANSFORMER ASSEMBLY

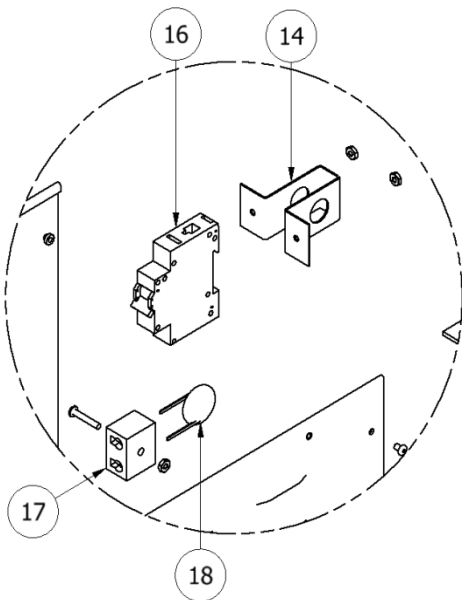
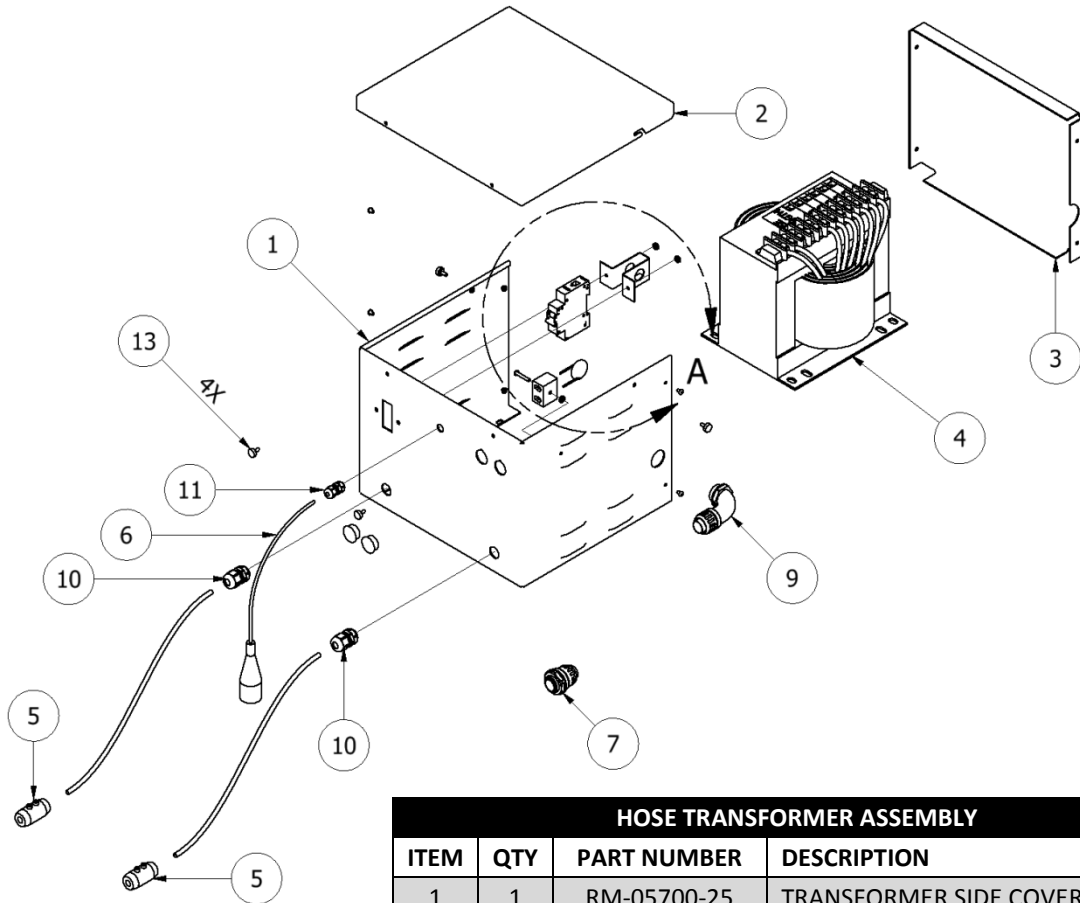

| HOSE TRANSFORMER ASSEMBLY | | | |
|---------------------------|-----|----------------|------------------------------|
| ITEM | QTY | PART NUMBER | DESCRIPTION |
| 1 | 1 | RM-05700-25 | TRANSFORMER SIDE COVER |
| 2 | 1 | RM-05700-26 | TRANSFORMER TOP COVER |
| 3 | 1 | RM-05700-27 | TRANSFORMER REAR COVER |
| 4 | 1 | EL-05225 | TRANSFORMER, 90 VOLTS |
| 5 | 2 | KT-00029A | HOSE CONNECTOR |
| 6 | 1 | EL-05235 | THERMOCOUPLE HARNESS |
| 7 | 1 | EL-05230-02 | CONDUIT CONNECTOR, STRAIGHT |
| 8 | 1 | EL-05230-01 | 3/4 FLEXIBLE CONDUIT |
| 9 | 1 | EL-05230-03 | CONDUIT CONNECTOR, 90 DEGREE |
| 10 | 2 | EL-000P12 | STRAIN RELIEF, LARGE |
| 11 | 1 | EL-000P7 | STRAIN RELIEF, SMALL |
| 13 | 4 | EL-05700-27 | TRANSFORMER KNOB ASSEMBLY |
| 14 | 1 | EL-00118A-00-1 | BREAKER MOUNT |
| 16 | 1 | EL-150 | BREAKER, 63 AMPS |
| 17 | 1 | EL-192 | TERMINAL BLOCK |
| 18 | 1 | EL-193 | INRUSH CURRENT LIMITER |



PA-25/PAX-25 Manual

TECHNICAL SERVICE BULLETIN

PRODUCT IMPROVEMENT NOTICE

June, 2013

REF: PMC AIR MACHINES

All PMC air driven machines manufactured after June 10th, 2013 have been fitted with an air manifold that will require only one air line to the machine. The manifold has provisions to supply air to the transfer pumps and the spray gun. The manifold will include a 3' air hose that will attach to the airline on the first section of heated hose coming off the machine. The manifold also includes a fitting to connect the air line harness for the transfer pumps.

The new air line harness is part number MA-00037A and is included with the transfer pump package GHO-A-PKG. The 3' air hose that will attach to the airline on the first section of heated hose is part number MA-00049A.



PA-25/PAX-25 Manual

PA, PAX, F-16, P-30 AIR MANIFOLD



NOTE:

- 1- MA-00049A is included with the machine.
- 2- MA-00037A is included in the GHO-A-PKG transfer pump package.



PA-25/PAX-25 Manual

PMCA AIR MANIFOLD

REMOVE SAFETY CAP AND CONNECT THE TRANSFER PUMP AIR LINE (MA-00037A)

INLET AIR 90-120 PSI

AIR HOSE TO HEATED HOSE (MA-00049A)

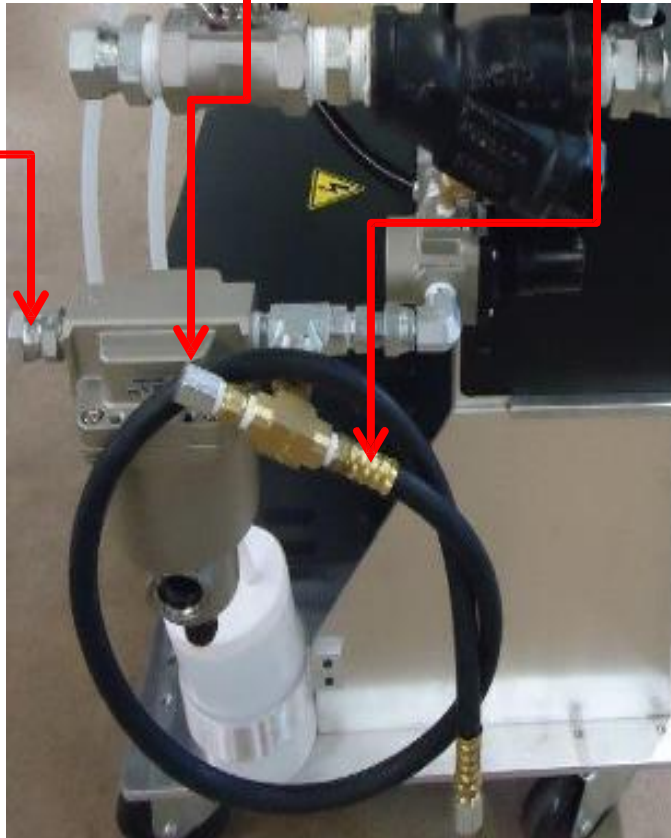

NOTE:

- 1- MA-00049A is included with the machine.
- 2- MA-00037A is included in the GHO-A-PKG transfer pump package.



PA-25/PAX-25 Manual

MANUAL REVISIONS

| REVISION | DATE | CHANGES | APPROVED |
|------------|-----------|----------------------------------|----------|
| 1.0 | 20-Feb-15 | Updated illustrations and tables | Vadams |